

**REGISTRATION PURSUANT TO
PART X of THE ENVIRONMENTAL PROTECTION ACT****Argyle Gold Project****Point Rouse Project****Baie Verte Area****Newfoundland****ANACONDA MINING INC.****Toronto, Ont.**

Contents

List of Appendices.....	3
List of Figures.....	4
List of Tables.....	4
1. Name of Undertaking	5
2. Proponent.....	5
2.1. Name of Corporate Body.....	5
2.2. Address.....	5
2.3. Chief Executive Officer	5
2.4. Principle Contact Person	5
3. The Undertaking	6
3.1. Nature of the undertaking.....	6
3.2. Purpose/Rationale/Need for the Undertaking	6
4. Description of the Undertaking	7
4.1. Geographic Location.....	7
4.2. Physical Features	12
4.2.1. Project Site Description	12
4.2.2. Existing Biophysical Environment.....	14
4.2.2.1 Site Ecology.....	14
4.2.2.2 Wildlife Species & Fish.....	14
4.3. Construction	15
4.3.1. Access Road Development	15
4.3.2. Site Development	17
4.3.3. Potential Sources of Pollution during Construction	17
4.3.3.1 Water.....	17
4.3.3.2 Noise and Vibrations	22
4.3.3.3 Air Emissions.....	24
4.3.3.4 Dust	25
4.3.3.5 Fuel and Lubricants.....	26
4.3.3.6 Sewage	26
4.3.3.7 Waste and Garbage	26
4.3.3.8 Potential Resource Conflicts.....	27
4.4. Operation	27
4.4.1.1 Proposed Mining.....	27
4.4.1.2 Trucking of Ore	34
4.4.1.3 Milling of Ore.....	36
4.4.2. Potential Sources of Pollution during Operation.....	39
4.4.2.1 Water.....	39
4.4.2.2 Noise and Vibrations	40
4.4.2.3 Air Emissions	40
4.4.2.4 Dust	41
4.4.2.5 Fuel and Lubricants.....	42
4.4.2.6 Sewage	42
4.4.2.7 Waste and Garbage	42

4.4.3	Potential Resource Conflicts.....	42
4.4.4	Reclamation.....	42
4.4.4.1	Rehabilitation Plan	42
4.4.4.2	Water Testing	43
4.4.4.3	Potential Acid Rock Drainage (ARD) Testing.....	44
4.4.4.4	Open Pit Closure and Reclamation	46
4.4.5	Project Operation Considered	49
4.5	Occupations.....	49
4.6	Project Related Documents	50
5	Approval of the Undertaking	51
6	Schedule	52
7	Funding.....	54
8	Submission.....	55

List of Appendices

Appendix A – Environmental Baseline Studies
 Appendix B – Acid Rock Drainage Testing
 Appendix C – Consultation with the Town of Ming’s Bight
 Appendix D – Argyle Women’s Employment Plan
 Appendix E – Emergency Response Plan
 Appendix F – Contingency Plan
 Appendix G – Waste Management Plans
 Appendix H – Environmental Protection Plan (EPP)
 Appendix I – Cross Sections of Final Waste Stockpile
 Appendix J – RPC Metallurgical Testing Results
 Appendix K – Pine Cove ARD Results
 Appendix L – Argyle Regional Features
 Appendix M – Argyle Relative to Stog’er Tight

List of Figures

Figure 1 - Satellite Image of the Argyle Property in Relation to Ming's Bight and Pine Cove	7
Figure 2 - Mineral Licences for The Project (Point Rouse Project)	9
Figure 3 - Localized Watershed and Drainage Map at The Project	10
Figure 4 - Historical Weather and Climate Data for Baie Verte Peninsula (La Scie Weather Station)	11
Figure 5 - Proposed Site Layout for The Project	13
Figure 6 - Map Showing the Location of the Proposed Access Road from Stog'er Tight to The Project	16
Figure 7 - Cross Section of Typical Proposed Drainage Ditch	19
Figure 8 - Options for Discharging Water into the Environment	21
Figure 9 - 500 m Blast radius for Blasting Activities at The Project	31
Figure 10 - Potential Relocation of the Town of Ming's Bight Water Supply Intake	33
Figure 11 - Haulage outline from The Project to Pine Cove Mill	35
Figure 11 - Mill Recovery Flow Sheet	37
Figure 12 - Process Flow Diagram for Pine Cove Mill	38
Figure 13 - Metallurgical Balance for the Pine Cove Mill	39
Figure 14 - Argyle Open Pit Closure Measures	48

List of Tables

Table 1 - Proximity of The Project in Relation to Geographical and Environmental Features	8
Table 2 - Table of Mineral Licences for The Project	9
Table 3 - FDP Requirement for Discharging Water into the Environment	18
Table 4 - Typical Construction and Operational Equipment/Activity Noise Levels	23
Table 5 - Anticipated Fuel Consumption by Equipment Type at The Project	25
Table 6 - Anticipated GHG Emissions for The Project	25
Table 7 - Design Parameters for Preliminary East Pit Design	28
Table 8 - Design Parameters for Preliminary West Pit Design	28
Table 9 - Summary of Waste Stockpile Design Parameters	29
Table 10 – The Project Acid Rock Drainage Test Results	45
Table 11 - Grade Values and Waste/Ore Designation for The Project ARD Samples	45
Table 12 - List of Direct Occupations and Quantity for the Construction and Operation Phases	49
Table 13 - Summary of Regulatory Body Consultations Regarding The Project	50
Table 14 - Projected permits, Authorizations and Approvals for The Project	51
Table 15 - Project Schedule	53

1. Name of Undertaking

Argyle Gold Project

2. Proponent

2.1. Name of Corporate Body

Anaconda Mining Inc.

2.2. Address

P.O.Box 238
Baie Verte, NL
A0K1B0

2.3. Chief Executive Officer

Dustin Angelo
150 York Street
Suite 410
Toronto, Ontario
M5H 3S5
Canada
(416) 604-6622

2.4. Principle Contact Person

Jordan Cramm
Mine & Engineering Superintendent
P.O Box 238
Baie Verte, NL
A0K 1B0
709-800-7332 x. 2111

3. The Undertaking

3.1. Nature of the undertaking

Anaconda Mining Inc. (Anaconda) has ownership of the Argyle Gold Project (The Project). The Project contains the Argyle deposit, which hosts an indicated resource of 543,000 tonnes (t) with an average grade of 2.19 grams per tonne (g/t). In addition to the indicated resource, there is an inferred resource of 517,000 tonnes with an average grade of 1.82 g/t. These values assume a cut-off grade of 0.5 g/t Au. Anaconda intends to develop The Project by means of open pit mining over a two-year period commencing in June 2019. Milling of the Argyle ore is planned to be at Anaconda's Pine Cove Mill on the Ming's Bight Peninsula. Transportation of this ore will be via a network of access roads connecting The Project to the Pine Cove Access road, which leads to the Pine Cove Mill. The haulage route is approximately 6.5 kilometers (km) long.

3.2. Purpose/Rationale/Need for the Undertaking

Prior to 2012, there is no recorded historical exploration related to The Project. A soil survey completed in 2012 by Anaconda represents the first exploration activities in this area. The survey consisted of 228 soil samples and 25 rock samples, collected on 100 metres (m) spaced lines with sample stations every 25 m. 25 samples of altered/mineralized outcrops were also collected. The samples revealed anomalous gold-in-soil values in the previously unexplored area. Highlights of the soil survey include eight soil samples that assayed greater than 100 ppb (parts per billion) Au, to a maximum of 4880 ppb Au, and float assays of 2180, 9080, and 4880 ppb Au in angular rusty quartz material.

Trenching by Anaconda in 2014 identified gold mineralization associated with quartz veined, pyritized, and strongly altered gabbro. Approximately 750 m of trenching was completed. Channel sampling revealed the presence of gold mineralization associated with the altered gabbro. Four Channel samples were completed in 2015.

An exploration program completed in 2016 by Anaconda was designed to better understand the geology, alteration, and mineralization of the Argyle prospect. The work consisted of diamond drilling, line cutting, ground IP and magnetics, geological mapping, and prospecting. The exploration targeted shallow areas of mineralization outlined in previous trenching, as well as down-dip and along strike of the known areas of mineralization. Approximately 3770m of drilling was completed over 44 holes. Through drilling and trenching, a zone of hydrothermal alteration and gold mineralization was delineated with a strike length of 600 m and down dip 225 m.

Gold mineralization at The Project is hosted within a 40 m to 50 m thick, gently north dipping east-west striking gabbro sill. The magnetic gabbro contains discrete zones of magnetite destruction associated with zones of hydrothermal alteration and gold mineralization. Gold is intimately associated with pyrite; generally residing on pyrite grain margins and along fractures within pyrite. Fine gold (< 5µm) occurs as inclusions within pyrite. Overall the alteration zone is between 5 to 40 m thick. Gold mineralization is associated with 1-5% pyrite. The zone of mineralization defined by exploration in 2016 has a current strike length of 600 metres and has been defined down-dip for 225 metres.

In 2017, 25 percussion drill holes were completed totalling 491 m to test the near surface mineralogy of The Project. The drilling was conducted with the intention of delineating the geometry and grade of the near surface portion of the deposit, and to provide support for a compliant resource estimate. On January 8, 2018, a Mineral Resource Estimate was announced in accordance with NI 43-101 requirements.

Anaconda's Pine Cove mining operations at the main pit have been completed in March 2018, at which time mining operations began at Stog'er Tight. Stog'er Tight, and two small extensions at Pine Cove Pit operation, will finish in June 2019, at which time the Pine Cove Mill will require additional resources to operate at its existing

throughput. Anaconda intends on developing The Project, completing mining activities and processing the material at the Pine Cove Mill to maintain its current throughput.

4. Description of the Undertaking

4.1. Geographic Location

Argyle, part of Anaconda’s Pointe Rousse Project, is located approximately 500 m southwest of Ming’s Bight, on the Baie Verte Peninsula. Ming’s Bight is about 26 road kilometres from the town of Baie Verte. The Project can be accessed via a forest access road approximately two kilometers southwest of Ming’s Bight, leading from Provincial Route 418. The Baie Verte/Ming’s Bight area is serviced by the Deer Lake Airport, located approximately 160 kilometers southwest of Baie Verte. The Baie Verte Peninsula is sparsely populated with small towns, the largest of which is the town of Baie Verte, located approximately 26 km from Argyle (by road), with an approximate population of 1400 residents. Predominant industries are small logging and saw mill operations, and mining (including Anaconda’s Pine Cove Gold Mine and Rambler Metals and Mining’s Ming Copper Mine), with other small commercial and local businesses. The nearest commercial/industrial centers are the Town of Grand Falls-Windsor (200 km) and the City of Corner Brook (230 km).

The location of The Project is shown in Figure 1. See Appendix L and M for additional drawings outlining the location of The Project relative to the Baie Verte Peninsula.

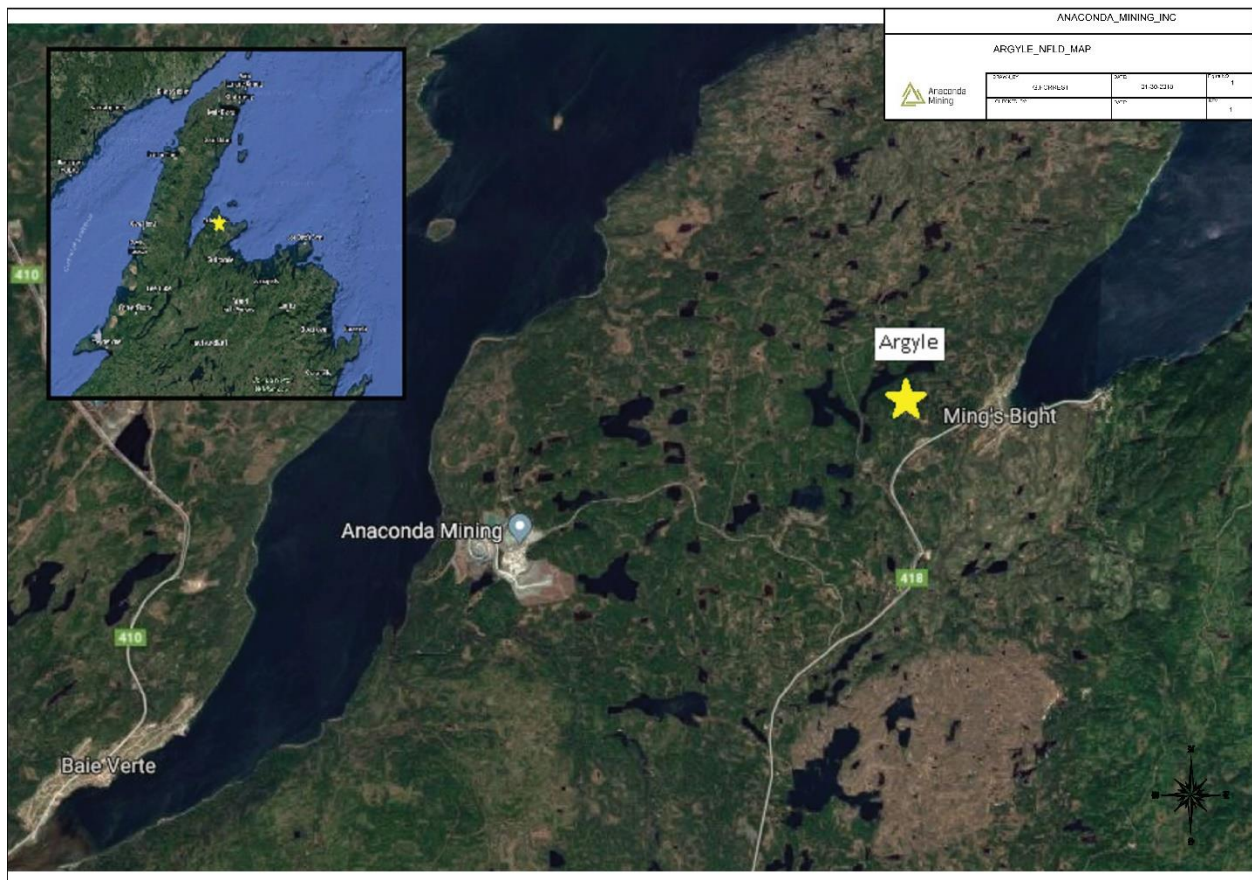

Figure 1 - Satellite Image of the Argyle Property in Relation to Ming's Bight and Pine Cove

The existing and available information does not indicate that Aboriginal Peoples currently undertake traditional land and resource use activities within or near Argyle. Anaconda is not aware of any traditional Aboriginal fishing or hunting occurring near The Project, as well.

The Qalipu First Nation has no reserve land; it is made up of 66 traditional Mi'kmaq communities, spread out over nine Electoral Wards. The closest Qalipu community to Argyle is Sop's Arm, located approximately 85 kilometers (km) southwest in White Bay, NL. The Miawpukek Band Reserve is located in Conne River (south coast of Newfoundland), 230 km from The Project. Approximately 860 people live on the 36 km² reserve. The Miawpukek Band does not currently have established traditional rights outside of the reserve boundaries and Anaconda is not aware of any Aboriginal fishing or hunting occurring near The Project.

The proximity of The Project in relation to various geographical and environmental features is listed in Table 1. Distances are measured from the center of the Argyle East Pit (straight line distance).

Table 1 - Proximity of The Project in Relation to Geographical and Environmental Features

Feature Type	Name/Description	Distance from Argyle
Residence	Town of Ming's Bight Resident	480 m
Campground	Flatwater Pond	30 km
Power Line	Utility Power Line	500 m
Provincial Park	Main River Waterway Provincial Park	85 km
Important Bird Area	Bell Island South Coast	85 km
Migratory Bird Sanctuary	Shepherd Island	90 km
National Park	Gros Morne National Park	130 km
Marine Protected Area	Wadham Islands	170 km
Aboriginal Community	Qalipu Mi'kmaq First Nation*	85 km
Federal Reserve Land	Samia Jij Miawpukek Reserve	230 km
Province	Quebec	200 km
Provincial Wilderness Reserve	Middle Ridge Wilderness Reserve	190 km
Country	United States of America	1000 km

Note: Qalipu First Nation is comprised of communities and wards across Newfoundland. The closest community to The Project is Sop's Arm in White Bay, NL.

The Project is located adjacent to the Town of Ming's Bight Water Supply. The water supply consists of three large ponds, which lead to an intake to supply Ming's Bight with clean, safe drinking water. Adjustments to the boundary of the water supply have been proposed by Water Resources to the Town of Ming's Bight. Anaconda has adjusted several features of The Project to remain outside the existing water supply boundary, as well as the proposed changes. Once the final water supply boundary is determined by Water Resources, the required adjustments will be made to ensure that The Project will not impact the water supply. Anaconda has maintained communication with the Town regarding the proposed changes and is committed to ultimately ensuring the availability of clean, safe water for the Town of Ming's Bight.

The Project is included under Map Staked License No's. 012433M (the Tenacity option; 11 claims) and 020060M (the Froude option; 11 claims). The options are shown in Figure 2 and Table 2. The claims are located on NTS map 12H/16 at UTM coordinates 5,537,000N & 568,000E (NAD 1927, Zone 21).

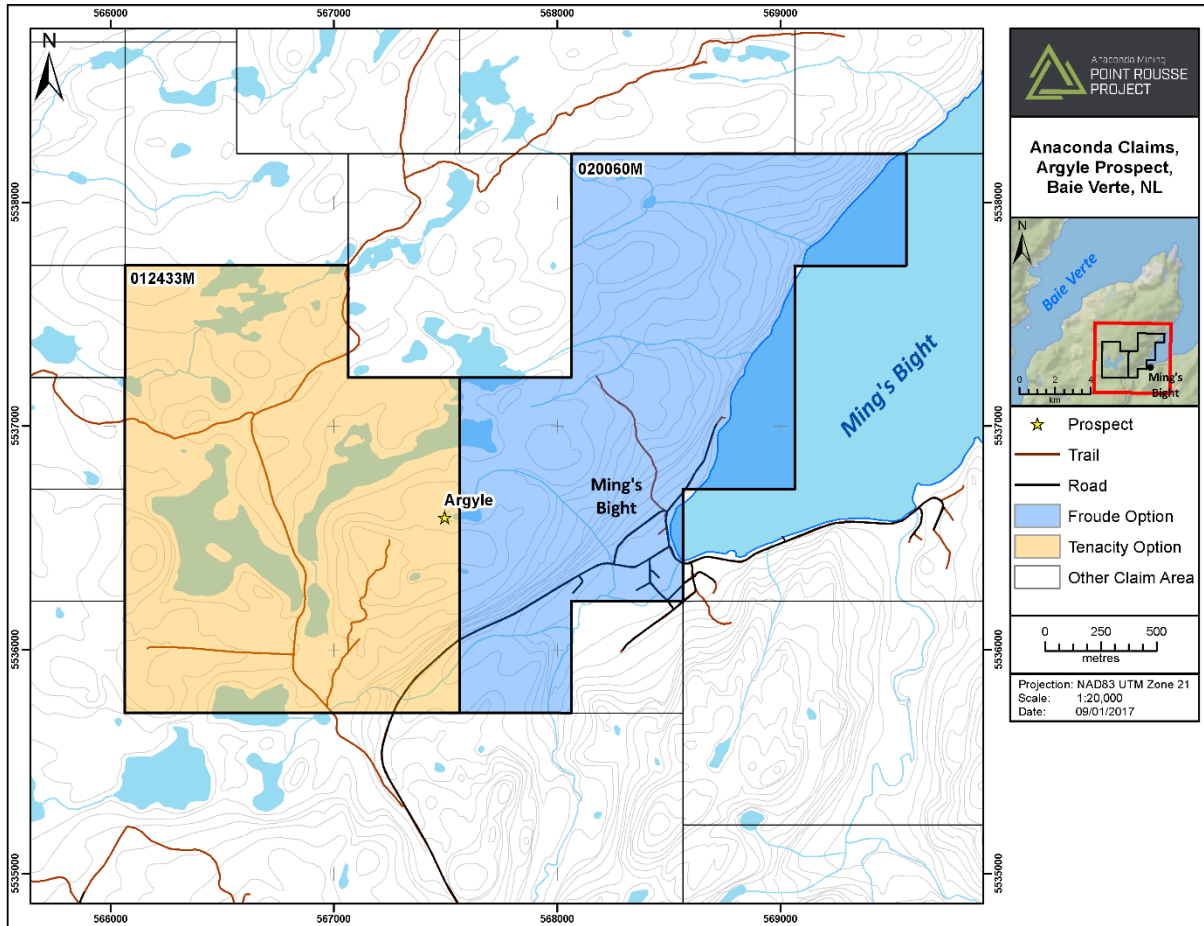

Figure 2 - Mineral Licences for The Project (Point Rouse Project)

Table 2 - Table of Mineral Licences for The Project

License	Holder	No. of Claims	Date Issued	Anniversary Date
012433M	Tenacity Gold Mining Company Ltd.	11	2006/08/24	2021/08/24
020060M	Herb M. Froude	11	2012/04/18	2017/04/18

The Project is located within a small, locally restricted watershed containing several small ponds and streams. The area is relatively high in elevation compared to its surroundings. The proposed ditching network, discussed in Section 4.3.3.1, will prevent surface water from leaving The Project site, and direct it into a series of settlement ponds that are blasted into the ground. A final settlement pond will discharge water, once it meets required criteria, into a natural channel that drains to the East of the Town of Ming's Bight water supply. The localized watershed drainage map, with regards to the site area, and perimeter ditching network is displayed in Figure 3. The blue arrows represent the drainage paths at various locations around the site.

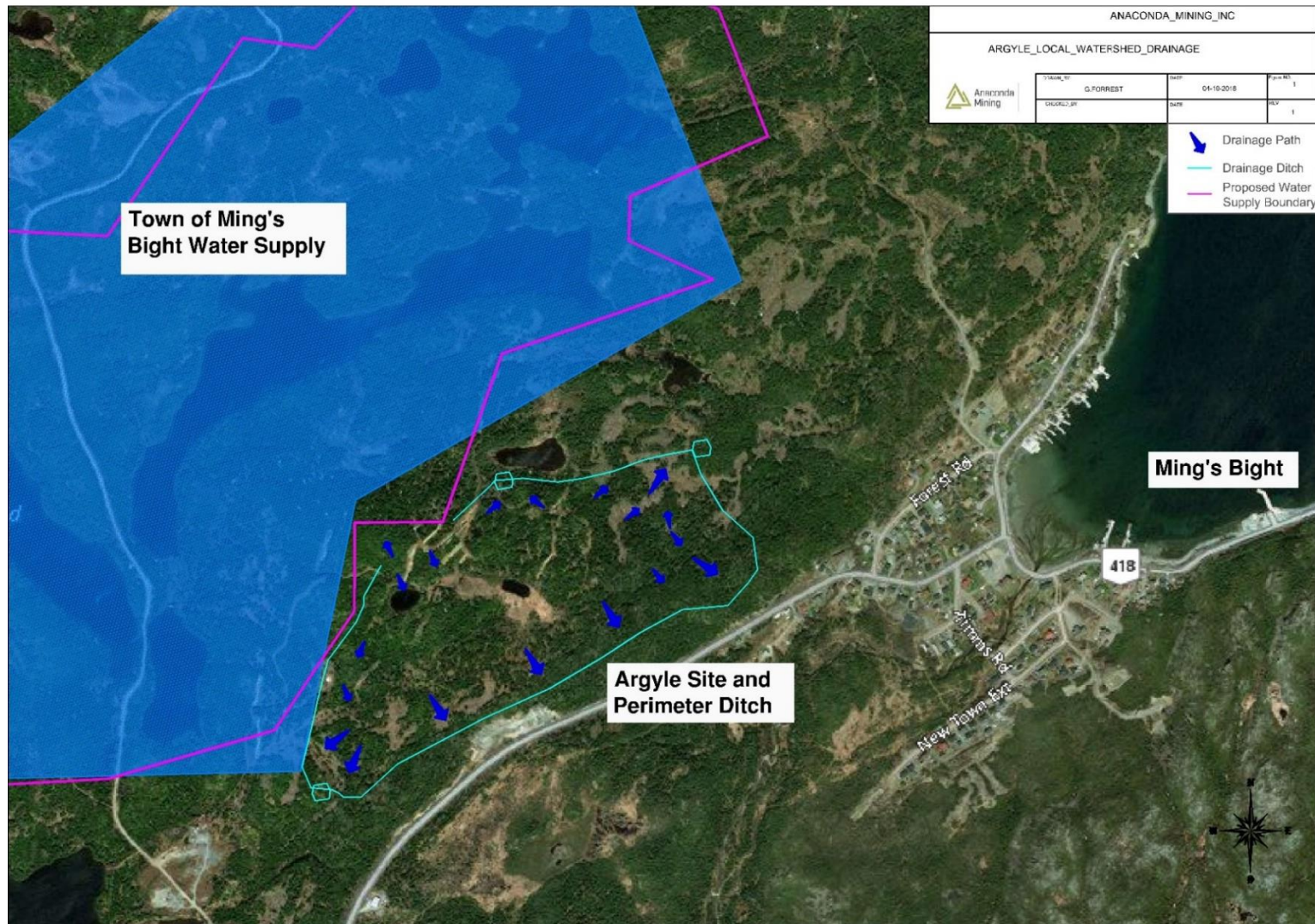

Figure 3 - Localized Watershed and Drainage Map at The Project

Larger fir and spruce tress cover most of The Project property with outcrop making up <3%. Some of the area has been logged by local residents of the region. Glacial till overburden is generally thin, ranging from 0.1 m to less than five metres thick.

The terrain surrounding the Point Rousse Project site is generally rolling, with gradients over portions of the site ranging up to 22 percent. A steep embankment runs along the eastern edge of the area, with Provincial Route 418 located at the toe of the slope. The surrounding terrain is typical of the Newfoundland upland areas, with relatively dense vegetation and tree cover, interspersed with small ponds and bogs. The bedrock in the area is overlain with a thin layer (0.1 m - 5 m) of unconsolidated material being comprised of peat, loose brown sand and gravel.

At Argyle, moderate to steep slopes rise to a maximum elevation of 165 m, averaging 130 to 150 m above sea level. Ponds and small lakes are present, although sparse. Vegetation consists of mature spruce and fir, largely cutover, with re-growth of alder, birch and young fir. Alders are prevalent in older stripped and wet areas.

The climate of the Baie Verte Peninsula can be described as a northern temperate climate zone. Winter conditions are present from November through late March. This includes sub-zero temperatures and heavy snowfalls. Summer conditions are present from late June through early September. Spring and fall conditions experience both cool temperatures and frequent periods of rain. The average monthly temperatures and precipitation for the area ranging from 1984-2006 can be seen in Figure 4. This data has been collected from the La Scie weather station (Environment Canada, 2018)

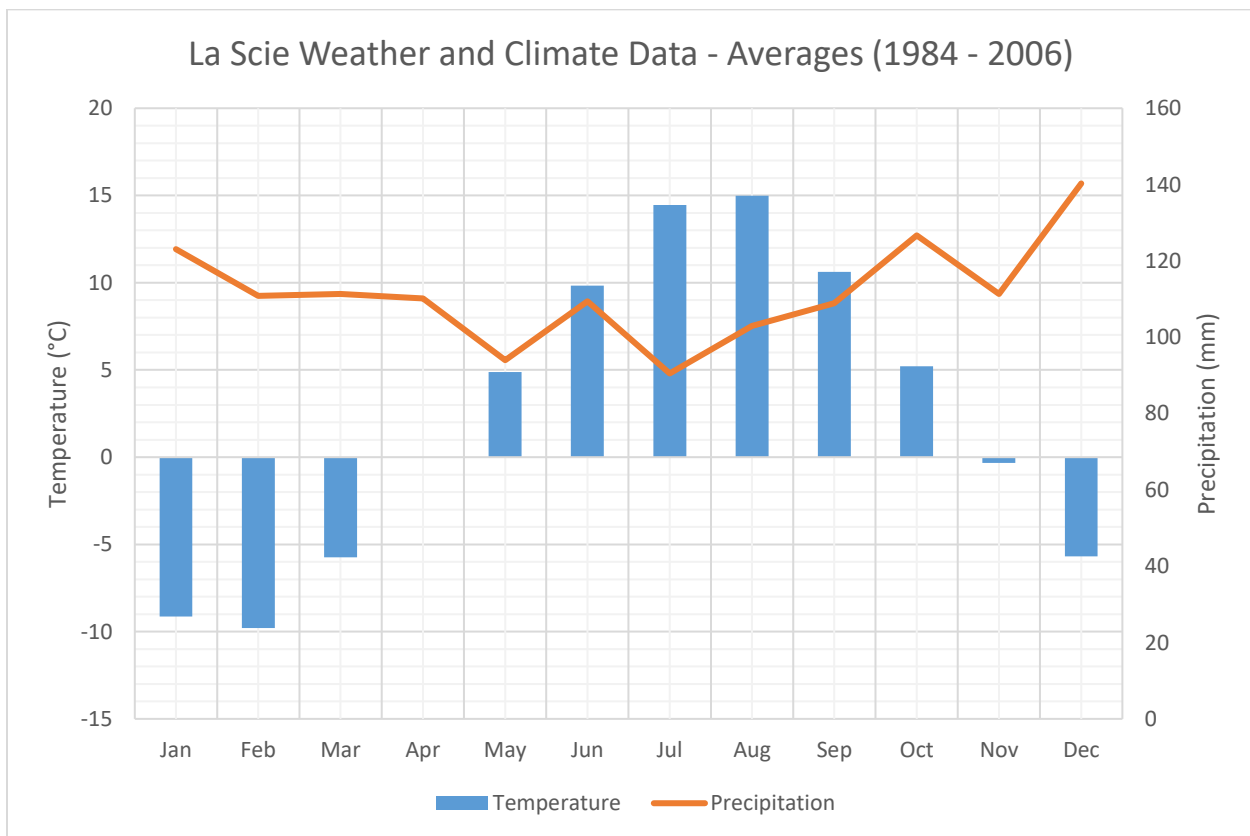

Figure 4 - Historical Weather and Climate Data for Baie Verte Peninsula (La Scie Weather Station)

It is Anaconda’s understanding that The Project does not require access to, use or occupation of, or the exploration, development, and production of lands and resources currently used for traditional purposes by Aboriginal Peoples.

4.2. Physical Features

4.2.1. Project Site Description

The primary features of The Project will include the open pit mine and stockpile areas for waste rock, ore material, and organics. Other facilities will consist of a temporary office trailer and storage sea-can. All other required facilities are existing and located at the Stog'er Tight and Pine Cove operations, which are also part of the Point Rouse Project. Road access to the site will be by a forest access road off Provincial Route 418, as described in Section 4.1. An upgraded exploration trail (Figure 6) will connect the same forest access road with Stog'er Tight. It is this access (Stog'er Tight to the forest access road) that will be used for transporting ore from The Project to the Pine Cove Mill. It is anticipated approximately 20,000 t of waste rock will be needed for the road access. Waste rock will come from a surface blast at The Project, and work from Argyle towards Stog'er Tight. Figure 5 below shows the layout of the proposed site.

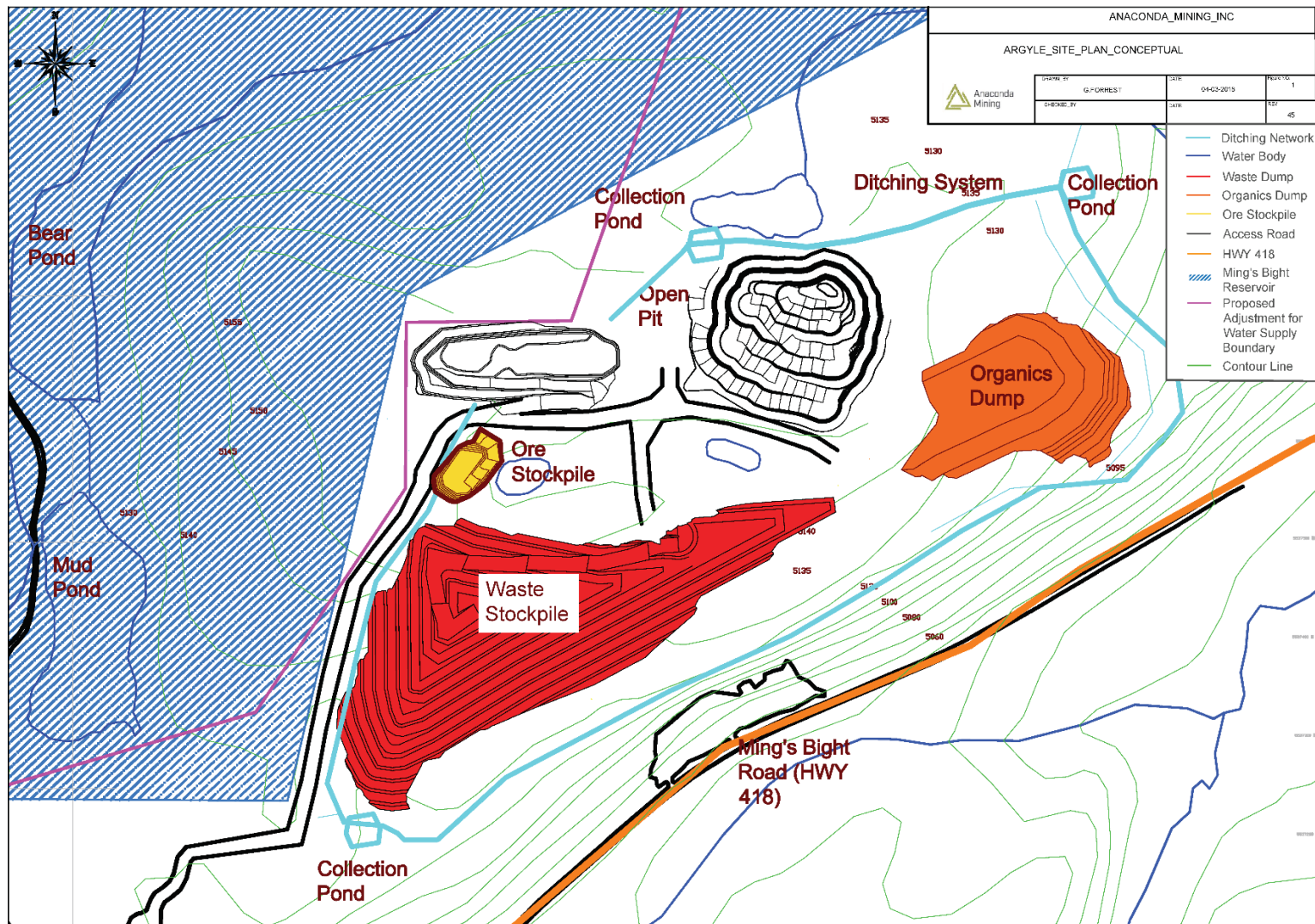

Figure 5 - Proposed Site Layout for The Project

4.2.2. Existing Biophysical Environment

4.2.2.1 Site Ecology

The Project falls within the Northshore Ecoregion of Newfoundland which characterizes as mostly forest-covered with some barren areas (particularly in coastal localities). In general, black spruce and balsam fir forests are the most prevalent, which form a continuous forest cover except where barrens dominate on the coastal areas. The quality and height of forests in this ecoregion tends to deteriorate towards the coast and with increased wind exposure.

There are several wetlands in the area. However, they are all ground-water fed and are unlikely to support fish habitat, as stated by GEMTEC in the Aquatic Habitat Assessment. Refer to the Wetland and Aquatic Habitat Assessment completed by GEMTEC in Appendix A for a detailed description and mapping of the wetland areas encountered.

The Common Wintergreen, an S2 plant species as per the Atlantic Canada Conservation Data Centre, was the only rare plant species identified during field studies. Approximately 5650 Common Wintergreen plants were identified within 100 different patches around The Project. As well, a control area was established approximately 900m from The Project that was considered to have a suitable habitat. In this control area, approximately 200 individual plants were identified in several patches. Due to the number of plants identified within the Argyle area and outside, the Common Wintergreen is assumed to be regionally abundant. Refer to the Vegetation and Plant Survey conducted by GEMTEC in Appendix A for a detailed ecoregion description of The Property.

4.2.2.2 Wildlife Species & Fish

Big game, furbearers, and a wide range of birds occur in the area and have generally adapted to human activities in the Point Rousse Project area. The principle large mammal species in the area is moose (*Alces alces*), which is found within Moose Management Area 14 – Baie Verte. Moose densities are reported to be low and harvesting of moose has, at times, been reported to be quite heavy.

Caribou (*Rangifer tarandus*) are not hunted at present on the Baie Verte Peninsula. The nearest concentration of this species, the Hampden, the Humber, and the Gaff Topsails herds, occur well to the south of this region. Black bears are known to occur in the region. Other mammals such as furbearers and small mammals occur, but there is generally little information available on these species. Beaver (*Castor Canadensis*) are common in the ponds and streams in the area, although none have been observed at Argyle and there is little evidence to support their presence.

A total of 20 bird species, including 89 individual records, were documented in a Breeding Bird survey conducted by Gemtec. These species are characteristic of the forest and wetland habitats found within The Project area. No species at risk were recording during the surveys. The detailed results of the Breeding Bird Survey can be found in Appendix A. The abundance of high profile raptor species such as Bald Eagle (*Haliaeetus leucocephalus*) and Osprey (*Pandion haliaetus*) is low in the area with insufficient cliff-nesting habitat available; the local forest is unsuitable for nest sites.

As outlined in the Environmental Baseline Studies report completed by Gemtec, there is little or no viable fish habitat in the Mine Development Area (MDA), therefore the potential for fish to be present is very low.

4.3. Construction

The construction phase of the site development is broken up into the following areas:

- Access road development;
- Site development

4.3.1. Access Road Development

Access to the site will utilize an upgraded exploration road connecting Stog'er Tight to the forest access road that connects to HWY 418. This additional road upgrade will be used for equipment and ore transportation for Argyle, as well as employee access from other Point Rouse sites. Construction of this upgrade is expected to take approximately four weeks. Typical construction equipment will consist of excavators, loaders, dozers and rock trucks. The additional access road can be seen in Figure 6. The brown line between Argyle and Stog'er Tight represents the section of the access road that requires construction.

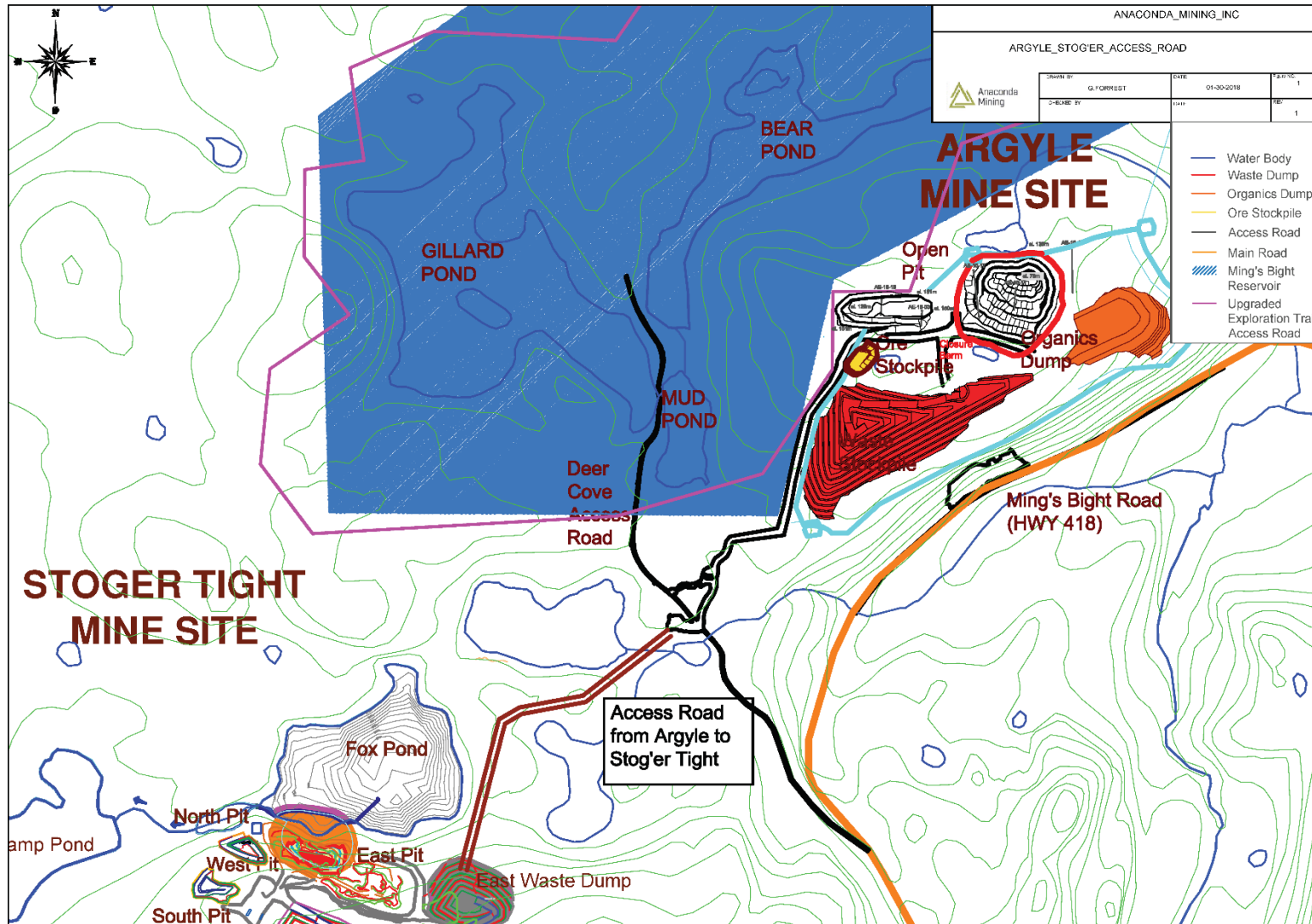

Figure 6 - Map Showing the Location of the Proposed Access Road from Stog'er Tight to The Project

4.3.2. Site Development

The current proposed Project site area is approximately 500 m wide by 750 m long for a total area of approximately 37.5 hectares (ha). Site preparation will be limited to a minimal amount of cutting, grubbing and leveling, primarily within the boundaries of the open pit and stockpiles. This is anticipated to be an area of approximately 20 hectares. The timber in this area consists of mature spruce and fir, largely cutover, with re-growth of alder, birch and young fir. Any mature timbers that are encountered and are salvageable will be salvaged by the contractor whilst cutting is taking place. Waste rock from the mine operation will be suitable for leveling, based on previous mining and blasting experience in the area and use of rock for other site development at Pine Cove and Stog'er Tight. The site development is anticipated to take approximately six weeks. Upon the completion of site preparation/development, a temporary office trailer and storage sea-can will be brought to the site.

A power supply will be established for The Project. An existing single-phase power line (currently not in service) is in place along the forest road that is used to access the Argyle property. This line will be upgraded to supply three-phase power for submersible pumps and the office trailer. Submersible pumps will be required for general de-watering and water management.

A ditching system will be developed around The Project site to collect surface water that is draining away from the area. This ditching system will lead to a series of collection and settlement ponds, where it can be tested before being released to the environment. This is further discussed in Section 4.3.3.1. Any release of water from the site will be in compliance with Mining Metals Effluent Regulations (MMER) guidelines. The water being discharged from The Project will be towards the northeast of the site and will not enter the Town of Ming's Bight's water supply. Refer to Section 4.3.3.1 for a detailed explanation on water management at The Project.

Site Development is anticipated to begin in early 2019.

4.3.3 Potential Sources of Pollution during Construction

Potential Sources of pollution during the construction stage are outlined in the following sections. Additionally, Anaconda has developed the internal documents *Environmental Protection Plan* and *Emergency Response Plan*. These plans have been generally developed based on the Pine Cove Site, as that has been the only active operational site for Anaconda. These documents will be updated to address any specific construction components involving The Project.

4.3.3.1 Water

During construction and site development at The Project, dust and fine material may have the potential to mobilize into ponds and streams near the road. To mitigate this, sediment-trapping material such as approved filtration fabrics will be used in areas subject to siltation and erosion. Water trucks will be used for dust suppression on the roads and stockpiles. Water for dust suppression on haul roads has proven to be sufficient at other Point Rouse operations.

All mechanical equipment will be inspected regularly to ensure leakage of fuel, hydraulics, oils or other hazardous products does not occur. Spill kits will be on site and available in the case of an emergency.

As required, standard mitigation methods, such as on-site drainage ditch channels, collection sumps and settlement ponds, will be used to control silt and sediment and prevent the release of potential contaminants from The Project site. A 1.0 m deep drainage ditch and collection system is planned for the site that will channel water into a series of settlement ponds around site. The collection and settlement ponds will be in-ground facilities (blasted into ground) and will not contain any dam works. It is expected that the settlement ponds will have a capacity ranging from 5000 m³ – 15000 m³. Detailed design of the collection and settlement ponds will be developed for the submission of the Development Plan. The channels will be graded and lined with drainage stone/rip rap material to prevent erosion and will prevent surface water leaving The Project site. Table 3 shows the MMER Final Discharge Point (FDP) requirements for various parameters that are tested in water quality samples. Testing will be conducted until these criteria are met, at which time water may be released into the environment at the approved discharge point (these tests are completed by a third party). Treatment options will be evaluated, if required, depending on the parameters that are not meeting the standards.

Table 3 - FDP Requirement for Discharging Water into the Environment

Parameter	Maximum Authorized Monthly Mean Concentration	Maximum Authorized Concentration in a Composite Sample	Maximum Authorized Concentration in a Grab Sample
Arsenic	0.50 mg/L	0.75 mg/L	1.00 mg/L
Copper	0.30 mg/L	0.45 mg/L	0.60 mg/L
Cyanide	1.00 mg/L	1.50 mg/L	2.00 mg/L
Lead	0.20 mg/L	0.30 mg/L	0.40 mg/L
Nickel	0.50 mg/L	0.75 mg/L	1.00 mg/L
Zinc	0.50 mg/L	0.75 mg/L	1.00 mg/L
TSS	15.00 mg/L	22.50 mg/L	30.00 mg/L
Radium 226	0.37 Bq/L	0.74 Bq/L	1.11 Bq/L
pH	Allowable Range 5.5 – 9.0 units		
ALT	Toxic pass		

See Figure 5 and Figure 7 for the proposed location and cross section of the ditching system at The Project. The ditch will be 1 m deep, sloped at 1.5:1, and lined with rock to prevent erosion of the bedding material. The ditch will be dug into competent till prior to lining and graded to drain towards the nearest collection pond. Small submersible pumps will pump the water from the collection ponds to a main collection pond, at which point the water will be tested. Water testing will take place regularly to ensure discharged water is of, at a minimum, sufficient quality. The ditch will run along the perimeter of the site to prevent any surface water from leaving the site uncontrollably.

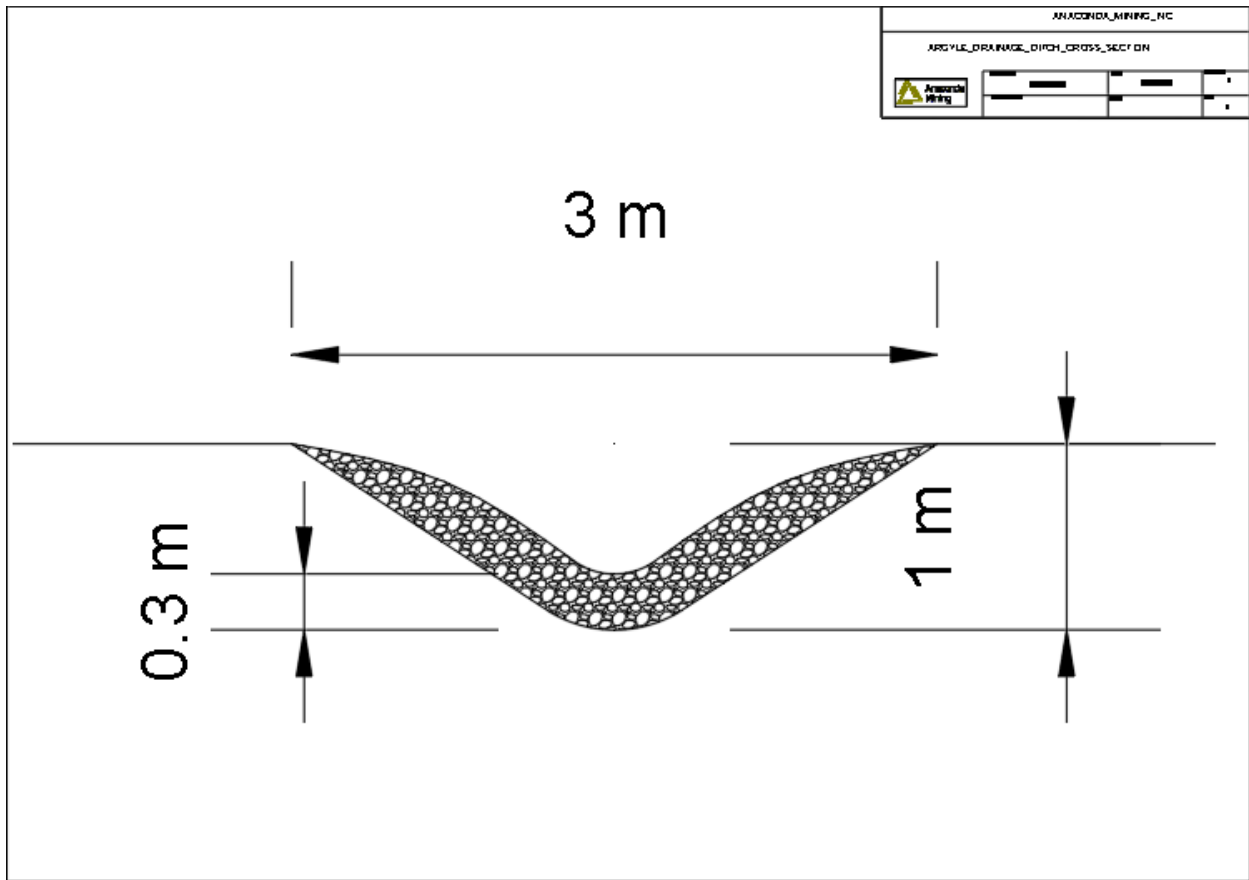

Figure 7 - Cross Section of Typical Proposed Drainage Ditch

Two options were considered for releasing water into the environment:

1. Discharging to the North – This option would include a pump and piping network that would transfer water from a large settlement pond north of the Argyle East Pit to the natural overflow stream of Bear Pond (a pond within the Town of Ming’s Bight Water Supply). The piping network (approximately 533m of 6” HDPE pipe) would remain on Anaconda’s Mineral License, and no released water would enter the Town of Ming’s Bight Water Supply.
2. Discharging to the South – This option would include a pump and piping network that would transfer water from a large settlement pond located at the south of the Argyle site to a natural stream that runs west to east, south of the Argyle site.

The two options considered for discharging are displayed in Figure 8. The red lines represent the anticipated location of the piping system for each option, and the fuscia line represents a possible adjustment to the Town of Ming’s Bight Water Supply boundary, proposed by Water Resources. The blue lines represent the natural stream channels currently existing. The shaded area represents the Town of Ming’s Bight Water Supply reservoir. Arrows have been added to display the direction of flow.

Option #1 was chosen based on the level of risk involved in potentially affecting the Town of Ming’s Bight. Option #1 involves discharging water into a natural stream channel that will eventually lead into the ocean. Water quality is not anticipated to be an issue as testing must occur and water meet certain guidelines prior to being discharged. The piping network will lead to the outflow of Bear Pond, part of the Ming’s Bight water supply. However, as water will be discharged into the outflow stream approximately 50 m from the boundary, no water will enter the Town of

Ming's Bight Water Supply. The water will then follow the outflow path until connecting with the ocean north of Ming's Bight.

Option #2 involved discharging water over a shorter piping network into another natural stream channel. However, the discharged water would have to travel through three road crossings: two of HWY 418 and one service road in the Town of Ming's Bight. The increased water flow may have the potential to affect the crossings, as they would have been designed based on a flow that does not take into account the discharge rate from The Project. As well, the natural stream for Option #2 would travel directly through the Town of Ming's Bight before discharging into the ocean. Although the water would be of suitable quality to be discharged into the environment, it was determined that avoiding the road crossings and not going through the Town is the best course of action. Therefore, the option of discharging to the north of The Project to avoid these potential issues was chosen.

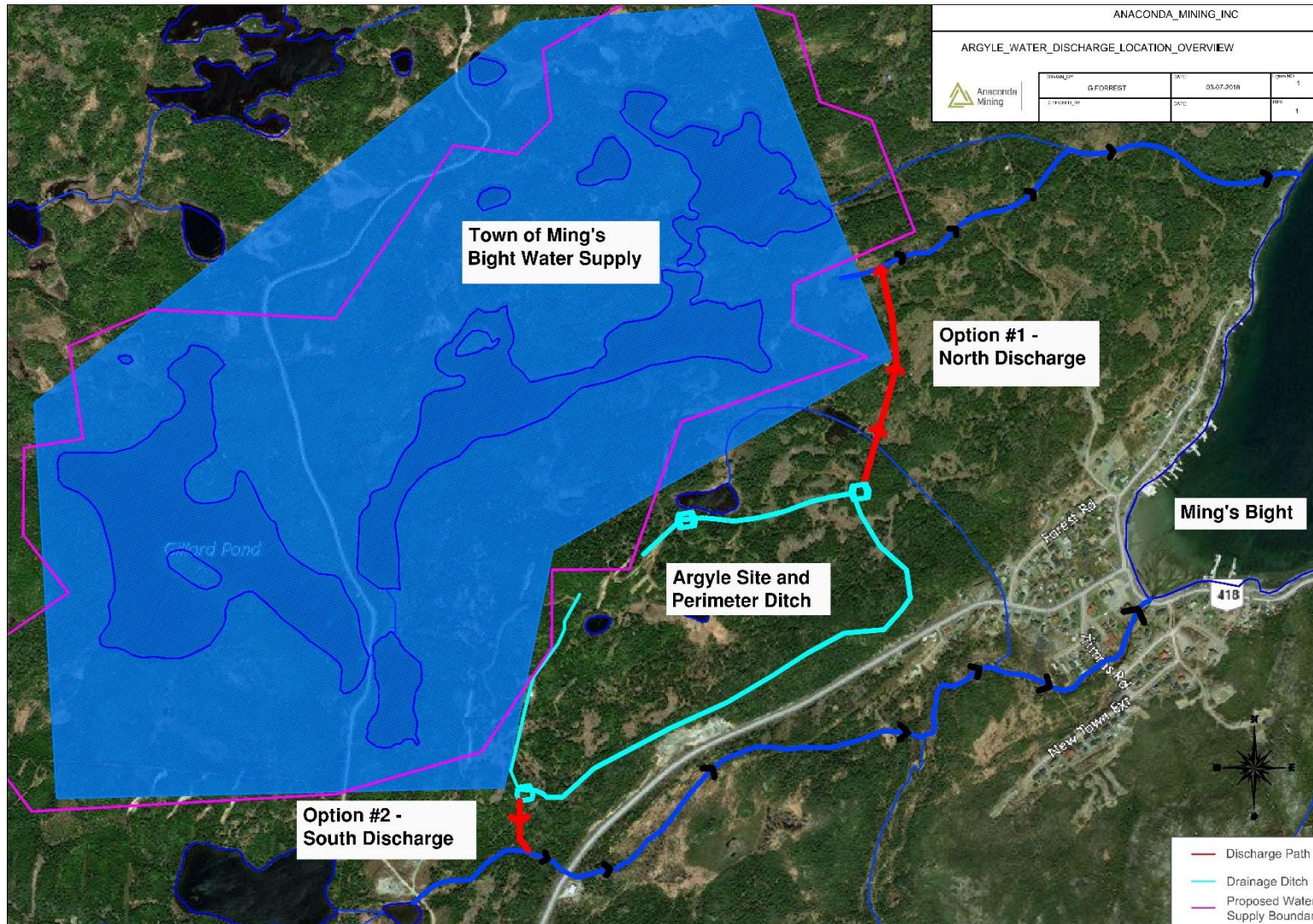

Figure 8 - Options for Discharging Water into the Environment

Initial desktop studies indicate that the latter portion of the natural stream draining from the Bear Pond/Water Supply to the ocean consists of a steep gradient (50%-60%). This occurs over the last 60 m of channel prior to entering the ocean along the shoreline. This gradient over this distance is unsuitable for fish passage, indicating that no fish are likely entering the stream from the ocean. Additionally, visual inspection by Anaconda indicates that there are no fish present. However, further studies will be carried out to conclude that this natural stream is not a fish habitat when completing the Permit to Alter a Body of Water (to discharge water into the stream) and establishing the Final Discharge Point location for discharging water from The Project. If fish habitat is discovered, action will be taken to redirect the discharged water, or provide an alternate habitat.

The release of water will consist of a pump and pipe system that will discharge water onto a boulder/cobble splash-pad to reduce the kinetic force of the discharged water and prevent erosion. The water will then follow a natural drainage channel into the environment, ultimately reaching the ocean. The natural drainage channel does not enter the Town of Ming's Bight water supply, but rather leads away from the boundary. Discharging of water will be monitored to ensure that the drainage channel is not over-loaded with flow, and to ensure no erosion occurs downstream of the discharge point. If erosion is detected, the discharge will be stopped, and measures will be taken to mitigate the erosion. This may include the placement of rip-rap, reinforcing eroded areas, or re-evaluating the discharge location options.

4.3.3.2 Noise and Vibrations

During the construction phase of the project, noise will consist of the following activities:

- Overburden removal activities
- Tree Cutting (chainsaw)
- Excavating and Blasting
- Equipment mobilization and road construction
- Transportation

The Project is approximately 500 m from the nearest town (Ming's Bight). A detailed blasting procedure and Best Management Plan: Argyle Blasting Activities will be developed prior to blasting operations commencing at The Project. This procedure will be made available to residents of Ming's Bight. Goldcorp's document titled Hollinger Project: Best Management Plan outlines various protective measures and procedures established for blasting at Goldcorp's Hollinger Mine, an open pit mine immediately adjacent to the downtown core of Timmons, ON. This document will be used as a reference to establish a Best Management Plan for blasting at The Project, addressing concerns related to noise and vibrations, dust generation, and flyrock. Consultation with the Town of Ming's Bight will be conducted to ensure there are no issues with the Best Management Plan for blasting at Argyle prior to blasting activities commencing

Table 4 shows the anticipated noise levels expected from the anticipated construction and operational activities at a 500m distance (using the inverse square law for determining noise at various distances). (https://www.fhwa.dot.gov/environment/noise/construction_noise/handbook/handbook09.cfm)

A detailed blasting procedure and Best Management Plan: Argyle Blasting Activities will be developed prior to blasting operations commencing at The Project. This procedure will be made available to residents of Ming's Bight. Goldcorp's document titled Hollinger Project: Best Management Plan outlines various protective measures and procedures established for blasting at Goldcorp's Hollinger Mine, an open pit mine immediately adjacent to the downtown core of Timmons, ON. This document will be used as a reference to establish a Best Management Plan for blasting at The Project, addressing concerns related to noise and vibrations, dust generation, and flyrock. Consultation with the Town of Ming's Bight will be conducted to ensure there are no issues with the Best Management Plan for blasting at Argyle prior to blasting activities commencing.

Table 4 - Typical Construction and Operational Equipment/Activity Noise Levels

Equipment/Activity	Noise Levels at source (dBA)	Estimated Noise Levels at 500m (dBA)
Blasting	94	64
Chainsaw	84	54
Dozer	82	52
Dump Truck	76	46
Excavator	81	51
Front End Loader	79	49
Generator	82	52
Grader	85	55
Pickup Truck	75	45
Pneumatic Tools	85	55

Blasting activity will result in the highest levels of noise, but for short durations. The blasting perimeter, used as a safe distance perimeter from the location of the blast for personnel at Point Rouse operations, is 500 m from the blast.

The Construction Noise Handbook (US Department of Transportation) states that at 15 m, blasting will result in a noise generation of 94 dBA. At 500 m, this will result in a noise generation of 64 dBA, using the inverse square law for determining noise levels at various distances. According to the Model Noise Control By-Law guidance document, developed by the Newfoundland and Labrador Department of Environment and Labor in 1997, the maximum noise generation in a rural area between the hours of 7:00 a.m. and 7:00 p.m. is 65 dBA. Therefore, the blasting activities should result in lower noise generation than the maximum levels. All operations at The Project will be between the hours of 7:00 a.m. and 7:00 p.m. (typical day is 7:00 a.m. to 5:30 p.m.), meaning no activity should exceed the maximum noise generation levels. Blasting plans and procedures will be created with the aid of the local blasting contractor and will include means to reduce the potential adverse effects of both noise and vibrations. These include proper burden and spacing in blasting designs and the use of an acceptable stemming material. Newfoundland Hard-Rok (blasting contractor) has extensive experience blasting near roads and municipalities. Smaller blasts will be planned early in The Project construction activities to build experience and determine what blasting parameters enable operations without exceeding the noise thresholds.

A portable noise detector (PCE Model MSM 4) was acquired to establish baseline noise data at The Project and in the Town of Ming’s Bight. This detector will be mounted in the field to record data over 24-hour periods. Noise will be recorded at various locations around the perimeter of Argyle, and in the Town of Ming’s Bight. These areas will be monitored for noise as construction activities progress (on a monthly basis, as a new construction or operation activities commence, and during blasts) to gather and record information. This will enable Anaconda to track any trending noise data and react to any activities that generate noise approaching the threshold limits. If the threshold limits are approached (a construction or operation activity generating noise consistently at 90% of the

limit, or exceeds the limit in a particular instance), methods to mitigate the noise will be implemented. This may include altering the operation to direct equipment to a different area of the site, addressing any equipment maintenance issues, or constructing a sound dampening barrier to deflect the noise. Monitoring will continue until the mitigation methods are successful.

A pre-blast survey will be completed on all buildings and dwellings within 550 m of the Argyle site (50 m outside of the 500 m blast radius). A portable seismograph (belonging to NFLD Hard-Rok) will be brought to the Point Rousse Project to determine blasting vibrations created by blasting at Stog'er Tight activities. This will be done to develop a safe blast design that will limit vibrations generating a particle velocity to 50 mm/s at 500 m. This value has been obtained from Halifax Regional Municipality By-Law B-600 – Respecting Blasting, as there were no regulations for blasting vibrations in an NL municipality. This blast design will be used at The Project as an initial design. The seismograph will also be used for the first blasts at The Project to determine the vibrations at 500 m near the Town of Ming's Bight. The design will be adjusted until this level is achieved. Blast designs can be adjusted by hole diameter, depth, spacing, stemming material and stemming depth.

Notices regarding safety and contact information will be provided to the residents of Ming's Bight prior to construction and operation activities commencing. Residents can contact Anaconda with any feedback or comments via email, phone, or in a scheduled meeting.

4.3.3.3 Air Emissions

All company and contractor vehicles and equipment are required to be in good and safe operating conditions, with vehicle emissions within limits established in Schedule F of the NL Air Pollution Control Regulations, 2004. All diesel heavy equipment will be Tier 4 approved engines.

Air quality tests for metals content will be conducted at The Project and at the Town of Ming's Bight to establish baseline data regarding air quality in these areas prior to construction activities beginning. Anaconda has been in contact with an external consultant to determine appropriate methods of sample collection and data analysis. Sample collection will be based on ASTM D1739-98 (2017) – Standard Test Method for Collection and Measurement of Dustfall. Although the test is based on dustfall, the sample collection method is sufficient for gathering a sample for determining metals content. These samples will be collected at four (4) locations around The Project site (north, east, south, and west). Sampling four locations around the perimeter will provide information on where any particulates are falling outside of the site area, particularly with regards to The Town of Ming's Bight and the Town's Water Supply. As well, samples will be collected in the Town of Ming's Bight. Sample collection will continue on a quarterly basis to capture seasonal changes in weather and environmental conditions, or as a new construction activity commences, to determine if dust is being generated and leaving the site perimeter. Testing of the samples will be completed by a third party (laboratory).

If levels of a particular contaminant are trending towards the maximum allowable limit, methods to mitigate the issue will be implemented. This may include assessing an operating procedure for a particular activity, testing to determine the source of the metals content, or constructing a berm to prevent particulates in the lower levels of the air from leaving the site. Mitigation methods will be implemented until the issue is resolved.

Greenhouse Gases (GHG) may be generated by diesel fuel combustion from heavy equipment (and possible diesel power generation if an emergency arises – power outage), gasoline consumption from light-duty vehicles, and blasting activities utilizing diesel-based blasting agents. These GHG include carbon dioxide (CO₂), methane (CH₄), and nitrous oxide (N₂O). Using The Climate Registry (TCR) 2016 Default Emission Factors, the total carbon emissions during peak construction and operating conditions at The Project were determined. This was completed using average fuel consumption for heavy equipment and light duty vehicles at Pine Cove operations over the past calendar year. As well, fuel consumption in the form of bulk emulsion for blasting was obtained from the blasting

contractor for Anaconda in 2017 (NFLD Hard-Rok, 2017). Table 5 displays the fuel consumption assumptions for equipment at The Project. Table 6 displays the GHG emissions for The Project.

Table 5 - Anticipated Fuel Consumption by Equipment Type at The Project

Equipment Type	Fuel Consumption, per day		Quantity of Equipment	Total Annual Consumption (252 operating days/year)
	Diesel (L)	Gasoline (L)		
Light Duty Vehicle	-	20.6	5	25956
460E JD Haul Truck (ADT)	450	-	5	567000
470GLC JD Excavator	450	-	1	113400
Diesel Generator	-	-	1	500

Table 6 - Anticipated GHG Emissions for The Project

	Quantity of Fuel L	Emissions Factors (TCR)			Emissions			CO2e Emissions			Total
		CO2 kg/L	CH4 g/L	N2O g/L	CO2 tonnes	CH4 tonnes	N2O tonnes	CO2e tonnes	CH4 CO2e tonnes	N2O CO2e tonnes	
Stationary Combustion (i.e., boilers, furnaces, etc.)											
Diesel	0.00	2.663	0.133	0.4	0.00	0.00	0.00	0.00	0.000	0.000	-
Propane	0.00	1.51	0.024	0.108	0.00	0.00	0.00	0.00	0.000	0.000	-
Subtotal											-
Electricity Generation (i.e., diesel generators)											
Diesel	500.00	2.69	0.15	1.1	1.35	0.00	0.00	1.35	0.002	0.164	2
Subtotal											2
On-Site Mobile Equipment (i.e., heavy equip & light vehicles)											
Diesel	680,400.00	2.69	0.15	1.1	1,830.28	0.10	0.75	1,830.28	2.552	223.035	2,056
Gasoline	25,956.00	2.316	2.7	0.05	60.11	0.07	0.00	60.11	1.752	0.387	62
Jet A1	0.00	2.342	2.2	0.23	-	-	-	0.00	0.000	0.000	-
Subtotal											2,118
Mining Explosives											
Fuel for Fossil Based Explosives	9,353.00				19.97			19.97			19.97
Subtotal											20
	716,209.00								Total Tonnes CO2e --->		2,140

The total annual attributable tonnes of CO₂e produced for The Project is anticipated to be approximately 2140. GHG emissions attributable to The Project are below the reporting thresholds prescribed by the Environment and Climate Change Canada (ECCC) GHG Emissions Reporting Program (GHGRP) and the NL Management of Greenhouse Act, which are 50,000 and 15,000 annual metric tonnes, respectively. Anaconda is dedicated on minimizing the carbon emissions not only at The Project, but at all sites within the Point Rouse Project. These values will be re-assessed on an annual basis, or if there is a drastic change to construction or operation activities, to ensure there is a constant awareness of the carbon emissions.

4.3.3.4 Dust

Construction activities may generate dust on the roads. If needed, water trucks will be used to mitigate and eliminate any dust situations. Water trucks have proven to be sufficient for dust suppression at the other Point Rouse operations.

Blasting activities have the potential to create airborne dust particulates. Based on experience with blasting at Pine Cove and Stog'er Tight, blast-generated dust is typically localized directly over the open pit/blasting area. However, mitigation methods will be implemented if dust becomes an issue from blasting (see final paragraph in this section).

Prior to construction activities commencing, samples will be collected to determine the dustfall around The Project site, and within the Town of Ming’s Bight, to develop baseline information for future comparison regarding dust particulates leaving The Project. Anaconda has been in contact with an external consultant to determine appropriate methods of sample collection and data analysis. Sample collection will be based on ASTM D1739-98 (2017) – Standard Test Method for Collection and Measurement of Dustfall. These samples will be collected at four (4) locations around The Project site (north, east, south, and west). Sampling four locations around the perimeter will provide information on where any particulates are falling outside of the site area, particularly with regards to The Town of Ming’s Bight and the Town’s Water Supply. As well, samples will be collected in the Town of Ming’s Bight. Sample collection will continue on a quarterly basis to capture seasonal changes in weather and environmental conditions, or as a new construction activity commences, to determine if dust is being generated and leaving the site perimeter. Testing will be completed by a third party (laboratory).

If it is found that dust is leaving Argyle, measures will be taken to either eliminate or reduce the generation of the dust, or to suppress it in a manner that will prevent it from leaving the site. This may be through the use of water cover, water curtains, environmental protection berms, or changing of an operating procedure for a particular activity.

4.3.3.5 Fuel and Lubricants

Construction activity poses a risk for the release of diesel fuel and lubricants from construction equipment. Anaconda will ensure that all contractor’s and company equipment are inspected daily to ensure no hydrocarbon leaks occur.

During the construction stage, equipment will be fueled by a service vehicle, owned by a contractor. This vehicle will get fuel from the approved storage tanks at Pine Cove and will carry spill kits in the case of an emergency. Spill kits will also be available on site in the case of an emergency.

Used oils and lubricants will be contained in proper bins at Pine Cove and disposed of with a local waste oil handler, as is done at the existing Point Rouse operations. No used oils or lubricants will be stored at The Project.

Anaconda has also developed the internal documents *Emergency Response Plan (ERP)*, *Environmental Protection Plan (EPP)*, and *Contingency Plan* for reference in the case of an emergency regarding fuel or oil spills, among other environmental concerns. These documents are attached in Appendix E, F, and H respectively.

4.3.3.6 Sewage

Sewage will be contained by an approved on-site holding tank, in accordance with NL’s Environmental Control Water and Sewage Regulations. The holding tank will be emptied by a contractor and pump truck on a regular basis. The sewage tank will be removed after the completion of the mining operations.

4.3.3.7 Waste and Garbage

All solid waste (wood, steel, etc.) and small garbage will be collected and hauled to an existing local municipal landfill facility, with permission of the operator, on a regular basis. Any food or organic garbage onsite will be held in animal-proof containers to prevent attracting wildlife. All such foods and scraps will be removed daily. Anaconda has developed and implemented a Waste Management Plan (Appendix G) for the Point Rouse Operations that will be followed for The Project. NL’s Waste Material Disposal Act will also be abided by when removing debris and waste materials from The Project.

4.3.3.8 Potential Resource Conflicts

As per the Environmental Baseline Studies Report (Appendix A), The Project is considered to be situated in an area of low archaeological potential, and as such there are no concerns with potential historical resource conflict. If, however, historic resources are encountered, operations in the area of the discovery will stop and the proper authorities will be notified in accordance with the Historic Resources Act (1985).

4.4. Operation

The operation of the Project has been broken down into mining, transporting ore, and milling. Operation activities are anticipated to begin in June 2019.

4.4.1.1 Proposed Mining

The Project is being developed as a combination of open pits and stockpiles with a cumulative total area, at surface, of approximately 37.5 ha. when production is complete. The combination of open pits includes the Argyle West Pit and Argyle East Pit. It is anticipated that approximately 171,000 t of ore at 1.42 g/t Au and 428,000 t of waste rock will be removed from the Argyle West Pit. It is anticipated that approximately 234,000 t of ore at 2.09 g/t Au and 1,800,000 t of waste rock will be removed from the Argyle East Pit. These quantities assume a cut-off grade of 0.8 g/t Au (determined using costs from previous mining activities in the Point Rouse Project) and a dilution factor of 20%.

Mining operations are anticipated to include an average of 530 tonnes per day (tpd) of ore material, and an average of 3550 tpd of waste material. The Project ore material will be combined and blended with marginal ore that has been mined and stockpiled from Pine Cove pit operations (Marginal ore grade at Pine Cove was approximately 0.5 g/t Au). This will be done to achieve the required throughput for milling operations at Pine Cove. The Pine Cove marginal ore (low grade ore) has been tested and is not found to be acid-generating (Refer to Page 4 and Table 3-2 of the attached Jacques Whitford Limited ARD Report on Pine Cove Material – Appendix K). The milling throughput will be blended to achieve 1280 tpd throughput, which is the total that the Pine Cove Mill is permitted for. Detailed mining plans will be finalized for the Development Plan submission.

The design/selection process for pit optimization was based on five-meter contour intervals. The benches were quadrupled to a final height of 20 m with berm widths of 8 meters and a batter (bench face) angle of 75 degrees. The ramp style is designed as a switchback type ramp system along the south wall of the East and West Pits. This configuration results in an overall inter ramp pit slope of approximately 60 degrees on the north face and 35 degrees on the south face, which was ascertained to fit all slope requirements for design. A switchback ramp was chosen to keep the access/egress on the footwall of the deposit. This enables possible expansion of the pit without loss of the ultimate ramp, as the deposit is open at depth. Additionally, with the West Pit, the ramp on the footwall will enable pit development without crossing into the Town of Ming's Bight water supply boundary. Some bench heights were reduced to 5 and 10 meters to accommodate localized pit bottom access as well as for minimizing incurred waste tonnage while accessing shallower dipping ore zones. The general design characteristics of the pits at The Project are based on previous experience using similar parameters at Pine Cove and Stog'er Tight operations.

The main access ramps are designed at a -10% gradient to accommodate articulated haul trucks. The width of these ramps is designed at 15 meters to facilitate two-way truck traffic at all points, assuming that the production haulage truck would be a 460E John Deere ADT unit with a 44-tonne capacity. Final pit bottom access ramps (final 40m of depth) are designed at a gradient of -10% and a width of 10 meters to accommodate one-way traffic. This method was used at Pine Cove operations and proved to be effective.

Table 7 and Table 8 summarize the parameters used for the preliminary East and West pit designs, respectively. Tonnages are based on a cut-off grade of 0.8 g/t Au and a dilution factor of 20%.

Table 7 - Design Parameters for Preliminary East Pit Design

Parameter	Quantity/Value
Pit Wall Slope Angle	75
Slope Angle, Overall North Face	60
Slope Angle, Overall South Face	30
Depth, Max [m]	74
Depth, Min [m]	59
Lowest Elevation in Pit [m]	76
Bench Height, Each [m]	5
Bench Height, Total [m]	20
Catchment Berm Width [m]	8
Ramp Width, Upper [m]	15
Ramp Slope, Upper [%]	10
Ramp Width, Lower [m]	10
Ramp Slope, Lower [%]	10
Ore [t]	234,000
Grade [g/t]	2.09
Waste [t]	1,800,000
Footprint Area, Max [m ²]	32,500

Table 8 - Design Parameters for Preliminary West Pit Design

Parameter	Quantity/Value
Pit Wall Slope Angle	75
Slope Angle, Overall North Face	60
Slope Angle, Overall South Face	30
Depth, Max [m]	35
Depth, Min [m]	25
Lowest Elevation in Pit [m]	126
Bench Height, Each [m]	5
Bench Height, Total [m]	20
Catchment Berm Width [m]	8
Ramp Width, Upper [m]	15
Ramp Slope, Upper [%]	10
Ramp Width, Lower [m]	10
Ramp Slope, Lower [%]	10
Ore [t]	171,000
Grade [g/t]	1.42
Waste [t]	428,000
Footprint Area, Max [m ²]	17,000

The waste stockpile at The Project is located to the south of the open pits. The stockpile was designed using an embankment slope of 1.5:1, 3 m catchment berm widths, and 6 m bench heights (overall slope of 2:1). The total volume capacity of the planned stockpile is approximately 1,800,000 t. For the proposed mining activities, the

waste stockpile and utilization of the west pit for waste rock storage (west pit will be backfilled post mining) will suffice for storage of all Argyle waste rock (total waste quantity of approximately 2,230,000 t, storage capacity of 2,400,000 t). The location of the waste dump was determined based on the nature of the deposit. Drilling to the south of the deposit resulted in no intersections with mineralized material resulting in ore. As well, it is known (from drilling results) that the deposit is open to the east and west, and at depth dipping towards the north. Therefore, all infrastructure was located to the south of the pits (ore, waste, organics, roads, etc.). The waste and organic stockpiles were also offset 15 m from the crest of the steep embankment between the Argyle site and Highway 418 (Ming’s Bight Road). The waste and organics stockpiles to the south will also act as a protective berm/barrier between the open pits and Ming’s Bight/Highway 418. This will support noise and dust suppression during the construction and operational phases of The Project. Sections of the final waste stockpile are displayed in Appendix I. Waste stockpile inspections will take place on an annual basis to ensure safety and stability, as is done at Pine Cove operations. These inspections will be completed by a third party geotechnical consultant. The organics stockpile is subject to change based on the total quantity of organics found on site when stripping/grubbing activities are ongoing. Table 9 summarizes the parameters used for the preliminary waste stockpile design.

Table 9 - Summary of Waste Stockpile Design Parameters

Parameter	Quantity/Value
Footprint Area [m ²]	69000
Height, Max [m]	67
Elevation, max [m]	177
Elevation, min [m]	110
Slope, Bench	1.5:1
Slope, Overall	2.0:1
Bench Height [m]	6
Bench Width [m]	3
Ramp Slope [%]	10
Ramp Width [m]	15
Capacity [t]	1,800,000

The pit planning will sequence the west pit be mined first, followed by the east pit. Once the west pit is mined out, it will be backfilled with waste rock from the east pit, and then capped with organics and seeded for reclamation. Once the east pit is completely mined out and operations cease, it will be allowed to naturally flood to the pit rim. The pit will then overflow naturally into the environment.

Blasting activities at The Project will be carried out using conventional mining explosives. Emulsion products will be pumping into drilled holes and detonated using electronic detonators to ensure safe and controlled blasts, as is done at the Pine Cove and Stog’er Tight operations. Blasting activities will take place between the hours of 07:00 – 19:00 on weekdays, and 12:00 – 19:00 on the weekend. Generally, blasting activities will take place during the week (Monday to Friday). Blasting at The Project will begin with smaller blasts to develop experience and determine what parameters will work in terms of limiting noise, vibrations, and dust (as discussed in previous sections). There are no available municipal by-laws for the Town of Ming’s Bight, so industry best practices will be used to limit noise, dust, and vibrations in the vicinity of the town. It is anticipated that noise and vibrations will be experienced in the Town of Ming’s Bight, but will be below the allowable limits (as discussed in previous sections).

Hole spacing, hole diameter, and stemming can be altered to develop a blast design that will not exceed any threshold limits for these parameters.

As previously mentioned, a safe blasting radius of 500 m has been established from previous mining experience. This radius of 500 m is the minimum distance required for personnel around a blast. A component of the blast procedure will include a blasting horn/siren at various intervals (i.e. 30 mins to blast = 5 long horn blows, 15 mins to blast = 3 long horn blows, 30 s to blast = 1 long horn blow) to warn the public of the blast. There is one (1) dwelling located within the 500 m blast radius. Mitigation methods will be implemented to limit blasting noise, vibrations and flyrock when blasting to prevent any damage to this dwelling. As well, weather conditions will be monitored to prevent blasting when the wind direction is to the east (toward the Town of Ming's Bight/dwelling). This will be done to prevent fly-rock from approaching the 500 m blast radius. At Pine Cove and Stog'er Tight operations, there has not been a blasting incident regarding fly-rock landing outside the 500 m blast radius.

A section of HWY 418 is within the 500m blast radius. Traffic control will be established (signage, flagging personnel with portable radios, barricades) to prevent any pedestrian/vehicular traffic from entering the blast radius during blasting activities. As per Section 435.6(b) of the NL Occupational Health and Safety Regulations, 2009, warning signage will be posted 300m before entering the blast radius, at which point pedestrian and vehicle traffic will be stopped, when required. On the section of road near the Town of Ming's Bight, sufficient signage will be installed along the road to notify residents of blasting operations (as the town is within 300m of the blast radius). This will include signage near the town reading '**Blasting Operations: Be Prepared to Stop**'. All residents near the blast radius will be notified of the Blast 24 hours in advance. The blast alarm will also provide advanced warning to others in the area.

There will also be measures in place to stop the blast prior to detonation to allow for emergency vehicles to enter the blast radius, if required, along HWY 418. A detailed blasting procedure and *Best Management Plan: Argyle Blasting Activities* will be developed prior to blasting operations commencing at The Project. This procedure will be made available to residents of Ming's Bight. Goldcorp's document titled *Hollinger Project: Best Management Plan* outlines various protective measures and procedures established for blasting at Goldcorp's Hollinger Mine, an open pit mine immediately adjacent to the downtown core of Timmons, ON. This document will be used as a reference to establish a Best Management Plan for blasting at The Project. Consultation with the Town of Ming's Bight will be conducted to ensure there are no issues with the Best Management Plan for blasting at Argyle prior to blasting activities commencing.

The 500 m blast radius is shown in Figure 9.

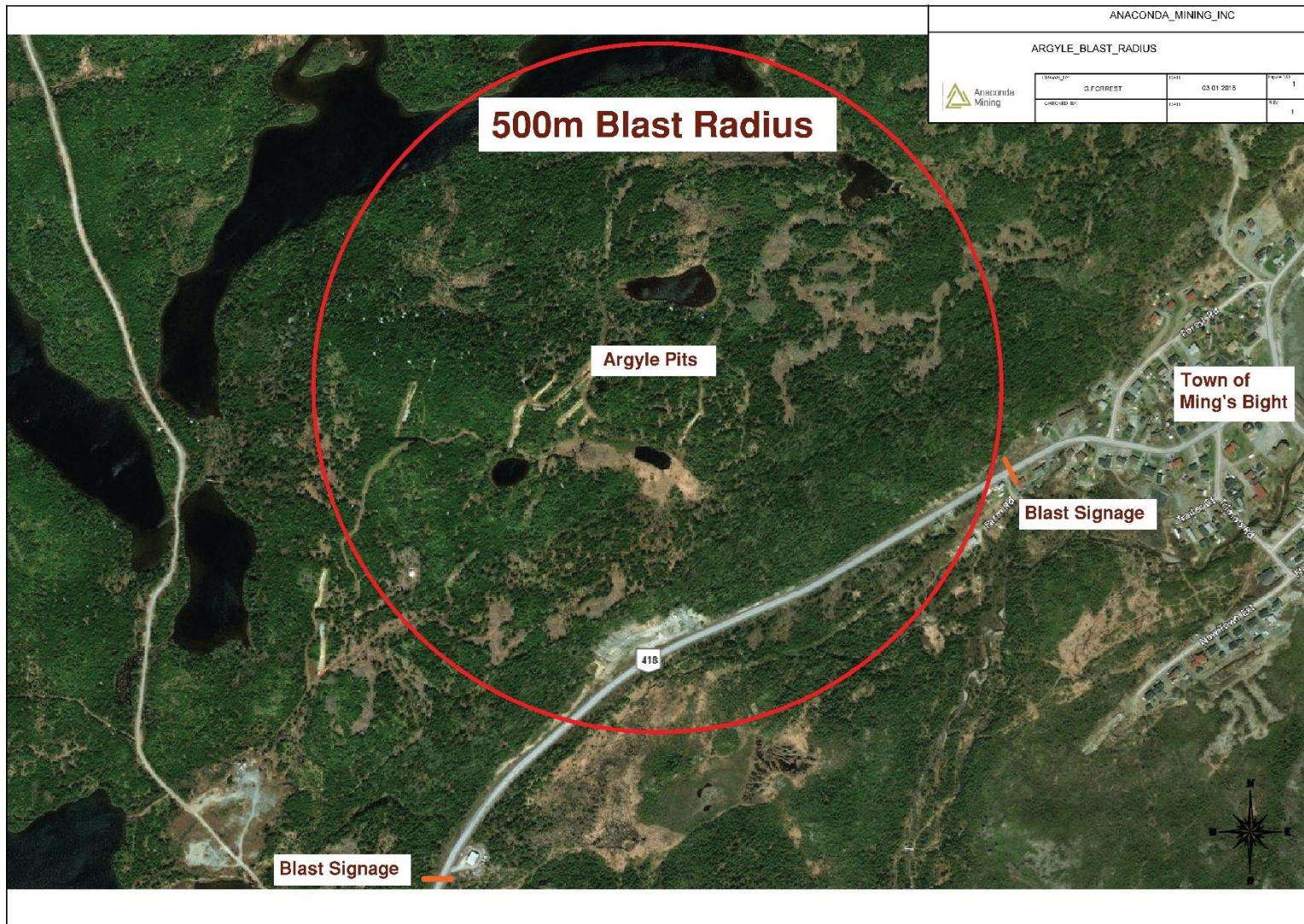

Figure 9 - 500 m Blast radius for Blasting Activities at The Project

Consideration was given throughout the design process to issues regarding existing topography, haulage roads, waste dump locations and drainage areas/ditches. During the design process, consideration was also given to providing adequate operational space requirements for equipment in areas approaching final design pit walls. The open pit has a minimum buffer of 15 m along the perimeter of the pit rim from any geographical feature (i.e. ponds/lakes). See Figure 5 for the conceptual design for the open pit and waste rock storage areas.

As mentioned in Section 4.1, the design of several features associated with The Project, including the design of the West Pit, have been adjusted to remain outside of both the existing and proposed water supply boundaries. Anaconda has been in discussion with Water Resources regarding the proposed water supply boundary changes. Water Resources intends on ground truthing the area to determine the actual boundary in the field. At this point, depending on the results of the ground truth survey, Anaconda may propose the option of temporarily adjusting the Town of Ming's Bight water supply intake further upstream, which would subsequently adjust the water supply boundary. This would be done in order to expand the West Pit design to recover remaining resources that are currently un-retrievable based on the existing and proposed water supply boundaries. Once mining activities are complete, the West Pit would be backfilled, as planned, and the area would be returned to as close as its natural condition as possible.

Adjusting the intake of the Town of Ming's Bight water supply would involve installing a pump and piping network to supply the water treatment system with sufficient water. The proposal would suggest relocating the intake to the North end of Mud Pond. This area is accessible by an existing forest access road. This proposal would require an analysis to determine the effect on the water supply boundary by removing Bear Pond from the water supply. Figure 10 outlines the potential water supply intake in comparison with the existing intake.

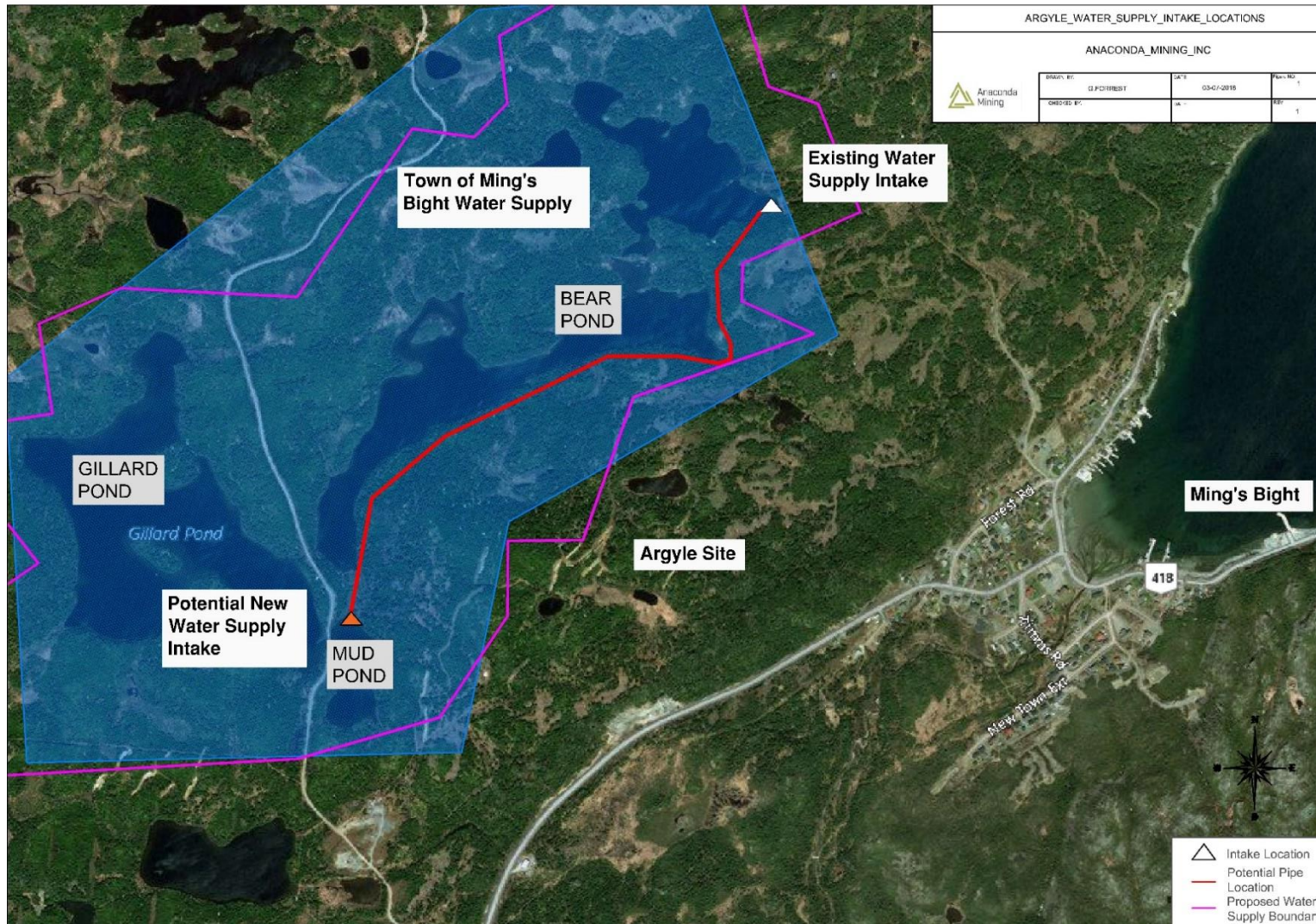

Figure 10 - Potential Relocation of the Town of Ming's Bight Water Supply Intake

Consultation would be undertaken with the required governing agencies and with the Town of Ming's Bight to ensure any work to be completed is sanctioned by all stakeholders.

4.4.1.2 Trucking of Ore

Ore from The Project will be briefly stockpiled on site prior to trucking to the Pine Cove Mill. The distance from The Project to the Pine Cove Mill facility is approximately 6.5 km. This trucking operation will utilize the additional access road connecting the forest access road (off HWY 418) and the Stog'er Tight property, the road network on the Stog'er Tight property, and the Pine Cove Mine access road. This transportation route can be seen in Figure 11. The yellow line represents the road network at Argyle and from Argyle to Stog'er Tight, the red line represents the road network at Stog'er Tight, and the blue line represents the Pine Cove access road. For reference, the location of the ore stockpile can be seen in Figure 5. The trucking operation will utilize rock trucks similar to those that will be used in the Mining operation.

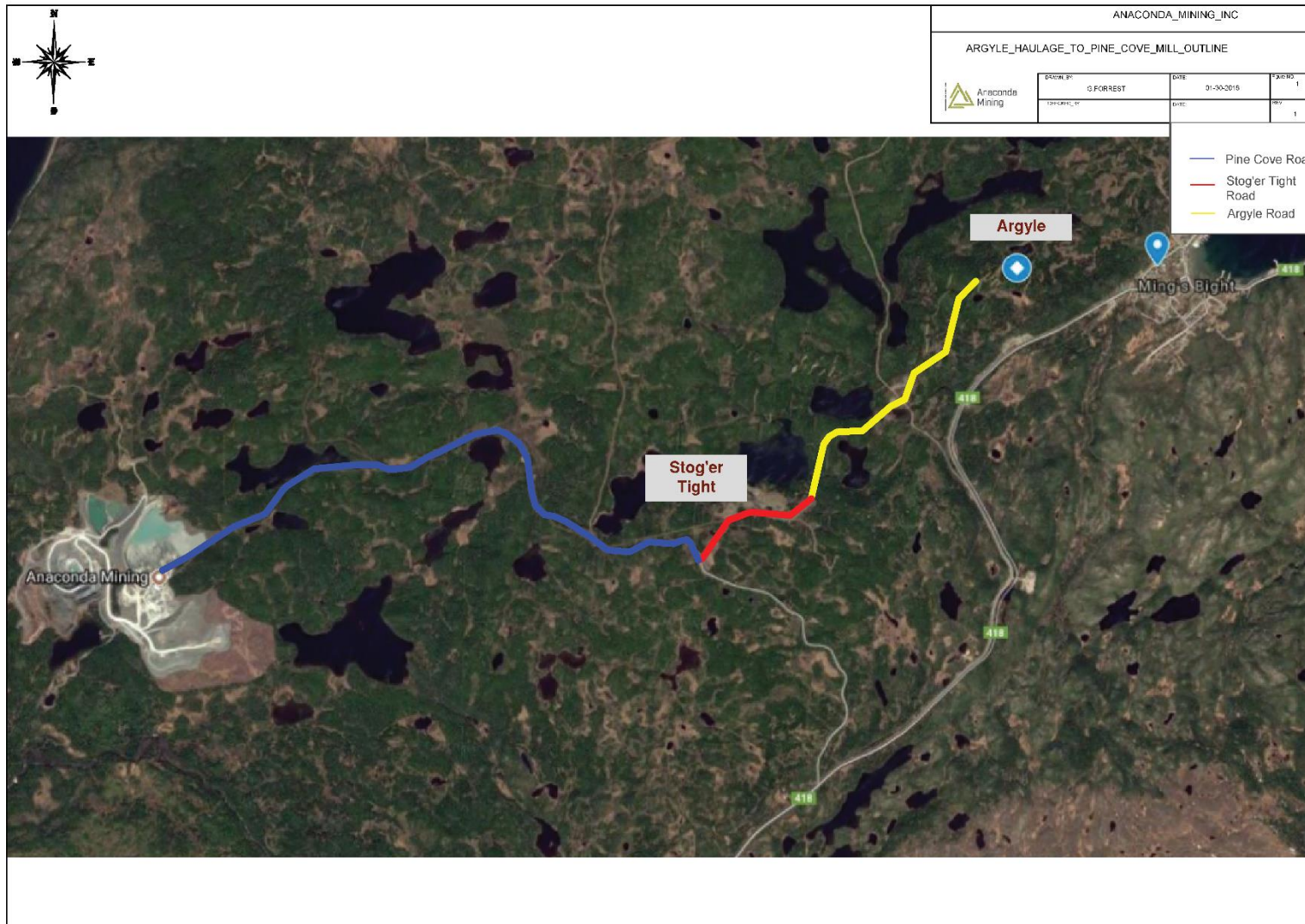

Figure 11 - Haulage outline from The Project to Pine Cove Mill

Precautions will be taken during ore transportation activities from The Project to the Pine Cove Mill to ensure the safety of the general public. Ore haulage will only occur on particular days in which weather conditions permit safe driving conditions on all roads. As well, ore haulage will occur only when ore is needed at the Pine Cove Mill, or when the stockpile at The Project has exceeded 20,000 t (maximum storage capacity to limit and minimize ore storage at The Project site). Precautions will include posted signage, road closures, and flagging personnel with radio communication. Procedures will be established to stop haulage activities in the case of an emergency.

4.4.1.3 Milling of Ore

Anaconda currently operates the already-permitted Pine Cove mill, which is located on Anaconda's Pine Cove property. The milling operation is currently processing material from the Pine Cove mine which is expected to be exhausted in 2018. Anaconda is planning to utilize the existing mill and permitted tailings facilities once the Pine Cove mine has ceased operation. Through testing at RPC (completed with the ARD testing), it was determined that no changes will be required to the mill circuit in order to effectively process the Argyle ore. A flotation recovery of 97.3% and a leach recovery of 94.5% were achieved, for a total recovery of 91.9%. These tests were conducted to determine the metallurgical characteristics and verify its compatibility with the existing circuits at the Pine Cove Mill. The metallurgical testing results completed by RPC are in Appendix J.

The mill process at the Pine Cove site consists of six major systems: crushing, grinding, flotation, leaching, drum filtration, and Merrill Crowe. Ore is fed to the crushing plant via front end loader, where it first enters a jaw crusher. After the jaw, a conveyor takes the ore to a screen deck, where fine material will pass through to the crushed ore stockpile, while oversize ore will be recirculated through a cone crusher until it reaches the desired top size of 3/8".

Ore from the crushed stockpile is then fed to the primary ball mill via conveyor belt, and typically ranges from 1.0 – 2.0 g/t Au. The ball mill is charged with 2" and 3" steel balls, and grinds material to a P₈₀ of 150 microns. Material from the ball mill is pumped through a cyclone, where the liberated material is fed to the flotation circuit via the overflow, while the coarse material is recirculated to the ball mill.

The flotation circuit at Pine Cove utilizes three rougher columns, one cleaner column, and one scavenger cell. PAX and MAXGOLD are introduced as collectors here, and MIBC as a frothing agent. Overflow material is sent to a thickener tank, typically at concentrations of 75-100 g/t Au. Tailings from the flotation circuit is pumped to the tailings facility via the final tailings pump. Flocculent is added to the thickener tank to increase the density of the slurry from 1300 kg/m³ to 1600 kg/m³.

The underflow from the thickener tank is pumped to a regrind mill, to further liberate the gold particles in preparation for the leaching process. The regrind mill is filled with ½" balls, and grinds material to a P₈₀ of less than 20 microns. The discharge of the regrind mill is fed to the leaching circuit, which consists of four large tanks, where cyanide solution, lime, and lead nitrate are added to the cyanidation process. The leaching takes 48 hours, on average, and yields upwards of 97% recovery of gold. Solution from the leach circuit is pumped to a series of rotary drum filters, which separate the high-grade gold containing solution from the solid tailings that will not leach any additional gold.

The solution from the drums is sent to a series of holding tanks, before finally entering the Merrill Crowe tower to complete the process. In the Merrill Crowe tower, zinc dust is added to precipitate the gold from the solution, back into a solid form where it will be collected in a filter press. Tailings from the press are sent to the final tailings pump. Once a week, the press is opened to remove the solid gold so that it can be refined into a dore bar. Figure 12, Figure 13, and Figure 14 show the Mill Recovery Flow Sheet, Process Diagram, and Recovery Balance for the Pine Cove Mill.

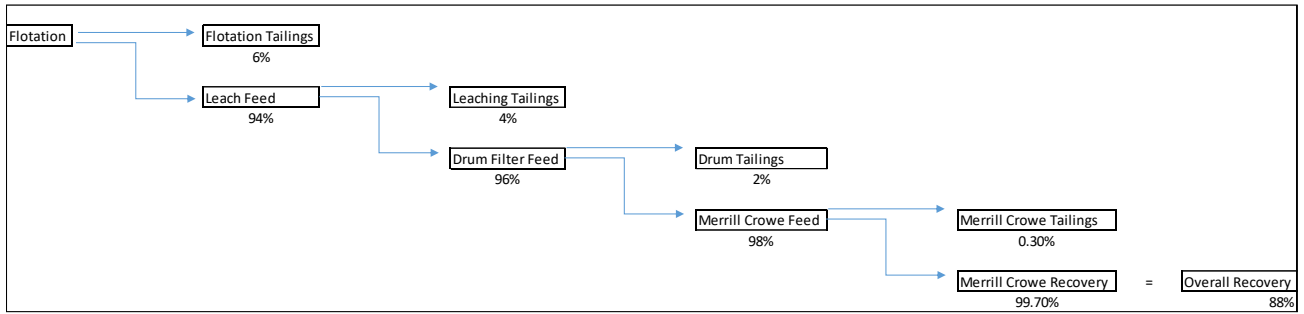

Figure 12 - Mill Recovery Flow Sheet

Process Flow Diagram at the Pine Cove Project

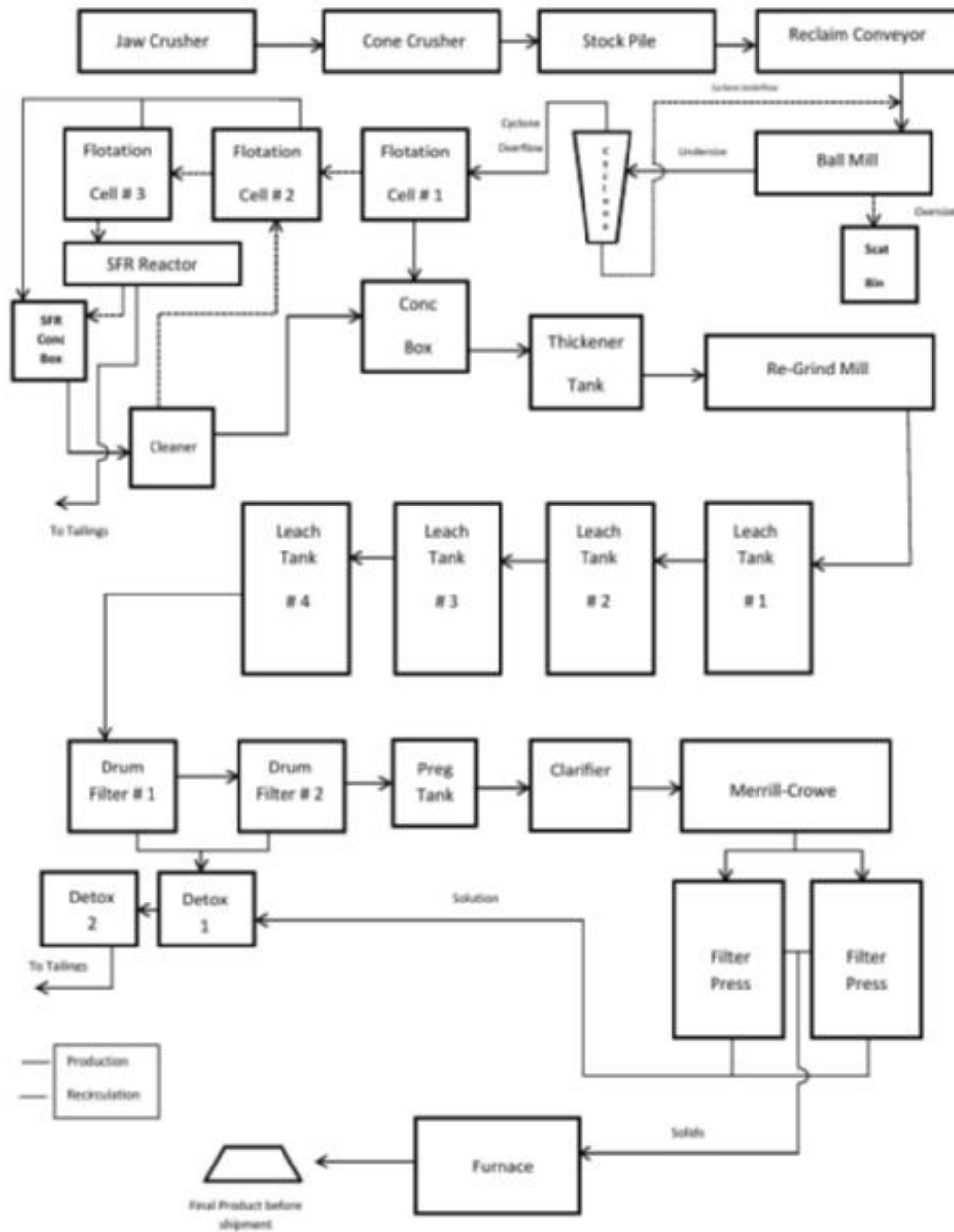

Figure 13 - Process Flow Diagram for Pine Cove Mill

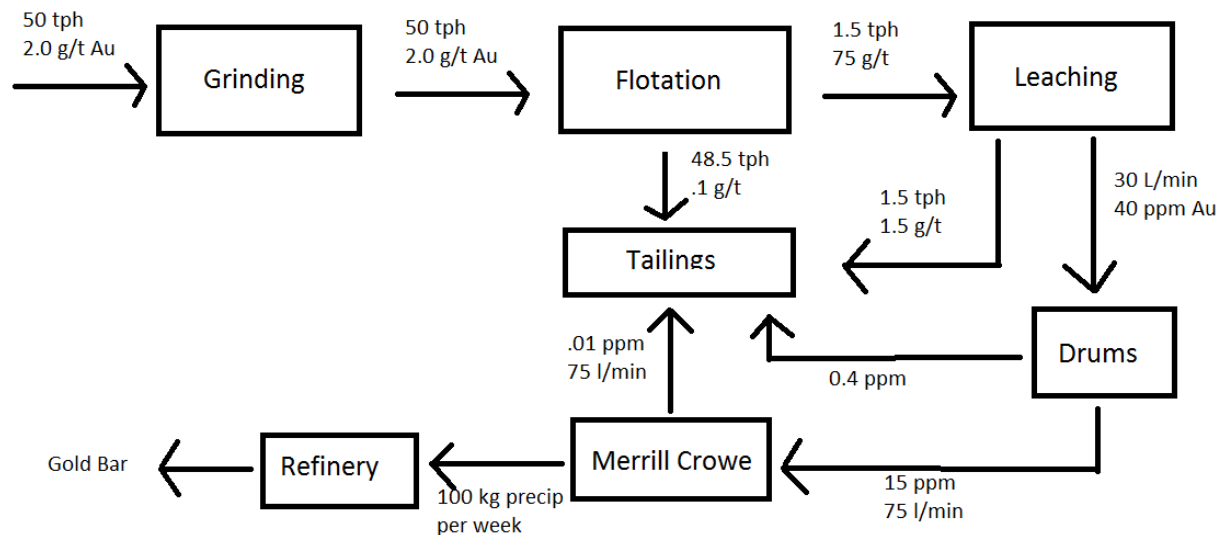

Figure 14 - Metallurgical Balance for the Pine Cove Mill

4.4.2 Potential Sources of Pollution during Operation

Potential Sources of pollution during the Operations stage are outlined in the following sections. Generally, potential sources of pollution for operation activities are similar to those outlined in the construction activities. Refer to Section 4.3.3 for additional details regarding all potential sources of pollution. Additionally, Anaconda has developed the internal documents *Environmental Protection Plan* and *Emergency Response Plan*. These plans have been generally developed based on the Pine Cove Site, as that has been the only active operational site for Anaconda. These documents will be updated to address any specific operational components involving The Project.

4.4.2.1 Water

Potential sources of pollution regarding water are similar in the operations phase as in the construction phase. Refer to Section 4.3.3.1 for additional information regarding the ditching/collection system, water management, and discharging to the environment.

During the operations stage, dust and fine material will have the potential to mobilize into ponds and streams around the site. To mitigate this, sediment-trapping material such as approved filtration fabrics will be used in areas subject to siltation and erosion. Water trucks will be used for dust suppression on the roads and stockpiles.

As required, standard mitigation methods such as on-site drainage ditch channels, collection sumps and settlement ponds will be used to control silt and sediment and prevent the introduction of contaminants into the Ming's Bight Water Reservoir, and from leaving The Project site in general. The water will be contained in a series of settlement ponds and tested until it meets all Final Discharge Point Requirements. See Figure 5 and Figure 7 in Section 4.3.3.1 for the proposed location and cross section of the ditching system at The Project. Water testing will take place regularly to ensure the water being released is of sufficient quality. Water that is released into the environment from The Project site will follow a natural drainage channel that does not enter the Town of Ming's Bight water supply. The discharge will be monitored to ensure no downstream erosion occurs.

Blast residues have the potential to be contaminants through ammonia by-products, which can be toxic to aquatic fauna. All such contaminants will pool in the deepest level of the pit where it will be captured and pumped to a

series of settling sumps. The discharge of all water exiting the settlement pond/ditching system will be done in accordance with applicable regulations. Through previous experience at the Pine Cove Operations, while the ammonia is detectable in the pit water, it is below toxic levels and does not contain contaminants that are above the threshold limits for discharging into the environment.

All ground and surface water entering the open pit will be pumped to the surface into a settlement pond where suspended solids will settle out prior to being re-introduced to the environment. The settlement pond will be sized to contain, at a minimum, 24 hours of maximum pumping capacity from the submersible pump being used in the pit, approximately 3500 m³. It is anticipated that the collection and settlement ponds will be between 5000 m³ and 15000 m³. As mentioned in Section 4.3.3.1, the MMER FDP criteria for various parameters of water quality will be tested for prior to discharging any collected water into the environment. These tests are completed by a third party.

4.4.2.2 Noise and Vibrations

Potential sources of pollution regarding noise and vibrations are similar for operational activities as they were for construction activities. Due to this, please refer to Section 4.3.3.2 for additional details regarding issues involving noise and vibrations. During the operations phase of the project, noise will consist of the following activities:

- Excavating and Blasting
- Equipment mobilization
- Transportation

The Project is approximately 500 m from the nearest town (Ming's Bight) and is much higher in elevation. It is not anticipated that noise generated from the operational phases will impact the residents. Refer to Table 4 for anticipated noise levels expected from the operational activities.

A detailed blasting procedure and Best Management Plan: Argyle Blasting Activities will be developed prior to blasting operations commencing at The Project. This procedure will be made available to residents of Ming's Bight. Goldcorp's document titled Hollinger Project: Best Management Plan outlines various protective measures and procedures established for blasting at Goldcorp's Hollinger Mine, an open pit mine immediately adjacent to the downtown core of Timmons, ON. This document will be used as a reference to establish a Best Management Plan for blasting at The Project, addressing concerns related to noise and vibrations, dust generation, and flyrock. Consultation with the Town of Ming's Bight will be conducted to ensure there are no issues with the Best Management Plan for blasting at Argyle prior to blasting activities commencing.

4.4.2.3 Air Emissions

Potential sources of pollution regarding air emissions are similar for operational activities as they were for construction activities. Please refer to Section 4.3.3.3 for additional information regarding air emissions and mitigation methods.

All company and contractor vehicles and equipment are required to be in good and safe operating conditions, with vehicle emissions within limits established in Schedule F of the NL Air Pollution Control Regulations, 2004. All diesel heavy equipment will be Tier 4 approved engines.

As discussed in Section 4.3.3.3 regarding construction activities, air quality tests for metals content will be conducted at The Project and at the Town of Ming's Bight during the operational phases of The Project. Sample collection will be based on ASTM D1739-98 (2017) – Standard Test Method for Collection and Measurement of Dustfall. Although the test is based on dustfall, the sample collection method is sufficient for gathering a sample for determining metals content.

Sample collection will continue on a quarterly basis to capture seasonal changes in weather and environmental conditions, or as a new operational activity commences, to determine if dust is being generated and leaving the site perimeter. If levels of a particular contaminant are trending towards the maximum allowable limit, methods to mitigate the issue will be implemented. This may include preventing equipment idling, assessing potential equipment maintenance issues, or constructing a berm to prevent particulates in the lower levels of the air from leaving the site. Mitigation methods will be tried until the issue is resolved.

Greenhouse Gases (GHG) may be generated by diesel fuel combustion from heavy equipment (and possible diesel power generation if an emergency arises – power outage) and gasoline consumption from light-duty vehicles. These GHG include carbon dioxide (CO₂), methane (CH₄), and nitrous oxide (N₂O). The equipment usage during construction activities and operational activities are expected to be the same. Using *The Climate Registry* (TCR) 2016 Default Emission Factors, the total carbon emissions during peak construction and operating conditions at The Project were estimated. This was completed using average fuel consumption for heavy equipment and light duty vehicles at Pine Cove operations over the past calendar year. Refer to Table 5 for the fuel consumption assumptions for equipment at The Project and Table 6 displays the GHG emissions for The Project (in Section 4.3.3.3).

The total annual attributable tonnes of CO₂e produced at The Project will be approximately 2140. GHG emissions attributable to The Project are below the reporting thresholds prescribed by the Environment and Climate Change Canada (ECCC) GHG Emissions Reporting Program (GHGRP) and the NL Management of Greenhouse Act, which are 50,000 and 15,000 annual metric tonnes, respectively. Anaconda is dedicated on minimizing the carbon emissions not only at The Project, but at all sites within the Point Rouse Project. These values will be re-assessed on an annual basis, or if there is a drastic change to operational activities, to ensure there is a constant awareness of the carbon emissions.

4.4.2.4 Dust

Potential sources of pollution regarding dust are similar for operational activities as they are for construction activities. Refer to Section 4.3.3.4 for additional information regarding dust pollution and mitigation methods.

Operation activities may generate dust on the roads at The Project. If needed, water trucks will be used to mitigate and eliminate any dust situations. Water trucks have proven to be sufficient for dust suppression at the other Point Rouse operations.

Blasting activities are capable of creating airborne dust particulates. However, based on experience with blasting at Pine Cove and Stog'er Tight, blast-generated dust is typically localized directly over the open pit/blasting area.

As discussed in Section 4.3.3.4, samples will be collected to gather baseline information regarding dustfall prior to any activities beginning at Argyle. As will be done with construction activities, sample collection will continue throughout the operational phases of Argyle to monitor dustfall around the perimeter of the site, and within the Town of Ming's Bight. Anaconda has been in contact with an external consultant to determine appropriate methods of sample collection and data analysis. Sample collection will be based on ASTM D1739-98 (2017) – Standard Test Method for Collection and Measurement of Dustfall. These samples will be collected at four (4) locations around The Project site (north, east, south, and west). Sample collection will continue on a quarterly basis to capture seasonal changes in weather and environmental conditions, or as a new operational activity commences, to determine if dust is being generated and leaving the site perimeter.

If it is found that dust is leaving The Project, measures will be taken to either eliminate or reduce the generation of the dust, or to suppress it in a matter that will prevent it from leaving the site. This may be through the use of water cover, environmental protection berms, or changing an operating procedure for a particular activity.

4.4.2.5 Fuel and Lubricants

Operations activities pose a risk for the release of diesel fuel and lubricants from construction equipment. Anaconda will ensure that all contractor's and company equipment are inspected daily to ensure no hydrocarbon leaks occur.

During the Operations stage, equipment will be fueled by a service vehicle, owned by a contractor. This vehicle will get fuel from the approved storage tanks at Pine Cove and will carry spill kits in the case of an emergency. Spill kits will also be available on site in the case of an emergency.

Used oils and lubricants will be contained in proper bins at Pine Cove and disposed of with a local waste oil handler, as is done at the existing Point Rouse operations. No used oils or lubricants will be stored at The Project.

Anaconda has also developed the internal documents *Contingency Plan* and *Emergency Response Plan* for reference in the case of an emergency regarding fuel or oil spills, among other environmental concerns. These documents are attached in Appendix F and Appendix E, respectively.

4.4.2.6 Sewage

Sewage will be contained by an approved on-site holding tank, in accordance with NL's Environmental Control Water and Sewage Regulations. The holding tank will be emptied by a contractor and pump truck on a regular basis. The sewage tank will be removed after mining activities have ceased and closure activities begin.

4.4.2.7 Waste and Garbage

All solid waste (wood, steel, etc.) and small garbage will be collected and hauled to an existing local municipal landfill facility, with permission of the operator, on a regular basis. Any food or organic garbage onsite will be held in animal-proof containers to prevent attracting wildlife. All such foods and scraps will be removed daily. Anaconda has developed and implemented a Waste Management Plan (Appendix G) for the Point Rouse Operations that will be followed for Argyle. NL's Waste Material Disposal Act will also be abided by when removing debris and waste materials from Argyle.

4.4.3 Potential Resource Conflicts

As per the Environmental Baseline Studies Report (Appendix A), The Project is considered to be situated in an area of low archaeological potential, and as such there are no concerns with potential historical resource conflict. If, however, historic resources are encountered, operations in the area of the discovery will stop and the proper authorities will be notified in accordance with the Historic Resources Act (1985).

4.4.4 Reclamation

4.4.4.1 Rehabilitation Plan

The primary objective of the rehabilitation planning and implementation is to leave the mine site as ecologically-friendly as possible, while maintaining long-term physical and chemical stability. Anaconda's approach to rehabilitation at The Project will be to employ advanced progressive and closure rehabilitation techniques through integrated development, operational, and closure technology and design.

All aspects of mine development including mine design, infrastructure location and design, and operations planning will be conducted with full consideration of available progressive rehabilitation opportunities and closure rehabilitation requirements. Baseline environmental studies conducted prior to site construction and operation will be compared to studies continued through the mine development and operations stages. The Project will use practices and procedures which have also been implemented into the Point Rouse Project. The mining activity

will be planned and designed to minimize the amount of post-production disturbance to the area of the site, and to minimize the environmental impact prior, during, and post-mine operations. Progressive rehabilitation will be conducted where possible. Organic material will be stockpiled and used for the reclamation of site and dump surfaces.

All rehabilitation and closure work will be described in the Rehabilitation and Closure plan, which will be submitted to the Department of Natural Resources. This plan will be completed based on the guidelines set out by the Department and will be subject to an official review and approval process from the Department. Closure rehabilitation will generally include the following:

- Dismantling and removal/disposal of all buildings and surface infrastructure. The rehabilitation and closure plans assume that all surface buildings and infrastructure to be demolished or removed have been cleaned of process materials and that all potentially-hazardous materials have been removed;
- Material and equipment will be removed from site. Equipment and demolition debris with no marketable value will be disposed of in a manner consistent with the disposal of other building demolition waste, and according to NL's Waste Material Disposal Act;
- Rehabilitation and stabilization of the remaining waste rock areas by grading and contouring to a stable slope angle to reduce erosion and sedimentation. The waste rock will subsequently be covered with a soil cap and revegetated;
- The Argyle West Pit will be backfilled with waste rock from the east pit during operations, at which point it will be covered with a soil cap and revegetated;
- The Argyle East Pit will be allowed to flood, creating a small lake with a final water surface at 132m elevation;
- In general, site drainage patterns will be re-established, as near as is practical, to natural, pre-development conditions;
- Grading and/or scarification of disturbed areas to promote natural revegetation, or the placement and grading of overburden for revegetation in areas where natural revegetation is not sufficiently rapid to control erosion and sedimentation;
- Safety berms (a minimum of 1 m in height) will be constructed at all areas with a slope greater than 30 degrees, or to prevent access to an area greater than 30 degrees, including the mined open pits;
- Attending to any special rehabilitation requirements associated with the site, such as removal of any culverts and power lines, and the infilling of any drainage or diversion ditches which are no longer required; and
- Anaconda will incorporate environmental measures in all contract work agreements and ensure all contractors abide by these rules and all environmental regulations set by Anaconda and all government regulatory agencies.

A post-closure monitoring program will continue from the operational monitoring program incorporating appropriate changes to the program. This monitoring program will be developed with the Closure Plan, to be completed in 2018. The post-closure monitoring program will remain in place for a minimum of five (5) years, or until Anaconda and the appropriate regulatory bodies are satisfied that all physical and chemical characteristics are stable. When the site is considered physically and chemically stable, the land will be relinquished to the Crown.

4.4.4.2 Water Testing

Water quality testing was carried out in 2017 to determine baseline conditions at The Project site. Field tests were collected at four locations, which will be used as water quality sampling stations in the future to maintain consistency. Samples were also submitted for chemical analysis and total metals.

Generally, the field parameters of the water samples were within the following results:

- Water temperatures were between 18.7 to 19.9 C
- Field pH ranged between 7.09 to 7.67

- Dissolved Oxygen ranged between 8.18 mg/L and 9.25 mg/L
- Conductivity ranged from 51.6 to 80.2 $\mu\text{S}/\text{cm}$

One sample that was collected during the baseline studies had a slightly higher concentration of aluminum (102 $\mu\text{g}/\text{L}$) than guidelines permit in the Canadian Council of Ministers of the Environment (CCME) Water Quality Guidelines for the Protection of Freshwater Aquatic Life (FWAL) (<100 $\mu\text{g}/\text{L}$). No other collected water samples had similar levels of aluminum. The sample collection area (WL3 in the Environmental Baseline Studies - Appendix A) was found to be groundwater fed and did not have an inlet or outlet. This area will continue to be monitored closely going forward to determine if the conditions return to below the allowable standards. Refer to Appendix A for the detailed Water Quality Testing results as outlined by GEMTEC.

Water samples will be collected at the same sample locations used by GEMTEC on a monthly basis, or as requested, to ensure there are no water quality issues developing. Anaconda is committed to water testing at The Project to ensure the safety and water quality of any water that leaves the project area. Anaconda has been in contact with the Town of Ming's Bight regarding this, with the Town of Ming's Bight continuing to support the Argyle Project. Water quality testing results will be made available to the Town of Ming's Bight, upon request.

Additionally, when water is being discharged from the Argyle area, water samples will be collected for third-party testing to ensure the quality is sufficient and meets requirements established by MMER.

A water sampling program will be developed prior to construction and operation activities commencing and be included with the Development Plan. This will include sampling of the water stations established by Gemtec, water being discharged into the environment, and in the Town of Ming's Bight water supply.

4.4.4.3 Potential Acid Rock Drainage (ARD) Testing

Anaconda has collected 20 specimens from The Project core samples taken throughout the deposit drilling program for Acid Rock Drainage (ARD) test work. These specimens were submitted to RPC Science and Engineering for analysis. The results of the ARD test work are listed in Table 10. The grade and ore/waste designation of each sample can be found in Table 11.

Table 10 – The Project Acid Rock Drainage Test Results

Client ID	Paste pH	Total Sulfur	Acid Production Potential	Neutralizing Potential pH 8.3	Net NP pH 8.3	NP/AP
		%	Kg CaCO ₃ /tonne			
AE-ARD-001	9.3	0.007	0.2	75.0	74.8	343
AE-ARD-002	8.9	0.151	4.7	71.0	66.3	15.0
AE-ARD-003	9.0	0.352	11.0	83.9	72.9	7.6
AE-ARD-004	9.2	0.077	2.4	17.0	14.6	7.1
AE-ARD-005	8.9	6.800	213	71.8	-141	0.3
AE-ARD-006	9.4	0.023	0.7	76.8	76.1	107
AE-ARD-007	9.3	0.075	2.3	91.4	89.1	39.0
AE-ARD-008	9.2	0.018	0.6	47.0	46.4	83.6
AE-ARD-009	9.0	1.610	50.3	74.7	24.4	1.5
AE-ARD-010	8.8	0.064	2.0	79.1	77.1	39.5
AE-ARD-011	9.3	0.085	2.7	94.7	92.0	35.6
AE-ARD-012	9.3	0.060	1.9	96.8	95.0	51.6
AE-ARD-013	9.2	0.158	4.9	10.7	5.8	2.2
AE-ARD-014	9.4	0.011	0.3	104	103	301
AE-ARD-015	9.0	0.229	7.2	42.2	35.0	5.9
AE-ARD-016	9.7	0.035	1.1	37.6	36.5	34.4
AE-ARD-017	8.9	0.134	4.2	77.2	73.0	18.4
AE-ARD-018	9.2	0.072	2.3	75.8	73.6	33.7
AE-ARD-019	9.1	0.021	0.7	16.2	15.5	24.6
AE-ARD-020	9.0	0.077	2.4	55.6	53.2	23.1

Table 11 - Grade Values and Waste/Ore Designation for The Project ARD Samples

Sample	Grade [g/t Au]	Waste/Ore (Cut-Off Grade of 0.8 g/t Au)
AE-ARD-001	0.008	Waste
AE-ARD-002	0.141	Waste
AE-ARD-003	0.213	Waste
AE-ARD-004	0.026	Waste
AE-ARD-005	5.617	Ore
AE-ARD-006	<0.005	Waste
AE-ARD-007	0.006	Waste
AE-ARD-008	<0.005	Waste
AE-ARD-009	3.990	Ore
AE-ARD-010	0.055	Waste
AE-ARD-011	0.123	Waste
AE-ARD-012	0.012	Waste
AE-ARD-013	<0.005	Waste
AE-ARD-014	0.029	Waste
AE-ARD-015	0.816	Ore
AE-ARD-016	0.010	Waste
AE-ARD-017	0.018	Waste
AE-ARD-018	0.266	Waste
AE-ARD-019	<0.005	Waste
AE-ARD-020	0.017	Waste

Of the 20 samples, 18 were found to have a positive Net Neutralizing Potential value, indicating that they are not acid producing samples. Of the submitted samples, three were found to be ore material, and 17 were found to be waste material.

One of the samples had a negative Net Neutralizing Potential value (AE-ARD-005), indicating that the sample was potentially acid producing, and one of the samples (Ae-ARD-009) resulted in a classification of ‘uncertain’. These two samples (potentially acid producing and ‘uncertain’) were both determined to be ore samples, as they returned Fire Assay grade results of 5.617 mg/kg Au and 3.990 mg/kg Au, respectively. The cut-off grade for The Project is to be 0.8 g/t Au (mg/kg Au), much lower than 3.990 mg/kg Au which returned an ARD test result of ‘uncertain’. As well, an ore sample (AE-ARD-015) that had a grade of 0.816 g/t Au was determined to be not acid generating. It is expected that all material remaining on the Argyle site (waste material and lost ore) will be non-acid generating. Based on the test results, the waste material has, on average, a much higher neutralizing potential than acid producing potential. The amount of ore loss is expected to be minimal as Anaconda has implemented numerous technological advancements in ore monitoring, including GPS systems on the mucking equipment and blast movement monitoring technology.

Operations at The Project will minimize the stockpiling of ore materials on site before they are transported to the ore pad at the Pine Cove Mill (maximum storage capacity of 20,000 t). Although it is not anticipated that the ore from The Project is acid generating, the material will be stockpiled on an impervious pad until it is transported to Pine Cove for processing. A ditch will surround the impervious pad to direct and control surface run-off from the stockpile into the ditching network, and subsequently into a collection or settlement pond. As described in Section 4.3.3.1, the ditching network and collection ponds will prevent any run-off from leaving the site. Samples from this collection ditch (and subsequent settlement pond) will be collected and tested weekly, or as required, to ensure that the water quality at Argyle remains within the regulatory guidelines.

The resulting tailings material produced from mill processing will be deposited in the already-permitted Pine Cove In-Pit Tailings Facility, using a sub-aqueous disposal method. The approved In-Pit Tailings Facility has a tailings capacity of 14 years, and creates no additional surface disturbance or footprint, as opposed to an earthen facility at surface. The sub-aqueous disposal process will mitigate any adverse affects from any potential acid producing material that may be found at The Project. The water quality and environmental conditions surrounding the in-pit tailings facility will be monitored regularly to ensure no variance in conditions occur when depositing the Argyle tailings material.

Once mining activities are completed, the pits will be allowed to flood, submerging the walls in groundwater. Although the west pit will be backfilled with waste material (as outlined in Section 4.4.1.1), it is assumed that the ground water will fill the empty voids in the backfill material, submerging the waste rock and pit walls in water.

Gemtec is currently completing a third-party study on the ARD testing results to further understand the geochemistry of the material at The Project. The report and recommendations will be included with the submission of the Development Plan.

4.4.4.4 Open Pit Closure and Reclamation

The development at The Project will include two open pits, as shown in Figure 5. For final rehabilitation and closure, the West Pit will be backfilled with waste material from the East Pit mining operation, and the east pit will be allowed to flood, subsequently draining into the natural environment. The haul road/ramp in the pit will be left in place, barricaded by a 1 m safety berm blocking the ramp entrance into the pit, to allow egress for persons or animals that may fall into flooded open pit. It is anticipated that the East Pit will overflow at 135 m elevation. It is assumed that the West Pit, although backfilled, will also flood with water filling the voids between the backfilled waste rock.

During mining operations, large rocks (waste rock in the magnitude of 1m-2m) excavated from the pit and dumps will be collected and hauled to the perimeter of the open pit above the final flooded pit water surface. The rocks will then be placed along the top of these sections to form a protective barrier to prevent people and vehicles from travelling directly over the top of the slope. The minimum distance from the berm to the pit rim is 6 m, which is in line with Occupation Health and Safety's expectations. Signs warning people of the steep slopes will also be erected at intervals ranging from 15 m to 25 m along the berm. Each sign will state; "CAUTION – OPEN HOLE – ABRUPT DROP AHEAD". The locations of the signage will be finalized for the Closure Plan submission. See Figure 15 for the berm locations relative to the pit. The red line represents the location of the closure berm around the Argyle East Pit, and the brown hatched area represents the backfilled West Pit.

Signage will also be posted around the site so that if someone inadvertently enters the site, signs will be visible to alert that person that there are hazards presents. Wording on the signage will be approved by Department of Natural Resources (DNR) but is expected to say 'Danger – No Trespassing: Argyle Mine Closed'. Signage will be sized to be visible and meet all posted signage requirements. Detailed drawings showing the location of the posted signage will be included with the Closure Plan submission to DNR.

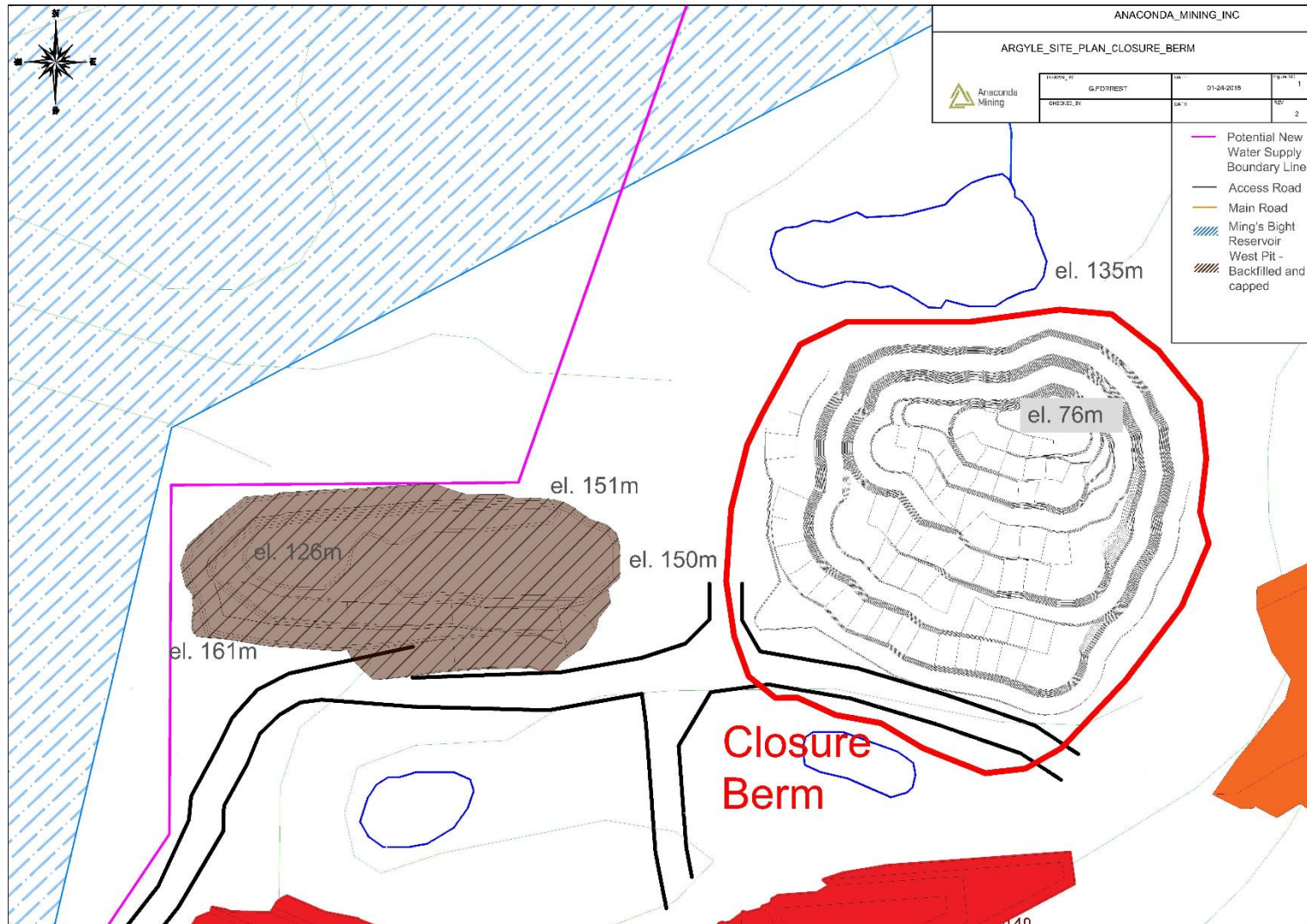

Figure 15 - Argyle Open Pit Closure Measures

4.4.5 Project Operation Considered

Consideration has been given to alternative options regarding the proposed project. This has included various stockpile locations, design parameters, orientations, Final Discharge Point location, as well as various open pit designs. These locations and designs have been generally accepted based on the topography in the area in addition to water body locations and existing accesses. The interest of the public (Town of Ming’s Bight and area residents) has also been taken into consideration when determining mitigation methods for noise, vibrations, dust, air quality, and water management.

4.5 Occupations

The Project is scheduled to commence as operations at Stog’er Tight and Pine Cove come to an end. It is expected that there will be a transfer of existing personnel, specifically in technical and mining related fields, for Anaconda. It is also anticipated that the contractors (Guy J. Bailey and NFLD Hard-Rok) transfer the existing personnel they have on the other projects to The Argyle Project. In addition, all current employees working at the Pine Cove Milling facility and administration would continue their employment to support The Project. This would include approximately 40 employees.

The anticipated occupations and personnel requirements directly related to The Project are listed in Table 12.

Table 12 - List of Direct Occupations and Quantity for the Construction and Operation Phases

Construction and Operations Phases		
Occupation	Quantity	National Occupational Classification
Health & Safety Supervisor	1	2263
Mine Superintendent	1	0811
Site Supervisor	1	7205
Geologist	2	2113
Planner/Engineer	1	2143
Surveyor	1	2154
Heavy Equipment Operators	3	7521
Truck Drivers	5	7521
Heavy Equipment Mechanics	4	7312
Pit Operations Foreman	1	7302
Labourer/Workers	2	7611
Driller	2	7372
Blaster	1	7372
Total	25	

It is anticipated that all occupations be filled with employees already employed by either Anaconda, Guy J. Bailey, or NFLD Hard-Rok.

As the mining operation approaches and achieves full production, The Project will continue to employ approximately 65 employees (25 directly and 40 indirectly).

Anaconda has recently developed a Women’s Employment Plan (WEP) for the Stog’er Tight Mine Expansion, another mine included in Anaconda’s Point Rousse Project. This WEP will continue to be used for Anaconda’s

future mines and projects and forms the basis for the Argyle WEP. Based on the planned sequence of operations between Pine Cove Mine, Stog’er Tight, and Argyle, it is anticipated that the same workforce will be used for each operation, indicating that there will not likely be any required hiring processes. However, if the need of additional employees arises, the WEP will be referenced and implemented. The WEP for Argyle is attached in Appendix D.

4.6 Project Related Documents

Anaconda has participated in two Ming’s Bight Town Council meetings over the past year to provide updates and information regarding Anaconda’s activity and operations in the area. This provided a forum for two-way communication about The Project, both to provide information and solicit any comments or concerns from the public and stakeholders.

Anaconda maintains regular informal communication with the Town of Ming’s Bight through telephone and in-person conversations, sharing information via e-mail and verbally.

Anaconda has consulted with the Town of Ming’s Bight (meeting notes attached in Appendix C), and with provincial government agencies, as well. All consultations are summarized in Table 13.

Table 13 - Summary of Regulatory Body Consultations Regarding The Project

Regulatory Body	Date	Consultation Details
Town of Ming’s Bight	Nov 28, 2016	Discussed exploration activities at Argyle, working near the Ming’s Bight water supply and the onus being on Anaconda to ensure environmental compliance
Town of Ming’s Bight	Dec 4, 2017	Discussed Stog’er Tight operations, Argyle Exploration and EA registration, water testing results being made available to the Town of Ming’s Bight, safety at Stog’er Tight and Argyle, and future mining operations in the area
DNR, EA, Water Resources, Pollution Prevention	Feb 16, 2018	Brief overview presentation of Argyle with the agencies and discussed potential concerns regarding the project. These concerns will be addressed and implemented within the EA document submission.

All other relevant documents to The Project are attached as Appendices to this report.

5 Approval of the Undertaking

The following is a list of permits, licences and approvals which are likely required for this project.

Table 14 - Projected permits, Authorizations and Approvals for The Project

Permit, Authorization or Approval	Activity Requiring Compliance	Government Agency	Status
Department of Natural Resources			
Mining Lease	Mining	Mineral Lands Division	Planned
Surface Lease	Mining	Mineral Lands Division	Planned
Application for Exploration Approval	Drilling and Trenching	Mineral Lands Division	Issued
Notice for Planned Mine	Mining	Mineral Development Division	Planned
Development and Operational Plan	General	Mineral Development Division	Planned
Reclamation and Closure Plan	General	Mineral Development Division	Planned
Department of Municipal Affairs and Environment			
Release from Environmental Registration	General	Environmental Assessment Division	Planned
Environmental Approval of Culverts	Road Construction	Water Resource Management Division	Planned
Permit to Alter a Body of Water	Water Discharging	Water Resource Management Division	Planned
Certificate of Approval for Site Drainage	Water Run-off from Site	Water Resource Management Division	Planned
Water Use Authorization	General Water Use	Water Resource Management Division	Planned
Development and Operational Plan	General	Mineral Development Division	Planned
Reclamation and Closure Plan	General	Mineral Development Division	Planned
Environmental Protection Plan	General	Pollution Prevention Division	In-House Document
Emergency Response Plan	General	Pollution Prevention Division	In-House Document
Environmental Effects Monitoring Plan	Effluent Discharge	Pollution Prevention Division	In-House Document
Department of Fisheries and Land Resources			
Cutting Permit	Tree Cutting	Forestry Services Branch	Planned
Operating Permit	General	Forestry Services Branch	Planned

6 Schedule

Table 15, below, illustrates the anticipated project schedule. This schedule was developed based on the requirement of throughput for the Pine Cove Mill. As Pine Cove and Stog'er Tight operations finish, a need for ore throughput at Pine Cove Mill will arise. The Project is within 6.5 km of the Pine Cove Mill and has an NI 43-101 compliant resource, making it Anaconda's next viable resource for operation.

7 Funding

The capital and operating costs for the Argyle Project are estimated at \$1.71M and \$23.7M, respectively. The funding for the project will be provided by Anaconda Mining Inc.

8 Submission

Date

Name

Appendix A

Environmental Baseline Studies



**Preliminary Baseline Studies
Anaconda Mining Inc.'s Argyle Property**

Baie Verte, NL
January 30, 2018

Prepared for Anaconda Mining Inc.
Project No. 80016.09



January 30, 2018

File: 80016.09 – R01

Anaconda Mining Inc.
238 Highway 410
Baie Verte, NL
A0K 1B0

Attention: Gordana Slepcev, P.Eng., M.Sc.
Chief Operating Officer

**Re: Preliminary Baseline Studies Final Report, Anaconda Mining Inc.'s Argyle Property,
near Ming's Bight, Newfoundland and Labrador**

Please find enclosed our Preliminary Baseline Studies Final Report in support of the development of Anaconda Mining Inc.'s proposed Argyle property located near Ming's Bight, Newfoundland and Labrador. The field components relative to this report were conducted in July and August, 2017.

If you have any questions please contact the undersigned at your convenience.

Sincerely,



Darrol Rice, B.Tech. (Env), P.Tech., EP, PMP
Senior Project Manager

Enclosures:

**Preliminary Baseline Studies
Argyle Property near Ming’s Bight,
Newfoundland & Labrador**

Table of Contents

Table of Contents.....	iii
Appendices	iv
List of Figures	iv
List of Tables	iv
Executive Summary	vi
1.0 Introduction	1
2.0 Scope of Work and Methodology.....	3
2.1 Historic Resource Assessment	5
2.2 Wetland Assessment	5
2.2.1 Methodology	5
2.2.2 Wetland Assessment Results.....	6
2.3 Vegetation and Plant Survey	9
2.3.1 Ecoregion Description.....	9
2.3.2 Vegetation Survey Results.....	11
2.3.3 Non-Vascular Species at Risk.....	12
2.4 Wildlife and Fauna Survey	14
2.4.1 Methodology	14
2.4.2 Breeding Bird Survey	14
2.4.3 Breeding Bird Survey Results	15
2.4.4 Other Wildlife Surveys	19
2.5 Aquatic Habitat Assessment.....	22
2.5.1 Wetland and Surface Water Features	22
2.5.2 Wetland 1 and Unnamed Tributary	22
2.6 Surface Water Quality Monitoring and Sampling.....	22
2.6.1 Surface Water Quality Monitoring and Sampling Results	23
3.0 Conclusions.....	24
4.0 Closure.....	25
5.0 References.....	26

**Preliminary Baseline Studies
Argyle Property near Ming’s Bight,
Newfoundland & Labrador**

Appendices

- A Wetland Photos
- B Habitat Photos
- C ACCDC Info
- D Plant Inventory
- E Rare Plant Photos
- F Rare Plant Locations (Common Wintergreen)
- G Bird Point Survey Data
- H Analytical Data
- I Laboratory Certificates of Analysis

List of Figures

Figure 1: Site Location Plan	2
Figure 2: Limits of the Mine Development Area (MDA).....	4
Figure 3: Wetland Locations.....	8
Figure 4: Rare Flora Locations.....	13
Figure 5: Bird Survey and Surface Water Sampling Locations	21

List of Tables

Table 1: Field Study Schedule	3
Table 2: Summary of Delineated Wetlands and Functional Assessments	6
Table 3: Bird Species recorded within the MDA - July 6, 2017	16
Table 4: Summary of Birds Species at Risk	18
Table 5: Summary of Wildlife Species at Risk	20
Table 6: Surface Water Quality Monitoring and Sampling Locations	23
Table 7: Field Water Quality Monitoring Results.....	23

**Preliminary Baseline Studies
Argyle Property near Ming's Bight,
Newfoundland & Labrador**

Executive Summary

Anaconda Mining Inc. (Anaconda) is proposing to develop a new gold mine on their Argyle Property (the Project) located near Ming's Bight, Newfoundland and Labrador (Figure 1). The Project is located approximately 10 kilometres (km) southwest of the community of Ming's Bight and approximately 10 km from their existing Pine Cove Mine and Mill operation.

GEMTEC Consulting Engineers and Scientists (GEMTEC) was retained by Anaconda to complete baseline ecological studies at this property. The field based investigations were carried out during the summer, 2017. Baseline studies included:

- Historic Resources Assessment;
- Wetlands delineation;
- A vegetation and flora survey;
- A wildlife and fauna survey;
- An aquatic habitat assessment; and
- A water quality sampling program.

The studies were completed to obtain preliminary information on the applicable Valued Ecosystem Components (VECs) located within the Mine Development Area (MDA) and this report provides a summary of those findings.

GEMTEC engaged Mr. Derrick Mitchell, a biologist with Boreal Environmental, to assist in planning and executing the ecological baseline studies in July and August, 2017.

Based on the findings of these studies, the following conclusions are presented:

- The Project is located within an area having low historic resource potential;
- A total of 6 wetlands were identified within the proposed MDA. The delineated wetlands ranged in size from approximately 0.03 hectares to 4.7 hectares; however, several wetlands extended beyond the MDA. In general, the encountered wetlands have high wetland functionality in native plant habitat;
- The concentration of aluminum (102 µg/L) in surface water sample SW-1 exceeded the Canadian Water Quality Guidelines for the Protection of Freshwater Aquatic Life (CCME FWAL) limit of 100 µg/L. All other total metals and general chemistry parameters were below laboratory detection limits or below the CCME FWAL criteria;

- One rare vascular flora species was identified within the MDA: Common wintergreen (*Chimaphila umbellata*);
- There is little or no viable fish habitat in the MDA; therefore the potential for fish to be present is very low; and
- A total of 20 bird species comprising of 89 individuals were documented during the Breeding Bird Survey. None of the species recorded are considered Species at Risk (SAR).

The statements made in this Executive Summary are intended to be read in conjunction with the entire body of this report, including all appendices.

This document presents the findings of the preliminary baseline studies and no comment is made with respect to the development, construction or operation phases of the proposed Project.

1.0 Introduction

Anaconda Mining Inc. (Anaconda) is proposing to develop a new gold mine on their Argyle Property (the Project) located near Ming's Bight, Newfoundland and Labrador (Figure 1). The Project is located approximately 10 kilometres (km) southwest of the community of Ming's Bight and approximately 10 km by road from their existing Pine Cove Mine and Mill operation.

GEMTEC's current understanding of the Project is presented as follows:

- Anaconda intends to commence mining activities within approximately two years (2019);
- Mining operations will be open pit;
- Ore will be transported and processed at Anaconda's existing Pine Cove mill;
- Based on ore processing taking place at Anaconda's existing Pine Cove mill, there will be no tailings generated at the Property. Tailings will be disposed of at Anaconda's existing Pine Cove facilities;
- The Project is in close proximity to Ming's Bight Protected Public Water Supply Area (PPWSA). A portion of an existing gravel access road runs through the PPWSA. Anaconda has indicated that no mining will take place directly in the watershed; however it is likely that regulator consultation be required to determine what studies, if any, are required. No studies associated with the PPWSA are included in this report;
- No existing waterbodies will be removed as the project footprint is developed;
- There will be waste rock generated from the mining operations which will require permanent surface dumps, and ore stockpiling areas on-site;
- Anaconda is planning to submit a Project Registration during winter 2018;
- It is understood that no federal environmental assessment review is required; and
- We understand that while an initial resource has been defined at Argyle, the Project scope and description has not been finalized and could possibly be phased to allow for early ore extraction and transport to the existing mill. Further or additional studies may be required as the proposed Project advances.

This Project will also include the transportation (truck haulage) of ore from the site to the existing Pine Cove Mill. Additionally, if the tailings from the processing of ore material from the Argyle deposit need to be deposited somewhere other than in the existing permitted tailings management facility (TMF), this change will likely be subject to a more extensive Environmental Assessment (EA) and permitting process. These potential requirements should be considered as the planning and design of the Project are advanced.

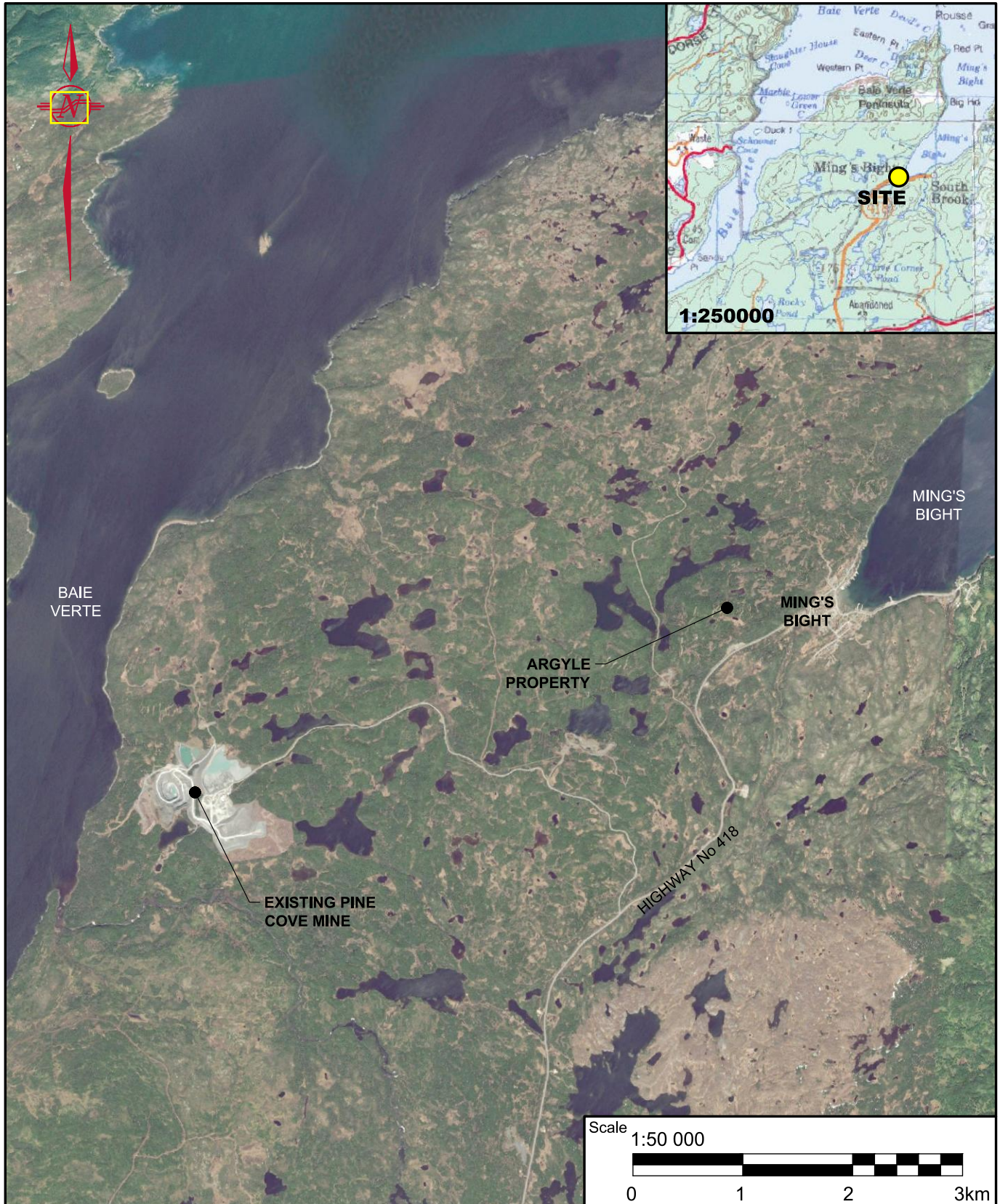

Project		Drawing		
ARGYLE BASELINE STUDIES		SITE LOCATION PLAN		
Drawn By	Date	File No.	Drawing No.	Revision No.
CHG	JAN 2018	800160901	FIGURE 1	0



GEMTEC
CONSULTING ENGINEERS
AND SCIENTISTS

N:\DRAWINGS\80000\80016_09\800160901.DWG

2.0 Scope of Work and Methodology

GEMTEC was retained by Anaconda to carry out preliminary baseline studies in support of the Project development. Results of these studies will also inform a Registration document for the Project that will be submitted to the Newfoundland EA Division. Studies included:

- Historic Resources Assessment;
- Wetlands delineation and assessment;
- A vegetation and flora survey;
- A wildlife and fauna survey;
- A aquatic habitat visual assessment; and
- A surface water quality sampling program.

GEMTEC engaged Mr. Derrick Mitchell, a biologist with Boreal Environmental (Boreal), to assist in planning and executing the ecological component studies within the proposed mine development area (MDA) of the Project (Figure 2). GEMTEC and Boreal were on site in July and August, 2017. Due to the seasonal characteristics of several Value Ecosystem Components (VEC), two trips were required to collect all relevant information (Table 1). Details of each study are discussed below.

Table 1: Field Study Schedule

Site Visit Date	Field Component
July 5 to 7, 2017	<ul style="list-style-type: none"> • Breeding Bird Survey, Fauna Survey and Wetland Assessment, Water Quality Monitoring and Sampling, Aquatic Habitat Visual Inspection
August 10 to 12, 2017	<ul style="list-style-type: none"> • Fauna Survey and Wetland Assessment



The site-specific field study program was developed by referencing the standard methods outlined by:

- Bird Studies Canada (BSC); and
- Army Corps of Engineers in the Regional Supplement to the Corps of Engineers Wetland Delineation Manual: North Central and Northeast Region.

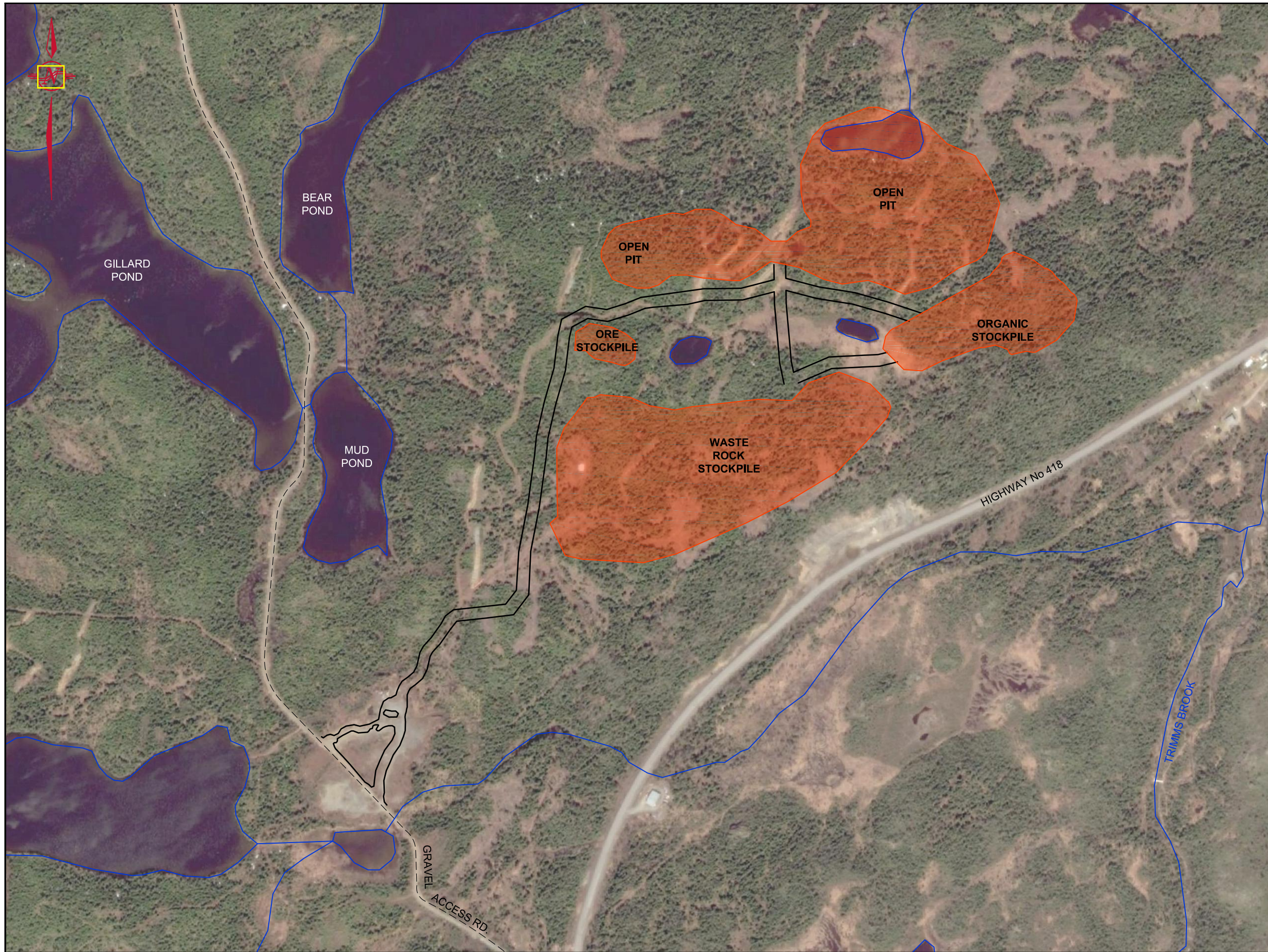
These documents were used as guidelines to refine a field reconnaissance program to the site-specific conditions and to the scope of work for the proposed Project, while obtaining the required information for an EA Registration document.



Legend

-  WATERCOURSE
-  PROPOSED ROAD
-  PROPOSED MINE DEVELOPMENT AREA

Note

1. THIS DRAWING IS A SCHEMATIC REPRESENTATION. SIZES, LOCATIONS AND DIMENSIONS ARE APPROXIMATE.
2. AERIAL PHOTOGRAPH FROM 2015. SOURCE GOOGLE EARTH.

Drawn By	CHG	Checked By	DR
Calculations By	---	Checked By	---

Date: JANUARY 2018

Project: ARGYLE BASELINE STUDIES

Drawing: PROPOSED MINE DEVELOPMENT AREA

Scale: 1:5000

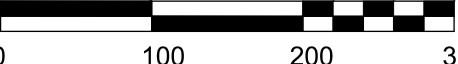

File No.	Drawing	Revision No.
800160901	FIGURE 2	0

 **GEMTEC**
CONSULTING ENGINEERS AND SCIENTISTS

N:\DRAWINGS\80000\80016_09\800160901.DWG

2.1 Historic Resource Assessment

GEMTEC consulted with a Provincial archaeologist to determine if the site/location has the potential for culturally significant sites to be located within or nearby or if there are any archaeological sites in the area. The Project site is considered to be situated in an area of low archaeological potential and as such there are no concerns.

2.2 Wetland Assessment

A wetland assessment was conducted within the MDA and included:

- Boundary delineation of any wetlands encountered; and
- Identification of wetland characteristics of each wetland.

2.2.1 Methodology

The boundaries and characteristics of each wetland encountered during the 2017 field study program were identified. Wetland boundaries outside of the MDA were delineated using aerial photo interpretation techniques and it should be noted that photo interpreted boundaries are approximate and are used to illustrate the extent of wetlands potentially affected by the development of the mine.

There is no specific protocol or methodology for delineating wetlands in Newfoundland and Labrador. There is, however, an accepted industry standard described by the Army Corps of Engineers in the *Regional Supplement to the Corps of Engineers Wetland Delineation Manual: Northcentral and Northeast Region*. This protocol is used for wetland boundary determination throughout North America and more regionally in the Maritime provinces.

The wetland delineation was conducted using a modified version of the methodology outlined in the Corps of Engineers, *Wetlands Delineation Manual* (Environmental Laboratory 1987). The Corp of Engineers methodology typically assesses three parameters; vegetation, hydrology and soils. Only two parameters, vegetation and hydrology, were used in this assessment, with the rationale being that hydric soils are likely to be present if hydrophytic vegetation and saturated conditions exist.

Wetland conditions were identified using the following criteria:

- A majority of dominant vegetation species are wetland associated species; and
- Hydrologic conditions exist that result in periods of flooding, ponding, or saturation during the growing season.

The location of wetland boundaries inside the MDA were recorded using a Trimble Nomad field computer and Garmin GLO GPS receiver with a stated accuracy of +/- 3 m.

The Canadian Wetland Classification System was used to classify wetlands as either fen, swamp and/or shallow water (CWCS 1997).

2.2.2 Wetland Assessment Results

A total of six wetlands were identified within the MDA during the field studies program. The delineated wetlands (WL) ranged in size from approximately 0.03 hectares (ha) (WL5) to 4.7 ha (WL6). However, several wetlands, WL1 and WL6, continued beyond the boundary of the MDA (Table 2). Wetland locations are depicted on Figure 3 and site photos are presented in Appendix A.

In general, WLS 3, 4, 5, and 6 are topographically defined and located in a basin or at the toe of slope landscape position. Only WL 1 has a channel with flowing surface water which discharges from the wetland down a steep gradient. WL2 and WL6 are headwater wetlands and provide the source water for watercourses that discharge from them. A watercourse that is part of the provincial inventory is shown to be discharging from WL6, while the one discharging from WL 2 is unmapped. The wetlands and hydrological connections are presented in Figure 3.

Table 2: Summary of Delineated Wetlands and Functional Assessments

Wetland ID	Wetland Size within MDA (hectares)	Wetland Classification and Characteristics
1	2.0	<p>WL1 is a wetland complex made up of shallow water basin, riparian swamp and drainageway swamp. It is bisected by an access road at the outlet of the shallow water portion of WL1. WL1 drains via an unmapped watercourse towards Route 418 south of the MDA. WL1 is fed by an unnamed pond located to the west (Figure 3).</p> <p>The portion east of the access road is riparian forest dominated by Green alder (<i>Alnus viridis</i>) and Squashberry (<i>Viburnum edule</i>).</p> <p>The western portion of the wetland is a sparsely vegetated shallow water wetland with a cobble/gravel substrate. Shoreline and aquatic vegetation consists of Water lobelia (<i>Lobelia dortmanna</i>), Roundleaf sundew (<i>Drosera rotundifolia</i>), Beaked sedge (<i>Carex rostrata</i>), Slender sedge (<i>Carex lasiocarpa</i>) and Blue-joint reedgrass (<i>Calamagrostis canadensis</i>).</p> <p>The drainageway swamp component is dominated by Yellow sedge (<i>Carex flava</i>), Star sedge (<i>Carex echinata</i>), Green alder, Balsam fir (<i>Abies balsamea</i>), and Black spruce (<i>Picea mariana</i>) (Photo 1 and 2)</p>
2	0.3	<p>WL2 is a sloping spring fen dominated by star sedge (<i>Carex echinata</i>), tawny cotton-grass (<i>Eriophorum virginicum</i>), deergrass (<i>Trichophorum cespitosum</i>), and alpine cotton-grass (<i>Trichophorum alpinum</i>) (Photo 3 and 4).</p> <p>WL2 has no obvious inlet and is likely influenced by groundwater discharging from a steep slope transition occurring at the middle to upper slope landscape position. A small intermittent watercourse discharges from the southern end of WL2 and down a steep slope.</p>
3	1.6	<p>WL3 is a minerotrophic sedge dominated basin fen with two open water features. These open features have no inlet or channelized</p>

Wetland ID	Wetland Size within MDA (hectares)	Wetland Classification and Characteristics
		<p>outlet. WL3 drains via a diffuse seep at the southern end of the wetland. Groundwater is likely the primary source of water based on the pH of the open water feature, i.e., greater than 7.</p> <p>WL3 is dominated by star sedge (<i>Carex echinata</i>), Tawny cotton-grass (<i>Eriophorum virginicum</i>), Deergrass (<i>Trichophorum cespitosum</i>), and Alpine cotton-grass (<i>Trichophorum alpinum</i>) (Photo 5 and 6).</p>
4	0.08	<p>WL4 is a small drainageway swamp dominated by Shore sedge (<i>Carex lenticularis</i>), Purple avens (<i>Geum rivale</i>), Squashberry and Alderleaf buckthorn (<i>Rhamnus alnifolia</i>) (Photo 7 and 8).</p> <p>WL4 has no inlet and no obvious outlet. There may be an interaction with the shallow groundwater aquifer that discharges to WL6 downslope.</p>
5	0.03	<p>WL5 is a very small basin swamp dominated by Alderleaf buckthorn, Golden groundsel (<i>Packera aurea</i>), and Bristly-stalked sedge (<i>Carex leptalea</i>) (Photo 9).</p>
6	4.7	<p>WL6 is the largest wetland encountered within the MDA but the majority of WL6 lies outside of the MDA. WL 6 is a minerotrophic sedge dominated basin fen with a relatively large open water feature. WL6 also receives groundwater as its primary source of water based on the pH of the open water, i.e., greater than 7.</p> <p>WL 6 is dominated by slender sedge, bog buckbean (<i>Menyanthes trifoliata</i>) and alpine cotton-grass (Photo 10 and 11 in Appendix A)</p>

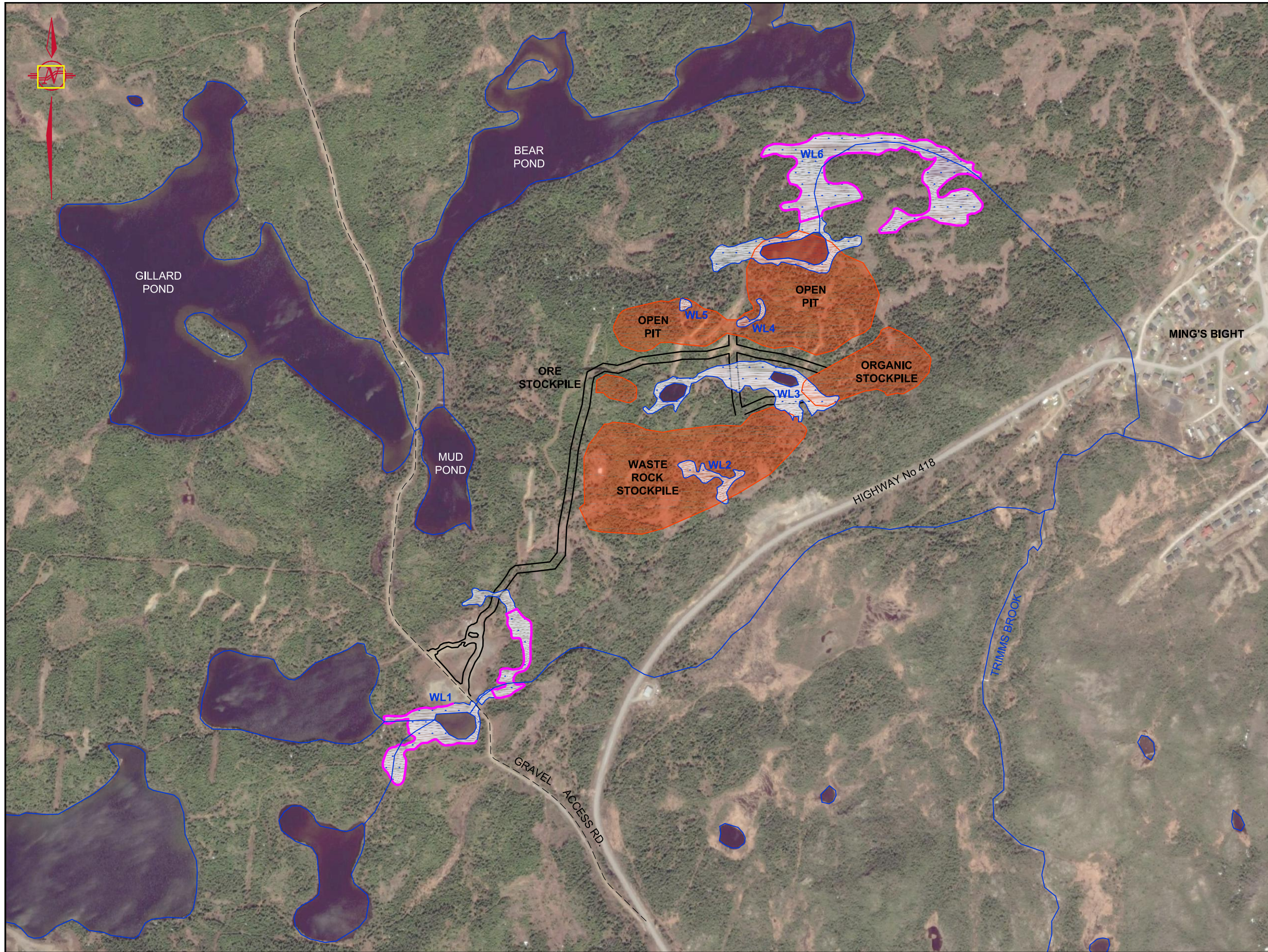

Legend

- WATERCOURSE
- PROPOSED ROAD
- INTERPRETED WETLAND
- PROPOSED MINE DEVELOPMENT AREA
- WETLANDS

Note

- THIS DRAWING IS A SCHEMATIC REPRESENTATION. SIZES, LOCATIONS AND DIMENSIONS ARE APPROXIMATE.
- AERIAL PHOTOGRAPH FROM 2015. SOURCE GOOGLE EARTH.

Drawn By	CHG	Checked By	DR
Calculations By	---	Checked By	----

Date: JANUARY 2018

Project: ARGYLE BASELINE STUDIES

Drawing: WETLAND DELINEATIONS

Scale: 1:7500

File No.	Drawing	Revision No.
800160901	FIGURE 3	0

GEMTEC
CONSULTING ENGINEERS AND SCIENTISTS

N:\DRAWINGS\80000\80016_09\800160901.DWG

2.3 Vegetation and Plant Survey

2.3.1 Ecoregion Description

Although the MDA lies in a transitional area between the North Shore Ecoregion and the North Central Subregion, the MDA displays vegetative characteristics consistent with the North Shore Ecoregion.

The North Shore Ecoregion represents a narrow coastal zone extending from Bonavista Bay to the Baie Verte Peninsula. The summers are relatively dry and warm and soil moisture is low during this time. In general, black spruce and balsam fir forests are the most prevalent forest type forming a continuous forest cover except where barrens dominate on the coastal headlands. Midslopes are dominated by the Hylocomium-Balsam Fir type, or by the Black Spruce-Feathermoss type dry outcrops and steep slopes with a south aspect. Trembling Aspen rarely forms pure stands except on richer warmer microsites. The landforms are similar to those of the Central Newfoundland Subregion and are characterized by undulating topography (Fisheries and Land Resources 2017).

Forested Areas

The MDA is dominated by Hylocomium-Balsam Fir forest type on mesic sites and the Black Spruce-Feathermoss type on drier sites. Forest types are in various stages of development based on the disturbance regime and specific site factors. Although there are some small remnant patches of old forest, most of the MDA was harvested over the past 30 years. More recent forest clearing has occurred as a result of exploration activities. Richer sites located in mid-slope or in terraced positions tend to be dominated by small stands of trembling aspen (*Populus tremuloides*). The understory of both coniferous forest types are dominated by bunchberry (*Cornus canadensis*), twinflower (*Linnaea borealis*), creeping snowberry (*Gaultheria hispidula*), and clinton lily (*Clintonia borealis*). Representative habitat photographs are provided in Appendix B, Photos 1 and 2.

Disturbed Areas

Many areas within the MDA have been disturbed by exploration activities and access trails. Cleared areas are dominated by early successional species including pearly everlasting (*Anaphalis margaritacea*), wild raspberry (*Rubus idaeus*), flat bunchberry, topped fragrant goldenrod (*Euthamia graminifolia*), fireweed (*Chamerion angustifolium*), and green alder. Representative photographs are provided in Appendix B, Photo 3.

Methodology

The scope of work carried out for the vegetation and flora survey within the MDA included:

- A desktop Species at Risk (SAR) Study;

- Identification of all encountered vascular vegetation within the MDA; and
- Identification of all encountered flora (vascular) within the MDA.

A desktop study for SAR and areas of concern was conducted prior to the site visit. The SAR screening was conducted by obtaining data from the Atlantic Canada Conservation Data Centre (ACCDC) and was limited to a 5 km radius of the MDA. This database search provided the following:

- Reported observations of rare and endangered flora;
- Expert Opinion Maps information to identify species that have not been reported but are expected, based upon estimates of habitat and wildlife distribution; and
- Locations of any Special Areas such as the following:
 - Managed areas with some level of protection;
 - Significant ecological areas of interest;
 - National Defense areas; and
 - First Nations areas.

The species listed within the ACCDC report were referenced to rankings outlined by the *Committee on the Status of Endangered Wildlife in Canada* (COSEWIC), the *Species at Risk Act* (SARA), and the *Newfoundland and Labrador Endangered Species Act* (NLESA). The ACCDC report, mapping and habitat comparison tables are attached as Appendix C.

SARA provides protection for flora species against extirpation, extinction or endangerment from human activities. Currently, only the species listed in Schedule 1 of SARA are protected federally. Provisions to protect and recover a species come into effect once it has been listed in Schedule 1 of SARA.

The NLESA provides another level of legislative protection for SAR. Different levels of protection are afforded for species listed within these acts depending on the species rarity ranking. All species identified ranking S1 or S2 by the ACCDC are considered rare for the purpose of this report.

The vegetation and flora surveys were conducted during multiple stages of the flowering season to ensure identification of both the early and late flowering plants. The field biologist (Derrick Mitchell) dedicated approximately 40 hours to the vegetation and plant survey on two separate site visits. The site was traversed on foot and focused on unique habitats (*i.e.*, rock outcrops, mature forest, watercourses and wetlands) in a random meandering fashion. In general, these habitats have an elevated potential for the occurrence of rare species. Consideration was given to the mature coniferous forest, the preferred habitat for boreal felt lichen (*Erioderma pedicellatum*), which is listed as a species of 'Special Concern' by both, COSEWIC and SARA, and 'Vulnerable' by the NLESA. Mountain holly fern (*Polystichum scopulinum*) was also listed in

the ACCDC report as potentially occurring in the region. This species is listed as 'Threatened' by both COSEWIC and SARA. The locations of all plants were recorded using a handheld GPS unit and photos were taken. An inventory of all plant species encountered was recorded during field studies.

2.3.2 Vegetation Survey Results

A complete inventory of plant species encountered within the MDA is presented in Appendix D. The locations of encountered rare flora are presented in Figure 4.

Common wintergreen (*Chimaphila umbellata*), an S2 plant species as per ACCDC, was the only rare plant species identified during field studies. This plant species tends to occur in small openings in crest of slope or hilltop landscape positions with a southern aspect. Naturally it occurs on dry (i.e., xeric) and thin soils in mature black spruce stands that have begun to break up due to old age or natural disturbances that have created small openings in the canopy (Photo 1 and 2 in Appendix E). In addition, field observations indicate that it is encouraged by low impact forest clearing activities in suitable habitat where the ground is not disturbed such as winter firewood harvesting and when there is snow pack.

Approximately 5,650 common wintergreen plants were identified within 100 different patches inside and outside of the MDA. Within the MDA, which includes the proposed road Right of Way (RoW), there were approximately 2,750 plants in 11 distinct patches identified. Some patches were distinct and separated from others, whereas other patches were clustered where suitable habitat was abundant. To ensure that the MDA and area immediately adjacent were not unique with respect to the abundance of common wintergreen, a control area that was predicted to have suitable habitat approximately 900 m from the MDA was surveyed (Figure 4). Immediately upon arrival at this site, approximately 200 individual plants in three patches were identified. Due to the number of plants identified in and outside of the MDA, common wintergreen is assumed to be regionally abundant. All locations of common wintergreen can be found in Appendix F.

Mountain holly fern were not found during the survey.

2.3.3 Non-Vascular Species at Risk

Boreal felt lichen, a SAR identified by the ACCDC as having the potential to occur in this region, was not found in the MDA. Boreal felt lichen prefers mature forest with an abundance of moisture-loving species such as *Sphagnum* moss species (i.e., mesic to hydric sites). Mature forested swamps are not present within the MDA and mature upland areas of Spruce / Fir tended to be located on dry hilltops and steep slopes with a southern aspect and thin soils. Understory vegetation in these stands tends to be sparse and the forest floor was blanketed with feather mosses (e.g., *Pleurozium schreberi* and *Hylocomium splendens*). The MDA tends to have a southern aspect and / or is located in a hilltop position which does not favour lichen development. The potential for Boreal felt lichen to occur in the MDA is low due to these site specific factors.

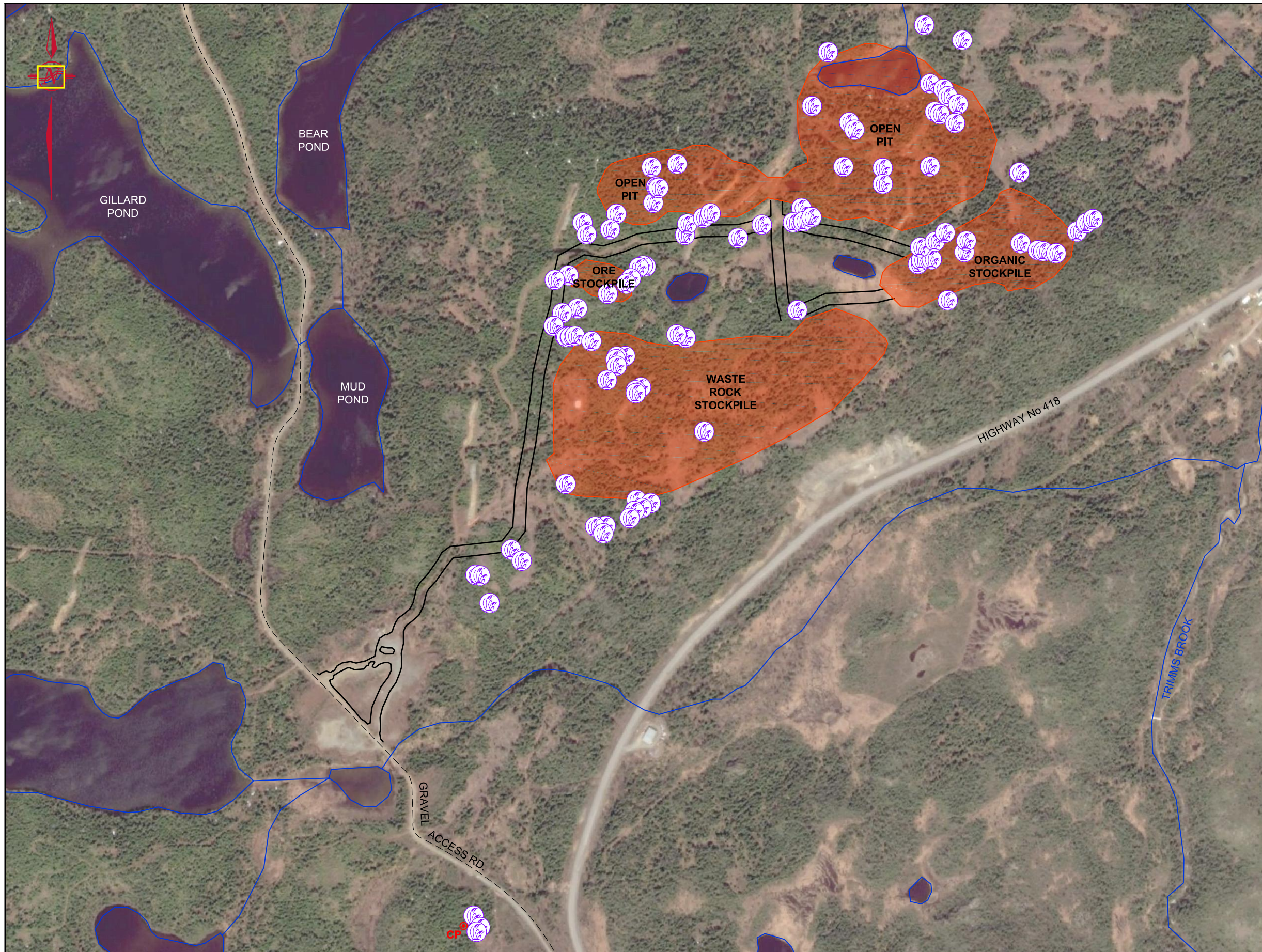

Legend

- CHIMAPHYLLA UMBELLATA (COMMON WINTERGREEN)
- CONTROL POINT
- WATERCOURSE
- PROPOSED ROAD
- PROPOSED MINE DEVELOPMENT AREA

Note
 1. THIS DRAWING IS A SCHEMATIC REPRESENTATION. SIZES, LOCATIONS AND DIMENSIONS ARE APPROXIMATE.
 2. AERIAL PHOTOGRAPH FROM 2015. SOURCE GOOGLE EARTH.

Drawn By CHG	Checked By DR
Calculations By ---	Checked By ---

Date
JANUARY 2018

Project
ARGYLE BASELINE STUDIES

Drawing
RARE FLORA LOCATIONS

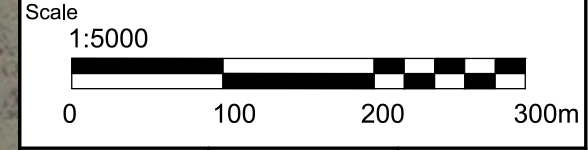

File No. 800160901	Drawing FIGURE 4	Revision No. 0
-----------------------	---------------------	-------------------

N:\DRAWINGS\80000\80016_09\800160901.DWG

2.4 Wildlife and Fauna Survey

A wildlife and fauna survey was conducted within the MDA and included:

- A desktop SAR Study;
- A breeding bird survey;
- General wildlife observations during field exercises; and
- Field survey for SAR (July and August).

The wildlife and fauna survey did not include the trapping, tracking or collection of any wildlife and / or specimens.

2.4.1 Methodology

SARA provides protection to fauna species against extirpation, extinction or endangerment from human activities. Currently, only the species listed in Schedule 1 of SARA are protected federally. Provisions to protect and recover a species come into effect once it has been listed in Schedule 1 of SARA. The federal *Migratory Birds Convention Act (MBCA)* provides overarching protection for individuals and populations of birds and their nests, including songbirds, waterfowl and seabirds, against harm or destruction. The *MBCA* and associated regulations are administered by ECCC through the Canadian Wildlife Service (CWS).

The following sections describe the field studies undertaken to identify wildlife and potential SAR and their habitat that may be present within the MDA.

2.4.2 Breeding Bird Survey

Breeding bird surveys were conducted as per the methods outlined by Bird Studies Canada. To ensure representation of habitat types, preliminary site selection for the bird point count locations were identified based on the following:

- Forest species composition; and
- Development stage within the MDA.

Aerial photography was used to determine the above mentioned during the planning stage and point locations were adjusted based on actual site conditions.

A single round of breeding bird surveys was conducted on the morning of July 6, 2017 from 05:35 - 07:25. Each point count location was surveyed for a period of 10 minutes. The breeding status of each species was determined using the criteria outlined by Bird Studies Canada. Data collected for each bird detected included: number, species, behavior, and location in relation to the survey point. Weather parameters (*i.e.*, wind speed, wind direction, sky condition and temperature) were also recorded at each point count location.

Species observed or heard singing in suitable nesting habitat were classified as possible breeders if they exhibited the following behaviours:

- Courtship behaviour between a male and female;
- Birds visiting a probable nest site;
- Birds displaying agitated behaviour; or
- Male and female observed together in suitable nesting habitat.

Species were confirmed as breeding if any of the following items or activities were observed:

- Nest building or adults carrying nesting material;
- Distraction display or injury feigning;
- Recently fledged young;
- Occupied nest located; or
- Adult observed carrying food or fecal sac for young.

Incidental bird observations / singing were also recorded in conjunction with wetland and flora field studies. This ensured that the bird species diversity within the MDA was captured.

2.4.3 Breeding Bird Survey Results

The ACCDC report and a summary table outlining the species ranking (Table C1) and a summary table of the preferred habitat for each ACCDC listed species (Table C2) are presented in Appendix C.

A total of 20 bird species comprising of 89 individual records were documented during the survey (Table 3) and the breeding bird survey locations are presented in Figure 5. The most numerous species recorded overall, in descending order, are:

- White-winged Crossbill (*Loxia leucoptera*);
- Fox Sparrow (*Passerella iliaca*);
- Northern Waterthrush (*Parkesia noveboracensis*);
- Ruby-crowned Kinglet (*Regulus calendula*);
- Yellow-rumped Warbler (*Setophaga coronate*); and
- Boreal Chickadee (*Poecile hudsonicus*).

The observed abundance of these species would be expected given the development stage and species composition of the area within the MDA as these species are characteristic of the forest

and wetland habitats that are found within the MDA. No bird SAR were recorded during the breeding bird surveys. Point data specific to bird locations are included in Appendix G.

No raptor nests were noted in the MDA but an Osprey, (*Pandion haliaetus*), was observed carrying a fish and displaying agitated behaviour several hundred meters north of the MDA.

Table 3: Bird Species recorded within the MDA - July 6, 2017

Common Name	Latin Name	S-Rank*	Highest breeding status†	Number Recorded
<i>Turdus migratorius</i>	American Robin	S5B,S5M	PO	4
<i>Picoides dorsalis</i>	American tree-toed Woodpecker	S5	PO	1
<i>Dendroica virens</i>	Black-throated Green Warbler	S5B,S5M	PO	2
<i>Vireo solitarius</i>	Blue-headed Vireo	S3B,SUM	PO	3
<i>Poecile hudsonicus</i>	Boreal Chickadee	S4	PO	5
<i>Junco hyemalis</i>	Dark-eyed Junco	S5	PO	1
<i>Picoides pubescens</i>	Downy Woodpecker	S4	PO	1
<i>Passerella iliaca</i>	Fox Sparrow	S5	PO	9
<i>Perisoreus canadensis</i>	Gray Jay	S5	CO	3
<i>Picoides villosus</i>	Hairy Woodpecker	S4	CO	3
<i>Catharus guttatus</i>	Hermit Thrush	S5B,S5M	PO	2
<i>Setophaga magnolia</i>	Magnolia Warbler	S4B,SUM	PO	4
<i>Parkesia noveboracensis</i>	Northern Waterthrush	S5B,S5M	CO	8
<i>Pandion haliaetus</i>	Osprey	S4, SUM	CO	1
<i>Regulus calendula</i>	Ruby-crowned Kinglet	S5	PO	6
<i>Catharus ustulatus</i>	Swainson's Thrush	S5B,S5M	PO	1
<i>Zonotrichia albicollis</i>	White-throated Sparrow	S5B,S5M	PO	4
<i>Loxia leucoptera</i>	White-winged Crossbill	S5	PO	21
<i>Empidonax flaviventris</i>	Yellow-bellied Flycatcher	S5B,S5M	PO	4
<i>Setophaga coronata</i>	Yellow-rumped Warbler	S5B,S5M	CO	6
Total				89
<p>† Breeding Status Codes: OB = observed PO = possible breeder PR = probable breeder CO = confirmed breeder</p>				

Table 4 summarizes the habitat requirements of SAR bird species identified by the ACCDC as potentially occurring within the MDA. Table 4 also indicates the likelihood of occurrence for these species based on field observations and observed habitat within the MDA.

Table 4: Summary of Birds Species at Risk

Species	Scientific Name	Habitat Summary	Habitat Present	Likelihood of Occurrence
Barrow's Goldeneye	<i>Bucephala islandica</i>	Data indicate that it breeds only in Canada with the only confirmed breeding records are from Quebec. Small numbers of this population winter in the Maritime Provinces and along the northern Atlantic coastline in the United States. In Quebec, the eastern population inhabits the balsam fir-white birch forest regions of the province. More specifically, birds appear to be restricted to small, high elevation lakes north of the St. Lawrence Estuary and Gulf. During the non-breeding season, the species spends time in the coastal waters of the Estuary and Gulf.	No	NA
Ivory Gull	<i>Pagophila eburnea</i>	In Canada, the species breeds exclusively in Nunavut. Wintering occasionally along the eastern coasts of Newfoundland and Labrador, particularly the Great Northern Peninsula of Newfoundland. Outside the breeding season, Ivory Gulls live near the edges of pack ice or drift ice.	No	NA
Red Crossbill	<i>Loxia curvirostra percna</i>	Red Crossbills are highly specialized for conifer habitats. Unlogged or mature forests that produce abundant cones are this bird's preferred habitat. Habitats that furnish the Red Crossbill percna subspecies with conifer seeds are large, mature black spruce and balsam fir stands and, on smaller scales throughout the island, red pine, white pine, and white spruce stands. In addition to foraging in these stands, the bird also roosts and nests there; however, the foraging sites can be distant from the roosting and nesting sites. Because this subspecies is hard to identify in the field, it is not certain that all of the Red Crossbills observed in Newfoundland have, in fact, been of the rare percna subspecies.	Yes	Moderate
Rusty Blackbird	<i>Euphagus carolinus</i>	The Rusty Blackbird nests in the boreal forest and favours the shores of wetlands such as slow-moving streams, peat bogs, marshes, swamps, beaver ponds and pasture edges. In wooded areas, the Rusty Blackbird only rarely enters the forest interior. During the winter, the Rusty Blackbird mainly frequents damp forests and, to a lesser extent, cultivated fields.	Yes	Low

Note: These were identified by ACCDC as potentially occurring within the MDA and the likelihood of occurrence is based on field observations and habitat suitability.

2.4.4 Other Wildlife Surveys

Little brown bat (*Myotis lucifugus*), a SAR protected under SARA, is likely to occur within the MDA. Little brown bat was given an emergency listing of “Endangered” by SARA in 2014 because of rapid population declines in Canada due to a deadly wildlife disease known as White-nose Syndrome (WNS) (Environment Canada 2014).

Wildlife Survey Methods

Baseline wildlife surveys occurred concurrently with bird, wetland and vegetation surveys in early July and August 2017. During these surveys all habitat types were traversed in the MDA.

Evidence of wildlife, including small mammals, furbearers, black bear (*Ursus americanus*), moose (*Alces alces*), and amphibians were recorded if and when encountered. Evidence of the presence of these animals consisted of observations of tracks, scat, auditory detections, etc.

Wildlife Survey Results

A variety of wildlife species was detected on the trails and forests within the MDA, including mammals, and amphibians. Mammal species detected during the surveys included moose, black bear, beaver (*Castor canadensis*), red fox (*Vulpes vulpes*), red squirrel (*Tamiasciurus hudsonicus*), and snowshoe hare (*Lepus americanus*). These species were detected from scat and tracks, except for red squirrel, which was directly observed throughout the MDA. Moose was the most commonly detected mammal species in the MDA. Other mammals that may be found in the area but were not detected on surveys include beaver (*Castor canadensis*), American marten (*Martes americana*), American mink (*Neovison vison*), ermine (*Mustela erminea*), coyote (*Canis latrans*), little brown bat (*Myotis lucifugus*), deermouse (*Peromyscus maniculatus*), masked shrew (*Sorex cinereus*), and red backed vole (*Myodes rutilus*).

Green frog (*Lithobates clamitans*) was the only amphibian species detected during surveys. However, American toad (*Anaxyrus americanus*), wood frog (*Lithobates sylvaticus*), and mink frogs (*Lithobates septentrionalis*) are known to occur on the island and are likely present within the MDA.

In general, the MDA appears to have a relatively low diversity and abundance of mammal and amphibian species. No evidence of SAR was detected in the MDA during surveys. However, it is probable that little brown bat, a federally Endangered species, is using the area.

Table 5 summarizes the habitat requirements of SAR wildlife species identified by the ACCDC as potentially occurring within the MDA. Table 5 also indicates the likelihood of occurrence for these species based on field observations and observed habitat within the MDA.

Table 5: Summary of Wildlife Species at Risk

Species	Scientific Name	Habitat Summary	Habitat Present	Likelihood of Occurrence
Newfoundland Marten	<i>Martes americana atrata</i>	The atrata subspecies of the American Marten is found in Canada, on the island of Newfoundland and in northern Quebec and Labrador. The Newfoundland population occurs only on the island of Newfoundland. The Newfoundland population of the American Marten is currently found in three main forest patches in western Newfoundland (Little Grand Lake, Red Indian Lake and Main River) and on the east coast of Newfoundland (Terra Nova National Park of Canada). Smaller populations occur in peripheral areas near St. George's and Lobster House Hill. Newfoundland Marten prefer mature (old growth) coniferous and mixed-wood forests and coniferous forests of varying ages. Martens require dense overhead cover, coarse woody debris, shrubs, and trees with low-hanging branches.	Yes	Low - Moderate
Polar Bear	<i>Ursus maritimus</i>	In Canada, the species is found in ice-covered regions from Yukon and the Bering Sea in the west to Newfoundland and Labrador in the east and from northern Ellesmere Island south to James Bay. The bears are found mainly in the coastal regions of the Arctic Ocean and in the channels between the islands. The Polar Bear frequents the southern edge of the multi-year pack ice of the Arctic Ocean (the ice-covered waters surrounding the North Pole). It is commonly found in coastal areas and in the channels between the islands and archipelagos of the Arctic.	Yes	Low

Note: These were identified by ACCDC as potentially occurring within the MDA and the likelihood of occurrence is based on field observations and habitat suitability.

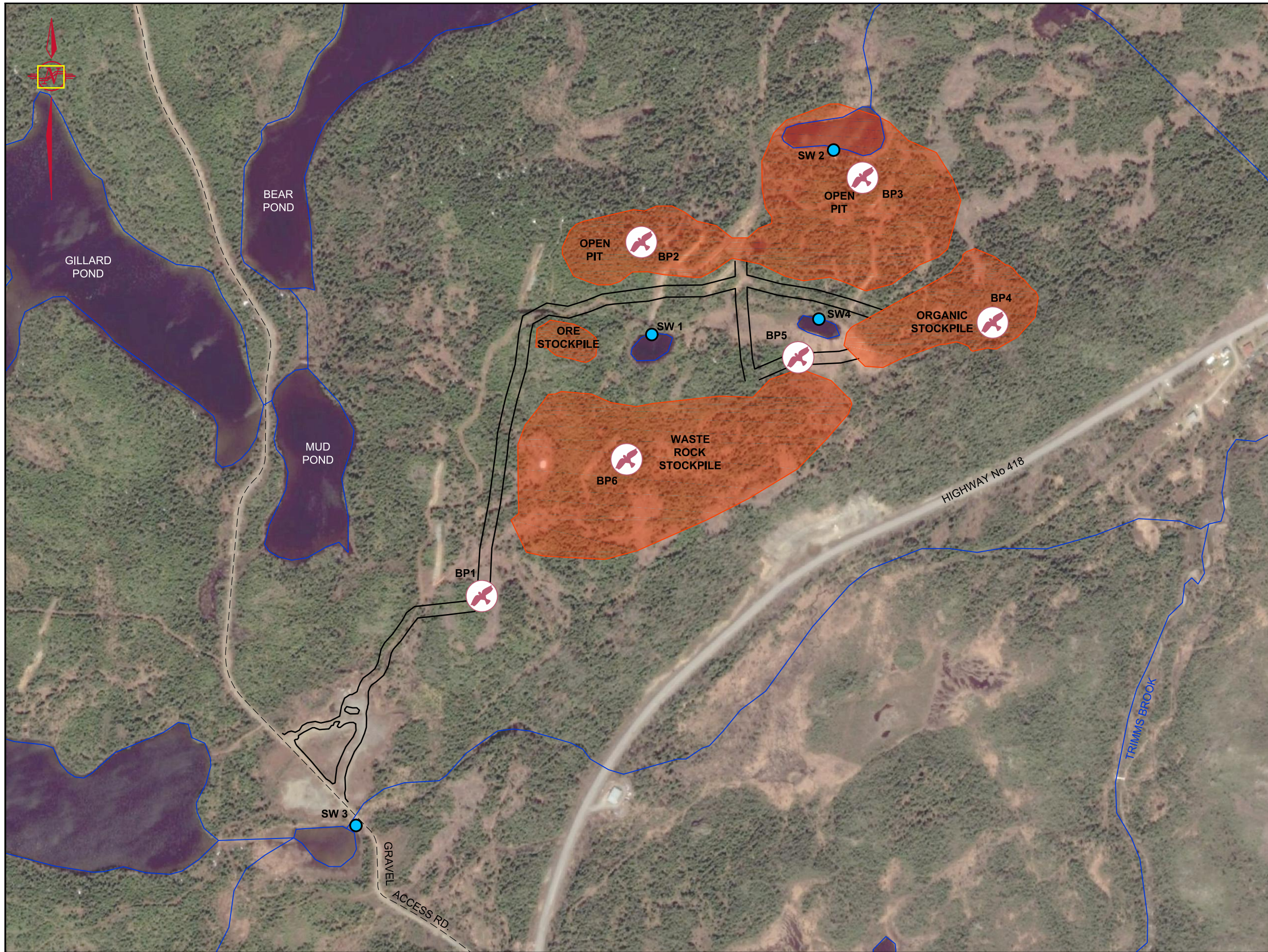

Legend	
	BIRD POINT (BP) COUNT LOCATION
	SURFACE WATER
	WATERCOURSE
	PROPOSED ROAD
	PROPOSED MINE DEVELOPMENT AREA

Note
 1. THIS DRAWING IS A SCHEMATIC REPRESENTATION. SIZES, LOCATIONS AND DIMENSIONS ARE APPROXIMATE.
 2. AERIAL PHOTOGRAPH FROM 2015. SOURCE GOOGLE EARTH.

Drawn By	CHG	Checked By	DR
Calculations By	---	Checked By	---

Date
 JANUARY 2018

Project
 ARGYLE BASELINE STUDIES

Drawing
 BIRD POINT COUNT AND SURFACE WATER SAMPLE LOCATIONS

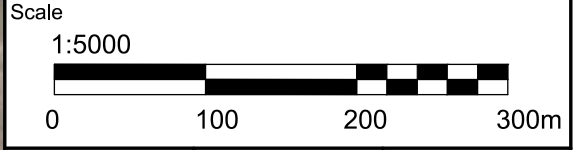

File No.	Drawing	Revision No.
800160901	FIGURE 5	0



N:\DRAWINGS\80000\80016_09\800160901.DWG

2.5 Aquatic Habitat Assessment

A visual/qualitative assessment of the potential for fish and fish habitat was carried out to determine if the aquatic habitats present could potentially support fish populations. The visual assessment noted waterbody type, flow regime, substrate type, and accessibility from downstream waters that could support fish populations. Assessments were made from shorelines of any accessible waterbodies.

2.5.1 Wetland and Surface Water Features

There are several surface water features within the MDA (Figure 3). Wetland 3 and 6 contain ponded surface water features, however, both are groundwater-fed fens without inflows or outflows, making them unsuitable as fish habitat. Wetland 4 also contains a very small ephemeral pond that does not have an inlet or outlet. The substrate in all ponds consists of peaty muck. An ephemeral drainage was identified at the outlet of Wetland 2. This drainage flowed over a very steep slope and was deemed incapable of supporting fish. As mentioned previously, there is a mapped watercourse that appears as part of the provincial watercourse inventory flowing through and discharging from WL6. No obvious evidence of this watercourse was observed within the MDA. A watercourse may be present further down gradient; however this area was not investigated as it is well outside the MDA and scope of study.

2.5.2 Wetland 1 and Unnamed Tributary

Wetland 1 was classified as a wetland complex and is connected to a lake to the west (Figure 3). A significant portion of this wetland consists of a shallow pond with a gravel/cobble substrate and the maximum depth is unknown, but expected to be less than 2 m based on the surrounding geomorphology and landscape position. The pond was sparsely vegetated along the margins with Slender sedge (*Carex lasiocarpa*), Water lobelia (*Lobelia dortmanna*) and pondweed (*Potamogeton spp.*). The outlet of Wetland 1 consists of a stream channel with a gravel/cobble substrate with a gentle channel gradient within the MDA and increases significantly as it flows east down a steep hillside toward Route 418. Wetland 1 appears to provide aquatic pond habitats capable of supporting fish. The unnamed watercourse flowing east may support fish in the upper reaches; however, fish passages may be impeded due to steep channel gradient.

Banded Kill fish (*Fundulus diaphanus*), a SAR fish species identified by the ACCDC as potentially occurring in the MDA is unlikely to inhabit the Wetland 1 pond because it cannot use inland waters where there are barriers to migration such as steep gradients like those observed along the unnamed tributary discharging from Wetland 1.

2.6 Surface Water Quality Monitoring and Sampling

To determine baseline conditions with respect to water quality across the site, field water quality measurements were collected at four locations (SW-1 to SW-4) to evaluate general property conditions using a Horiba multi-parameter water quality meter. Those measurements included:

- pH;

- temperature;
- conductivity;
- dissolved oxygen;
- turbidity; and
- TDS.

In addition to collecting in-situ measurements, surface water samples were also collected at each of the four locations on July 7, 2017 and submitted for laboratory analysis of general chemistry and total metals. One duplicate sample (SW4A) was collected at location SW4 for quality assurance, quality control purposes. All samples were collected in clean laboratory-supplied bottles and submitted to AGAT laboratories in St. John's for analysis.

Surface water quality monitoring and sampling locations are presented in Table 6.

Table 6: Surface Water Quality Monitoring and Sampling Locations

Station ID	Northing	Easting
SW-1	567363	5536339
SW-2	567596	5536575
SW-3	566984	5535709
SW-4	567577	5536358

The Canadian Council of Ministers of the Environment (CCME) Water Quality Guidelines for the Protection of Freshwater Aquatic Life (FWAL) provide applicable criteria for assessing water quality.

2.6.1 Surface Water Quality Monitoring and Sampling Results

Field parameters were measured at the time of sample collection and results are presented in Table 7.

Table 7: Field Water Quality Monitoring Results

Parameter	SW-1	SW-2	SW-3	SW-4
pH (pH units)	7.5	7.67	7.31	7.09
Temperature (°C)	18.7	19.5	18.74	19.9
Conductivity (µS/cm)	63.6	80.2	51.7	51.6
Dissolved Oxygen (mg/L)	8.89	8.18	8.81	9.25
Turbidity (NTU)	0.91	1.75	0.41	0.71
TDS (g/L)	47	58	38	37

Field parameters can be summarized as follows:

- Water temperatures ranged from 18.7 to 19.9 C;
- Field pH ranged from 7.09 to 7.67
- Dissolved Oxygen ranged from 8.18 mg/L to 9.25 mg/L; and
- Conductivity ranged from 51.6 $\mu\text{S}/\text{cm}$ to 80.2 $\mu\text{S}/\text{cm}$.

In addition to the field monitoring, surface water samples were collected at each of the four locations and submitted for laboratory analysis of general chemistry and total metals. One duplicate sample (SW4A) was collected at location SW4 for quality assurance, quality control purposes. The surface water laboratory test results are presented in Table H1 and H2 in Appendix H. Laboratory certificates of analysis are included in Appendix I.

Parameters outside the CCME FWAL guidelines are as follows:

- Aluminum concentrations of 102 $\mu\text{g}/\text{L}$ exceeded the guideline limit of 100 $\mu\text{g}/\text{L}$ in SW-1.

3.0 Conclusions

Based on the findings of these studies, the following conclusions are presented:

- The Project is located within an area having low historic resource potential;
- A total of 6 wetlands were identified within the proposed MDA. The delineated wetlands ranged in size from approximately 0.03 hectares to 4.7 hectares; however, several wetlands extended beyond the MDA. In general, the encountered wetlands have high wetland functionality in native plant habitat;
- The concentration of aluminum (102 $\mu\text{g}/\text{L}$) in surface water sample SW-1 exceeded the Canadian Water Quality Guidelines for the Protection of Freshwater Aquatic Life (CCME FWAL) limit of 100 $\mu\text{g}/\text{L}$. All other total metals and general chemistry were below laboratory detection limits or below the CCME FWAL criteria;
- One rare vascular flora species was identified within the MDA: Common wintergreen (*Chimaphila umbellata*);
- There is little or no viable fish habitat in the MDA; therefore the potential for fish to be present is very low; and
- A total of 20 bird species comprising of 89 individuals were documented during the Breeding Bird Survey. None of the species recorded are considered SAR.

4.0 Closure

This report has been prepared for the sole benefit of our client, Anaconda Mining Inc. The report may not be relied upon by any other person or entity without the express written consent of GEMTEC Consulting Engineers and Scientists and our client, Anaconda Mining Inc.

Any use that a third party makes of this report, or any reliance or decisions made based on it, is the responsibility of such third parties. GEMTEC accepts no responsibility for damages, if any, suffered by any third party as a result of decisions made or actions based on this report.

The information presented within this report represents the best judgment of the trained professional and technical staff based on current standards, site and project information known at the time and project area conditions observed by staff at the time the work was performed.

Should additional information become available, GEMTEC Limited requests that this information be brought to our attention so that we may re-assess the conclusions presented herein.

5.0 References

- Atlantic Canada Conservation Data Centre (ACCDC). 2017. Data Report RQ0616: Baie Verte, NL.
- Canadian Wetland Classification System (2nd Ed.). (1997). University of Waterloo, Waterloo, ON
- Environmental Laboratory. 1987. Army Corp of Engineers Wetlands Delineation Manual. Technical report Y-87-1, U.S Army Engineer Waterways Experiment Station Vicksburg, MS.
- Canadian Council of Ministers of the Environment. 2015. Water Quality Guidelines for the Protection of Aquatic Life (Freshwater).
- Committee on the Status of Endangered Wildlife in Canada (COSEWIC). 2017. Accessed August 28, 2017. Website: http://www.cosewic.gc.ca/eng/sct5/index_e.cfm
- Environment Canada (online). 2014. http://www.registrelep-sararegistry.gc.ca/virtual_sara/files/gen_info/fs_chauvesouris_bats_gen-v03_0215_e.pdf
- Environment and Climate Change Canada. 2017. Migratory Birds Convention Act (1994). Published by the Minister of Justice at the following address <http://laws-lois.justice.gc.ca>.
- Maritime Breeding Bird Atlas. 2006. Guide for Atlassers. Online: <http://www.mba-aom.ca/english/mbbaguide.pdf> Accessed October 2017.
- Species At Risk Public Registry. 2013. Accessed October, 2017. Website: http://www.sararegistry.gc.ca/species/speciesDetails_e.cfm?sid=286
- US Army Corps of Engineers. 2012. Regional Supplement to the Corps of Engineers Wetland Delineation Manual: Northcentral and Northeast Region (Version 2.0)
- .

Appendix A
Wetland Photos



Photo 1: Wetland 1, viewed west from access road (July 5, 2017).



Photo 2: Wetland 1, viewed east from access road (July 5, 2017).



Photo 3: Wetland 2, viewed southwest (July 5, 2017).



Photo 4: Wetland 2, viewed south (July 5, 2017).



Photo 5: Wetland 3, viewed west showing ponded water (July 5, 2017).



Photo 6: Wetland 3, viewed east showing (July 5, 2017).



Photo 7: Wetland 4, viewed east showing ponded water (July 5, 2017).



Photo 8: Wetland 4, viewed north (July 5, 2017).



Photo 9: Wetland 5, viewed north (July 5, 2017).



Photo 10: Wetland 6, viewed northeast showing ponded water (July 5, 2017).



Photo 11: Wetland 6, viewed south showing ponded water (July 5, 2017).

Appendix B
Habitat Photos



Photo 1: Mature balsam fir/black spruce habitat (July 7, 2017).



Photo 2: Young balsam fir/black spruce habitat (July 7, 2017).



Photo 3: Disturbed area (July 7, 2017).

Appendix C
ACCDC Info

Office 365 Outlook



Darrol Rice

[New](#) | [Reply all](#) | [Delete](#) | [Archive](#) | [Junk](#) | [Sweep](#) | [Move to](#) | [Categories](#)[Undo](#)

RE: Data Request

DA Durocher, Adam <AdamDurocher@gov.nl.ca>
Thu 5/18, 5:35 PM
Darrol Rice

[Reply all](#) |

To help protect your privacy, some content in this message has been blocked. To re-enable the blocked features, [click here](#).

To always show content from this sender, [click here](#).

You forwarded this message on 5/24/2017 9:21 PM

[Download](#)

Hi Darrol,

Attached are the species at risk data request results for your site at the Argyle Property outside Ming's Bight, Newfoundland and Labrador.

Summary: Within your study area, there were no rare animal or rare plant records found. **In the case of zero result data requests, there is no charge for the work.**

Secondly, a new addition to our standard data requests is the use of Expert Opinion Maps. These maps are the result of our work with species-specific experts to gather suggestions about locations where species at risk - either provincially, SARA or COSEWIC listed - may be found. While we don't have observations in our database for these species within your study area, our Expert Opinion Maps suggest that Banded Killifish, Ivory Gulls, Mountain Holly Fern, Red Crossbills and Rusty Blackbirds are *possible*, while Polar Bears in the spring & summer, Boreal Felt Lichen and Newfoundland Marten are *possible, but unlikely* in your area. Your area is also said to be within the Barrow's Goldeneye's *range*.

For more information, including a map absent of rare fauna/flora locations for your area, please refer to the following attached document: Map.jpg - shows the location of the 5 km buffer around your site outside Ming's Bight.

Please do not hesitate to contact me if you have any questions.

Adam Durocher
Data Manager
Atlantic Canada Conservation Data Centre

Adam

1 of 16

GIS Scan of Rare and Provincially/Federally Listed Species for Argyle Property near Ming's Bight, Newfoundland and Labrador

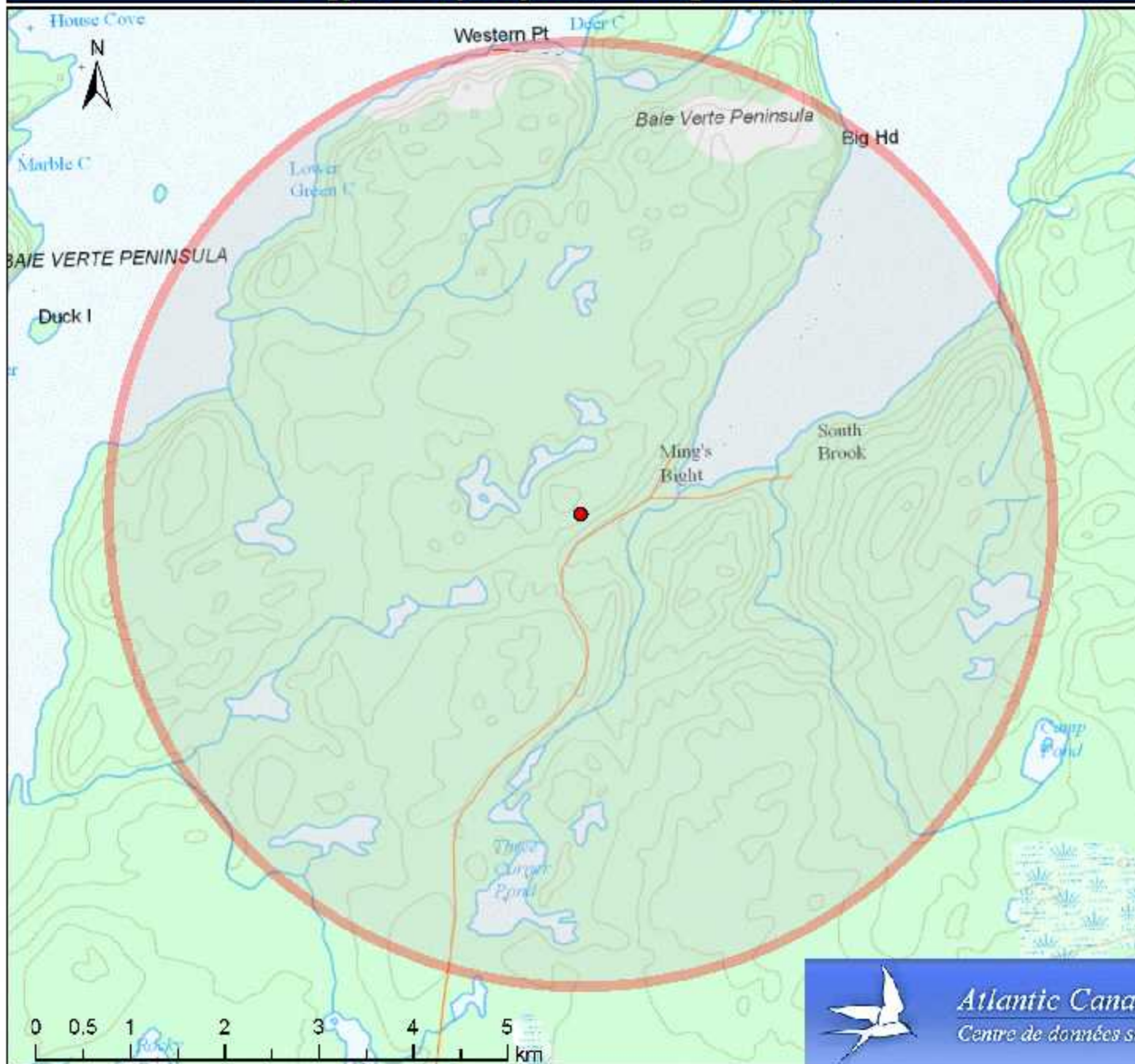

Legend

- Point of Interest (POI)
- 5 km Buffer Around POI

Atlantic Canada Conservation Data Centre
May 18, 2017
For: GEMTEC Ltd.
Data Request: RQ0616

Datum: Transverse Mercator NAD83
Note: Interpretations of this map should
always be conducted in relation with
data provided in spreadsheets and any
other communications.



Atlantic Canada Conservation Data Centre
Centre de données sur la conservation du Canada Atlantique

TABLE C1: SPECIES STATUS

Common Name	Scientific Name	COSEWIC	SARA	NFLD SAR
Flora				
Mountain Holly Fern	<i>Polystichum scopulinum</i>	Threatened	Threatened	-
Boreal Felt Lichen	<i>Erioderma pedicellatum</i>	Special Concern	Special Concern	Vulnerable
Fauna				
Banded Killfish	<i>Fundulus diaphanus</i>	Special Concern	Special Concern	Vulnerable
Ivory Gull	<i>Pagophila eburnea</i>	Endangered	Endangered	Endangered
Red Crossbill	<i>Loxia curvirostra percna</i>	Threatened	Endangered	Endangered
Rusty Blackbird	<i>Euphagus carolinus</i>	Special Concern	Special Concern	Vulnerable
Polar Bear	<i>Ursus maritimus</i>	Special Concern	Special Concern	Vulnerable
Newfoundland Marten	<i>Martes americana atrata</i>	Threatened	Threatened	Threatened
Barrow's Goldeneye	<i>Bucephala islandica</i>	Special Concern	Special Concern	Vulnerable

TABLE C2: SPECIES HABITAT

Common Name	Scientific Name	Preferred Habitat
Flora		
Mountain Holly Fern	<i>Polystichum scopulinum</i>	In North America, Mountain Holly Fern grows in a specialized habitat consisting of shallow soil with a high concentration of heavy metals over a substrate of rocks containing iron and magnesium silicate (ultramafic rocks), mainly olivine and serpentine. The population on the island of Newfoundland was recorded in 1950 from the Humber West area (North Arm Mountain) in the western part of the island and occurred on the southerly slopes of a serpentine ridge.
Boreal Felt Lichen	<i>Erioderma pedicellatum</i>	Currently believed to exist only in Canada with two disjunct populations: the boreal population (the island of Newfoundland) and the Atlantic population (Nova Scotia and New Brunswick). The boreal population of the lichen is known from a total of 94 existing and historical sites scattered across the western and southern regions of the island of Newfoundland. Typical habitat for the Boreal Felt Lichen is northerly exposed forested slopes where cool and moist conditions prevail throughout most of the year. These mature forest sites are also rich in moisture-loving species such as sphagnum mosses and Cinnamon Fern. In well-lit forests, the Boreal Felt Lichen is found predominantly on tree trunks' whereas in more shaded habitats it is found mostly on branches.
Fauna		
Banded Killifish	<i>Fundulus diaphanus</i>	There are seven known sites for the Newfoundland population of Banded Killifish. The majority of these sites are coastal, in the southwestern portion of the island, although one site is inland, in the Indian Bay watershed of northeastern Newfoundland. Banded Killifish in Newfoundland tend to frequent quiet areas of clear lakes and ponds with a muddy or sandy bottom. For spawning, they depend on warm water where there is abundant submerged aquatic vegetation and considerable detritus. Although this type of habitat is abundant in Newfoundland watersheds, the species occurs only in very restricted areas of one or two of the lakes in the watersheds it occupies. It cannot use inland waters where there are barriers to migration, such as rivers with steep gradients; however, the Banded Killifish does not occur in habitats that meet the understood criteria and that appear to be accessible to existing populations.
Barrow's Goldeneye	<i>Bucephala islandica</i>	Data indicate that it breeds only in Canada with the only confirmed breeding records are from Quebec. Small numbers of this population winter in the Maritime Provinces and along the northern Atlantic coastline in the United States. In Quebec, the eastern population inhabits the balsam fir-white birch forest regions of the province. More specifically, birds appear to be restricted to small, high elevation lakes north of the St. Lawrence Estuary and Gulf. During the non-breeding season, the species spends time in the coastal waters of the Estuary and Gulf.
Ivory Gull	<i>Pagophila eburnea</i>	In Canada, the species breeds exclusively in Nunavut. Wintering occasionally along the eastern coasts of Newfoundland and Labrador, particularly the Great Northern Peninsula of Newfoundland. Outside the breeding season, Ivory Gulls live near the edges of pack ice or drift ice.
Newfoundland Marten	<i>Martes americana atrata</i>	The atrata subspecies of the American Marten is found in Canada, on the island of Newfoundland and in northern Quebec and Labrador. The Newfoundland population occurs only on the island of Newfoundland. The Newfoundland population of the American Marten is currently found in three main forest patches in western Newfoundland (Little Grand Lake, Red Indian Lake and Main River) and on the east coast of Newfoundland (Terra Nova National Park of Canada). Smaller populations occur in peripheral areas near St. George's and Lobster House Hill. Newfoundland Marten prefer mature (old growth) coniferous and mixed-wood forests and coniferous forests of varying ages. Martens require dense overhead cover, coarse woody debris, shrubs, and trees with low-hanging branches.
Polar Bear	<i>Ursus maritimus</i>	In Canada, the species is found in ice-covered regions from Yukon and the Bering Sea in the west to Newfoundland and Labrador in the east and from northern Ellesmere Island south to James Bay. The bears are found mainly in the coastal regions of the Arctic Ocean and in the channels between the islands. The Polar Bear frequents the southern edge of the multi-year pack ice of the Arctic Ocean (the ice-covered waters surrounding the North Pole). It is commonly found in coastal areas and in the channels between the islands and archipelagos of the Arctic.
Red Crossbill	<i>Loxia curvirostra percna</i>	Red Crossbills are highly specialized for conifer habitats. Unlogged or mature forests that produce abundant cones are this bird's preferred habitat. Habitats that furnish the Red Crossbill percna subspecies with conifer seeds are large, mature black spruce and balsam fir stands and, on smaller scales throughout the island, red pine, white pine, and white spruce stands. In addition to foraging in these stands, the bird also roosts and nests there; however, the foraging sites can be distant from the roosting and nesting sites. Because this subspecies is hard to identify in the field, it is not certain that all of the Red Crossbills observed in Newfoundland have in fact been of the rare percna subspecies.
Rusty Blackbird	<i>Euphagus carolinus</i>	The Rusty Blackbird nests in the boreal forest and favours the shores of wetlands such as slow-moving streams, peat bogs, marshes, swamps, beaver ponds and pasture edges. In wooded areas, the Rusty Blackbird only rarely enters the forest interior. During the winter, the Rusty Blackbird mainly frequents damp forests and, to a lesser extent, cultivated fields.

Appendix D
Plant Inventory

Scientific Name	Common Name	SRank
<i>Abies balsamea</i>	Balsam Fir	S5
<i>Acer spicatum</i>	Mountain Maple	S5
<i>Achillea millefolium</i>	Common Yarrow	SNA
<i>Alnus incana</i>	Speckled Alder	S5
<i>Amelanchier bartramiana</i>	Bartram Shadbush	S5
<i>Anaphalis margaritacea</i>	Pearly Everlasting	S5
<i>Aralia hispida</i>	Bristly Sarsaparilla	S3S4
<i>Aralia nudicaulis</i>	Wild Sarsaparilla	S5
<i>Arethusa bulbosa</i>	Swamp-Pink	S4S5
<i>Athyrium filix-femina</i>	Lady-Fern	S5
<i>Betula cordifolia</i>	Mountain paper birch	S4S5
<i>Calamagrostis canadensis</i>	Blue-Joint Reedgrass	S5
<i>Carex bigelowii</i>	Bigelow Sedge	S3S4
<i>Carex brunnescens</i>	Brownish Sedge	S5
<i>Carex canescens</i>	Hoary Sedge	S5
<i>Carex castanea</i>	Chestnut-Colored Sedge	S3S4
<i>Carex disperma</i>	Softleaf Sedge	S4S5
<i>Carex echinata</i>	Little Prickly Sedge	S5
<i>Carex exilis</i>	Coast Sedge	S5
<i>Carex flava</i>	Yellow Sedge	S4S5
<i>Carex lasiocarpa</i>	Slender Sedge	S5
<i>Carex lenticularis</i>	Shore Sedge	S4
<i>Carex leptalea</i>	Bristly-Stalk Sedge	S4S5
<i>Carex leptonevia</i>	Finely-Nerved Sedge	S4S5
<i>Carex limosa</i>	Mud Sedge	S5
<i>Carex magellanica</i>	A Sedge	S5
<i>Carex michauxiana</i>	Michaux Sedge	S4S5

Scientific Name	Common Name	SRank
<i>Carex nigra</i>	Black Sedge	S5
<i>Carex oligosperma</i>	Few-Seeded Sedge	S5
<i>Carex pallescens</i>	Pale Sedge	S3
<i>Carex rostrata</i>	Beaked Sedge	S3S4
<i>Carex trisperma</i>	Three-Seed Sedge	S5
<i>Carex viridula</i>	Little Green Sedge	S5
<i>Chamaedaphne calyculata</i>	Leatherleaf	S5
<i>Chamerion angustifolium</i>	Fireweed	S5
<i>Chimaphila umbellata</i>	Common Wintergreen	S2
<i>Circaea alpina</i>	Small Enchanter's Nightshade	S5
<i>Clintonia borealis</i>	Clinton Lily	S5
<i>Corallorhiza maculata</i>	Spotted Coralroot	S3S4
<i>Cornus canadensis</i>	Dwarf Dogwood	S5
<i>Danthonia spicata</i>	Poverty Oat-Grass	S5
<i>Dasiphora fruticosa</i>	Golden-Hardhack	S4S5
<i>Doellingeria umbellata</i>	Parasol White-Top	S5
<i>Drosera intermedia</i>	Spoon-Leaved Sundew	S4S5
<i>Drosera rotundifolia</i>	Roundleaf Sundew	S5
<i>Dryopteris carthusiana</i>	Spinulose Shield Fern	S4
<i>Dryopteris cristata</i>	Crested Wood Fern	S3S4
<i>Dryopteris expansa</i>	Spreading Woodfern	S3S4
<i>Dryopteris intermedia</i>	Glandular Wood Fern	S5
<i>Empetrum nigrum</i>	Black Crowberry	S5
<i>Epilobium ciliatum</i>	Hairy Willow-Herb	S5
<i>Epilobium leptophyllum</i>	Linear-Leaved Willow-Herb	S3
<i>Equisetum arvense</i>	Field Horsetail	S5
<i>Equisetum sylvaticum</i>	Woodland Horsetail	S5

Scientific Name	Common Name	SRank
<i>Eriocaulon aquaticum</i>	Seven-Angled Pipewort	S5
<i>Eriophorum russeolum</i>	Russet Cotton-Grass	S3
<i>Eriophorum vaginatum</i>	Tussock Cotton-Grass	S5
<i>Eriophorum virginicum</i>	Tawny Cotton-Grass	S4S5
<i>Euphrasia nemorosa</i>	Common Eyebright	S4S5
<i>Eurybia radula</i>	Rough-Leaved Aster	S5
<i>Euthamia graminifolia</i>	Flat-Top Fragrant-Golden-Rod	S5
<i>Gaultheria hispidula</i>	Creeping Snowberry	S5
<i>Geum rivale</i>	Purple Avens	S4S5
<i>Glyceria canadensis</i>	Canada Manna-Grass	S5
<i>Glyceria striata</i>	Fowl Manna-Grass	S5
<i>Gymnocarpium dryopteris</i>	Northern Oak Fern	S5
<i>Hypericum perforatum</i>	A St. John's-Wort	SNA
<i>Ilex mucronata</i>	Mountain holly	S5
<i>Iris versicolor</i>	Blueflag	S5
<i>Juncus articulatus</i>	Jointed Rush	S5
<i>Juncus effusus</i>	Soft Rush	S5
<i>Juniperus communis</i>	Ground Juniper	S5
<i>Kalmia angustifolia</i>	Sheep-Laurel	S5
<i>Kalmia polifolia</i>	Pale Laurel	S5
<i>Larix laricina</i>	American Larch	S5
<i>Leontodon autumnalis</i>	Autumn Hawkbit	SNA
<i>Leucanthemum vulgare</i>	Oxeye Daisy	SNA
<i>Linnaea borealis</i>	Twinflower	S5
<i>Lobelia dortmanna</i>	Water Lobelia	S5
<i>Lonicera villosa</i>	Mountain Fly-Honeysuckle	S5
<i>Lupinus polyphyllus</i>	Lupine	SNA

Scientific Name	Common Name	SRank
<i>Lycopodium annotinum</i>	Stiff Clubmoss	S5
<i>Lysimachia terrestris</i>	Swamp Loosestrife	S5
<i>Maianthemum canadense</i>	Wild Lily-of-The-Valley	S5
<i>Maianthemum trifolium</i>	Three-Leaf Solomon's-Plume	S5
<i>Malaxis unifolia</i>	Green Adder's-Mouth	S3
<i>Menyanthes trifoliata</i>	Bog Buckbean	S5
<i>Mitella nuda</i>	Naked Bishop's-Cap	S5
<i>Moneses uniflora</i>	One-Flower Wintergreen	S5
<i>Monotropa uniflora</i>	Indian-Pipe	S5
<i>Myrica gale</i>	Sweet Bayberry	S5
<i>Neottia cordata</i>		S5
<i>Nuphar variegata</i>	Yellow Cowlily	S5
<i>Oclemena nemoralis</i>	Bog Aster	S5
<i>Orthilia secunda</i>	One-Side Wintergreen	S5
<i>Osmundastrum cinnamomeum</i>	Cinnamon fern	S5
<i>Packera aurea</i>	Golden Groundsel	S3S4
<i>Phleum pratense</i>	Meadow Timothy	SNA
<i>Picea mariana</i>	Black Spruce	S5
<i>Platanthera clavellata</i>	Club-Spur Orchid	S5
<i>Platanthera dilatata</i>	Leafy White Orchis	S5
<i>Platanthera psycodes</i>	Small Purple Fringed Orchid	S4S5
<i>Pogonia ophioglossoides</i>	Snakemouth	S4
<i>Populus tremuloides</i>	Quaking Aspen	S4S5
<i>Potamogeton epihydrus</i>	Nuttall Pondweed	S4S5
<i>Potentilla anserina</i>	Silverweed	S5
<i>Potentilla norvegica</i>	Norwegian Cinquefoil	S4S5
<i>Prunella vulgaris</i>	Self-Heal	S3S5

Scientific Name	Common Name	SRank
<i>Prunus pensylvanica</i>	Fire Cherry	S4S5
<i>Pteridium aquilinum</i>	Bracken fern	S4S5
<i>Pyrola asarifolia</i>	Pink Wintergreen	S4
<i>Pyrola chlorantha</i>	Greenish-Flowered Wintergreen	S3S4
<i>Pyrola minor</i>	Lesser Wintergreen	S4
<i>Ranunculus acris</i>	Tall Butter-Cup	SNA
<i>Ranunculus repens</i>	Creeping Butter-Cup	SNA
<i>Rhamnus alnifolia</i>	Alderleaf Buckthorn	S5
<i>Rhinanthus minor</i>	Little Yellow-Rattle	S3
<i>Rhododendron canadense</i>	Rhodora	S5
<i>Rhododendron groenlandicum</i>	Labrador tea	S5
<i>Rhynchospora alba</i>	White Beakrush	S4S5
<i>Ribes glandulosum</i>	Skunk Currant	S5
<i>Ribes lacustre</i>	Bristly Black Currant	S4
<i>Ribes triste</i>	Swamp Red Currant	S4
<i>Rosa nitida</i>	Shining Rose	S4S5
<i>Rubus arcticus</i>	Northern Blackberry	S3S4
<i>Rubus chamaemorus</i>	Cloudberry	S5
<i>Rubus idaeus</i>	Red Raspberry	S5
<i>Rubus pubescens</i>	Dwarf Red Raspberry	S5
<i>Salix discolor</i>	Pussy Willow	S5
<i>Salix humilis</i>	Prairie Willow	S5
<i>Salix pyrifolia</i>	Balsam Willow	S4
<i>Sanguisorba canadensis</i>	Canada Burnet	S5
<i>Sarracenia purpurea</i>	Northern Pitcher-Plant	S5
<i>Scirpus atrocinctus</i>	Black-Girdle Bulrush	S5
<i>Scirpus microcarpus</i>	Small-Fruit Bulrush	S4S5

Scientific Name	Common Name	SRank
<i>Solidago macrophylla</i>	Large-Leaf Goldenrod	S5
<i>Solidago rugosa</i>	Rough-Leaf Goldenrod	S5
<i>Solidago uliginosa</i>	Bog Goldenrod	S5
<i>Sorbus decora</i>	Northern Mountain-Ash	S5
<i>Sparganium fluctuans</i>	Floating Bur-Reed	S2S3
<i>Spiranthes romanzoffiana</i>	Hooded Ladies'-Tresses	S4S5
<i>Streptopus lanceolatus</i>	Rosy Twistedstalk	S4
<i>Symphotrichum puniceum</i>	Swamp Aster	S5
<i>Taraxacum officinale</i>	Common Dandelion	SNA
<i>Taxus canadensis</i>	Canadian Yew	S3S4
<i>Thalictrum pubescens</i>	Tall Meadow-Rue	S5
<i>Thelypteris palustris</i>	Marsh Fern	S3S4
<i>Triadenum fraseri</i>	Marsh St. John's-Wort	S5
<i>Trichophorum alpinum</i>	Alpine Cotton-Grass	S4S5
<i>Trichophorum cespitosum</i>	deergrass	S5
<i>Trientalis borealis</i>	Northern Starflower	S5
<i>Trifolium hybridum</i>	Alsike Clover	SNA
<i>Trifolium repens</i>	White Clover	SNA
<i>Triglochin maritima</i>	Common Bog Arrow-Grass	S5
<i>Tussilago farfara</i>	Colt's-foot	SNA
<i>Utricularia intermedia</i>	Flatleaf Bladderwort	S5
<i>Vaccinium angustifolium</i>	Late Lowbush Blueberry	S5
<i>Vaccinium oxycoccos</i>	Small Cranberry	S5
<i>Vaccinium vitis-idaea</i>	Mountain Cranberry	S5
<i>Viburnum edule</i>	Squashberry	S5

Appendix E
Rare Plant Photos



Photo 1: Common wintergreen (*Chimaphila umbellata*) in flower (Aug 10, 2017).



Photo 2: Common wintergreen (*Chimaphila umbellata*) habitat (Aug 10, 2017).

Appendix F

Rare Plant Locations (Common Wintergreen)

Appendix F: Rare Plant Locations (Common Wintergreen)

Scientific Name	Common Name	No. Plants	Area (m ²)	Location*	
				x	y
Chimaphila umbellata	Common wintergreen	40	5	300330.8	5537632.2
Chimaphila umbellata	Common wintergreen	50	25	300325.8	5537647.2
Chimaphila umbellata	Common wintergreen	4	4	300369.3	5537657.8
Chimaphila umbellata	Common wintergreen	100	100	300360.9	5537638.0
Chimaphila umbellata	Common wintergreen	50	25	300416.8	5537671.4
Chimaphila umbellata	Common wintergreen	15	1	300423.7	5537690.3
Chimaphila umbellata	Common wintergreen	2	1	300422.4	5537690.7
Chimaphila umbellata	Common wintergreen	7	1	300415.1	5537717.0
Chimaphila umbellata	Common wintergreen	3	1	300420.5	5537692.0
Chimaphila umbellata	Common wintergreen	4	2	300447.9	5537720.6
Chimaphila umbellata	Common wintergreen	80	45	300489.8	5537657.0
Chimaphila umbellata	Common wintergreen	35	4	300480.2	5537651.3
Chimaphila umbellata	Common wintergreen	36	4	300406.2	5537590.1
Chimaphila umbellata	Common wintergreen	42	9	300402.5	5537591.1
Chimaphila umbellata	Common wintergreen	75	25	300397.2	5537588.9
Chimaphila umbellata	Common wintergreen	6	2	300386.8	5537574.9
Chimaphila umbellata	Common wintergreen	2	1	300380.9	5537568.4
Chimaphila umbellata	Common wintergreen	3	1	300356.8	5537555.6
Chimaphila umbellata	Common wintergreen	22	4	300317.8	5537537.3
Chimaphila umbellata	Common wintergreen	43	9	300298.2	5537531.9
Chimaphila umbellata	Common wintergreen	60	6	300287.0	5537515.1
Chimaphila umbellata	Common wintergreen	2	1	300301.9	5537501.7
Chimaphila umbellata	Common wintergreen	22	1	300303.2	5537500.8
Chimaphila umbellata	Common wintergreen	25	1	300308.2	5537501.2
Chimaphila umbellata	Common wintergreen	33	2	300314.1	5537502.1
Chimaphila umbellata	Common wintergreen	100	4	300335.2	5537495.2
Chimaphila umbellata	Common wintergreen	22	1	300378.2	5537475.5

Appendix F: Rare Plant Locations (Common Wintergreen)

Scientific Name	Common Name	No. Plants	Area (m ²)	Location*	
				x	y
Chimaphila umbellata	Common wintergreen	33	2	300367.3	5537475.2
Chimaphila umbellata	Common wintergreen	50	4	300365.8	5537471.5
Chimaphila umbellata	Common wintergreen	100	9	300367.2	5537463.2
Chimaphila umbellata	Common wintergreen	200	400	300354.4	5537445.2
Chimaphila umbellata	Common wintergreen	16	16	300182.6	5537197.9
Chimaphila umbellata	Common wintergreen	200	150	300188.7	5537196.9
Chimaphila umbellata	Common wintergreen	16	1	300228.6	5537229.7
Chimaphila umbellata	Common wintergreen	200	100	300299.8	5537313.0
Chimaphila umbellata	Common wintergreen	17	1	300391.3	5537427.9
Chimaphila umbellata	Common wintergreen	34	1	300391.1	5537431.5
Chimaphila umbellata	Common wintergreen	25	2	300397.9	5537435.2
Chimaphila umbellata	Common wintergreen	18	4	300444.2	5537502.3
Chimaphila umbellata	Common wintergreen	28	16	300456.0	5537497.9
Chimaphila umbellata	Common wintergreen	17	1	300754.6	5537588.4
Chimaphila umbellata	Common wintergreen	50	5	300757.8	5537609.8
Chimaphila umbellata	Common wintergreen	23	4	300790.1	5537628.1
Chimaphila umbellata	Common wintergreen	30	4	300776.6	5537616.8
Chimaphila umbellata	Common wintergreen	7	4	300886.0	5537703.9
Chimaphila umbellata	Common wintergreen	100	100	300817.0	5537617.3
Chimaphila umbellata	Common wintergreen	21	1	300771.8	5537713.3
Chimaphila umbellata	Common wintergreen	11	1	300784.5	5537780.2
Chimaphila umbellata	Common wintergreen	31	4	300808.9	5537792.4
Chimaphila umbellata	Common wintergreen	28	1	300804.5	5537768.3
Chimaphila umbellata	Common wintergreen	8	1	300785.3	5537780.0
Chimaphila umbellata	Common wintergreen	10	1	300778.9	5537783.3
Chimaphila umbellata	Common wintergreen	14	1	300711.1	5537712.0
Chimaphila umbellata	Common wintergreen	26	2	300711.0	5537691.4

Appendix F: Rare Plant Locations (Common Wintergreen)

Scientific Name	Common Name	No. Plants	Area (m ²)	Location*	
				x	y
Chimaphila umbellata	Common wintergreen	75	4	300619.2	5537650.3
Chimaphila umbellata	Common wintergreen	17	25	300289.1	5537574.5
Chimaphila umbellata	Common wintergreen	75	4	300306.8	5537579.9
Chimaphila umbellata	Common wintergreen	40	6	300456.7	5537629.7
Chimaphila umbellata	Common wintergreen	40	6	300460.0	5537643.9
Chimaphila umbellata	Common wintergreen	50	6	300524.5	5537624.9
Chimaphila umbellata	Common wintergreen	100	25	300555.3	5537641.6
Chimaphila umbellata	Common wintergreen	300	25	300595.2	5537643.9
Chimaphila umbellata	Common wintergreen	100	10	300608.5	5537645.1
Chimaphila umbellata	Common wintergreen	50	5	300606.3	5537662.2
Chimaphila umbellata	Common wintergreen	23	2	300660.8	5537714.3
Chimaphila umbellata	Common wintergreen	20	1	300675.6	5537761.5
Chimaphila umbellata	Common wintergreen	150	30	300668.9	5537771.1
Chimaphila umbellata	Common wintergreen	7	1	300795.7	5537802.6
Chimaphila umbellata	Common wintergreen	17	1	300790.3	5537812.2
Chimaphila umbellata	Common wintergreen	11	4	300773.1	5537819.3
Chimaphila umbellata	Common wintergreen	100	5	300815.2	5537874.6
Chimaphila umbellata	Common wintergreen	75	1	300766.7	5537894.4
Chimaphila umbellata	Common wintergreen	50	2	300643.0	5537861.5
Chimaphila umbellata	Common wintergreen	2	1	300621.5	5537792.6
Chimaphila umbellata	Common wintergreen	100	6	300200.3	5537161.4
Chimaphila umbellata	Common wintergreen	11	1	300242.0	5537215.2
Chimaphila umbellata	Common wintergreen	50	30	300336.6	5537257.8
Chimaphila umbellata	Common wintergreen	200	25	300347.1	5537248.8
Chimaphila umbellata	Common wintergreen	200	25	300350.2	5537258.5
Chimaphila umbellata	Common wintergreen	20	25	300390.2	5537291.0
Chimaphila umbellata	Common wintergreen	50	20	300387.2	5537276.9

Appendix F: Rare Plant Locations (Common Wintergreen)

Scientific Name	Common Name	No. Plants	Area (m ²)	Location*	
				x	y
Chimaphila umbellata	Common wintergreen	500	150	300381.1	5537268.0
Chimaphila umbellata	Common wintergreen	100	6	300397.1	5537280.6
Chimaphila umbellata	Common wintergreen	75	6	300408.2	5537286.9
Chimaphila umbellata	Common wintergreen	100	4	300478.0	5537377.6
Chimaphila umbellata	Common wintergreen	75	4	300792.1	5537541.4
Chimaphila umbellata	Common wintergreen	6	1	300886.5	5537613.3
Chimaphila umbellata	Common wintergreen	20	4	300908.4	5537604.0
Chimaphila umbellata	Common wintergreen	50	4	300915.2	5537602.6
Chimaphila umbellata	Common wintergreen	35	2	300931.8	5537599.9
Chimaphila umbellata	Common wintergreen	20	4	300958.9	5537627.4
Chimaphila umbellata	Common wintergreen	75	15	300970.8	5537638.0
Chimaphila umbellata	Common wintergreen	25	4	300979.6	5537642.9
Chimaphila umbellata	Common wintergreen	22	2	300814.3	5537602.9
Chimaphila umbellata	Common wintergreen	2	1	300772.4	5537594.2
Chimaphila umbellata	Common wintergreen	20	1	300758.8	5537593.3
Chimaphila umbellata	Common wintergreen	200	25	300599.3	5537531.3
Chimaphila umbellata	Common wintergreen	50	2	300174.4	5536761.2
Chimaphila umbellata	Common wintergreen	100	16	300178.0	5536740.7
Chimaphila umbellata	Common wintergreen	45	2	300182.6	5536746.6

*Coordinate system: NAD1983 CSRS MTM 2

Appendix G

Bird Point Survey Data

Date	Point	Time (am)	Bird Codes	Common Name	Scientific Name	Bearing (°)	Distance (m)	Breeding Code	Number
06-Jul-17	PT1	5:35	DOWO	Downy Woodpecker	Picoides pubescens	20	50	S	1
06-Jul-17	PT1	5:35	FOSP	Fox Sparrow	Passerella iliaca	250	75	S	1
06-Jul-17	PT1	5:35	FOSP	Fox Sparrow	Passerella iliaca	120	75	S	1
06-Jul-17	PT1	5:35	NOTH	Northern Waterthrush	Parkesia noveboracensis	325	50	S	1
06-Jul-17	PT1	5:35	RCKI	Ruby-crowned Kinglet	Regulus calendula	280	100	S	1
06-Jul-17	PT1	5:35	WTSP	White-throated Sparrow	Zonotrichia albicollis	335	40	S	1
06-Jul-17	PT1	5:35	YBFL	Yellow-bellied Flycatcher	Empidonax flaviventris	70	20	X	1
06-Jul-17	PT2	5:50	FOSP	Fox Sparrow	Passerella iliaca	75	100	S	1
06-Jul-17	PT2	5:50	HETH	Hermit Thrush	Catharus guttatus	90	125	S	1
06-Jul-17	PT2	5:50	MAWA	Magnolia Warbler	Setophaga magnolia	140	75	S	1
06-Jul-17	PT2	5:50	WTSP	White-throated Sparrow	Zonotrichia albicollis	45	50	S	1
06-Jul-17	PT2	5:50	YBFL	Yellow-bellied Flycatcher	Empidonax flaviventris	200	50	S	1
06-Jul-17	PT2	5:50	YRWA	Yellow-rumped Warbler	Setophaga coronata	175	100	S	1
06-Jul-17	PT3	6:11	AMRO	American Robin	Turdus migratorius	200	200	S	1
06-Jul-17	PT3	6:11	BHVI	Blue-headed Vireo	Vireo solitarius	275	40	S	1
06-Jul-17	PT3	6:11	FOSP	Fox Sparrow	Passerella iliaca	300	100	S	1
06-Jul-17	PT3	6:11	NOTH	Northern Waterthrush	Parkesia noveboracensis	255	50	S	1
06-Jul-17	PT3	6:11	SWTH	Swainson's Thrush	Catharus ustulatus	20	75	S	1
06-Jul-17	PT3	6:11	YRWA	Yellow-rumped Warbler	Setophaga coronata	300	75	S	1
06-Jul-17	PT4	6:27	AMRO	American Robin	Turdus migratorius	360	50	S	1

Date	Point	Time (am)	Bird Codes	Common Name	Scientific Name	Bearing (°)	Distance (m)	Breeding Code	Number
06-Jul-17	PT4	6:27	BHVI	Blue-headed Vireo	Vireo solitarius	360	50	S	1
06-Jul-17	PT4	6:27	BOCH	Boreal Chickadee	Poecile hudsonicus	90	50	S	1
06-Jul-17	PT4	6:27	BTNW	Black-throated Green Warbler	Dendroica virens	270	75	S	1
06-Jul-17	PT4	6:27	GRJA	Gray Jay	Perisoreus canadensis	360	5	FY	1
06-Jul-17	PT4	6:27	YRWA	Yellow-rumped Warbler	Setophaga coronata	180	100	S	1
06-Jul-17	PT5	6:47	AMRO	American Robin	Turdus migratorius	180	75	S	1
06-Jul-17	PT5	6:47	NOTH	Northern Waterthrush	Parkesia noveboracensis	360	125	S	1
06-Jul-17	PT5	6:47	NOTH	Northern Waterthrush	Parkesia noveboracensis	90	25	S	1
06-Jul-17	PT5	6:47	RCKI	Ruby-crowned Kinglet	Regulus calendula	220	75	S	1
06-Jul-17	PT5	6:47	WTSP	White-throated Sparrow	Zonotrichia albicollis	45	100	S	1
06-Jul-17	PT6	7:15	FOSP	Fox Sparrow	Passerella iliaca	50	50	S	1
06-Jul-17	PT6	7:15	GRJA	Gray Jay	Perisoreus canadensis	180	100	S	1
06-Jul-17	PT6	7:15	HAWO	Hairy Woodpecker	Picoides villosus	90	175	S	1
06-Jul-17	PT6	7:15	NOTH	Northern Waterthrush	Parkesia noveboracensis	40	30	S	1
06-Jul-17	PT6	7:15	RCKI	Ruby-crowned Kinglet	Regulus calendula	270	200	S	1
06-Jul-17	PT6	7:15	RCKI	Ruby-crowned Kinglet	Regulus calendula	340	150	S	1
06-Jul-17	PT6	7:15	WTSP	White-throated Sparrow	Zonotrichia albicollis	10	150	S	1
06-Jul-17	PT6	7:15	YRWA	Yellow-rumped Warbler	Setophaga coronata	280	75	S	1
Incidental			AMRO	American Robin	Turdus migratorius	-	-	X	1
Incidental			ATTW	American tree-toed Woodpecker	Picoides dorsalis	-	-	S	1

Date	Point	Time (am)	Bird Codes	Common Name	Scientific Name	Bearing (°)	Distance (m)	Breeding Code	Number
Incidental			BHVI	Blue-headed Vireo	Vireo solitarius	-	-	S	1
Incidental			BOCH	Boreal Chickadee	Poecile hudsonicus	-	-	S	4
Incidental			BTNW	Black-throated Green Warbler	Dendroica virens	-	-	S	1
Incidental			DEJU	Dark-eyed Junco	Junco hyemalis	-	-	X	1
Incidental			FOSP	Fox Sparrow	Passerella iliaca	-	-	S	1
Incidental			FOSP	Fox Sparrow	Passerella iliaca	-	-	S	1
Incidental			FOSP	Fox Sparrow	Passerella iliaca	-	-	S	1
Incidental			FOSP	Fox Sparrow	Passerella iliaca	-	-	S	1
Incidental			GRJA	Gray Jay	Perisoreus canadensis	-	-	X	1
Incidental			HAWO	Hairy Woodpecker	Picoides villosus	-	-	P	2
Incidental			HETH	Hermit Thrush	Catharus guttatus	-	-	X	1
Incidental			MAWA	Magnolia Warbler	Setophaga magnolia	-	-	S	1
Incidental			MAWA	Magnolia Warbler	Setophaga magnolia	-	-	S	1
Incidental			MAWA	Magnolia Warbler	Setophaga magnolia	-	-	S	1
Incidental			NOTH	Northern Waterthrush	Parkesia noveboracensis	-	-	S	1
Incidental			NOTH	Northern Waterthrush	Parkesia noveboracensis	-	-	S	1
Incidental			NOTH	Northern Waterthrush	Parkesia noveboracensis	-	-	A	1
Incidental			OSPR	Osprey	Pandion haliaetus	-	-	CF	1
Incidental			RCKI	Ruby-crowned Kinglet	Regulus calendula	-	-	S	1
Incidental			RCKI	Ruby-crowned Kinglet	Regulus calendula	-	-	X	1

Date	Point	Time (am)	Bird Codes	Common Name	Scientific Name	Bearing (°)	Distance (m)	Breeding Code	Number
Incidental			WWCR	White-winged Crossbill	<i>Loxia leucoptera</i>	-	-	X	1
Incidental			WWCR	White-winged Crossbill	<i>Loxia leucoptera</i>	-	-	FO	20
Incidental			YBFL	Yellow-bellied Flycatcher	<i>Empidonax flaviventris</i>	-	-	S	1
Incidental			YBFL	Yellow-bellied Flycatcher	<i>Empidonax flaviventris</i>	-	-	S	1
Incidental			YRWA	Yellow-rumped Warbler	<i>Setophaga coronata</i>	-	-	P	2

S Singing
X Observed in breeding season – no breeding evidence
FY Fledged Young
P Pair Observed
A Agitated Behaviour
CF Carrying Food
FO Fly Over

Appendix H

Analytical Data

Table H1: General Chemistry, Surface Water

Sample Station:	Units	CCME FWAL ¹	RDL ²	SW-1	SW-2	SW-3	SW-4	SW-4A (DUP)
				July 7/2017	July 7/2017	July 7/2017	July 7/2017	July 7/2017
Date Sampled:								
Alkalinity	mg/L	-	5	30	39	24	20	21
Ammonia	mg/L	Fact Sheet ³	0.03	<0.03	<0.03	<0.03	<0.03	<0.03
Calcium	mg/L	-	0.1	8.9	12.8	7.5	6.9	6.7
Chloride	mg/L	640 ⁴ , 120 ⁴	1	4	4	4	5	5
Conductivity	µS/cm	-	1	74	94	62	58	59
Fluoride	mg/L	0.12	0.12	<0.12	<0.12	<0.12	<0.12	<0.12
Magnesium	mg/L	-	0.1	1.9	1.9	1.7	1.1	1.1
Nitrate + Nitrite	mg/L	-	0.05	0.07	<0.05	<0.05	<0.05	<0.05
Nitrate	mg/L	550 ⁴ , 13 ⁴	0.05	0.07	<0.05	<0.05	<0.05	<0.05
Nitrite	mg/L	0.06	0.05	<0.05	<0.05	<0.05	<0.05	<0.05
o-Phosphate	mg/L	-	0.01	<0.01	<0.01	<0.01	<0.01	<0.01
pH		6.5-9.0	-	7.44	7.34	7.31	7.36	7.40
Phosphorous	mg/L	Fact Sheet	0.02	0.03	0.03	0.03	0.03	0.02
Potassium	mg/L	-	0.1	0.1	0.2	0.1	0.1	0.2
r-Silica	mg/L	-	0.5	<0.5	0.60	<0.5	<0.5	<0.5
Sodium	mg/L	-	0.1	3.7	4.3	3.8	3.9	3.8
Sulphate	mg/L	-	2	<2	<2	<2	<2	<2
Total Organic Carbon	mg/L	-	0.5	10.3	12.5	11.5	6.9	6.9
Turbidity	NTU	Narrative	0.1	2.9	1.9	1.7	1.7	1.3
Calculated Parameters								
Bicarbonate Alkalinity	mg/L	-	5	30	39	24	20	21
Carbonate Alkalinity	mg/L	-	10	<10	<10	<10	<10	<10
Hydroxide	mg/L	-	5	<5	<5	<5	<5	<5
Cation sum	meq/L	-	-	0.78	1.00	0.70	0.62	0.60
Anion sum	meq/L	-	-	0.72	0.89	0.59	0.54	0.56
% difference	%	-	-	4.1	5.6	7.9	6.5	3.7
Hardness	mg/L	-	-	30.0	39.8	25.7	21.8	21.3
Saturation pH (@ 20C)	-	-	-	9.12	8.86	9.28	9.39	9.39
Saturation pH (@ 4C)	-	-	-	9.44	9.18	9.60	9.71	9.71
Langelier Index (@ 20C)	-	-	-	-1.68	-1.52	-1.97	-2.03	-1.99
Langelier Index (@ 4C)	-	-	-	-2.00	-1.84	-2.29	-2.35	-2.31
True Color	TCU	Narrative	5	58	51	53	18	13
Kjeldahl Nitrogen	mg/L	-	0.4	1.1	0.6	0.6	1	0.6
Total Dissolved Solids	mg/L	-	1	37	47	32	29	30
Total Suspended Solids	mg/L	Narrative	5	<5	<5	<5	<5	<5

Collection of samples conducted by GEMTEC Ltd and analysis provided by AGAT Laboratories.

Notes:

1. CCME FWAL = CCME Canadian Water Quality Guidelines for the Protection of Freshwater Aquatic Life Summary Table (CCME, 2015).
2. RDL = Reported Detection Limit.
3. Guideline is pH and temperature-dependent.

4. Short-Term Exposure, Long-Term Exposure.

DUP - Field duplicate taken at SW4.

"-" = None established/ not measured.

Results that exceed the guideline are bold and shaded.

Table H2: Total Metals, Surface Water

Sample Station:	Units	CCME FWAL ¹	RDL ²	SW-1	SW-2	SW-3	SW-4	SW-4A (DUP)
Date Sampled:				07-Jul-17	07-Jul-17	07-Jul-17	07-Jul-17	07-Jul-17
Aluminium	µg/L	100 ³	5	102	57	79	38	39
Antimony	µg/L	-	2	<2	<2	<2	<2	<2
Arsenic	µg/L	5	2	2	<2	<2	<2	<2
Barium	µg/L	-	5	<5	<5	<5	<5	<5
Beryllium	µg/L	-	2	<2	<2	<2	<2	<2
Bismuth	µg/L	-	2	<2	<2	<2	<2	<2
Boron	µg/L	29000 ⁷ , 1500 ⁷	5	<5	<5	<5	<5	<5
Cadmium	µg/L	1.0 ⁷ , 0.09 ⁷	0.017	<0.017	<0.017	<0.017	<0.017	<0.017
Chromium	µg/L	-	1	1	1	1	<1	<1
Cobalt	µg/L	-	1	<1	<1	<1	<1	<1
Copper	µg/L	2 ⁴	1	<1	<1	<1	1	<1
Iron	µg/L	300	50	84	97	116	114	108
Lead	µg/L	1 ⁵	0.5	<0.5	<0.5	<0.5	<0.5	<0.5
Manganese	µg/L	-	2	<2	4	3	7	6
Mercury	µg/L	0.026	0.026	<0.026	<0.026	<0.026	<0.026	<0.026
Molybdenum	µg/L	73	2	<2	<2	<2	<2	<2
Nickel	µg/L	25 ⁶	2	<2	<2	<2	<2	<2
Selenium	µg/L	1	1	<1	<1	<1	<1	<1
Silver	µg/L	0.25	0.1	<0.1	<0.1	<0.1	<0.1	<0.1
Strontium	µg/L	-	5	20.0	25	18	11	11
Thallium	µg/L	0.8	0.1	<0.1	<0.1	<0.1	<0.1	<0.1
Tin	µg/L	-	2	<2	<2	<2	<2	<2
Titanium	µg/L	-	2	<2	<2	<2	<2	<2
Uranium	µg/L	33 ⁷ , 15 ⁷	0.1	<0.1	<0.1	<0.1	<0.1	<0.1
Vanadium	µg/L	-	2	<2	<2	<2	<2	<2
Zinc	µg/L	30	5	<5	<5	<5	<5	<5

Collection of samples conducted by GEMTEC Ltd and analysis provided by AGAT Laboratories

Notes:

- 1- CCME FWAL = CCME Canadian Water Quality Guidelines for the Protection of Freshwater Aquatic Life Summary Table (CCME, 2015).
 - 2- RDL = Reported Detection Limit.
 - 3 - Aluminum guideline = 5 µg/L at pH<6.5, or 100 µg/L at pH>=6.5
 - 4 - Copper guideline [µg/L], for water hardness between 82 and 180 mg/L as CaCO₃; If water hardness is <82, guideline = 2; If water hardness is >180, guideline = 4; If water hardness is unknown, guideline = 2
 - 5 - Lead guideline [µg/L], for water hardness between 60 and 180 mg/L as CaCO₃; If water hardness is less than 60, guideline = 1; If water hardness is greater than 180, guideline = 7; If water hardness is unknown, guideline = 1
 - 6 - Nickel guideline [µg/L], for water hardness between 0 and 60 as CaCO₃, guideline = 25. Long Term Exposure
 - 7 -Short-Term Exposure, Long-Term Exposure.
- DUP - Field duplicate taken at SW4.

Results that exceed the guideline are bold and shaded.

Appendix I
Laboratory Certificates of Analysis

CLIENT NAME: GEMTEC LIMITED
10 Maverick Place
Paradise, NL A1L 1Y8
709722-2275

ATTENTION TO: Darrol Rice

PROJECT: 80016.09

AGAT WORK ORDER: 17X235130

WATER ANALYSIS REVIEWED BY: Laura Baker, Inorganics Data Reporter

DATE REPORTED: Jul 18, 2017

PAGES (INCLUDING COVER): 9

VERSION*: 1

Should you require any information regarding this analysis please contact your client services representative at (902) 468-8718

***NOTES**

All samples will be disposed of within 30 days following analysis. Please contact the lab if you require additional sample storage time.



Certificate of Analysis

AGAT WORK ORDER: 17X235130

PROJECT: 80016.09

11 Morris Drive, Unit 122
Dartmouth, Nova Scotia
CANADA B3B 1M2
TEL (902)468-8718
FAX (902)468-8924
<http://www.agatlabs.com>

CLIENT NAME: GEMTEC LIMITED

ATTENTION TO: Darrol Rice

SAMPLING SITE:

SAMPLED BY:

Mercury Analysis in Water (Total)

DATE RECEIVED: 2017-07-10

DATE REPORTED: 2017-07-18

Parameter	Unit	SAMPLE DESCRIPTION:		SW-1	SW-2	SW-3	SW-4	SW-4A
		G / S	RDL	Water	Water	Water	Water	Water
DATE SAMPLED:		2017-07-07	2017-07-07	2017-07-07	2017-07-07	2017-07-07	2017-07-07	2017-07-07
Total Mercury	ug/L	0.026	<0.026	<0.026	<0.026	<0.026	<0.026	<0.026

Comments: RDL - Reported Detection Limit; G / S - Guideline / Standard

Certified By:



Certificate of Analysis

AGAT WORK ORDER: 17X235130

PROJECT: 80016.09

11 Morris Drive, Unit 122
 Dartmouth, Nova Scotia
 CANADA B3B 1M2
 TEL (902)468-8718
 FAX (902)468-8924
<http://www.agatlabs.com>

CLIENT NAME: GEMTEC LIMITED

ATTENTION TO: Darrol Rice

SAMPLING SITE:

SAMPLED BY:

Standard Water Analysis + Total Metals

DATE RECEIVED: 2017-07-10

DATE REPORTED: 2017-07-18

Parameter	Unit	SAMPLE DESCRIPTION:		SW-1	SW-2	SW-3	SW-4	SW-4A
		SAMPLE TYPE:		Water	Water	Water	Water	Water
		DATE SAMPLED:		2017-07-07	2017-07-07	2017-07-07	2017-07-07	2017-07-07
		G / S	RDL	8539235	8539238	8539240	8539241	8539243
pH				7.44	7.34	7.31	7.36	7.40
Reactive Silica as SiO2	mg/L		0.5	<0.5	0.6	<0.5	<0.5	<0.5
Chloride	mg/L		1	4	4	4	5	5
Fluoride	mg/L		0.12	<0.12	<0.12	<0.12	<0.12	<0.12
Sulphate	mg/L		2	<2	<2	<2	<2	<2
Alkalinity	mg/L		5	30	39	24	20	21
True Color	TCU		5	58	51	53	18	13
Turbidity	NTU		0.1	2.9	1.9	1.7	1.7	1.3
Electrical Conductivity	umho/cm		1	74	94	62	58	59
Nitrate + Nitrite as N	mg/L		0.05	0.07	<0.05	<0.05	<0.05	<0.05
Nitrate as N	mg/L		0.05	0.07	<0.05	<0.05	<0.05	<0.05
Nitrite as N	mg/L		0.05	<0.05	<0.05	<0.05	<0.05	<0.05
Ammonia as N	mg/L		0.03	<0.03	<0.03	<0.03	<0.03	<0.03
Total Organic Carbon	mg/L		0.5	10.3	12.5	11.5	6.9	6.9
Ortho-Phosphate as P	mg/L		0.01	<0.01	<0.01	<0.01	<0.01	<0.01
Total Sodium	mg/L		0.1	3.7	4.3	3.8	3.9	3.8
Total Potassium	mg/L		0.1	0.1	0.2	0.1	0.1	0.2
Total Calcium	mg/L		0.1	8.9	12.8	7.5	6.9	6.7
Total Magnesium	mg/L		0.1	1.9	1.9	1.7	1.1	1.1
Bicarb. Alkalinity (as CaCO3)	mg/L		5	30	39	24	20	21
Carb. Alkalinity (as CaCO3)	mg/L		10	<10	<10	<10	<10	<10
Hydroxide	mg/L		5	<5	<5	<5	<5	<5
Calculated TDS	mg/L		1	37	47	32	29	30
Hardness	mg/L			30.0	39.8	25.7	21.8	21.3
Langelier Index (@20C)	NA			-1.68	-1.52	-1.97	-2.03	-1.99
Langelier Index (@ 4C)	NA			-2.00	-1.84	-2.29	-2.35	-2.31
Saturation pH (@ 20C)	NA			9.12	8.86	9.28	9.39	9.39
Saturation pH (@ 4C)	NA			9.44	9.18	9.60	9.71	9.71
Anion Sum	me/L			0.72	0.89	0.59	0.54	0.56
Cation sum	me/L			0.78	1.00	0.70	0.62	0.60

Certified By:



Certificate of Analysis

AGAT WORK ORDER: 17X235130

PROJECT: 80016.09

11 Morris Drive, Unit 122
 Dartmouth, Nova Scotia
 CANADA B3B 1M2
 TEL (902)468-8718
 FAX (902)468-8924
<http://www.agatlabs.com>

CLIENT NAME: GEMTEC LIMITED

ATTENTION TO: Darrol Rice

SAMPLING SITE:

SAMPLED BY:

Standard Water Analysis + Total Metals

DATE RECEIVED: 2017-07-10

DATE REPORTED: 2017-07-18

Parameter	Unit	SAMPLE DESCRIPTION:		SW-1	SW-2	SW-3	SW-4	SW-4A
		SAMPLE TYPE:		Water	Water	Water	Water	Water
		DATE SAMPLED:		2017-07-07	2017-07-07	2017-07-07	2017-07-07	2017-07-07
		G / S	RDL	8539235	8539238	8539240	8539241	8539243
% Difference/ Ion Balance (NS)	%			4.1	5.6	7.9	6.5	3.7
Total Aluminum	ug/L		5	102	57	79	38	39
Total Antimony	ug/L		2	<2	<2	<2	<2	<2
Total Arsenic	ug/L		2	2	<2	<2	<2	<2
Total Barium	ug/L		5	<5	<5	<5	<5	<5
Total Beryllium	ug/L		2	<2	<2	<2	<2	<2
Total Bismuth	ug/L		2	<2	<2	<2	<2	<2
Total Boron	ug/L		5	<5	<5	<5	<5	<5
Total Cadmium	ug/L		0.017	<0.017	<0.017	<0.017	<0.017	<0.017
Total Chromium	ug/L		1	1	1	1	<1	<1
Total Cobalt	ug/L		1	<1	<1	<1	<1	<1
Total Copper	ug/L		1	<1	<1	<1	1	<1
Total Iron	ug/L		50	84	97	116	114	108
Total Lead	ug/L		0.5	<0.5	<0.5	<0.5	<0.5	<0.5
Total Manganese	ug/L		2	<2	4	3	7	6
Total Molybdenum	ug/L		2	<2	<2	<2	<2	<2
Total Nickel	ug/L		2	<2	<2	<2	<2	<2
Total Phosphorous	mg/L		0.02	0.03	0.03	0.03	0.03	0.02
Total Selenium	ug/L		1	<1	<1	<1	<1	<1
Total Silver	ug/L		0.1	<0.1	<0.1	<0.1	<0.1	<0.1
Total Strontium	ug/L		5	20	25	18	11	11
Total Thallium	ug/L		0.1	<0.1	<0.1	<0.1	<0.1	<0.1
Total Tin	ug/L		2	<2	<2	<2	<2	<2
Total Titanium	ug/L		2	<2	<2	<2	<2	<2
Total Uranium	ug/L		0.1	<0.1	<0.1	<0.1	<0.1	<0.1
Total Vanadium	ug/L		2	<2	<2	<2	<2	<2
Total Zinc	ug/L		5	<5	<5	<5	<5	<5

Comments: RDL - Reported Detection Limit; G / S - Guideline / Standard

Certified By:

Quality Assurance

CLIENT NAME: GEMTEC LIMITED
AGAT WORK ORDER: 17X235130
PROJECT: 80016.09
ATTENTION TO: Darrol Rice
SAMPLING SITE:
SAMPLED BY:

Water Analysis															
RPT Date: Jul 18, 2017			DUPLICATE				Method Blank	REFERENCE MATERIAL			METHOD BLANK SPIKE			MATRIX SPIKE	
PARAMETER	Batch	Sample Id	Dup #1	Dup #2	RPD	Measured Value		Acceptable Limits		Recovery	Acceptable Limits		Recovery	Acceptable Limits	
								Lower	Upper		Lower	Upper		Lower	Upper

Standard Water Analysis + Total Metals

pH	8539994		8.03	8.02	0.1%	<	106%	80%	120%	NA	80%	120%	NA	80%	120%
Reactive Silica as SiO2	1	8537124	4.5	4.7	4.3%	< 0.5	106%	80%	120%		80%	120%	90%	80%	120%
Chloride	8539235	8539235	4	4	NA	< 1	91%	80%	120%	NA	80%	120%	95%	80%	120%
Fluoride	8539235	8539235	<0.12	<0.12	NA	< 0.12	91%	80%	120%	NA	80%	120%	119%	80%	120%
Sulphate	8539235	8539235	<2	<2	NA	< 2	108%	80%	120%	NA	80%	120%	98%	80%	120%
Alkalinity	8539994		126	126	0.0%	< 5	89%	80%	120%	NA	80%	120%	NA	80%	120%
True Color	1	8539243	12	13	NA	< 5	80%	80%	120%						
Turbidity	1	8539243	1.1	1.3	16.7%	< 0.1	103%	80%	120%						
Electrical Conductivity	8539994		289	288	0.4%	< 1	100%	80%	120%	NA	80%	120%	NA	80%	120%
Nitrate as N	8539235	8539235	0.07	<0.05	NA	< 0.05	93%	80%	120%	NA	80%	120%	86%	80%	120%
Nitrite as N	8539235	8539235	<0.05	<0.05	NA	< 0.05	97%	80%	120%	NA	80%	120%	99%	80%	120%
Ammonia as N	1	8537124	<0.03	<0.03	NA	< 0.03	109%	80%	120%		80%	120%	106%	80%	120%
Total Organic Carbon	1	8529409	5.3	5.3	0.0%	< 0.5	105%	80%	120%		80%	120%	98%	80%	120%
Ortho-Phosphate as P	1	8537124	<0.01	<0.01	NA	< 0.01	102%	80%	120%		80%	120%	99%	80%	120%
Total Sodium	8540966		65.3	72.0	9.8%	< 0.1	107%	80%	120%	105%	80%	120%	NA	70%	130%
Total Potassium	8540966		<0.1	<0.1	NA	< 0.1	104%	80%	120%	101%	80%	120%	91%	70%	130%
Total Calcium	8540966		0.2	<0.1	NA	< 0.1	98%	80%	120%	96%	80%	120%	83%	70%	130%
Total Magnesium	8540966		<0.1	<0.1	NA	< 0.1	104%	80%	120%	103%	80%	120%	99%	80%	120%
Bicarb. Alkalinity (as CaCO3)	8539994		126	126	0.0%	< 5	NA	80%	120%	NA	80%	120%	NA	80%	120%
Carb. Alkalinity (as CaCO3)	8539994		<10	<10	NA	< 10	NA	80%	120%	NA	80%	120%	NA	80%	120%
Hydroxide	8539994		<5	<5	NA	< 5	NA	80%	120%	NA	80%	120%	NA	80%	120%
Total Aluminum	8540966		<5	<5	NA	< 5	103%	80%	120%	103%	80%	120%	93%	70%	130%
Total Antimony	8540966		<2	<2	NA	< 2	93%	80%	120%	86%	80%	120%	90%	70%	130%
Total Arsenic	8540966		<2	<2	NA	< 2	98%	80%	120%	94%	80%	120%	97%	70%	130%
Total Barium	8540966		<5	<5	NA	< 5	96%	80%	120%	93%	80%	120%	95%	70%	130%
Total Beryllium	8540966		<2	<2	NA	< 2	106%	80%	120%	103%	80%	120%	106%	70%	130%
Total Bismuth	8540966		<2	<2	NA	< 2	101%	80%	120%	103%	80%	120%	102%	70%	130%
Total Boron	8540966		16	16	NA	< 5	101%	80%	120%	95%	80%	120%	115%	70%	130%
Total Cadmium	8540966		<0.017	<0.017	NA	< 0.017	97%	80%	120%	96%	80%	120%	95%	70%	130%
Total Chromium	8540966		<1	<1	NA	< 1	101%	80%	120%	97%	80%	120%	107%	70%	130%
Total Cobalt	8540966		<1	<1	NA	< 1	100%	80%	120%	97%	80%	120%	113%	70%	130%
Total Copper	8540966		13	12	10.0%	< 1	99%	80%	120%	98%	80%	120%	NA	70%	130%
Total Iron	8540966		57	56	NA	< 50	96%	80%	120%	93%	80%	120%	110%	70%	130%
Total Lead	8540966		1.0	<0.5	NA	< 0.5	107%	80%	120%	102%	80%	120%	100%	70%	130%
Total Manganese	8540966		2	<2	NA	< 2	95%	80%	120%	94%	80%	120%	102%	70%	130%
Total Molybdenum	8540966		<2	<2	NA	< 2	93%	80%	120%	91%	80%	120%	104%	70%	130%
Total Nickel	8540966		<2	<2	NA	< 2	102%	80%	120%	96%	80%	120%	110%	70%	130%
Total Phosphorous	8540966		<0.02	<0.02	NA	< 0.02	117%	80%	120%	105%	80%	120%	99%	70%	130%
Total Selenium	8540966		<1	<1	NA	< 1	102%	80%	120%	94%	80%	120%	83%	70%	130%

Quality Assurance

CLIENT NAME: GEMTEC LIMITED
AGAT WORK ORDER: 17X235130
PROJECT: 80016.09
ATTENTION TO: Darrol Rice
SAMPLING SITE:
SAMPLED BY:

Water Analysis (Continued)

RPT Date: Jul 18, 2017			DUPLICATE				Method Blank	REFERENCE MATERIAL			METHOD BLANK SPIKE			MATRIX SPIKE		
PARAMETER	Batch	Sample Id	Dup #1	Dup #2	RPD	Measured Value		Acceptable Limits		Recovery	Acceptable Limits		Recovery	Acceptable Limits		
								Lower	Upper		Lower	Upper		Lower	Upper	
Total Silver	8540966		<0.1	<0.1	NA	< 0.1	90%	80%	120%	95%	80%	120%	103%	70%	130%	
Total Strontium	8540966		<5	<5	NA	< 5	92%	80%	120%	89%	80%	120%	100%	70%	130%	
Total Thallium	8540966		<0.1	<0.1	NA	< 0.1	105%	80%	120%	105%	80%	120%	110%	70%	130%	
Total Tin	8540966		<2	<2	NA	< 2	97%	80%	120%	95%	80%	120%	96%	70%	130%	
Total Titanium	8540966		<2	<2	NA	< 2	104%	80%	120%	102%	80%	120%	92%	70%	130%	
Total Uranium	8540966		<0.1	<0.1	NA	< 0.1	99%	80%	120%	98%	80%	120%	111%	70%	130%	
Total Vanadium	8540966		<2	<2	NA	< 2	95%	80%	120%	93%	80%	120%	110%	70%	130%	
Total Zinc	8540966		22	22	NA	< 5	101%	80%	120%	97%	80%	120%	105%	70%	130%	

Comments: If RPD value is NA, the results of the duplicates are less than 5x the RDL and the RPD will not be calculated.

Certified By:



Method Summary

CLIENT NAME: GEMTEC LIMITED

AGAT WORK ORDER: 17X235130

PROJECT: 80016.09

ATTENTION TO: Darrol Rice

SAMPLING SITE:

SAMPLED BY:

PARAMETER	AGAT S.O.P	LITERATURE REFERENCE	ANALYTICAL TECHNIQUE
Water Analysis			
Total Mercury	MET-121-6100 & MET-121-6107	SM 3112 B	CV/AA
pH	INOR-121-6001	SM 4500 H+B	PC TITRATE
Reactive Silica as SiO ₂	INORG-121-6028	SM 4110 B	COLORIMETER
Chloride	INORG-121-6005	SM 4110 B	ION CHROMATOGRAPH
Fluoride	INORG-121-6005	SM 4110 B	ION CHROMATOGRAPH
Sulphate	INORG-121-6005	SM 4110 B	ION CHROMATOGRAPH
Alkalinity	INORG-121-6001	SM 2320 B	
True Color	INORG-121-6014	EPA 110.2	NEPHELOMETER
Turbidity	INORG-121-6022	SM 2130 B	NEPHELOMETER
Electrical Conductivity	INOR-121-6001	SM 2510 B	PC TITRATE
Nitrate + Nitrite as N	INORG-121-6005	SM 4110 B	CALCULATION
Nitrate as N	INORG-121-6005	SM 4110 B	ION CHROMATOGRAPH
Nitrite as N	INORG-121-6005	SM 4110 B	ION CHROMATOGRAPH
Ammonia as N	INORG-121-6003	SM 4500-NH ₃ G	COLORIMETER
Total Organic Carbon	INORG-121-6026	SM 5310 B	TOC ANALYZER
Ortho-Phosphate as P	INORG-121-6005	SM 4110 B	COLORIMETER
Total Sodium	MET121-6104 & MET-121-6105	SM 3125	ICP-MS
Total Potassium	MET121-6104 & MET-121-6105	SM 3125	ICP-MS
Total Calcium	MET121-6104 & MET-121-6105	SM 3125	ICP-MS
Total Magnesium	MET121-6104 & MET-121-6105	SM 3125	ICP-MS
Bicarb. Alkalinity (as CaCO ₃)	INORG-121-6001	SM 2320 B	PC TITRATE
Carb. Alkalinity (as CaCO ₃)	INORG-121-6001	SM 2320 B	PC TITRATE
Hydroxide	INORG-121-6001	SM 2320 B	PC-TITRATE
Calculated TDS	CALCULATION	SM 1030E	CALCULATION
Hardness	CALCULATION	SM 2340B	CALCULATION
Langelier Index (@20C)	CALCULATION	CALCULATION	CALCULATION
Langelier Index (@ 4C)	CALCULATION	CALCULATION	CALCULATION
Saturation pH (@ 20C)	CALCULATION	CALCULATION	CALCULATION
Saturation pH (@ 4C)	CALCULATION	CALCULATION	CALCULATION
Anion Sum	CALCULATION	SM 1030E	CALCULATION
Cation sum	CALCULATION	SM 1030E	CALCULATION
% Difference/ Ion Balance (NS)	CALCULATION	SM 1030E	CALCULATION
Total Aluminum	MET121-6104 & MET-121-6105	SM 3125	ICP-MS
Total Antimony	MET121-6104 & MET-121-6105	SM 3125	ICP-MS
Total Arsenic	MET121-6104 & MET-121-6105	SM 3125	ICP-MS
Total Barium	MET121-6104 & MET-121-6105	SM 3125	ICP-MS
Total Beryllium	MET121-6104 & MET-121-6105	SM 3125	ICP-MS
Total Bismuth	MET121-6104 & MET-121-6105	SM 3125	ICP-MS
Total Boron	MET121-6104 & MET-121-6105	SM 3125	ICP-MS



Method Summary

CLIENT NAME: GEMTEC LIMITED

AGAT WORK ORDER: 17X235130

PROJECT: 80016.09

ATTENTION TO: Darrol Rice

SAMPLING SITE:

SAMPLED BY:

PARAMETER	AGAT S.O.P	LITERATURE REFERENCE	ANALYTICAL TECHNIQUE
Total Cadmium	MET121-6104 & MET-121-6105	SM 3125	ICP-MS
Total Chromium	MET121-6104 & MET-121-6105	SM 3125	ICP-MS
Total Cobalt	MET121-6104 & MET-121-6105	SM 3125	ICP-MS
Total Copper	MET121-6104 & MET-121-6105	SM 3125	ICP-MS
Total Iron	MET121-6104 & MET-121-6105	SM 3125	ICP-MS
Total Lead	MET121-6104 & MET-121-6105	SM 3125	ICP-MS
Total Manganese	MET121-6104 & MET-121-6105	SM 3125	ICP-MS
Total Molybdenum	MET121-6104 & MET-121-6105	SM 3125	ICP-MS
Total Nickel	MET121-6104 & MET-121-6105	SM 3125	ICP-MS
Total Phosphorous	MET-121-6104 & MET-121-6105	SM 3125	ICP-MS
Total Selenium	MET121-6104 & MET-121-6105	SM 3125	ICP-MS
Total Silver	MET121-6104 & MET-121-6105	SM 3125	ICP-MS
Total Strontium	MET121-6104 & MET-121-6105	SM 3125	ICP-MS
Total Thallium	MET121-6104 & MET-121-6105	SM 3125	ICP-MS
Total Tin	MET121-6104 & MET-121-6105	SM 3125	ICP-MS
Total Titanium	MET121-6104 & MET-121-6105	SM 3125	ICP-MS
Total Uranium	MET121-6104 & MET-121-6105	SM 3125	ICP-MS
Total Vanadium	MET121-6104 & MET-121-6105	SM 3125	ICP-MS
Total Zinc	MET121-6104 & MET-121-6105	SM 3125	ICP-MS



Laboratories

Unit 122 • 11 Morris Drive
Dartmouth, NS
B3B 1M2
webearth.agatlabs.com • www.agatlabs.com

Chain of Custody Record

Report Information

Company: Gentec
 Contact: Darrol Rice
 Address: 10 Maverick Place
Paradise, NL
 Phone: 722-2275 Fax: 80016.09
 Client Project #: 80016.09
 AGAT Quotation: _____
 Please Note: If quotation number is not provided client will be billed full price for analysis.

Invoice To

Company: _____
 Contact: _____
 Address: _____
 Phone: _____ Fax: _____
 PO/Credit Card#: _____

Report Information (Please print):

1. Name: Darrol Rice
 Email: darrol.rice@gentec.ca
 2. Name: _____
 Email: _____

Regulatory Requirements (Check):

List Guidelines on Report Do not list Guidelines on Report
 PIRI
 Tier 1 Res Pot Coarse
 Tier 2 Com N/Pot Fine
 Gas Fuel Lube
 CCME CDWQ Industrial NSESQ-Cont. Sites
 Commercial HRM 101
 Res/Park Storm Water
 Agricultural Waste Water
 FWAL Sediment Other _____

Report Format

Single Sample per page
 Multiple Samples per page
 Excel Format Included

Drinking Water Sample:

Yes No
 Reg. No.: _____

Laboratory Use Only

Arrival Condition: Good Poor (see notes)
 Arrival Temperature: 7.8
 Hold Time: _____
 AGAT Job Number: 17235130

Notes:

Notes: _____

Turnaround Time Required (TAT)

Regular TAT 5 to 7 working days
 Same day 1 day
 Rush TAT 2 days 3 days
 Date Required: _____

Field Filtered/Preserved	
Standard Water Analysis	
Metals: Total <input type="checkbox"/> Diss <input type="checkbox"/> Available	
Mercury	
<input type="checkbox"/> BOD <input type="checkbox"/> CBOD	
<input type="checkbox"/> pH	
<input type="checkbox"/> TSS <input type="checkbox"/> TDS <input type="checkbox"/> VSS	
TKN	
Total Phosphorus	
Phenols	
Tier 1: TPH/BTEX (PRI) <input type="checkbox"/> low level	
Tier 2: TPH/BTEX Fractionation	
CCME-CWS TPH/BTEX	
VOC	
THM	
HAA	
PAH	
PCB	
TC + EC <input type="checkbox"/> P/A <input type="checkbox"/> MPN <input type="checkbox"/> MF	
HPC <input type="checkbox"/> Pseudomonas	
Fecal Coliform <input type="checkbox"/> MPN <input type="checkbox"/> MF	
Other:	
Other:	
Hazardous (Y/N)	

Sample Identification	Date/Time Sampled	Sample Matrix	# Containers	Comments - Site/Sample Info. Sample Containment
SW-1	July 7 2017	SW	3	
SW-2				
SW-3				
SW-4				
SW-4A				

Samples Relinquished By (Print Name): <u>Darrol Rice</u>	Date/Time: <u>July 10/17</u>	Samples Received By (Print Name): <u>Justin Gels</u>	Date/Time: <u>July 10/17</u>	Pink Copy - Client
Samples Relinquished By (Sign): <u>Darrol Rice</u>	Date/Time: <u>July 10/17</u>	Samples Received By (Sign): <u>Justin Gels</u>	Date/Time: <u>July 10/17</u>	Yellow Copy - AGAT
				White Copy - AGAT
				Page <input type="checkbox"/> of <input type="checkbox"/>
				No: 053113

Appendix B

Acid Rock Drainage (ARD) Testing

Final Report

ARD Testing of Argyle Material; Anaconda Mining Inc.

Reference No.: MIS-J2051

Prepared for:

Ms. Gordana Slepcev and Mr. Jordan Cramm
Anaconda Mining Inc.
Pine Cove Mine
Baie Verte, NL A0K 1B0

September 19, 2017

Prepared by:



Neri Botha, P.Eng.
Extractive Metallurgist
Minerals & Industrial Services

Reviewed by:

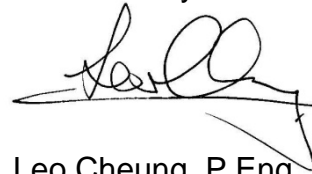

Leo Cheung, P.Eng.
Department Head
Minerals & Industrial Services

INTRODUCTION

Anaconda Mining Inc. initiated a study at RPC to conduct static Acid Rock Drainage (ARD) test work. The Argyle deposit being investigated by Anaconda Mining Inc. in conjunction with RPC to look at ways of expanding current operations.

RPC was thus contacted to conduct static testing as follows:

- Acid Base Accounting (ABA by Sobek method)
- Total S analysis
- Sulphate S analysis
- Total inorganic carbon analysis
- Whole rock analysis
- Multi-element ICP-OES analysis
- Au by Fire Assay

This report serves to summarize the findings as well as recommendations for the way forward.

PROGRAM RESULTS

Sample Preparation

Twenty samples were received in preparation for the static testing. Each of these samples were respectively dried, crushed to $-1/4$ ", homogenized and split into sub samples for ABA, Total S, Total Inorganic Carbon, whole rock, Au by Fire Assay and multi-element ICP analyses. These samples were as laid out in Table 1.

Table 1
Argyle Samples Subjected to ARD Analysis

Sample #	Received Mass (kg)
AE-ARD-001	0.36
AE-ARD-002	0.26
AE-ARD-003	0.32
AE-ARD-004	0.38
AE-ARD-005	0.32
AE-ARD-006	0.24
AE-ARD-007	0.32
AE-ARD-008	0.34
AE-ARD-009	0.32
AE-ARD-010	0.28
AE-ARD-011	0.32
AE-ARD-012	0.40
AE-ARD-013	0.28
AE-ARD-014	0.26
AE-ARD-015	0.26
AE-ARD-016	0.28
AE-ARD-017	0.24
AE-ARD-018	0.32
AE-ARD-019	0.32
AE-ARD-020	0.46

Acid Rock Drainage (ARD) Static Analyses Results

The results from Total Inorganic Carbon analyses and acid-base accounting (utilizing the Sobek method) on the 20 samples submitted (see Table 1) are given in Table 2 to Table 3.

Table 2
Total Inorganic Carbon Analyses on Argyle Samples

Client ID	Total Inorganic Carbon
	%
AE-ARD-001	0.57
AE-ARD-002	0.09
AE-ARD-003	0.91
AE-ARD-004	0.11
AE-ARD-005	0.10
AE-ARD-006	0.44
AE-ARD-007	1.33
AE-ARD-008	0.36
AE-ARD-009	0.25
AE-ARD-010	0.58
AE-ARD-011	1.56
AE-ARD-012	1.72
AE-ARD-013	0.08
AE-ARD-014	0.27
AE-ARD-015	0.05
AE-ARD-016	0.29
AE-ARD-017	0.42
AE-ARD-018	0.28
AE-ARD-019	0.04
AE-ARD-020	0.42

Table 3
Acid Base Accounting Results on Argyle Samples

Client ID	Paste pH	Total Sulfur	Acid Production Potential	Neutralizing Potential pH 8.3	Net NP pH 8.3	NP/AP
		%	Kg CaCO ₃ /tonne			
AE-ARD-001	9.3	0.007	0.2	75.0	74.8	343
AE-ARD-002	8.9	0.151	4.7	71.0	66.3	15.0
AE-ARD-003	9.0	0.352	11.0	83.9	72.9	7.6
AE-ARD-004	9.2	0.077	2.4	17.0	14.6	7.1
AE-ARD-005	8.9	6.800	213	71.8	-141	0.3
AE-ARD-006	9.4	0.023	0.7	76.8	76.1	107
AE-ARD-007	9.3	0.075	2.3	91.4	89.1	39.0
AE-ARD-008	9.2	0.018	0.6	47.0	46.4	83.6
AE-ARD-009	9.0	1.610	50.3	74.7	24.4	1.5
AE-ARD-010	8.8	0.064	2.0	79.1	77.1	39.5
AE-ARD-011	9.3	0.085	2.7	94.7	92.0	35.6
AE-ARD-012	9.3	0.060	1.9	96.8	95.0	51.6
AE-ARD-013	9.2	0.158	4.9	10.7	5.8	2.2
AE-ARD-014	9.4	0.011	0.3	104	103	301
AE-ARD-015	9.0	0.229	7.2	42.2	35.0	5.9
AE-ARD-016	9.7	0.035	1.1	37.6	36.5	34.4
AE-ARD-017	8.9	0.134	4.2	77.2	73.0	18.4
AE-ARD-018	9.2	0.072	2.3	75.8	73.6	33.7
AE-ARD-019	9.1	0.021	0.7	16.2	15.5	24.6
AE-ARD-020	9.0	0.077	2.4	55.6	53.2	23.1

The Total Inorganic Carbon analyses seen in Table 2 indicated that the inorganic carbon content was relatively low over all 20 samples (ranging from 0.04 % to 1.72 % in sample # AE-ARD-012). In addition, the Total Sulfur contents of the 20 samples were also relatively low (see Table 3), ranging from 0.007 % to 1.610 % in sample # AE-ARD-009. Sample # AE-ARD-005 had a higher Total Sulfur content at 6.800 %.

As seen from Table 3, most of the Argyle samples obtained positive Net Neutralizing Potential values with NP/AP ratio values (ratio between Neutralizing Potential and Acid Production Potential) above 2.0. This indicated that these specific samples were not net acid producers. On sample # AE-ARD-005, the Net Neutralizing Potential value was negative and the NP/AP ratio was less than 1.0 at 0.3, indicating that this sample was potentially acid producing.

Sample # AE-ARD-009 obtained an NP/AP ratio value between 2.0 and 1.0 at 1.5 and was thus classified as “uncertain”.

It is recommended that a specialized consultant be contacted for the full MEND Report 1.20.1 analysis and interpretation prior to follow up with the regulatory agent.

The sulphate sulfur contents of the 20 samples were also determined and whole rock analyses as well as ICP multi-element analyses and Au Fire Assay analyses were conducted with the results reported in Table 4 to Table 8.

**Table 4
 Argyle Samples Sulphate S Analyses Results**

Sample	Wt. %	
	S (Total)	as SO ₄
AE-ARD-001	0.037	0.007
AE-ARD-002	0.139	0.005
AE-ARD-003	0.399	0.009
AE-ARD-004	0.046	0.004
AE-ARD-005	2.686	0.037
AE-ARD-006	0.038	0.004
AE-ARD-007	0.061	0.016
AE-ARD-008	0.037	0.006
AE-ARD-009	0.935	0.017
AE-ARD-010	0.075	0.002
AE-ARD-011	0.058	0.006
AE-ARD-012	0.046	0.011
AE-ARD-013	0.128	0.009
AE-ARD-014	0.037	0.004
AE-ARD-015	0.237	0.006
AE-ARD-016	0.039	0.003
AE-ARD-017	0.117	0.011
AE-ARD-018	0.124	0.005
AE-ARD-019	0.053	0.009
AE-ARD-020	0.068	0.006

Table 5
ICP Multi-Element Analyses Results on Argyle Samples # AE-ARD-001 to AE-ARD-010

Sample ID	AE-ARD-001	AE-ARD-002	AE-ARD-003	AE-ARD-004	AE-ARD-005	AE-ARD-006	AE-ARD-007	AE-ARD-008	AE-ARD-009	AE-ARD-010
Unit	(mg/kg)	(mg/kg)	(mg/kg)	(mg/kg)	(mg/kg)	(mg/kg)	(mg/kg)	(mg/kg)	(mg/kg)	(mg/kg)
Ag	<0.2	0.622	<0.2	<0.2	1.869	<0.2	<0.2	<0.2	0.768	<0.2
Al	71111	72858	66842	74131	81291	73772	72119	90807	67498	71326
As	2	4	29	5	116	<1	2	<1	62	<1
Ba	50	77	104	54	62	126	126	51	48	31
Be	0.9	1.7	1.4	0.9	1.4	1.1	0.8	0.9	1.2	1.5
Bi	<5	<5	<5	<5	<5	<5	<5	<5	<5	<5
Ca	37647	33881	76016	56336	28202	62262	57364	23704	43033	41499
Cd	<5	<5	<5	<5	<5	<5	<5	<5	<5	<5
Ce	43	93	38	42	105	35	41	37	95	97
Co	34	25	54	45	17	49	35	34	27	43
Cr	349	50	28	126	47	87	165	176	65	28
Cu	37	3	<1	74	41	30	51	1	6	6
Fe	45559	75421	70938	76637	65357	75307	74268	51809	56931	91895
Ga	6	13	12	10	10	10	<5	9	12	14
Ge	<10	<10	<10	<10	12.945	<10	<10	<10	<10	11.578
In	11	11	14	12	12	16	8	9	12	16
K	4562	8036	13922	2840	6882	13954	5136	3411	6524	2939
La	10	19	5	4	26	2	5	7	21	17
Li	16	4	3	7	2	14	25	18	3	12
Mg	52171	13207	19759	35296	9211	32475	35841	49686	11545	20608
Mn	1047	1968	2044	1553	1239	1695	4188	1036	1685	1653
Mo	<1	1.325	1.399	1.019	2.931	<1	<1	<1	1.814	1.806
Na	25010	32649	16067	27260	47932	14302	19644	39243	34606	23640
Nb	22	25	53	46	31	54	39	23	28	47
Ni	161	5	11	38	3	26	28	60	1	2
P	776	3676	1191	877	1225	785	1170	679	2944	2757
Pb	<5	<5	<5	<5	8	<5	<5	<5	<5	<5
S	143	1468	4530	380	32854	182	284	129	11386	533
Sb	15	<10	<10	<10	<10	<10	<10	<10	<10	<10
Se	<5	<5	<5	<5	<5	<5	<5	<5	<5	<5
Sn	<2	<2	<2	<2	<2	<2	<2	<2	<2	<2
Sr	147	163	202	294	155	192	195	158	143	154
Ta	<5	6	22	14	7	18	12	7	8	15
Te	<10	<10	<10	<10	<10	<10	<10	<10	<10	<10
Ti	4869	11186	24345	11092	6549	13584	11771	6914	9354	16579
Tl	<5	<5	<5	<5	<5	<5	<5	<5	<5	<5
V	158	144	425	334	126	405	297	199	141	303
W	<2	<2	21	<2	9	4	<2	<2	7	3
Zn	52	74	72	77	52	63	46	50	45	68
Zr	84	381	215	132	601	108	137	105	410	380

Table 6
ICP Multi-Element Analyses Results on Argyle Samples # AE-ARD-011 to AE-ARD-020

Sample ID	AE-ARD-011	AE-ARD-012	AE-ARD-013	AE-ARD-014	AE-ARD-015	AE-ARD-016	AE-ARD-017	AE-ARD-018	AE-ARD-019	AE-ARD-020
Unit	(mg/kg)	(mg/kg)	(mg/kg)	(mg/kg)	(mg/kg)	(mg/kg)	(mg/kg)	(mg/kg)	(mg/kg)	(mg/kg)
Ag	<0.2	<0.2	<0.2	<0.2	<0.2	<0.2	<0.2	<0.2	<0.2	<0.2
Al	76713	75021	76873	66360	11713	73248	60895	62810	83213	76916
As	1	3	18	3	2	9	14	16	11	5
Ba	135	85	63	116	27	128	78	98	75	77
Be	0.7	0.9	1.3	1.3	0.3	1.2	1.2	1.2	1.1	1.3
Bi	<5	<5	<5	<5	<5	<5	<5	<5	<5	<5
Ca	84737	67911	55817	69879	12176	53341	51420	54095	55180	71479
Cd	<5	<5	<5	<5	<5	<5	6.17	<5	<5	<5
Ce	26	39	49	35	<10	43	77	69	48	35
Co	42	46	51	45	6	34	53	41	49	30
Cr	111	91	73	152	50	349	34	28	114	324
Cu	35	51	33	60	7	3	16	13	23	330
Fe	56801	68424	84171	63666	13348	47229	96079	73152	76929	46059
Ga	8	12	6	11	<5	<5	12	10	6	8
Ge	13.577	<10	<10	<10	<10	<10	<10	<10	<10	<10
In	10	13	17	14	5	10	19	13	14	9
K	9412	5461	1872	15027	3902	6322	12449	14079	1416	2980
La	2	5	6	4	<1	10	11	13	6	7
Li	10	15	10	8	<1	14	7	2	12	9
Mg	29690	27909	38308	29833	3555	50851	20124	17834	32251	39703
Mn	1019	1177	3016	1338	365	1702	1722	1965	3466	1642
Mo	<1	<1	<1	<1	1.13	<1	1.6	1.49	<1	<1
Na	22013	27277	23130	11808	2844	26616	7537	18618	25807	30397
Nb	39	44	44	39	<5	23	46	45	45	21
Ni	49	22	26	35	5	152	4	3	23	110
P	711	1116	1222	983	291	826	1928	1895	1112	585
Pb	<5	<5	<5	<5	5	<5	<5	<5	<5	7
S	571	395	1274	290	3172	220	1158	1467	382	691
Sb	<10	<10	<10	<10	<10	11	<10	<10	<10	11
Se	<5	<5	<5	<5	<5	<5	<5	<5	<5	<5
Sn	<2	<2	<2	<2	<2	<2	<2	<2	<2	<2
Sr	241	211	405	202	36	259	126	165	331	288
Ta	10	14	16	13	<5	8	19	19	15	<5
Te	<10	<10	<10	<10	<10	<10	<10	<10	<10	<10
Ti	8409	11905	12684	11164	772	4942	22238	18874	13008	4814
Tl	<5	<5	<5	<5	<5	<5	<5	<5	<5	<5
V	290	334	329	299	35	165	351	325	336	160
W	<2	<2	<2	5	<2	<2	5	9	<2	<2
Zn	76	50	74	64	21	61	110	69	71	130
Zr	105	139	199	127	25	76	298	317	169	93

Table 7
Argyle Samples Whole Rock Analyses Results

Sample	Wt. %															Total
	Al ₂ O ₃	CaO	Cr ₂ O ₃	Fe ₂ O ₃	K ₂ O	MgO	MnO	Na ₂ O	P ₂ O ₅	SiO ₂	SrO	TiO ₂	V ₂ O ₅	ZrO ₂	LOI 1000°C	
AE-ARD-001	14.28	5.60	0.05	6.92	0.58	9.19	0.14	3.59	0.19	49.97	0.02	0.86	0.03	0.01	8.35	99.79
AE-ARD-002	14.46	4.98	<0.01	11.32	1.02	2.30	0.27	4.63	0.88	48.33	0.02	1.96	0.03	0.05	9.58	99.83
AE-ARD-003	13.26	11.17	<0.01	10.65	1.76	3.44	0.28	2.28	0.29	37.04	0.03	4.27	0.10	0.03	14.91	99.51
AE-ARD-004	14.78	8.32	0.02	11.56	0.36	6.17	0.21	3.88	0.21	49.29	0.04	1.95	0.07	0.02	2.93	99.82
AE-ARD-005	16.12	4.14	<0.01	9.80	0.87	1.60	0.17	6.79	0.29	51.87	0.02	1.15	0.02	0.09	4.42	97.34
AE-ARD-006	14.71	9.20	0.01	11.36	1.77	5.68	0.23	2.04	0.19	36.98	0.02	2.39	0.08	0.02	15.28	99.98
AE-ARD-007	14.28	8.41	0.03	11.12	0.65	6.22	0.57	2.78	0.28	43.65	0.02	2.06	0.06	0.02	9.75	99.91
AE-ARD-008	17.81	3.44	0.03	7.69	0.43	8.55	0.14	5.50	0.16	48.22	0.02	1.20	0.04	0.01	6.53	99.75
AE-ARD-009	13.30	6.28	<0.01	8.49	0.82	2.00	0.23	4.87	0.70	53.43	0.02	1.63	0.03	0.06	6.96	98.81
AE-ARD-010	14.09	6.07	<0.01	13.73	0.37	3.57	0.22	3.33	0.66	47.35	0.02	2.89	0.06	0.05	7.45	99.87
AE-ARD-011	15.34	12.55	0.02	8.59	1.20	5.21	0.14	3.14	0.17	42.09	0.03	1.49	0.06	0.02	9.77	99.83
AE-ARD-012	14.76	9.90	0.01	10.19	0.69	4.82	0.16	3.83	0.27	42.66	0.03	2.07	0.07	0.02	10.35	99.81
AE-ARD-013	15.37	8.27	0.01	12.73	0.24	6.72	0.41	3.30	0.30	46.87	0.05	2.24	0.07	0.03	3.15	99.76
AE-ARD-014	13.20	10.30	0.02	9.58	1.91	5.21	0.18	1.68	0.24	39.53	0.03	1.96	0.06	0.02	16.04	99.95
AE-ARD-015	2.29	1.76	<0.01	1.98	0.49	0.61	0.05	0.40	0.07	89.48	<0.01	0.13	<0.01	<0.01	2.39	99.65
AE-ARD-016	14.50	7.82	0.05	7.07	0.80	8.83	0.23	3.76	0.20	51.76	0.03	0.86	0.03	0.01	3.94	99.92
AE-ARD-017	12.11	7.58	<0.01	14.46	1.58	3.51	0.23	1.07	0.47	42.97	0.02	3.91	0.08	0.04	11.78	99.81
AE-ARD-018	12.67	8.08	<0.01	11.17	1.81	3.16	0.27	2.68	0.46	42.25	0.02	3.36	0.07	0.05	13.71	99.78
AE-ARD-019	16.61	8.16	0.02	11.62	0.18	5.65	0.47	3.68	0.27	47.29	0.04	2.29	0.07	0.02	3.45	99.81
AE-ARD-020	15.19	10.46	0.05	6.88	0.38	6.88	0.22	4.29	0.14	49.90	0.04	0.84	0.03	0.01	4.33	99.64

Table 8
Argyle Samples Au Fire Assay Analyses Results

Sample	Grade
	Au (mg/kg)
AE-ARD-001	0.008
AE-ARD-002	0.141
AE-ARD-003	0.213
AE-ARD-004	0.026
AE-ARD-005	5.617
AE-ARD-006	<0.005
AE-ARD-007	0.006
AE-ARD-008	<0.005
AE-ARD-009	3.990
AE-ARD-010	0.055
AE-ARD-011	0.123
AE-ARD-012	0.012
AE-ARD-013	<0.005
AE-ARD-014	0.029
AE-ARD-015	0.816
AE-ARD-016	0.010
AE-ARD-017	0.018
AE-ARD-018	0.266
AE-ARD-019	<0.005
AE-ARD-020	0.017

CONCLUSIONS AND RECOMMENDATIONS

Note that all results were only as representative as the sample received. All data obtained were in good agreement with each other and showed that:

- Of the 20 Argyle samples subjected to static Acid Rock Drainage (ARD) testing, 1 was found (AE-ARD-005) to be potentially acid producing and 1 obtained an NP/AP ratio value between 2.0 and 1.0 (AE-ARD-009 was thus “uncertain”). The other 18 Argyle samples were all found to be not potentially acid producing.
- It was recommended that a specialized consultant be contacted for the full MEND Report 1.20.1 analysis and interpretation prior to follow up with the regulatory agent.

Appendix C

Consultation With the Town of Ming's Bight

Meeting Notes November 28, 2016

Representatives of Anaconda Mining met with the members of the Town Council of Ming's Bight on the evening of Monday, November 28, 2016. There is regular communication between the Town and Company both formal and informal.

The purpose of that meeting was twofold, to advise the Council regarding plans to continue exploration with the hopes of developing the Argyle project.

During that meeting representatives also provided an overview of the Point Rouse Project including the Port development as well as explained the opportunity for individuals to submit comments through the CEAA process.

A power point presentation document regarding the possible scope of the Argyle project was circulated and discussed.

Drilling had commenced and the Council said people could see the lights and occasionally hear the drill however there were no concerns expressed. One Councillor expressed that the drilling "sounds like job potential."

The issue of possible impact on the Town water supply was discussed with all parties agreeing that any development would follow environmental standards with the Company to be responsible for any accommodations that would need to be made.

Overall commentary from Town Council members regarding the Port Rouse Project very positive with every member of the Council having a personal or family employment connection to the local mining industry.

SUMMARY OF DISCUSSION FOR MING'S BIGHT TOWN COUNCIL PROJECTS UPDATE

On **December 4th, 2017** a discussion between the Ming's Bight Town Council and Anaconda Mining Inc. employees took place during the Town's regular Council meeting. The meeting was attended by Danny Regular (Mayor), Miles Regular (Deputy Mayor), Jamie Corbett (Councillor), xxx (Councillor), and Roxanne Dicks (Town Clerk/Manager). Anaconda Mining representatives included Anthony Chislett (Operations Manager), Jordan Cramm (Mine & Engineering Superintendent), and Mike Kelly (Exploration Geologist). The information session was scheduled for the purpose of sharing information associated with the Argyle and Stog'er Tigh projects with the town council and to address concerns and answer any immediate questions that they might have.

Jordan Cramm led the discussion with a presentation that discussed the following topics;

- **Stog'er Tigh Development**
 - 30,000 tonnes of ore mined to date
 - 2.5 years expected mine life at Stog'er Tigh will allow development time for Argyle
 - Mining the west pit first and then the east pit
 - Office facilities are in place
 - Presently dewatering Fox Pond (signage will be erected to warn of possible flood areas)
 - Fish passage will be constructed as per permitting requirement
 - Environmental Assessment process is complete
 - Settling pond is being constructed to provide environmental water control for pit dewatering
 - Overburden removal will take place and this material will be stockpiled for future rehabilitation requirements
 - A quarry permit will be necessary to allow shipping of waste materials if so desired
 - Stog'er Tigh mine is situated within the town boundaries of Baie Verte

- **Argyle Development and Exploration**
 - This is a new deposit discovered through soil surveys
 - Environmental Base line studies are complete
 - AMI will conduct additional drilling on the deposit to better outline the reserve
 - Project Description Registration (EA) to be completed
 - Resource calculation is in progress
 - Conceptual pit designs have been considered
 - This deposit falls within the Ming's Bight water shed area
 - Rock samples taken to date have indicated that the rock would not be acid generating. Measures will be in place to deal with water control and treatment if acid generation becomes evident (procedure to follow).
 - To date we have drilled 6500 meters of exploration holes (63 holes total)
 - Anaconda plans to ensure we define the resource to its fullest potential
 - The next milestone is to have a 3rd party define the resource for the NI 43-101 report which will be released in early 2018

- The impact on the water supply will have to be determined and mitigations measures considered
 - Our track record with governing authorities speaks for itself. We have demonstrated high regard for the environment in the past. Our employees are from the area and we all want to ensure we are held to the utmost environmentally friendly standards
 - Bonding will be put in place for the closure cost of the site. This work will be completed once the mine has been exhausted
 - Council asked if water sample results would be made available for their viewing considering that the mine is within their water shed area. We agreed that we could probably make the results public knowledge.
- Safety (Stog'er Tight and Argyle)
 - The close proximity of the town and the value of snowmobile/ATV accesses in the area will be considered to ensure that everyone is kept safe from harm during mining operations
 - Dust control especially in the water shed area is of utmost importance during operations
 - Noise control will also be given serious consideration
 - Anaconda uses a 500 meter radius for personnel and 300 meter radius for equipment when blasting. Special consideration will be given for the Argyle project due to its close proximity to the town of Ming's Bight. It will involve road closure and special signs and notices for the public.
 - NFLD Hard-Rok has extensive experience with blasting in close proximity to towns and other infrastructure
 - Snowmobile and ATV trails will need to be relocated to ensure safety of the travelling public
 - Public notices will be required to warn of dewatering in the Fox Pond area and potential negative effect on ice thicknesses and localized flooding
 - Access around Argyle will need to consider the town's water supply
- Future Mining Opportunities
 - With Pine Cove being mined out people are wondering what is next for Anaconda Mining Inc.
 - Anaconda has over 6400 hectares available for exploration on the Point Rouse project. There is potential in areas like;
 - Anaroc
 - Corkscrew
 - Connector Zone (Stog'er Tight to Argyle)
 - Argyle
 - The presence of a dock facility opens new opportunities for ore import from places like Goldboro and other Atlantic Canada mines.
 - The dock has great potential to ship additional aggregates worldwide. This potential is presently being further investigated.

Appendix D

Argyle Women's Employment Plan



Anaconda
Mining

**Women's Employment Plan
Point Rouse Project
Argyle Gold Mine**

TABLE OF CONTENTS

1	Introduction	3
1.1	Project Timeframes and Workforce Estimates	5
1.2	Employment Diversity Commitments and Practices	7
2	Recruitment and Employment.....	8
3	Communication	9
4	Monitoring.....	10
	Appendix 1: Employment Targets by Occupational Group	11



1 Introduction

Anaconda Mining is a growth-oriented, gold mining and exploration company operating a producing project called the Point Rouse Project with other exploration/development projects in the works.

As the only pure play gold producer in Atlantic Canada, Anaconda Mining is turning the rock we live on into a growing and profitable resource. With a young and motivated workforce, innovative technology and the support of local suppliers, Anaconda is investing in the people of Newfoundland & Labrador and giving back to the communities in which we operate.

The Point Rouse Project is located in the Baie Verte Mining District in Newfoundland, Canada. Since 2012, Anaconda has increased its gold production to approximately 16,000 ounces per year. In an effort to expand production, it is currently exploring other prospective gold trends, all within 8 kilometers of the Pine Cove Mill. The Company's plan is to discover and develop a larger resource portfolio and substantially increase annual production at the Pine Cove Mill.

The upcoming Argyle Gold Mine is located only 5 kilometers (km) away from the Pine Cove Mill and will be the second gold producing operation to follow its flagship Pine Cove Mine. Mining operations will leverage existing infrastructure to economically develop the resource at depth over the course of approximately 24 months, beginning in 2019.

Since 2008, Anaconda has been a major gold producer in the Ming's Bight Peninsula. Between Guy J. Bailey's, Shoreline Aggregates and Anaconda's workforce, the Point Rouse Project has been able to employ approximately 120 workers. The company has continuously looked to add employees from the local area throughout the company's growth and has ultimately served a significant role to the peninsula's economy.



This Women's Employment Plan (WEP) has been prepared for the Environmental Assessment for Argyle. This WEP describes the gender-equity goals and initiatives that Anaconda plans to implement by working collaboratively with our contractors and relevant community groups to help ensure a diverse and inclusive workforce during the various phases of the proposed work.

According to Natural Resources Canada, nationally women comprise of 17% of the mining workforce. At Anaconda Mining, 14% of the workforce is currently female with 33% female representation on the senior executive team. It is the goal of this Women's Employment Plan for women to comprise 20% of the workforce at Argyle which exceeds the national average by 3%.

At the executive level, CEO Dustin Angelo, COO Gordana Slepcev, and Vice Presidents Lynn Hammond, Alan Cramm, Paul McNeil and Rob Dufour routinely communicate their high regard for providing gender equality and a respectful environment for the company's workforce.

The company's commitment to providing a safe and healthy workplace has been rewarded by Newfoundland & Labrador Employers' Council with a 2017 Employer of Distinction Award. On-site, Operations Manager Tony Chislett and HR Coordinator Linus Doyle pay close attention to the daily relations between all employees and ensure the standards set at the executive level are achieved.

At Anaconda women are represented throughout the company including non-traditional occupations including engineering and technical services. It has been identified that skilled trades are a specific area where recruitment of women could be especially improved.



Anaconda is committed to gender equality within its workforce and will continue to provide equal opportunities, resources and rewards to both men and women within the company. Anaconda understands that a gender mixed workforce facilitates a healthy work environment and will encourage the participation of women in the workplace.

Anaconda is committed to establishing qualitative and quantitative goals for gender equity in order to improve employment outcomes for women in Newfoundland and Labrador. The Company has developed this Women's Employment Plan (WEP) to establish a proactive approach toward a workplace environment with policies and practices that help ensure a work environment free from harassment and discrimination.

1.1 Project Timeframes and Workforce Estimates

The project is scheduled to begin in 2019 and will continue through to 2021. At its peak during the construction phase in 2019, it is estimated that the Project will employ 61 people directly and indirectly.

The construction phase of the project will see the work completed that is required as preparation for mining operations. This includes the road upgrades, tree cutting, overburden stripping, and power distribution. The work will be completed in early 2019 so that mining operations can begin in late 2019. The workforce requirements and estimated number of workers required by NOC code for the Construction Phase are outlined in Table 1.

Table 1: Estimated Full-time Contractor-Hired (CH) or Direct Employee (DE) Hires, Construction Phase, by Occupation/NOC

Occupation	NOC	Duration of Work	Number of Employees	CH/DE
Project Management	0211	0.5 years	2	DE
Supervisors Skilled Trades	7301, 7302, 8221, 9211	0.5 years	12	CH & DE
Professionals	2113	0.5 years	1	DE
Semi-Professionals and Technicians	2113, 2212, 2143	0.5 years	4	DE
Skilled Trades	7242, 7311, 9411, 9231, 7521, 7372	0.5 years	36	CH & DE
Manual Workers	8614	0.5 years	4	CH & DE
Apprentices	2212	0.5 years	2	DE

The operations phase of the project includes drilling, blasting, mucking and hauling. Mining operations will be carried out over the course of 24 months in which two open pits will be developed to their economic potential. Anaconda will continue to employ Guy J. Baileys as a contractor, who will see a shift of both human resources and equipment from the construction phase into the operations phase of the project.

Table 2: Estimated Full-time (FT), Contractor-Hired (CH) or Direct Employee (DE) for the Operations Phase, 2018-2019 by Occupation//NOC

Occupation	NOC	Duration of Work	Number of Employees	CH/DE
Project Management	0211	2 years	2	DE
Supervisors Skilled Trades	7301, 7302, 8221, 9211	2 years	12	CH & DE
Professionals	2113	2 years	1	DE
Semi-Professionals and Technicians	2113, 2212, 2143	2 years	4	DE
Skilled Trades	7242, 7311, 9411, 9231, 7521, 7372	2 years	36	CH & DE
Manual Workers	8614	2 years	4	CH & DE
Apprentices	2212	2 years	2	DE

1.2 Employment Diversity Commitments and Practices

Anaconda has developed the following commitments to advance gender equity in employment and smooth the transition of women into leadership roles:

- Establish senior executive responsibilities for gender equality, develop capabilities and lines of accountability among senior management;
- Develop and communicate an executive-level vision statement to all staff and contractors, including commitments and goals;
- Communicate policies and practices related to recruitment, orientation, hiring, remuneration, retention, promotion, complaint resolution and termination;
- Establish targets and timeframes to increase the number of women in leadership roles and occupations where women are under-represented
- Provide training and other supports to develop an inclusive workplace culture; and
- Implement a monitoring system for gender equity as part of general HR systems and project planning/implementation.

2 Recruitment and Employment

Anaconda commits to the following measures to reduce the barriers to women's participation and improve their employment on this project.

- Anaconda will contact the Office to Advance Women Apprentices (OAWA) and the Women in Resource Development Corporation (WRDC) to seek recommendations regarding how the company can increase the number of female applicants for job competitions to support identified targets.
- Anaconda's internal employment equity process will include the following measures:
 - The line of accountability for Anaconda's Women's Employment Plan will begin on-site with our Operations Manager, Tony Chislett and HR Coordinator, Linus Doyle;
 - At the executive level, progress will be reported to Chief Operating Officer Gordana Slepcev and Vice President of Public Relations, Lynn Hammond.
 - Mandatory Site Orientation will include Respectful Workplace Policies for all new employees;
 - Existing employees will partake in Respectful Workplace training before the Project begins;
 - HR policies and practices will be reviewed for gender equity assurance;
- Anaconda will work with contractors to ensure compliance by requesting for women employment progress reports bi-annually. Progress reports will be reviewed by all parties accountable for compliance including those at the executive level.

3 Communication

To assist with maximizing opportunities for women, Anaconda is committed to outreach with a range of stakeholder organizations and institutions to improve opportunities for women through the following activities:

- Use appropriate language and imagery in all job advertisements and other communications to encourage women to apply for all job opportunities. A gender equity and diversity statement will be included in any such promotional materials related to the development of Argyle;
- Outreach to organizations supporting women in science, trades and technical occupations such as the Office to Advance Women Apprentices (OAWA), Women in Resource Development Corporation (WRDC), Women in Science and Engineering Newfoundland and Labrador (WISE), the Provincial Advisory Council on the Status of Women (PACSAW) the NL Department of Advanced Education, Skills and Labour and the Women's Policy Office;
- Work with education and training institutions and relevant industry and stakeholder organizations to provide awareness of job opportunities and the necessary skills required associated with Argyle;
- Participate in information sessions at the community level in collaboration with government and non-government stakeholders;
- Provide support for Women's Job Information workshops;
- Outreach to women business owners and business organizations such as the Newfoundland and Labrador Organization for Women Entrepreneurs (NLOWE) to share information about procurement processes;
- Include statements in tender documents to inform potential contractors of their obligation to comply with Anaconda's Women's Employment Plan through the employment and retention of women and in reporting the results of such efforts and outcomes with regards to their employment, particularly in non-traditional occupations;



- Incorporate gender-based analysis gathered from external stakeholders regarding women's employment and procurement into Anaconda's policy and workplace design decisions; and
- Develop and maintain a corporate culture and work environment within Anaconda that facilitates the achievement of the career goals of women and provides them with the training and support they need to assist them in meeting their goals and the goals of the company.

4 Monitoring

Anaconda will work closely with its main contractor(s) to ensure compliance with the Women's Employment Plan. Anaconda will hold meetings with contractors to clarify and address any issues with implementation of the Women's Employment Plan.

Anaconda will compile a bi-annual report that will include quantitative and qualitative descriptions of the following:

- The representation (number and percentages) of workers (by gender), location and NOC according to each occupational group;
- The duration of work (hours) broken down by gender and location;
- An update of qualitative supports/initiatives undertaken to encourage the employment of qualified women and to ensure a respectful workplace.

Anaconda Contacts:

Linus Doyle
Safety & Human Resources Coordinator
ldoyle@anacondamining.com

Lynn Hammond
Vice President Public Relations
lhammond@anacondamining.com

Appendix: Employment Targets by Occupational Group

Occupation (NOC)	FT/PT/ Seasonal	# of Employees	Target Female (%)	Direct Hire (DH) or Contractor (CT)	Estimated Timeframe
Project Management (0211)	FT	2	50%	DH	2.5 years
Administration (1111, 1432, 1414, 1221)	FT	4	75%	DH	2.5 years
Supervisors of Skilled Trades (8221, 9211, 7301, 7302)	FT	12	10%	DH & CT	2.5 years
Semi-Professionals, Technicians (2113, 2212, 2143)	FT	4	25%	DH & CT	2.5 years
Skilled Trades (7242, 7311, 9411, 9231, 7372, 7511, 7521)	FT	36	15%	DH & CT	2.5 years
Manual Workers/Labourers (8614)	FT & PT	5	20%	DH & CT	2.5 years
Apprentices (2212)	PT	3	33%	DH	2.5 years

Appendix E

Emergency Response Plan – Point Rouse Project

EMERGENCY RESPONSE PLAN

Authority:	Operations Manager	Issue Date:	November 1, 2017
Custodian:	Safety Officer	Revision Date:	Oct. 24, 2017
Issuing Department:	Safety	Document No.:	1.1

EMERGENCY RESPONSE PLAN

FOR

ANACONDA MINING INC. – POINT ROUSSE PROJECT



EMERGENCY RESPONSE PLAN

Authority:	Operations Manager	Issue Date:	November 1, 2017
Custodian:	Safety Officer	Revision Date:	Oct. 25, 2017
Issuing Department:	Safety	Document No.:	1.1

1.0 Table of Contents

1.0	EMERGENCY PHONE NUMBERS	3
2.0	POINT ROUSSE PROJECT FACILITY COMMUNICATION	4
1.1	NAME AND CONTACT INFORMATION	5
1.2	OPERATIONS MANAGER	5
1.3	EMERGENCY RESPONSE COORDINATOR	5
1.4	EMERGENCY RESPONSE TEAMS	5
1.5	EVACUATION WARDENS (MILL CREW LEADERS)	5
1.6	FIRST AID RESPONDENTS	5
	MINING LEASE NUMBER	6
	PERMIT NUMBER	6
	OPERATION TYPE	6
	PROPERTY LOCATION - COORDINATES	6
	NUMBER OF EMPLOYEES ON SITE	6
3.0	HAZARDS ANALYSIS:	6
I.	FIRE/EXPLOSION	6
II.	PERSONAL INJURY	7
III.	ENVIRONMENTAL	7

EMERGENCY RESPONSE PLAN

Authority:	Operations Manager	Issue Date:	November 1, 2017
Custodian:	Safety Officer	Revision Date:	Oct. 25, 2017
Issuing Department:	Safety	Document No.:	1.1

2.0 Emergency Phone Numbers

<u>ORGANIZATION</u>	<u>CONTACT</u>
Baie Verte Peninsula Health Centre	1-709-532-5200
Baie Verte Ambulance	1-709-532-5200
Baie Verte Hospital	1-709-532-5200/4281
Baie Verte RCMP	1-709-532-4221
Baie Verte Fire Department	1-709-532-4400
Ming's Bight Fire Department	1-709-254-7777/7461
La Scie Ambulance	1-709-675-2300
La Scie Medical Clinic	1-709-675-2529
La Scie Fire Department	1-709-675-2429
Department of Transportation - Baie Verte	1-709-292-4444
Ambulance, Police, and Fire	
(St. John's, Gander, Grandfalls-Windsor, & Corner Brook)	911
Emergency Measures Organization	1-709-729-3703
Poison Information Centers	
Corner Brook	1-709-634-7121
Gander	1-709-256-5552
Grand falls-Windsor	1-709-292-2500
St. Anthony	1-709-457-334
St. John's	1-709-722-1110
Department of Environment and Labor	
Information and Concerns	1-800-563-5471
Industrial Accidents Reporting	1-800-563-5471
OHS Industrial Accidents (Direct)	1-709-729-4444
Anaconda Mining Inc.	
Tony Chislett – Operations Manager	1-709-532-6490/4159
Jordan Cramm – Mine Superintendent	1-709-297-0011
Linus Doyle – Safety / HR Coordinator / MFSO	1-709-532-8598/4197
Tony Decker – Environmental Coordinator	1-709-532- 7748
Kevin Rice – Mill Superintendent	1-709-297-1105
Chris Budgett – Process Coordinator	1-709-673-7504
Anaconda Mining – Site Office	1-709-800-7332
Guy J Bailey Ltd. – Main office	1-709-532-4642/8216
Scott Bailey – Manager	1-709-532-7250
Peter Goudie – Site Supervisor	1-709-532-7295
Hillary Burt – Safety Coordinator/MFSO	1-709-532-4642
Shoreline Aggregates	
Shannon Lewis – Marine Facility Supervisor	1-709-532-7925
NFLD Hard-Rok	
Gerald Bursey – OnSite Manager	1-709-660-0516

EMERGENCY RESPONSE PLAN

Authority:	Operations Manager	Issue Date:	November 1, 2017
Custodian:	Safety Officer	Revision Date:	Oct. 25, 2017
Issuing Department:	Safety	Document No.:	1.1

3.0 POINT ROUSSE PROJECT FACILITY COMUNICATION

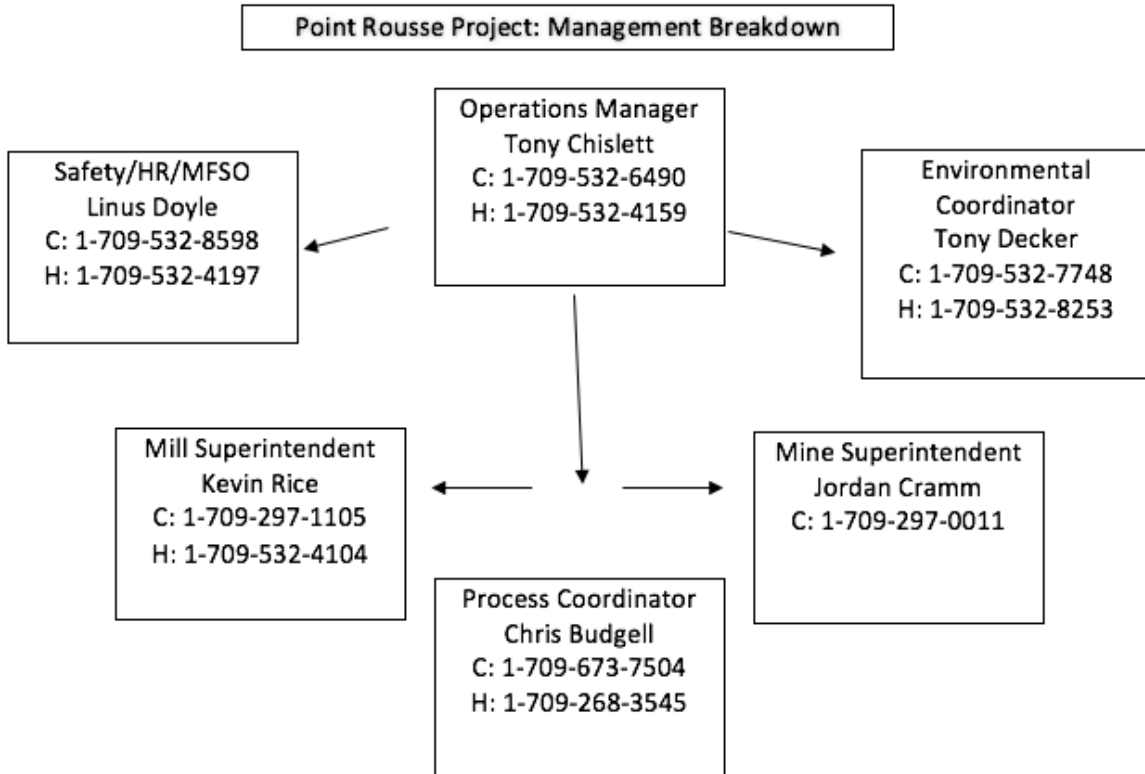

EMERGENCY RESPONSE PLAN

Authority:	Operations Manager	Issue Date:	November 1, 2017
Custodian:	Safety Officer	Revision Date:	Oct. 25, 2017
Issuing Department:	Safety	Document No.:	1.1

4.0 Mine Information

4.1 Name and Contact information

Point Rousse Project Gold Mine, operated by Anaconda Mining Inc
Baie Verte, White Bay
NL, A0K 1B0
1-709-800-7332 (mine site office)

4.2 Operations Manager

Tony Chislett

4.3 Emergency Response Coordinator

Linus Doyle

4.4 Emergency Response Teams

Primary team is the onsite mill crew, and secondary crew will be the onsite crusher crew or off-shift which will be called if needed. Off-site mill crews will be called in if needed.

4.5 Evacuation Wardens (Mill Crew Leaders)

Jonathan Pinksen

Darrin Regular

Paul Hurley

Todd Barrett

4.6 First Aid Respondents

Those holding First Aid Certificates. There are personnel at site trained in standard/emergency first aid; these people will be our emergency first respondents in the event of someone needing first aid on site.

EMERGENCY RESPONSE PLAN

Authority:	Operations Manager	Issue Date:	November 1, 2017
Custodian:	Safety Officer	Revision Date:	Oct. 25, 2017
Issuing Department:	Safety	Document No.:	1.1

4.7 Mining Lease Number

149(2663) and 189(11299M)

4.8 Permit Number

AA08-035500

4.9 Operation Type

Open Pit Gold Mine

4.10 Property Location – Coordinates

5534500N, 562500E

4.11 Number of Employees on site

43 Anaconda Mining Inc. staff members

20-24 equipment operators/employees employed through Guy J. Bailey Ltd. (Contractor)

1-4 driller/blasters employed through Nfld. Hard –Roc Inc. (Contractor)

2 Janitorial (Contractor)

20 Shoreline Aggregates Employees

5.0 Hazards Analysis:

I. Fire/Explosion

Furnace malfunction, welding equipment failure (oxygen/acetylene tanks), fire in fuel or propane tanks outside mill and trailer, electrical fire in mill or trailer.

EMERGENCY RESPONSE PLAN

Authority:	Operations Manager	Issue Date:	November 1, 2017
Custodian:	Safety Officer	Revision Date:	Oct. 25, 2017
Issuing Department:	Safety	Document No.:	1.1

II. Personal Injury

Exposure to hydrogen cyanide or ammonia gases, exposure to solid state chemicals, exposure to cyanide solution, slip and fall, equipment accidents, personal injury due to contact with molten material when burning gold out of concentrate, rock slide/pit wall collapse.

III. Environmental

Breach of dam/dam failure within the TMF, breach of various holding tanks within mill, tailings line breach, transferring fuel, equipment breakdown.

IV. Climate

Blizzard closing access road to site, lightning strike, power outage, road washout.

V. Equipment Failure

Mechanical failure causing accident/personal injury, fire and other emergencies associated with equipment.

VI. Suspected Hydrocyanic (HCN) Gas Release. (Worst Case Scenario)

On a regular work day, there would be approximately 7 employees on the mill floor. On a regular night shift, there would be 5 employees on the mill floor. Based on this information a worst-case emergency scenario would be based on 7 people.

EMERGENCY RESPONSE PLAN

Authority:	Operations Manager	Issue Date:	November 1, 2017
Custodian:	Safety Officer	Revision Date:	Oct. 25, 2017
Issuing Department:	Safety	Document No.:	1.1

6.0 Emergency Situation Responses

VII. Fire/Explosion

In case of a fire in the mill building, all personnel are to be evacuated. Everyone is to assemble at the emergency response unit (ERU) located in parking lot. Then once all personnel are accounted for and the Ming's Bight Fire Department has been contacted, and the risk of explosion has been ruled out, the emergency response team will man the firefighting equipment which is located on site.

(Three #2, Fire Hydrants has been installed on site. One next to Guy J Bailey's garage, one on end of the cold storage warehouse building, directly across from crusher ore storage building, and one located at the end of the maintenance building directly across from mill entrance steps. Please note that the Primary Emergency Response for Fire is the Ming's Bight Fire Department and Baie Verte is the Secondary Emergency Response provider.

In the case of an imminent explosion then personnel will be evacuated to a safe distance at the far Northeast corner of the site parking lot until local fire departments arrive to deal with the situation. In case of an injury caused by a fire or explosion there are a number of first aid kits located in the mill building and various locations around the site, there are also persons trained in first aid on staff, and for serious injury the injured person(s) will be taken to the ERU and given necessary first aid until an ambulance arrives on site to take over the situation.

VIII. Personal Injury

Personal injury encompasses a very wide spectrum of situations, and can range from inconsequential to very serious. Therefore, the response to a personal injury on site would be situation dependent.

For minor injuries, the situation should be assessed by the first person on scene, and someone with first aid training should be contacted. The equipment in the first aid centers would be sufficient in this sort of situation, however if this equipment is insufficient then the Baie Verte ambulance or Ming's Bight Fire Department should be contacted for further assistance.

For a more serious injury then the first respondent should contact the emergency response coordinator, followed by the Baie Verte hospital and an ambulance if required. While waiting for the ambulance to arrive the injured person(s) should

EMERGENCY RESPONSE PLAN

Authority:	Operations Manager	Issue Date:	November 1, 2017
Custodian:	Safety Officer	Revision Date:	Oct. 25, 2017
Issuing Department:	Safety	Document No.:	1.1

be moved to the emergency response unit and given appropriate first aid until assistance arrives.

There is also a set of special cases where personnel may become exposed to Cyanide; there are specific measures to be taken in that event.

For inhalation of Cyanide, the person(s) should be removed from the area immediately, away from the exposure, kept warm and at rest. Then obtain a cyanide antidote kit and administer oxygen to a conscious or unconscious victim, do not use mouth to mouth resuscitation.

For skin contact with Cyanide, remove all contaminated clothing immediately, and then wash with plenty of water, using one of the two chemical spill safety showers located in the mill near the furnace. Then treat the affected person(s) as for inhalation.

For ingestion of cyanide the treatment is very similar, do not give the affected person(s) anything by mouth, contact outside medical help and treat as for inhalation, until professional medical help arrives. In case of a non-breathing victim immediately remove them from the exposure area, obtain a cyanide antidote kit and administer oxygen. Do not use mouth to mouth resuscitation.

IX. Environmental

As stated in the contingency plan Anaconda Mining's (AMI's) policy is to implement preventative measures as its first line of defense against the possibility of accidents and/or unplanned situations.

The major concerns regarding the use of hazardous substances is their uncontrolled release to the environment through spillage and subsequent adverse effects on terrestrial, aquatic and marine habitat and species, soil, groundwater quality, and human health and safety. The Point Rouse mine/mill will use the following hazardous materials: gasoline, diesel, propane, Borax Decahydrate, Diatomaceous Earth, Flourspar, HS-325 Silica Flour, Lead Acetate, Magnafloc, Manganese Dioxide, Caustic Soda (Anhydrous), Hydrated Lime (Calcium Hydroxide), Sodium Metabisulphite, Lead Nitrate, Sodium Nitrate, Sodium Carbonate (Soda ash), Sodium Cyanide Bricks, Xanthates (KAX 51), and Copper Sulphate (Solid).

X. Climate

In the event that personnel are trapped on site due to weather conditions, equipment on site could be used to clear the road leading out to Ming's Bight

EMERGENCY RESPONSE PLAN

Authority:	Operations Manager	Issue Date:	November 1, 2017
Custodian:	Safety Officer	Revision Date:	Oct. 25, 2017
Issuing Department:	Safety	Document No.:	1.1

road, also a snow plow or grader stationed at Ming's Bight can be called to allow personnel to leave the mine site, or if conditions are sufficiently bad then personnel to stay on site until the weather conditions improve.

In the event of a Medical Emergency the following procedure shall apply:

1. Crew Leader is to contact crusher loader operator to STOP work and start the process of plowing Pine Cove road on the way out.
2. Crew Leader is to call Grader Operator (709-254-7471) to plow Pine Cove road coming into site. Grader and Loader operators MUST maintain radio communication.
3. Crew Leader to telephone Baie Verte Hospital (709-532-5200 or 911)
4. Baie Verte Hospital will coordinate with Department of Transportation (709-292-4444) to open highway.
5. Ambulance proceeds to site there is also the matter of a road wash out coupled with a personal injury or other situation on site; in that case, there is again equipment on site which can be used to remedy the situation in an emergency. Call the ambulance and meet it at the wash out site.

In the event of a power outage and there is an emergency. An emergency telephone is installed in the upstairs hallway of the mill (709-532-6370). If there is an issue with the telephone system this telephone can be used to make outside calls.

XI. [Equipment Failure/Accident](#)

In the event of an equipment failure related accident such as a truck collision or over turning etc.... First the individual who discovers the situation should contact the emergency response coordinator, also there are fire extinguishers in all site vehicles as well as first aid kits to either extinguish a small fire or treat minor injuries. There are also at least two people per team with first aid training who could be called upon to administer first aid to any injuries that may occur. If the situation is more serious than the first respondent should alert the emergency response coordinator, then immediately contact the Baie Verte ambulance, hospital, or fire department and administer appropriate first aid until professional help arrives.

EMERGENCY RESPONSE PLAN

Authority:	Operations Manager	Issue Date:	November 1, 2017
Custodian:	Safety Officer	Revision Date:	Oct. 25, 2017
Issuing Department:	Safety	Document No.:	1.1

XII. Suspected Hydrocyanic (HCN) Gas Release

HCN sensors will set off an initial **Amber Warning Light at 2.5 ppm and 4.7ppm for mill evacuation.** Upon hearing the mill evacuation alarm all personnel will evacuate and gather in the emergency response coordination center. Once this is done the emergency response coordinator will perform a count to make sure all personnel have evacuated the mill building. If this count reveals that not all personnel have evacuated, then the emergency response teams will be mobilized and the general manager will be contacted immediately. The emergency response teams consist of 2 persons each, 1 primary team and a secondary back –up team, who are properly trained and are wearing the proper PPE to enter the mill to retrieve anyone still inside. Once the proper checks and tests on the PPE equipment have been completed and the emergency response coordinator gives the okay then the emergency response team can enter the mill building and begin the evacuation of anyone trapped inside. Once injured personnel have been located and removed from danger then the focus turns to the application of relevant first aid, **the proper practices for cyanide poisoning first aid have been outlined above under personal injury.** The response would be quite similar if all personnel were accounted for, the emergency response teams would don their PPE, performing all the relevant checks, upon the approval of the emergency response coordinator they would enter the mill to attempt to remedy the situation. It is also at the discretion of the emergency response coordinator whether to call in outside assistance to aid the emergency response teams. When entering the mill building under such conditions the optimum route will be established based on the situation at hand. Otherwise the default emergency route is to be used. The travel route as well as a time limit will be set and there will be someone outside the mill building monitoring the teams time under oxygen. When the proposed trip is completed the team will report back to the emergency response center, and a second team will be deployed if necessary. Upon the rescue of a victim again the first response for cyanide poisoning as well as first aid procedure will be implemented and continued until the appropriate professional help arrives (outlined above under personal injury). Once all personnel are accounted for and the emergency response teams have determined that the atmosphere inside the mill is once again within the safe breathing limits the team will report back to the emergency response center, and the mill ventilation will be allowed to run for at least 2 hours and the atmosphere inside will be checked by

EMERGENCY RESPONSE PLAN

Authority:	Operations Manager	Issue Date:	November 1, 2017
Custodian:	Safety Officer	Revision Date:	Oct. 25, 2017
Issuing Department:	Safety	Document No.:	1.1

qualified personnel, and no one is to re-enter the mill until approval is given by the emergency response coordinator.

7.0 Local Medical and Fire Response Contingencies

The Baie Verte Peninsula Health Center is in the town of Baie Verte, approximately 31 kilometers from the Anaconda Mine Site and can be reached at **709-532-5200**. Anaconda Mining Inc. has met with staff at the hospital and fire departments to determine the requirements in the event of an emergency at the Pine Cove mine site. In the event of a medical or fire emergency at the Pine Cove site the emergency room staff at the hospital and fire department will require the following information:

1. Location
2. Number of casualties
3. Name of Casualties (only on landline)
4. Type and Extent of injuries (i.e.: burn, chemical exposure, etc...)
5. Who has been notified
6. Is a physician or RN required on site
7. When the incident occurred
8. Is PPE required for the emergency room staff

7.1 Primary Fire Department

Located in the town of Ming's Bight at approximately 8 kilometers from Anaconda Mine Site. The **Ming's Bight Fire Department** can be reached at **709-254-7777** and will provide the following emergency services:

1. Fire Emergency Response
2. Routine and periodic training exercises
3. Run mock exercises and emergency simulations at site
4. Oversee maintenance on Anaconda Mine fire-fighting equipment

The **Baie Verte Fire Department** is in the town of Baie Verte at a distance approximately 31 kilometers from Anaconda Mine Site. They can be reached at **709-532-4400** and will provide the following emergency services:

EMERGENCY RESPONSE PLAN

Authority:	Operations Manager	Issue Date:	November 1, 2017
Custodian:	Safety Officer	Revision Date:	Oct. 25, 2017
Issuing Department:	Safety	Document No.:	1.1

1. Provide fire emergency response back- up support to Ming's Bight Fire Department if needed.
2. Participate in mock and emergency exercises at site
3. Refill SCBA oxygen cylinders as needed.

8.0 Emergency Response Equipment

- Scott artificial air breathing apparatus (2 for primary team, 2 for back up team and 1 spare)
- 1 Mobile fire pump (located under steps of mill stairwell)
- 4 Hand held portable flashlights
- 2 Utility knives
- 4 Sets of impermeable clothing
- 5 Pairs of heavy duty rubber gloves
- 1 Stretcher
- 1 Large first aid station
- 2 Multi gas detector
- Spill kits & additional spill equipment.
- 7 Medical Oxygen air breathing Apparatus
- 4 Cyanokits containing 5g powder for Solution for infusion (5 in Emergency Response Center and 2 in Mill)
- 2 encapsulated Chemical Suits
- Emergency Food rations
- Emergency blankets
- Emergency cots/beds

9.0 First Aid for Injuries on Site

When an accident or injuries is discovered on site the following procedure should be followed:

- The first person to discover the accident/injury should stay calm, and administer first aid to anyone needing assistance.
- Assess the potential for further injury from the site of the accident, and if further injury to the victim or respondent is possible then the injured person(s) should be moved away from the potential danger.

EMERGENCY RESPONSE PLAN

Authority:	Operations Manager	Issue Date:	November 1, 2017
Custodian:	Safety Officer	Revision Date:	Oct. 25, 2017
Issuing Department:	Safety	Document No.:	1.1

- Contact the emergency response coordinator or first respondent to request further assistance in treating the injured person(s), and make sure that outside medical help has been contacted if necessary.
- Keep the injured person(s) comfortable and make sure the area is secured until medical help arrives.
- Participate in the reporting of the incident.

10. Site Directions

The Point Rousse Project mine site is located approximately 5 km northeast of the town of Baie Verte.

To reach the work site from the town of Baie Verte you must take highway 410 towards the Trans-Canada Highway, take a left turn at the junction of highway 410 and highway 414 (La Scie Road), travel along this highway until reaching another junction (approximately 20 kilometers), and take a left turn at the junction of Ming's Bight road (highway 418) and La Scie Road. Travelling north on Ming's Bight road it is approximately 6 kilometers to the intersection of Pine Cove road and the Ming's Bight highway. Take the left onto the dirt road (Pine Cove Road) and the Point Rousse Project mine site is approximately 6 kilometers along this road, making sure to stay on the main road, by keeping left at all junctions.

To reach the site from La Scie, take La Scie road west towards the town of Baie Verte, and take a right at the junction of Ming's Bight road and La Scie road, from here it is the same as from Baie Verte. To reach the mine site from Ming's Bight, drive south out of Ming's Bight approximately 3 kilometers, turn right onto Pine Cove road and follow it to the mine site, again staying left on at all junctions. Taking into consideration Pine Cove road conditions and distances from the towns of Ming's Bight and Baie Verte. It is anticipated that it would take approximately 20 minutes for the Ming's Bight Fire Department to arrive. It would take approximately 40 minutes for the Baie Verte Ambulance and Fire Department to arrive at the Anaconda Mine site.

Appendix F

Contingency Plan – Point Rouse Project

CONTINGENCY PLAN
FOR
ANACONDA MINING INC. – POINT ROUSSE PROJECT



CONTINGENCY PLAN

Authority:	Operations Manager	Issue Date:	-
Custodian:	Environmental Coordinator	Revision Date:	Oct. 16, 2017
Issuing Department:	Environmental	Document No.:	1.1

Table of Contents

1.0 Fuel and Hazardous Material Spills on Land - 5 -

1.1 Environmental Concerns..... - 5 -

1.2 Environmental Protection Procedures..... - 5 -

2.0 Wildlife Encounters..... - 8 -

2.1 Environmental Concerns - 8 -

2.2 Environmental Protection Procedures..... - 8 -

 2.2.1 Prevention..... - 8 -

 2.2.2 Response Actions - 8 -

3.0 Discovery of Historic Resources - 10 -

3.1 Environmental Protection Procedures - 10 -

4.0 Forest Fires - 11 -

4.1 Environmental Concerns..... - 11 -

4.2 Environmental Protection Procedures..... - 11 -

5.0 Mine Safety and First Aid - 12 -

5.1 Environmental Protection Procedures..... - 12 -

6.0 Fire on Surface - 13 -

6.1 Environmental Protection Procedures..... - 13 -

7.0 Spill from the Tailings and Process Water Lines - 14 -

7.1 Environmental Concerns..... - 14 -

7.2 Environmental Protection Procedure - 14 -

8.0 Mill Reactive Product Spill - 16 -

8.1 Environmental Concerns..... - 16 -

8.2 Environmental Protection Procedure - 16 -

9.0 Environmental Effects Monitoring – Pine Cove..... - 18 -

9.1 Water Quality Monitoring Program..... - 18 -

 9.1.1 Effluent Monitoring..... - 18 -

 9.1.2 Surface and Ground Water Monitoring - 20 -

9.2 Analysis and QA/QC..... - 21 -

10.0 Contingency Plan Location - 21 -

CONTINGENCY PLAN

Authority:	Operations Manager	Issue Date:	-
Custodian:	Environmental Coordinator	Revision Date:	Oct. 16, 2017
Issuing Department:	Environmental	Document No.:	1.1

EMERGENCY PHONE NUMBERS

<u>Organization</u>	<u>Phone</u>
Baie Verte Peninsula Health Centre	1-709-532-5200
Baie Verte Ambulance	1-709-532-5200
Baie Verte Hospital	1-709-532-5200/4281
Baie Verte RCMP	1-709-532-4221
Baie Verte Fire Department	1-709-532-4400
Ming's Bight Fire Department	1-709-254-7777/7461 /6516
La Scie Ambulance	1-709-675-2300
La Scie Medical Clinic	1-709-675-2529
La Scie Fire Department	1-709-675-2429
Department of Transportation - Baie Verte	1-709-292-4444
Ambulance, Police, and Fire	
(St. John's, Gander, Grandfalls-Windsor, & Corner Brook)	911
Emergency Measures Organization	1-709-729-3703
Poison Information Centers	
Corner Brook	1-709-634-7121
Gander	1-709-256-5552
Grand falls-Windsor	1-709-292-2500
St. Anthony	1-709-457-334
St. John's	1-709-722-1110
Department of Environment and Labor	
Information and Concerns	1-800-563-5471
Industrial Accidents Reporting	1-800-563-5471
OHS Industrial Accidents (Direct)	1-709-729-4444
Anaconda Mining -Main Office	
Tony Chislette – General Manager	1-709-532-6490/4159
Jordan Cramm – Mine Superintendent	1-709-297-0011
Linus Doyle – Safety / HR Coordinator / MFSO	1-709-532-8598/4197
Tony Decker – Environmental Coordinator	1-709-532- 7748
Kevin Rice – Mill Superintendent	1-709-297-1105/ 1-709-532-4104
Chris Budgell – Process Coordinator	1-709-800-7332/2114
Anaconda Mining – Site Office	1-709-800-7332
Guy J Bailey Ltd. – Main office	1-709-532-4642/ 8216
Scott Bailey – Manager	1-709-532-7250
Peter Goudie – Site Supervisor	1-709-532-7295
Hillary Burt – Safety Coordinator/MFSO	1-709-532-4642
Shoreline Aggregates	
Shannon Lewis	1-709-532-7925

CONTINGENCY PLAN

Authority:	Operations Manager	Issue Date:	-
Custodian:	Environmental Coordinator	Revision Date:	Oct. 16, 2017
Issuing Department:	Environmental	Document No.:	1.1

POINT ROUSSE PROJECT FACILITY COMMUNICATIONS

The following flow chart outlines the on-scene-commander and designates in a case where the Project Manager is absent from the site:

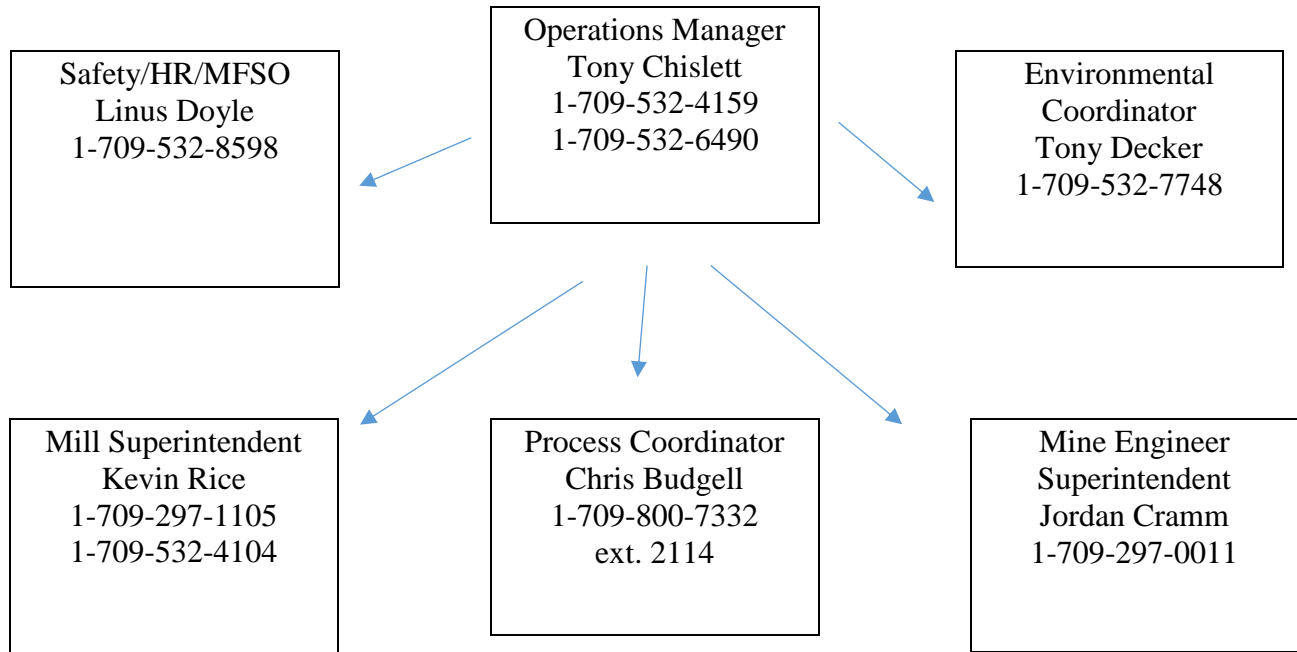

INTRODUCTION

Contingency, plans to deal with accidents. Response to unplanned situations have been developed, and will be modified as required throughout the project.

In reaching decisions on containment and clean-up procedures, the objectives of these contingency plans are to minimize the following:

- Danger to persons;
- Pollution to water courses;
- Area affected by the spill or fire;
- Degree of disturbance to the area and water courses during clean-up; and
- Degree of disturbance to wildlife.

Although the following contingency plans are put in place it is still Anaconda Mining Inc. (AMI) policy to implement preventative measures as its first line of defense against the possibility of accidents and/or unplanned situations.

CONTINGENCY PLAN

Authority:	Operations Manager	Issue Date:	-
Custodian:	Environmental Coordinator	Revision Date:	Oct. 16, 2017
Issuing Department:	Environmental	Document No.:	1.1

1.0 Fuel and Hazardous Material Spills on Land

All employees working in the mill operations have attended a cyanide safety course which entailed safe handling and emergency response techniques sponsored by DuPont Chemicals. Also, all mill operations personnel receive ongoing mill emergency response training on a monthly basis. This training covers all aspects of chemical safety and handling, Haz-Mat training, general firefighting skills and first aid training.

1.1 Environmental Concerns

The major concerns regarding the use of hazardous substances is their uncontrolled release to the environment through spillage and subsequent adverse effects on terrestrial, aquatic and marine habitat and species, soil, groundwater quality and human health and safety. The Pine Cove mine/mill will use the following hazardous materials: gasoline, diesel, sodium cyanide, zinc powder, sodium metabisulphite, lime, flotation reagents (sodium xanthate and MIBC) and copper sulphate.

Burnt or hydrated lime will be used for pH control in the leaching circuit to guarantee a pH of 10 or higher. Sodium cyanide will be used as a lixiviant to leach the gold from the solution. Detoxification of cyanide concentrate tailings will be completed with sodium meta bisulphite and compressed (diffused) air used as an oxidant with a copper sulfate catalyst. The reagent storage area will have an impermeable floor and raised lip to contain a potential spill and leakage. Fuel for equipment will be delivered with the use of mobile fuel equipment.

All buildings on site are self-contained (no drainage to the outside) and as a result there are no expected significant environmental concerns with regards to spillage in the mill or reagent storage buildings. The main concern would be the safety of the personnel.

When the final site layout and plans are completed, a list and map will depict all locations of fuel storage.

1.2 Environmental Protection Procedures

In case of a fuel or hazardous material spill, the following procedures will apply.

- a) The individual who discovers the leak or spill will make a reasonable and safe attempt to immediately stop the leakage and contain the flow. Spill kits are located at fuel storage tanks and at designated central storage location(s).

CONTINGENCY PLAN

Authority:	Operations Manager	Issue Date:	-
Custodian:	Environmental Coordinator	Revision Date:	Oct. 16, 2017
Issuing Department:	Environmental	Document No.:	1.1

- b) Spill location, type of fuel or hazardous material, volume and terrain condition at the spill will be determined and reported immediately to the Project Manager, who will report it immediately to Environment Canada (Item c) and other Government Departments.
- c) In the event of any spill on land regardless of size that may enter a waterbody frequented by fish must be reported immediately to the spill line (709) 772-2083 or (800) 563-9089 as required by the *Fisheries Act*. Required pertinent information includes:
 - i) name of reporter and phone number;
 - ii) time of spill or leak;
 - iii) time of detection of spill or leak;
 - iv) type of product spilled or leaked;
 - v) amount of product spilled or leaked;
 - vi) location of spill or leak;
 - vii) source of spill or leak;
 - viii) type of accident – collision, rupture, overflow, other;
 - ix) owner of product and phone number;
 - x) if the spill or leak is still occurring;
 - xi) if the spill or leaked product is contained, and if not, where it is flowing
 - xii) wind velocity and direction;
 - xiii) temperature;
 - xiv) proximity to water bodies, water intakes, and facilities; and
 - xv) snow cover and depth, terrain and soil conditions.
- d) The Project Manager will act as the “On-Scene-Commander” for the purposes of cleaning up a fuel or hazardous materials spill. The Project Manager is familiar with spill clean-up procedures and mobilization procedures of the clean-up equipment. The Project Manager has full authority to take necessary and appropriate action without unnecessary delay.
- e) In reaching decisions on containment and clean-up procedures, the following criteria will be applied:
 - i) minimize danger to persons;
 - ii) protect water supplies;
 - iii) minimize pollution of water courses;
 - iv) minimize area affected by spill; and
 - v) minimize the degree of disturbance to the area and water courses during clean-up.

CONTINGENCY PLAN

Authority:	Operations Manager	Issue Date:	-
Custodian:	Environmental Coordinator	Revision Date:	Oct. 16, 2017
Issuing Department:	Environmental	Document No.:	1.1

- f) The Project Manager will act in consultation with the regulating authorities to:
 - i) assess site conditions and environmental impacts of various cleanup procedures;
 - ii) assess potential for fuel recovery versus burning;
 - iii) deploy on-site staff to mobilize pumps and empty 215-L drums or other appropriate storage containers to the spill site;
 - iv) deploy on-site staff to build containment dykes and commence pumping contaminant into drums;
 - v) apply absorbent as necessary;
 - vi) dispose of all contaminated debris, cleaning materials and absorbent by burning, if appropriate, or by placing it in an approved land-fill site and;
 - vii) take all necessary precautions to ensure that the incident does not recur.

- g) The Project Manager will be responsible for the preparation of a written report which will be sent (as soon as possible and no later than 30 days after the spill) to Anaconda; and, from there to:

Newfoundland and Labrador Department of Government Services
 Government Service Center
 9 Queensway
 Grand Falls-Windsor, NL
 Telephone: (709) 292-4206

Graham Thomas
 Environmental Emergencies Coordinator
 Environment Canada
 6 Bruce Street Mount Pearl, NL A1N 4T3
 (709) 772-4285 (Business)
 (709) 687-5634 (Cell)

All employees working in the mill operations have attended a cyanide safety course which entailed safe handling and emergency response techniques sponsored by DuPont Chemicals. Also, all mill operations personnel receive ongoing mill emergency response training on a monthly basis. This training covers all aspects of chemical safety and handling, Haz-Mat training, general firefighting skills and first aid training.

CONTINGENCY PLAN

Authority:	Operations Manager	Issue Date:	-
Custodian:	Environmental Coordinator	Revision Date:	Oct. 16, 2017
Issuing Department:	Environmental	Document No.:	1.1

2.0 Wildlife Encounters

2.1 Environmental Concerns

Anaconda Mining Inc. realizes that we are located in a natural wildlife habitat and as such there is potential for wildlife encounters. The main concern here is the risk to animals and wildlife.

2.2 Environmental Protection Procedures

2.2.1 Prevention

As a protection measure, hunting, trapping, or fishing by project personnel is not permitted at the site.

The Project Manager is responsible to see that the following procedures relating to storage and waste disposal are implemented:

- a) Site and working areas will be kept clean of food scraps and garbage.
- b) Waste will be collected for the disposal in bear-resistant containers. Waste will be transferred to the local landfill located in Ming's Bight on a weekly basis.

2.2.2 Response Actions

All project personnel will abide by the following rules in cases of wildlife encounters:

- a) No attempt will be made by any person at the project site to chase, catch, divert, follow or otherwise harass wildlife by vehicle or on foot.
- b) Equipment and vehicles will yield the right-of-way to wildlife.
- c) No personal pets, domestic or wild, will be allowed on the site. However, if a dog is required for deterrence purposes, approval will be obtained.
- d) All personnel should be aware of the potential for encounters with black bears and instructed to immediately report all sightings to the Project Manager. At the Project Managers discretion, the supervisor will notify the Forest Resources District office in Springdale ((709) 673-3821/3823) and the Wildlife Division.

CONTINGENCY PLAN

Authority:	Operations Manager	Issue Date:	-
Custodian:	Environmental Coordinator	Revision Date:	Oct. 16, 2017
Issuing Department:	Environmental	Document No.:	1.1

- e) When “nuisance” animals (e.g., black bear or beaver) are identified in the project area, the Project Manager will be responsible for all subsequent actions. Responsive actions will be determined by the Project Manager, who will consult with the Forestry Services District office in Springdale and with the Inland Fish and Wildlife Division prior to any active intervention (except in emergency). All actions must comply with Inland Fish and Wildlife Division regulations and permits.
- f) The Project Manager must authorize the use of deterrent measures that include crackers and rubber bullets.
- g) Under the provincial wildlife regulations, the displacement and release of any wild animal is the jurisdiction of the Forestry Branch and the Wildlife Division and is to be undertaken only under Wildlife supervision.
- h) A permit will be required to destroy nuisance animals; an approved firearm will be kept at site for that purpose. The Project Manager (or a representative of the Inland Fish and Wildlife Division) will determine if an animal is to be destroyed and will designate who will destroy the animal. The only firearms(s) allowed on- site are those under the control of the Project Manager (or his/her designate). Anytime an animal is destroyed, the Inland Fish and Wildlife Division will be notified.
- i) A draft report of the displacement or killing of a bear will be prepared by the Project Manager and provided to personnel involved. A detailed written report will be submitted to Anaconda, and the Inland Fish and Wildlife Division within 48 hours of killing a bear.

CONTINGENCY PLAN

Authority:	Operations Manager	Issue Date:	-
Custodian:	Environmental Coordinator	Revision Date:	Oct. 16, 2017
Issuing Department:	Environmental	Document No.:	1.1

3.0 Discovery of Historic Resources

3.1 Environmental Protection Procedures

In case of the discovery of a historic or prehistoric artefact or archaeologist site, the following procedures will apply:

- a) Under the *Historic Resources Act* all archaeological sites and artefacts are considered the property of the Crown, and must not be disturbed. Aboriginal peoples and other residents of the Pine Cove area are also concerned about the preservation and protection of archaeological and other cultural resources. Anaconda or the Contractor will take all reasonable precautions to prevent employees or other persons from removing or damaging any such articles or sites and may be held liable for prosecution under Sections 35.1 and 35.2 of the *Historic Resources Act* for all contraventions. Personnel working in the vicinity will be advised of the find. The site area will be flagged for protection and avoidance.
- b) All work will cease in the immediate area of the discovery until Anaconda advises the authorities of the discovery and, in consultation with the Provincial Archaeologists, authorizes a resumption of the work. If required, a full assessment will be conducted of the site and immediate area.
- c) Archaeological materials encountered will be reported initially to the Project Manager and immediately thereafter to Ms. Martha Drake, Resource Archaeologist, Culture and Heritage Division, at (709) 729-2462, fax (709) 729-0870, with the following information:
 - i) nature of activity
 - ii) nature of the material discovered; and
 - iii) precise location of the find.

Following and assessment of the significance and mitigation needs, a report will be made to Anaconda and the Culture and Heritage Division. Any proposed mitigation will first be approved by the Culture and Heritage Division.

CONTINGENCY PLAN

Authority:	Operations Manager	Issue Date:	-
Custodian:	Environmental Coordinator	Revision Date:	Oct. 16, 2017
Issuing Department:	Environmental	Document No.:	1.1

4.0 Forest Fires

4.1 Environmental Concerns

As with any activity there is a possibility of a forest fire occurring at site. This can destroy forest growth and wildlife.

4.2 Environmental Protection Procedures

The fire prevention and fire-fighting procedures described below will be followed. Anaconda or the Contractor will take all precautions necessary to prevent fire hazards when working at the site. These include but are not limited to:

- a) Disposal of all flammable waste on a regular basis.
- b) Anaconda or the Contractor making available, in proper operating condition, sufficient firefighting equipment to suit its labour force and fire hazards. The equipment will be maintained to the manufacturer's standards and will be in accordance with the Operating Permit issued by the DNR during the "Fire Season"
- c) Anaconda or the Contractor ensuring that its personnel are trained in the use of such equipment.
- d) In case of a forest fire, Anaconda or the Contractor will take immediate steps to contain or extinguish fire.
- e) Anaconda will appoint a supervisory staff member to undertake initial fire attack procedures and to act as a liaison between company personnel and Department of Natural Resources firefighters should the situation require additional resources.

CONTINGENCY PLAN

Authority:	Operations Manager	Issue Date:	-
Custodian:	Environmental Coordinator	Revision Date:	Oct. 16, 2017
Issuing Department:	Environmental	Document No.:	1.1

- f) All wildfires should be reported immediately to the Project Manager, the Springdale Forest Ecosystem District Office (709) 673-3821 and the Regional Fire Duty Officer at Corner Brook (709) 637-2408. The following information will be provided:
 - i) Name of the person reporting the fire incident;
 - ii) Telephone number of the person reporting the fire incident.
 - iii) Location of the fire, referencing the name of the local area and the name of the nearest community.
 - iv) Time of the fire detection.
 - v) Estimate of fire size.
 - vi) Type of vegetation burning.
 - vii) Wind direction and estimate of wind speed.
 - viii) Number of persons fighting the fire.
 - ix) Name of person supervising the firefighting activities and how that person may be contacted.
- g) The RCMP will also be notified immediately at (709) 532-4221.

5.0 Mine Safety and First Aid

5.1 Environmental Protection Procedures

- a) A room in the office complex will be designated as a marshalling point for all employees in case of an emergency. Further, a designated room will be maintained as an Emergency Control Center to serve as a base of operations during a mine emergency. The room will contain the required communications equipment, written emergency procedures and a set of mine plans.
- b) A first aid station will be provided in the office/dry complex. There will be personnel with first aid training on-site at all times during operation. An emergency vehicle will be available at all times to take emergency cases to local hospitals if necessary.
- c) An emergency vehicle will be on-site. The vehicle will include equipment for environmental emergencies (i.e., special clothing and absorbent material).

CONTINGENCY PLAN

Authority:	Operations Manager	Issue Date:	-
Custodian:	Environmental Coordinator	Revision Date:	Oct. 16, 2017
Issuing Department:	Environmental	Document No.:	1.1

6.0 Fire on Surface

6.1 Environmental Protection Procedures

The fire prevention and fire-fighting procedures described below will be followed. Anaconda or the Contractor will take all precautions necessary to prevent fire hazards when working at the site. These include but are not limited to:

- i) Disposal of all flammable waste on a regular basis.
- ii) Anaconda or the Contractor making available, in proper operating condition, sufficient firefighting equipment to suit its labour force and fire hazards. The equipment will be maintained to the manufacturer's standards and will be in accordance with the Operating Permit issued by the DNR during the "Fire Season".
- iii) Anaconda or the Contractor ensuring that its personnel are trained in the use of such equipment.
- iv) In case of a fire, Anaconda or the Contractor will take immediate steps to contain or extinguish fire.
- v) Anaconda will appoint a supervisory staff member to undertake initial fire attack procedures and to act as a liaison between company personnel and a local fire department(s). If needed the Baie Verte Fire Department will be called to deal with any fires that beyond the capabilities of the firefighting abilities at the site.
- vi) All fires should be reported immediately to the Project Manager. The following information will be provided:
 - i) Name of the person reporting the fire incident.
 - ii) Location of the fire.
 - iii) Time of the fire detection.
 - iv) Estimate of fire size.
 - v) Wind direction and estimate of wind speed.
 - vi) Number of persons fighting the fire.
- vii) The RCMP will also be notified immediately at (709) 532-4221.

CONTINGENCY PLAN

Authority:	Operations Manager	Issue Date:	-
Custodian:	Environmental Coordinator	Revision Date:	Oct. 16, 2017
Issuing Department:	Environmental	Document No.:	1.1

7.0 Spill from the Tailings and Process Water Lines

7.1 Environmental Concerns

Release of fluids from the tailings and process water lines may damage flora, fauna, surface water, groundwater and aquatic organisms.

7.2 Environmental Protection Procedure

Any accidental spills of fluids from tailings and process water lines may occur within the tailings and process water lines.

The lines have been installed so that if they do leak the fluids will drain towards the tailings containment area.

In case of a spill, the following procedures will apply.

- a) The individual who discovers the leak or spill will make a reasonable and safe attempt to immediately stop the leakage and contain the flow. Spill kits are located at designated central storage location(s).
- b) Spill location, type of material, volume and terrain condition at the spill will be determined and reported immediately to the Project Manager, who will report it immediately to Environment Canada (Item c).

In the event of any spill on land regardless of size that may enter a waterbody frequented by fish must be reported immediately to Newfoundland and Labrador Regional Office Canadian Coast Guard Fisheries and Oceans Canada, the spill line (709) 772-2083 or (800) 563-9089 as required by the *Fisheries Act*. Required pertinent information includes:

- i) name of reporter and phone number;
- ii) time of spill or leak;
- iii) time of detection of spill or leak;
- iv) type of product spilled or leaked;
- v) amount of product spilled or leaked;
- vi) location of spill or leak;
- vii) source of spill or leak;
- viii) type of accident – collision, rupture, overflow, other;
- ix) owner of product and phone number;
- x) if the spill or leak is still occurring;
- xi) if contained, and if not, where it is flowing;
- xii) wind velocity and direction;
- xiii) temperature;
- xiv) proximity to water bodies, water intakes, and facilities; and
- xv) snow cover and depth, terrain and soil conditions;

CONTINGENCY PLAN

Authority:	Operations Manager	Issue Date:	-
Custodian:	Environmental Coordinator	Revision Date:	Oct. 16, 2017
Issuing Department:	Environmental	Document No.:	1.1

- c) The Project Manager will act as the “On-Scene-Commander” for the purposes of cleaning up a spill. The Project Manager is familiar with spill clean-up procedures and mobilization procedures of the clean-up equipment. The Project Manager has full authority to take necessary and appropriate action without unnecessary delay.
- d) In reaching decisions on containment and clean-up procedures, the following criteria will be applied:
 - i) minimize danger to persons;
 - ii) protect water supplies;
 - iii) minimize pollution of water courses;
 - iv) minimize area affected by spill; and
 - v) minimize the degree of disturbance to the area and water courses during clean-up.
- e) The Project Manager will act in consultation with the regulating authorities to:
 - i) assess site conditions and environmental impacts of various cleanup procedures;
 - ii) assess potential for fuel recovery versus burning;
 - iii) deploy on-site staff to mobilize pumps and empty 215-L drums or other appropriate storage containers to the spill site;
 - iv) deploy on-site staff to build containment dykes and commence pumping contaminant into drums;
 - v) apply absorbent as necessary;
 - vi) dispose of all contaminated debris, cleaning materials and absorbent by burning, if appropriate, or by placing it in an approved land-fill site; and
 - vii) take all necessary precautions to ensure that the incident does not recur.
- f) The Project Manager will be responsible for the preparation of a written report which will be sent (as soon as possible and no later than 30 days after the spill) to Anaconda; and, from there to:

Newfoundland and Labrador Department of Government Services
 Government Service Center
 9 Queensway
 Grand Falls-Windsor, NL
 B: (709) 292-4206
 Fax: (709) 292-4528

Graham Thomas
 Environmental Emergencies Coordinator
 Environment Canada
 6 Bruce Street
 Mount Pearl, NL A1N 4T3
 B: (709) 772-4285 (Business) / C: (709)687-5634 (Cell)

CONTINGENCY PLAN

Authority:	Operations Manager	Issue Date:	-
Custodian:	Environmental Coordinator	Revision Date:	Oct. 16, 2017
Issuing Department:	Environmental	Document No.:	1.1

8.0 Mill Reactive Product Spill

8.1 Environmental Concerns

Release of fluids from a spill in the mill may damage flora, fauna, surface water, groundwater and aquatic organisms.

8.2 Environmental Protection Procedure

If a spill occurs in the mill it will be contained within the mill in the self-contained drainage basins. The floor of the mill has been constructed so that all fluids spilled in the mill will drain to the drainage basins. The spilled fluids can then be pumped back into the circuit. Due to the fact that the mill is an enclosed unit it is unlikely that a spill will find a way to the environment.

In case of a spill, the following procedures will apply.

- a) The individual who discovers the leak or spill will make a reasonable and safe attempt to immediately stop the leakage and contain the flow. Spill kits are located at designated central storage location(s).
- b) Spill location, type of material, volume and terrain condition at the spill will be determined and reported immediately to the Project Manager, who will report it immediately to Environment Canada (Item c).
- c) In the event of any spill on land regardless of size that may enter a waterbody frequented by fish must be reported immediately to the Newfoundland and Labrador Regional Office Canadian Coast Guard Fisheries and Oceans Canada, spill line (709) 772-2083 or (800) 563-9089 as required by the *Fisheries Act*. Required pertinent information includes:
 - i) Name of reporter and number;
 - ii) time of spill or leak;
 - iii) time of detection of spill or leak;
 - iv) type of product spilled or leaked;
 - v) amount of product spilled or leaked;
 - vi) location of spill or leak;
 - vii) source of spill or leak;
 - viii) type of accident – collision, rupture, overflow, other;
 - ix) owner of product and phone number;
 - x) if the spill or leak is still occurring;
 - xi) if the spill or leaked product is contained, and if not, where it is flowing;
 - xii) wind velocity and direction;
 - xiii) temperature;
 - xiv) proximity to water bodies, water intakes, and facilities; and
 - xv) snow cover and depth, terrain and soil conditions.

CONTINGENCY PLAN

Authority:	Operations Manager	Issue Date:	-
Custodian:	Environmental Coordinator	Revision Date:	Oct. 16, 2017
Issuing Department:	Environmental	Document No.:	1.1

- d) The Project Manager will act as the “On-Scene-Commander” for the purposes of cleaning up a spill. The Project Manager is familiar with spill clean-up procedures and mobilization procedures of the clean-up equipment. The Project Manager has full authority to take necessary and appropriate action without unnecessary delay.
- e) In reaching decisions on containment and clean-up procedures, the following criteria will be applied:
 - i) minimize danger to persons;
 - ii) protect water supplies;
 - iii) minimize pollution of water courses;
 - iv) minimize area affected by spill; and
 - v) minimize the degree of disturbance to the area and water courses during clean-up.
- f) The Project Manager will act in consultation with the regulating authorities to:
 - i) assess site conditions and environmental impacts of various cleanup procedures;
 - ii) assess potential for fuel recovery versus burning;
 - iii) deploy on-site staff to mobilize pumps and empty 215-L drums or other appropriate storage containers to the spill site;
 - iv) deploy on-site staff to build containment dykes and commence pumping contaminant into drums;
 - v) apply absorbent as necessary;
 - vi) dispose of all contaminated debris, cleaning materials and absorbent by burning, if appropriate, or by placing it in an approved land-fill site;
 - vii) take all necessary precautions to ensure that the incident does not recur;
- g) The Project Manager will be responsible for the preparation of a written report which will be sent (as soon as possible and no later than 30 days after the spill) to Anaconda; and, from there to:

Newfoundland and Labrador Department of Government Services
 Government Service Center
 9 Queensway
 Grand Falls-Windsor, NL
 Telephone: (709) 292-4206
 Fax: (709) 292-4528

Graham Thomas
 Environmental Emergencies Coordinator
 Environment Canada
 6 Bruce Street Mount Pearl, NL A1N4T3
 Telephone:
 (709) 772-4285 (Business)
 (709) 687-5634 (Cell)

CONTINGENCY PLAN

Authority:	Operations Manager	Issue Date:	-
Custodian:	Environmental Coordinator	Revision Date:	Oct. 16, 2017
Issuing Department:	Environmental	Document No.:	1.1

9.0 Environmental Effects Monitoring – Pine Cove

9.1 Water Quality Monitoring Program

9.1.1 Effluent Monitoring

Water including drill water, waste rock pile runoff, open pit water, mill process water, tailings water and other water that has the potential to be contaminated, shall be directed to the tailings impoundment area for treatment. However, if AMI can demonstrate that any of the above meet the provincial regulations then the water can be discharged outside of the tailings impoundment area.

AMI will collect water samples from various locations of the tailings impoundment area. Samples will be collected to characterize the quality of the water and to ensure compliance with the appropriate regulations and permit conditions.

Effluent from the mill will initially be contained within the tailings dam area. Suspended solids in the effluent will be reduced via natural settlement before surface water discharge into the polishing pond via the control structure. The rate of release of effluent from the tailings dam area to the polishing pond can be controlled. AMI will employ appropriate measures to prevent surface erosion and siltation during the effluent transfer.

Effluent from the polishing pond will be released into Pine Cove Brook through the control structure. AMI will employ appropriate measures to prevent surface erosion and siltation during the effluent release. Should effluent monitoring indicate that the effluent is non-compliant with the established discharge criteria (see Table 3), AMI will immediately cease the release of the effluent. Effluent discharge will not resume until AMI demonstrates that the water quality is compliant with the established criteria and has approval from the Director.

CONTINGENCY PLAN

Authority:	Operations Manager	Issue Date:	-
Custodian:	Environmental Coordinator	Revision Date:	Oct. 16, 2017
Issuing Department:	Environmental	Document No.:	1.1

Table 3: Effluent Discharge Criteria Limits

Parameter	Maximum Authorized Monthly Mean Concentration	Maximum Authorized Concentration in a Composite Sample	Maximum Authorized Concentration in a Grab Sample
Arsenic	0.50 mg/L	0.75 mg/L	1.00 mg/L
Copper	0.30 mg/L	0.45 mg/L	0.60 mg/L
Cyanide	1.00 mg/L	1.50 mg/L	2.00 mg/L
Lead	0.20 mg/L	0.30 mg/L	0.40 mg/L
Nickel	0.50 mg/L	0.75 mg/L	1.00 mg/L
Zinc	0.50 mg/L	0.75 mg/L	1.00 mg/L
TSS	15.00 mg/L	22.50 mg/L	30.00 mg/L
Radium	226 0.37 Bq/L	0.74 Bq/L	1.11 Bq/L
pH	Allowable Range 5.5 – 9.0 units		
ALT	Toxic pass		

Table 4: Effluent Water Quality Monitoring

Description	EDMS Location Code	Parameters	Frequency
Point Rouse Project Operation Polishing Pond Discharge	00254	Arsenic, Copper, Cyanide*, Lead, Nickel, Zinc, TSS, Radium 226, pH	Weekly (at least 24 hours apart)
Stog'er Tight Operation North Pit Settlement Pond Discharge South Pit Discharge	00640	ALT, TPH	Monthly (at least 15 days apart)
Point Rouse Project Operation Polishing Pond Emergency Spillway	00255	Arsenic, Copper, Cyanide, Lead, Nickel, Zinc, TSS, Radium 226, pH, ALT, TPH	Grab Sample for each overflow event

* Parameter analysis not required for Stog'er Tight Operation

CONTINGENCY PLAN

Authority:	Operations Manager	Issue Date:	-
Custodian:	Environmental Coordinator	Revision Date:	Oct. 16, 2017
Issuing Department:	Environmental	Document No.:	1.1

9.1.2 Surface and Ground Water Monitoring

AMI will collect surface and ground water samples from various locations around the site. Samples will be collected to characterize the quality of the water and to ensure compliance with the appropriate regulations and permit conditions.

Surface water samples will be collected at the same locations during each sampling event and will be field labelled with sample identification and co-ordinates to ensure that sampling integrity is maintained.

Ground water monitoring wells are installed downstream and upstream of the dams in an effort to detect any significant impact on groundwater quality.

Table 5: Surface and Ground Water Quality Monitoring

Location	EDMS Location Code	Parameters
Pine Cove Operation	00499	General Parameters: temperature, dissolved oxygen (DO), nitrate + nitrite, nitrate, nitrite, pH, TSS* , colour, sodium, potassium, calcium, sulphide, magnesium, ammonia, alkalinity, sulphate, chloride, turbidity, reactive silica, orthophosphate, phosphorous, DOC, conductance, TDS (calculated), phenolics, carbonate (CaCO ₃), hardness (CaCO ₃), bicarbonate (CaCO ₃)
Polishing Pond TSF 1	00256	
(Formerly Tailings Pond 1)	00498	
TSF 2 (Tailings Pond 2)	00257	
Pine Cove Brook Pine Cove	00258	
Pond Reference Pond Open	00259	
Pit Water Monitoring Well	00261	
#1 Monitoring Well #4	00262	
Polishing Pond Seepage	00497	
Tailings (TSF 1) Seepage	00500	
Line Make-Up Water	00501	
Return Line Culvert South	00502	
Waste Dump	00503	
Tributary 1	00260	
Stog'er Tight Operation		Metals Scan: aluminium, antimony, arsenic, barium, beryllium, bismuth, boron, cadmium, chromium, cobalt, copper, iron, lead, manganese, molybdenum, mercury, nickel, selenium, silver, strontium, thallium, tin, titanium, uranium, vanadium, zinc.
Station 1 – Fox Pond	00642	
Drainage Station 2 – Fox	00643	
Pond Station 3 – Camp	00644	
Pond Station 4 – Reference	00645	
Pond North Pit Settlement	00640	
Pond South Pit	00641	

CONTINGENCY PLAN

Authority:	Operations Manager	Issue Date:	-
Custodian:	Environmental Coordinator	Revision Date:	Oct. 16, 2017
Issuing Department:	Environmental	Document No.:	1.1

9.2 Analysis and QA/QC

All solids and liquids analysis performed will be completed by a contracted commercial laboratory. The laboratories will have a recognized form of accreditation.

10.0 Contingency Plan Location

This plan is posted at site in the following locations

- Mill Control Room
- Reagent Storage Building
- Site Office
- Emergency Response Center

CONTINGENCY PLAN

Authority:	Operations Manager	Issue Date:	-
Custodian:	Environmental Coordinator	Revision Date:	Oct. 16, 2017
Issuing Department:	Environmental	Document No.:	1.1

**Appendix A
(MSDS)**

CONTINGENCY PLAN

Authority:	Operations Manager	Issue Date:	-
Custodian:	Environmental Coordinator	Revision Date:	Oct. 16, 2017
Issuing Department:	Environmental	Document No.:	1.1

**Appendix B
(Site Plan)**

CONTINGENCY PLAN

Authority:	Operations Manager	Issue Date:	-
Custodian:	Environmental Coordinator	Revision Date:	Oct. 16, 2017
Issuing Department:	Environmental	Document No.:	1.1

Appendix C
(Water Sampling Locations)

CONTINGENCY PLAN

Authority:	Operations Manager	Issue Date:	-
Custodian:	Environmental Coordinator	Revision Date:	Oct. 16, 2017
Issuing Department:	Environmental	Document No.:	1.1

**Appendix D
(Emergency Response Equipment)
Anaconda Mining Inc.**

Internal Response Equipment

- 1 loader
- 3 excavators
- 3 dump trucks
- 2 emergency response spill kits for petroleum
- 2 emergency response spill kits for hazardous materials
- 4 shovels
- 2 rakes
- 10 empty 215 Lt. barrels with lids
- 1 genset emergency generator
- Portable lighting
- Warehouse supplies such as assorted rubber boots, gloves, suits and eye protection
- Haz-mat trained response team

Appendix G

Waste Management Plan – Point Rousse Project

Waste Management Plan

Authority:	Operations Manager	Issue Date:	July, 2008
Custodian:	Environmental Coordinator	Revision Date:	Oct. 24, 2017
Issuing Department:	Environmental	Document No.:	1.1

WASTE MANAGEMENT PLAN

FOR

ANACONDA MINING INC. – POINT ROUSSE PROJECT



Waste Management Plan

Authority:	Operations Manager	Issue Date:	July, 2008
Custodian:	Environmental Coordinator	Revision Date:	Oct. 24, 2017
Issuing Department:	Environmental	Document No.:	1.1

Table of Contents

1.0	Introduction	- 1 -
1.1	Goals and Objectives	- 1 -
1.2	Scope	- 1 -
1.3	Plan Organization	- 2 -
1.4	Document History	- 2 -
2.0	Regulatory Framework	- 2 -
3.0	Wastes Characterization	- 3 -
3.1	Waste Type, Estimated Quantity, Location, and Method of Disposal	- 4 -
3.2	Waste Management Infrastructure	- 4 -
3.3	Waste Handling Practices	- 5 -
3.4	Waste Management Option Identification	- 5 -
4.0	Management Commitment and Structure	- 6 -
4.1	Waste Management Coordinator	- 6 -
4.2	Environmental Coordinator	- 6 -
4.3	Management Layout	- 6 -
4.4	Roles and Responsibilities	- 7 -
5.0	Waste Management Operation Procedures	- 7 -
5.1	Orientation/Awareness Training	- 7 -
5.2	Disposal of Wastes	- 8 -
5.2.1	<i>Waste Storage, Disposal, and Transportation</i>	<i>- 8 -</i>
5.2.2	<i>Waste Diversion and Reduction Programs</i>	<i>- 9 -</i>
5.2.3	<i>Waste Handling</i>	<i>10</i>
5.2.4	<i>Special Waste Handling</i>	<i>14</i>
5.2.5	<i>Waste Transportation</i>	<i>15</i>
5.2.6	<i>Waste Storage</i>	<i>16</i>
5.2.7	Infrastructure and Equipment	16
6.0	Monitoring, Reporting, and Audits	17
6.1	Reporting Problems or Concerns	17
6.2	Record Keeping	17
6.3	Routine Monitoring	18
6.4	Annual Monitoring, Reporting and WMP Revision	18

Appendices

A-1	SITE PLAN	Appendix A
A-2	DECONTAMINATING EMPTY CONTAINERS	Appendix B
A-3	TRIPLE WASH PRICEUDRE	Appendix C

Waste Management Plan

Authority:	Operations Manager	Issue Date:	July, 2008
Custodian:	Environmental Coordinator	Revision Date:	Oct. 24, 2017
Issuing Department:	Environmental	Document No.:	1.1

1.0 EMERGENCY PHONE NUMBERS

<u>Organization</u>	<u>Phone</u>
Baie Verte Peninsula Health Centre	1-709-532-5200
Baie Verte Ambulance	1-709-532-5200
Baie Verte Hospital	1-709-532-5200/4281
Baie Verte RCMP	1-709-532-4221
Baie Verte Fire Department	1-709-532-4400
Ming's Bight Fire Department	1-709-254-7777/7461/6516
La Scie Ambulance	1-709-675-2300
La Scie Medical Clinic	1-709-675-2529
La Scie Fire Department	1-709-675-2429
Department of Transportation - Baie Verte	1-709-292-4444
Ambulance, Police, and Fire	
(St. John's, Gander, Grandfalls-Windsor, & Corner Brook)	911
Emergency Measures Organization	1-709-729-3703
Poison Information Centers	
Corner Brook	1-709-634-7121
Gander	1-709-256-5552
Grand falls-Windsor	1-709-292-2500
St. Anthony	1-709-457-334
St. John's	1-709-722-1110
Department of Environment and Labor	
Information and Concerns	1-800-563-5471
Industrial Accidents Reporting	1-800-563-5471
OHS Industrial Accidents (Direct)	1-709-729-4444
Anaconda Mining -Main Office	
Tony Chislett – General Manager	1-709-532-6490/4159
Jordan Cramm – Mine Superintendent	1-709-297-0011
Linus Doyle – Safety / HR Coordinator / MFSSO	1-709-532-8598/4197
Tony Decker – Environmental Coordinator	1-709-532- 7748
Kevin Rice – Mill Superintendent	1-709-297-1105
Chris Budgell – Process Coordinator	1-709-673-7504
Anaconda Mining – Site Office	1-709-800-7332
Guy J Bailey Ltd. – Main office	1-709-532-4642/8216
Scott Bailey – Manager	1-709-532-7250
Peter Goudie – Site Supervisor	1-709-532-7295
Hillary Burt – Safety Coordinator/MFSSO	1-709-532-4642
Shoreline Aggregates	
Shannon Lewis – Marine Facility Supervisor	1-709-532-7925
NFLD Hard-Rok	
Gerald Bursey – Manger	1-709-660-0516

Waste Management Plan

Authority:	Operations Manager	Issue Date:	July, 2008
Custodian:	Environmental Coordinator	Revision Date:	Oct. 24, 2017
Issuing Department:	Environmental	Document No.:	1.1

2.0 POINT ROUSSE PROJECT FACILITY COMMUNICATIONS

The following flow chart outlines the on-scene-commander and designates in a case where the Project Manager is absent from the site:

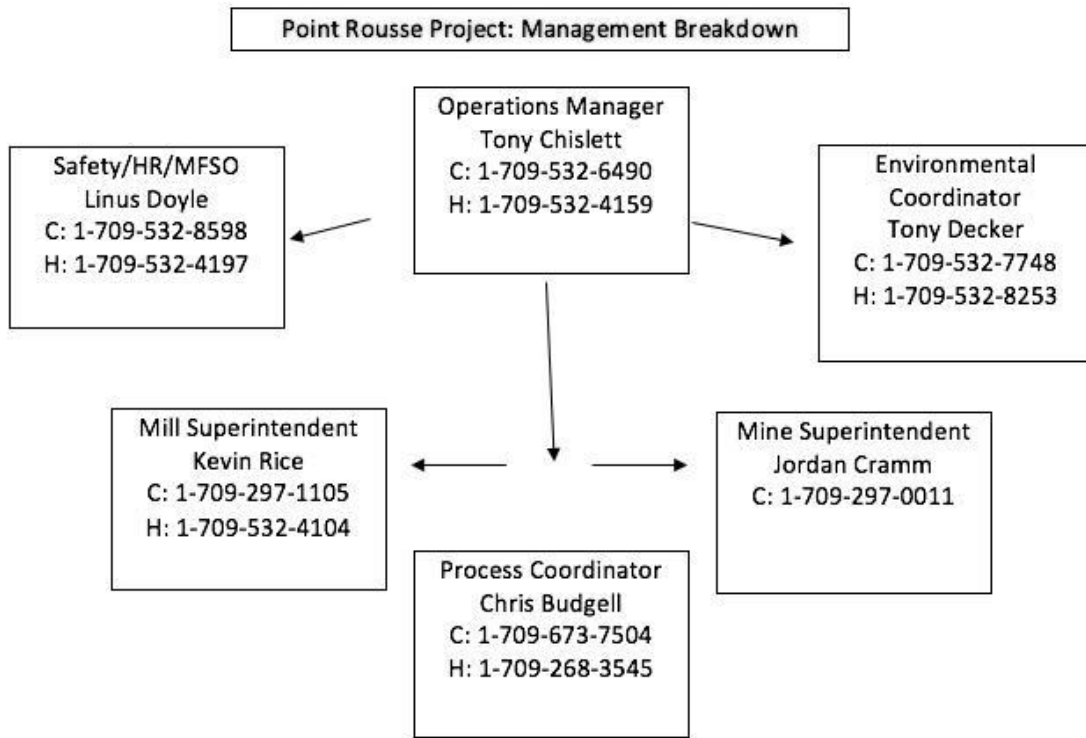

Table 1: Outline of the chain of command

Waste Management Plan

Authority:	Operations Manager	Issue Date:	July, 2008
Custodian:	Environmental Coordinator	Revision Date:	Oct. 24, 2017
Issuing Department:	Environmental	Document No.:	1.1

1.0 Introduction

This Waste Management Plan (WMP) provides direction on waste handling, storage, transport, treatment and disposal of the various wastes produced at the Point Rouse Project. The Plan provides a waste management system, to deal with waste streams and allow for the implementation of reduction and diversion opportunities. The Plan also serves as an internal quality control document that provides clear and concise direction for company staff and contractors regarding waste management policies and procedures that must be followed.

Anaconda Mining Inc. (AMI) has made it a corporate policy to mine resources in the most environmentally responsible manner possible. This policy extends into all aspects of the operation including waste management. As such, waste material deemed industrial, hazardous, or domestic must be dealt with in compliance with governmental legislation. AMI's Waste Disposal Plan incorporates the proper handling, storage, and treatment of wastes created at the Point Rouse Project.

1.1 Goals and Objectives

The objective is to create a plan that integrates all necessary requirements in dealing with all the different types of wastes generated at the Point Rouse Project.

The goal of the plan is to provide detailed information on the proper handling, storage, treatment, and disposal of industrial, hazardous, and domestic type wastes generated at the site by:

- Meeting all municipal, provincial, and federal regulatory requirements for waste management;
- Incorporating and optimizing operational procedures based on the basic principles of waste management including reduce, reuse, recycle, recovery and residual waste disposal; and
- Minimizing adverse effects on the environment.

1.2 Scope

This WMP covers all operations and personnel on the Point Rouse Project including contractors, sub-contractors and consultants. The Plan will address specifically both the mine and mill and will serve as a guide for all other operations. It will provide direction on waste handling, storage, transport, treatment, and disposal. The WMP will address industrial waste, mining wastes such as mine effluent, tailings, and waste rock produced at the site.

Waste Management Plan

Authority:	Operations Manager	Issue Date:	July, 2008
Custodian:	Environmental Coordinator	Revision Date:	Oct. 24, 2017
Issuing Department:	Environmental	Document No.:	1.1

1.3 Plan Organization

Section 1 of this Plan provides the purpose, goals and scope of the Plan. The regulatory framework which provides the basis for the Plan is summarized in *Section 2*. *Sections 3 to 6* details the basic elements of the waste management system including waste characterization, management structure, operational procedures, handling practices and monitoring, reporting and auditing systems.

Much of the information is presented in tabular format which will provide simple, concise listings that can be easily reviewed and updated as part of the annual review of the Plan.

1.4 Document History

Date	Version	Notes
July, 2008	0.1	Prepared by: Jacques Whitford
September 14, 2017	1	Prepared by: Tony Decker/Kyle Burt

Table 2: This table shows the relevant document history

2.0 Regulatory Framework

The foundation of the Waste Management Plan is based on the regulatory framework for industrial waste management in Newfoundland and Labrador including legislation, regulations and guidelines at the federal, provincial and municipal levels.

The principle legislation guiding and governing waste management in Newfoundland and Labrador is the Environmental Protection Act (EPA), assented in 2002, and amended in 2006, which consolidates the previous Environment Act, Environmental Assessment Act, Pesticides Act, Waste Management Act and Waste Material Disposal Act. The EPA covers the technical aspects of waste disposal, including handling, diverting, recovering, recycling, reducing and reusing waste materials. Under the provisions of this legislation, waste materials may be designated for recycling, composting, or reuse and bans may be placed on the disposal of certain wastes.

Waste Management Plan

Authority:	Operations Manager	Issue Date:	July, 2008
Custodian:	Environmental Coordinator	Revision Date:	Oct. 24, 2017
Issuing Department:	Environmental	Document No.:	1.1

Legislation/Guidelines	Section or Reference	Requirements/Comments
Anaconda Mining Inc. operating Certificate of Approval. (No. AA17-08)	Conditions 18-22, 22-23, 28-32 and 36.	Waste management plans, open burning, spill contamination/prevention, and used oil.
Environmental Protection Act (EPA)	Parts IV, V, XII	Covers all aspects of waste disposal, handling, and investigation, etc. and provides for the requirement of this plan.

Table 3: This table identifies the current, applicable requirements that affect this WMP.

3.0 Wastes Characterization

Typically, in order to assess the current and future requirements of a WMP, a qualitative and quantitative assessment or characterization of the waste materials being generated is required. This characterization establishes the baseline conditions and serves as a guide for monitoring and auditing.

In order to ensure that the WMP will remain flexible and responsive to the needs of the waste management systems, reporting, auditing and monitoring procedures will be established.

These procedures will:

- Ensure review, as required, waste quantities and composition for specific waste streams.
- Ensure appropriate infrastructure and equipment are provided for handling waste materials.
- Ensure that the collection frequency of waste materials is appropriate.
- Assist in assessing the feasibility of new waste reduction, diversion and disposal options.

A list of the various waste types, origins, and disposal categories are provided in Table 3 located next in section 3.1.

Waste Management Plan

Authority:	Operations Manager	Issue Date:	July, 2008
Custodian:	Environmental Coordinator	Revision Date:	Oct. 24, 2017
Issuing Department:	Environmental	Document No.:	1.1

3.1 Waste Type, Estimated Quantity, Location, and Method of Disposal

The following table gives a short summary of the classification and estimated quantities of wastes as well as the proposed disposal methods.

Classification of Waste	Estimated Quantity [Monthly]	Method of Disposal
Oil [L]	600	Distributed to local contractors or Crosby Industrial
Metals (Steel and Iron) [lbs]	400	Reduced/Reused Internally/Manual's Recycling
Domestic [1/2 ton pick-up Loads]	8	Ming's Bight Landfill, transitioning to Central Waste, Norris Arm
Lumber (Pallets and Scrap) [Lbs]	600	Reduced/Reused Internally/Ming's Bight Landfill, transitioning to Central Waste, Norris Arm
Hazardous Waste Packaging [Lbs]	200	Triple Washed Ming's Bight Landfill, transitioning to Central Waste, Norris Arm

Table 4: Summary of Anticipated Waste and Disposal Methods

3.2 Waste Management Infrastructure

AMI is committed to the most environmentally and economically sound ways to reduce and better manage waste through source reduction, recycling and reuse.

Only the waste that is deemed to be no longer viable will be disposed of in an appropriate manner.

Waste Management Plan

Authority:	Operations Manager	Issue Date:	July, 2008
Custodian:	Environmental Coordinator	Revision Date:	Oct. 24, 2017
Issuing Department:	Environmental	Document No.:	1.1

3.3 Waste Handling Practices

All waste created at the Point Rouse Project will be handled by trained personnel. Any waste not permitted to be disposed of at an approved landfill site will be stored, when applicable, in sealed storage containers and disposed of in an appropriate manner.

Any materials that can be either reused or recycled will be separated from the waste stream accordingly.

3.4 Waste Management Option Identification

To ensure that AMI's waste management plan is developed and executed accordingly the plan must emphasize the economic and environmental importance of reuse, recycling and source reduction, AMI is developing its waste management plan around these key issues.

A viable option to ensure that the amount of waste created at the Point Rouse Project is reduced, is at the procurement/inventory stage. By using a well-defined procurement and inventory system AMI will reduce the opportunity for excessive ordering and be able to order and maintain materials in a more efficient manner.

Policies of procurement may include (where possible):

- Purchase of products which contain a maximum amount of post-consumer recycled material while retaining product integrity. By doing so AMI is ensuring that any products that are purchased contain at least some recycled material.
- Purchase of remanufactured/reconditioned equipment and vehicles when properly warranted and economically advantageous rather than new purchases wherever possible. By doing so AMI is reducing the amount of new materials that will enter our site. AMI is essentially reusing the materials that are available instead of investing in new.
- Remain current with new technology and techniques. Generally new technology and techniques are more environmentally friendly and as a result will help in waste reduction.

Once materials are purchased and brought to the site the next available option for waste reduction would be to reuse or recycle materials at site. AMI intends to try and reuse or recycle material on site as much as possible to reduce the amount of waste generated.

Waste Management Plan

Authority:	Operations Manager	Issue Date:	July, 2008
Custodian:	Environmental Coordinator	Revision Date:	Oct. 24, 2017
Issuing Department:	Environmental	Document No.:	1.1

4.0 Management Commitment and Structure

AMI is committed to the preservation and protection of our environment. As such, AMI commits to the implementation, maintenance, and upgrading of this WMP which incorporates existing waste management strategies and new initiatives.

AMI's management will assume responsibility of the waste management program. The management personnel will appoint the appropriate employees to form and operate the waste management committee (WMC) which will oversee the execution and operation of the waste management plan.

AMI Operations management recognizes that staff time and resources are required to implement and maintain this Plan. All employees must understand the importance of the Plan and following procedures. The roles and responsibilities of the Waste Management Committee and other staff and outlined below.

4.1 Waste Management Coordinator

The Operations Manager will act as the (*Waste Management Coordinator*) and be responsible for organizing and managing the WMC. In this capacity the Coordinator will also be responsible for delegating any duties required for on-site personnel to keep with the basic principle of the waste management plan which is to reduce the volume of waste exiting the site either by proper purchasing and inventory procedures, reuse or recycling.

4.2 Environmental Coordinator

The Environmental Coordinator will aid in day to day management and review of the WMP initiatives and procedures to ensure that this plan is carried out with a full understanding of the applicable regulations and requirements by other staff members.

4.3 Management Layout

The waste management committee is organized in a flow pattern to maximize efficiency and to maintain organization. This allows for the operation to be followed by everyone.

Waste Management Plan

Authority:	Operations Manager	Issue Date:	July, 2008
Custodian:	Environmental Coordinator	Revision Date:	Oct. 24, 2017
Issuing Department:	Environmental	Document No.:	1.1

4.4 Roles and Responsibilities

The effectiveness of this WMP depends on the commitment and actions of all employees. Therefore, all personnel must be fully aware of their individual duties and responsibilities, as outlined below.

Environmental Coordinator

- Provide day to day guidance on all aspects of waste management activities
- Conduct routine monitoring and/or audits with respect to waste handling, infrastructure and equipment, and contractors
- Provide information to local media on waste initiatives, plans and successes, as appropriate and as approved by the Waste Management Committee.
- Conduct and/or facilitate waste management meetings
- Conduct awareness training for all AMI employees and contractors
- Report any health and safety issues with respect to WMP to Safety Supervisor

Employees

- Must be aware of the waste management requirements specific to his/her area and type of work.

5.0 Waste Management Operation Procedures

5.1 Orientation/Awareness Training

Employee education and awareness about the WMP, and continual communication are important to ensure the success of the Plan. All company staff and contractors/sub-consultants should be informed about the Plan and should know and understand their responsibilities under the Plan. On-going communication about plan implementation, changes, and results will ensure a high level of awareness about the Plan.

Information on waste management and the WMP at AMI operations will be provided to all new employees and contractors/sub-consultants during standard site orientation training. Additional information and training will be provided on an individual basis, specific to the work area of the employee or contractor/sub-consultant. All contractors/sub-consultants will be provided with specific instructions on how to deal with waste disposal at the Point Rouse Project.

Waste Management Plan

Authority:	Operations Manager	Issue Date:	July, 2008
Custodian:	Environmental Coordinator	Revision Date:	Oct. 24, 2017
Issuing Department:	Environmental	Document No.:	1.1

All employees who handle any material waste products that are generated at the Point Rouse Project site will be properly trained in *Dangerous Goods, WHMIS, and/or Emergency First Aid*. This training will allow these employees the capability of handling all types of waste in an environmentally responsible and safe manner. This training will be renewed as required or when necessary to ensure that all members of the WMC remain current with any changes in technologies or procedures that may become available.

5.2 Disposal of Wastes

Off-site disposal includes any waste that is disposed of outside of the Point Rouse Project property. This includes waste material taken off-site to be recycled, reused, incinerated, stored, or sent to an off-site landfill.

5.2.1 Waste Storage, Disposal, and Transportation

Any waste material that is generated at the Point Rouse Project site will be stored until it can be properly disposed of. The following sections outline how the projected types of wastes that will be created, are stored and disposed of from the Point Rouse Project.

5.2.1.1 Waste Oil

All waste oils, lubricants and other used oil from mill machinery on the site will be stored in sealed water tight containers. The waste oil will then be disposed of by a company licensed for handling and disposal of used oil products or transported to an approved waste oil tank owned by a local contractor for recycling.

5.2.1.2 Metals (Steel and Iron)

As with any industrial/ commercial operation there will be some steel and iron used at the Point Rouse Project site. The steel and iron will be used in fabrication and repairs at the site. These resources will be used in an efficient and conservative manner whereas to ensure the least amount of wastage. Any metal that cannot be salvaged or reused will be recycled off site by a company licensed to handle scrap metal.

Waste Management Plan

Authority:	Operations Manager	Issue Date:	July, 2008
Custodian:	Environmental Coordinator	Revision Date:	Oct. 24, 2017
Issuing Department:	Environmental	Document No.:	1.1

5.2.1.3 Domestic Waste

Wastes commonly generated in a household setting will also be created at the Point Rouse Project site. These wastes will be stored on site and removed on a weekly basis by site personnel to the local Ming's Bight municipal landfill.

5.2.1.4 Lumber (Pallets and Scrap)

Most of the bulk products used at the Point Rouse Project arrive at site on pallets. These pallets will be either sent back to the distributor, sold, recycled or reused at site. If the lumber is no longer salvageable then it will be disposed of at the Ming's Bight municipal landfill.

5.2.1.5 Hazardous Waste Packaging

Dependent upon the characterization of the material they once contained, empty containers or inner liners maybe considered non-hazardous and be suitable for disposal in an approved landfill site, subject to the permission of the operator/owner. Regulation defines an "empty container" as a container from which waste's and other materials have been removed, using removal practices such as pumping, or pouring and which contains less than 2.5 centimeters of material on the bottom of the container.

AMI will employ a triple wash procedure for all reagent containers and packaging to ensure any acute hazardous waste residue is removed prior to disposal at the Ming's Bight municipal landfill. See appendix C for Triple Wash Procedure.

5.2.2 Waste Diversion and Reduction Programs

Waste diversion and reduction programs are necessary to optimize the reduction of waste materials, the cost of purchased materials and the return, rebate, and sales of recyclable or reusable material. AMI's Lean and Green Team manage and review all aspects of waste reduction and diversion practices on a continual basis. This review will, at a minimum cover the following wastes and aspects of waste:

Waste Management Plan

Authority:	Operations Manager	Issue Date:	July, 2008
Custodian:	Environmental Coordinator	Revision Date:	Oct. 24, 2017
Issuing Department:	Environmental	Document No.:	1.1

- | | |
|--|--|
| <u>Wastes</u>
1) Energy
2) Water
3) Materials
4) Transportation
5) Garbage
6) Emissions
7) Biodiversity | <u>Aspects of wastes</u>
1) Purchasing practices
2) Packaging materials
3) Supplier rebates
4) Recycling or reuse returns and rebates
5) Potential partnerships |
|--|--|

Waste reduction, diversion options and considerations will be managed through Lean and Green team initiatives. Objectives and targets are set at meetings and progress is kept through meeting minutes. Progress requires the development and implementation of plans and clearly assigned responsibilities and guided activities by AMI personnel. All objectives and targets regarding waste reduction and/or diversion will be listed and updated at each successive meeting.

5.2.3 Waste Handling

Waste handling covers all aspects of waste sorting, transportation and storage of common waste as well as special wastes at the A M I Operations. A summary of the general waste handling procedures including collection, storage and transportation practices are provided in Table 5.

Waste Management Plan

Authority:	Operations Manager	Issue Date:	July, 2008
Custodian:	Environmental Coordinator	Revision Date:	Oct. 24, 2017
Issuing Department:	Environmental	Document No.:	1.1

Category	Waste Type	Collection and Transport	Initial Storage location	Final Collection and Transport
General	Domestic	AMI Personnel/Contractors	Temporary Bins	Ming's Bight Landfill
	Electronics	AMI Personnel/Contractors	Sea Can	Central Waste Management Facility
	Ink Cartridges/Toner	AMI Personnel/Contractors	Sea Can	Central Office Equipment
Plastics and Rubber	Plastic Pails	AMI Personnel/Contractors	Laydown Area	Reuse/Ming's Bight Landfill/Crosby Industrial
	Conveyor Belts	AMI Personnel/Contractors	Laydown Area	Reuse/Recycle or Sold
	Used Tires	AMI Personnel/Contractors	Contractor Laydown Area	Reconditioned onsite/ Remain at offsite service station for disposal
	Plastic Bottles	AMI Personnel/Contractors	Temporary bins	Recycled BV Fire Dept.
Glass	Windows (Damaged/Broken)	AMI Personnel/Contractors	Temporary bins	Ming's Bight Landfill
	Bottles	AMI Personnel/Contractors	Temporary bins	Recycled BV Fire Dept.
Wood and Paper	Pallets	AMI Personnel/Contractors	Laydown Area	Reused/Recycled/Sold
	Scrap Wood	AMI Personnel/Contractors	Laydown Area	Ming's Bight Landfill
	Cardboard	AMI Personnel	Temporary bins	Ming's Bight Landfill

Waste Management Plan

Authority:	Operations Manager	Issue Date:	July, 2008
Custodian:	Environmental Coordinator	Revision Date:	Oct. 24, 2017
Issuing Department:	Environmental	Document No.:	1.1

Category	Waste Type	Collection and Transport	Initial Storage location	Final Collection and Transport
Metals	Scrap	AMI Personnel/Contractors	GJB Laydown Area	Manual's Recycling
	Aluminum Cans	AMI Personnel/Contractors	Temporary bins	Recycled BV Fire Dept.
Hazardous Materials	Totes	AMI Personnel	Onsite	Newalta
	Lab Chemicals	AMI Personnel	Onsite	Onsite/ Certified hazard waste disposal company
	Batteries	AMI Personnel/Contractors	Off-site Service Station	Remain at offsite service station for disposal
	Aerosol Cans	AMI Personnel	Onsite	Newalta/ CleanHarbor
	Bulbs	AMI Personnel	Temporary Bins	Ming's Bight Landfill
	Reagent Bags	AMI Personnel	Laydown Area	Ming's Bight Landfill
	Paint and other Toxic Products	AMI Personnel	Onsite	Newalta/ CleanHarbor

Waste Management Plan

Authority:	Operations Manager	Issue Date:	July, 2008
Custodian:	Environmental Coordinator	Revision Date:	Oct. 24, 2017
Issuing Department:	Environmental	Document No.:	1.1

Category	Waste Type	Collection and Transport	Initial Storage location	Final Collection and Transport
Hydrocarbon Material	Fuel and oil filters	AMI Personnel	Onsite	Crosby Industrial
	Solvent/Oil Contaminated Material	AMI Personnel	Onsite	Crosby Industrial
	Fuel contaminated soil	AMI Personnel	Onsite	Crosby Industrial
	Waste grease	AMI Personnel	Onsite	Crosby Industrial
	Solvents and oils	AMI Personnel	Onsite	Crosby Industrial
	Antifreeze	AMI Personnel	Onsite	Crosby Industrial
	Oil/Lube Totes	AMI Personnel	Onsite	Crosby Industrial
	Used Oil	AMI Personnel	Onsite	Crosby Industrial

Table 5: A summary of waste handling procedures.

- Waste handling procedures shall conform to all existing or new internal and external regulations and policies as identified in this WMP or that come into effect prior to revision of this Plan.
- Handling of waste related to an employee's specific line of work should be conducted by the employee as required within his/her normal duties. Depending on the waste type and method of storage, proper training and/or instruction and orientation may be required to ensure that the procedures as outlined in this Plan are followed.
- Handling of special, hazardous or hydrocarbon waste should only be conducted by personnel trained in all aspects of handling, transportation and storage of the material or materials.

Waste Management Plan

Authority:	Operations Manager	Issue Date:	July, 2008
Custodian:	Environmental Coordinator	Revision Date:	Oct. 24, 2017
Issuing Department:	Environmental	Document No.:	1.1

5.2.4 Special Waste Handling

- Special wastes are wastes that must be handled to ensure that the material does not cause contamination, fire or affect the health of personnel. Special wastes may include hydrocarbon, hazardous or any other waste that, when not handled properly, induce additional risk to personnel or property.
- Special wastes must be handled by employees trained to complete this work or a licensed waste disposal contractor.
- Solid waste to be recycled/incinerated should be separately binned and/or stored in temporary containers until final storage.

These wastes include:

- Non-punctured Aerosol cans
- Lithium/NiCad batteries
- Bulbs (fluorescent, halogen, etc.)
- Plastic drums (totes and bags) containing contaminant residues
- Liquid and liquid contaminated wastes to be recycled/incinerated should be drummed or put in **approved** containers **ensuring no mixing** of materials. These wastes include:
 - Fuel and oil filters
 - Solvent/oil contaminated rags, workwear, absorbent pads and materials
 - Oil
 - Paint and other toxic products containers
 - Grease tubes
 - Waste grease
 - Solvents/oils
 - Laboratory Chemicals
 - Antifreeze

Waste Management Plan

Authority:	Operations Manager	Issue Date:	July, 2008
Custodian:	Environmental Coordinator	Revision Date:	Oct. 24, 2017
Issuing Department:	Environmental	Document No.:	1.1

- For drum storage of waste, the following practices must be followed. Drummed waste is stored indoors or in a properly dyked and protected storage area. The drums must be clearly labelled indicating their contents and that materials are not mixed. See comments below regarding handling and storage requirements.
 - Full Drums:
 - Labelling - Drums must have proper labelling (MSDS available where applicable)
 - Storage - On pallets and in designated areas protected from damage and properly ventilated
 - Movement - Verify drum is tightly closed
 - Multiple drums should be secured on a pallet before moving
 - Single Drums should be strapped
 - In-Use Drum:
 - Labelling - Drums must have proper labelling (MSDS available where applicable)
 - Storage - In designated areas protected from damage and properly ventilated
 - Movement - Verify drum is tightly closed
 - Decanting - Ensure decanting nozzle does not have leak when installed
 - Use with a drip pan to prevent spills, keep clean-up material near by
 - Use properly labelled decanting containers (do not mix products)

5.2.5 Waste Transportation

- Transportation of waste may include:
 - Movement of waste from a work area to the appropriate disposal or storage area.
 - Movement of waste from a temporary disposal or storage area to the landfill, bulk storage area or off-site.
 - Movement of waste from a bulk storage area or laydown area to off-site.
- Movement of common or routine waste from a work area to the appropriate disposal or storage area should be completed by the employee. The employee should be aware of the type of waste and the proper handling and transportation procedures specific to that type of waste.

Waste Management Plan

Authority:	Operations Manager	Issue Date:	July, 2008
Custodian:	Environmental Coordinator	Revision Date:	Oct. 24, 2017
Issuing Department:	Environmental	Document No.:	1.1

- Movement from a temporary disposal or storage area to a bulk storage area or off-site should be completed by waste handling personnel (unless additional employees or contractors are designated). Movement of such materials should be conducted using appropriate equipment while utilizing appropriate personal protective equipment (PPE) at all times.

5.2.6 Waste Storage

Waste storage applies to on-site temporary pallets, bins, laydown areas and bulk storage areas:

- All waste should be stored at the designated location in/on approved containers, pallets or laydown areas, and be dyked if applicable.
- Storage areas/containers are to be clearly marked and located at approved locations around the site based on the waste requirements of each area.
- Waste placed at laydown areas or stored in containers will be collected at appropriate intervals to avoid spillage, overflow or congestion.
- Bulk storage areas will be maintained to ensure safety, maximization of available space and access for waste haulers to all adjacent areas.
- Storage areas will be inspected and reviewed based on space, necessity, access, etc. as required or at a minimum, annually.
- The hydrocarbon and hazardous waste containment area must be properly maintained and inspected to ensure full access, proper storage procedures and early leak or spill detection.
- Used oil storage containers must be inspected and maintained on monthly basis.
- All records of inspections must be submitted to the Environmental Coordinator.

5.2.7 Infrastructure and Equipment

Waste management infrastructure and equipment includes any or all infrastructure and equipment related to handling, transportation, storage or removal of wastes from the site. All waste management infrastructure and equipment must be maintained to ensure the health and safety of employees and avoid contamination or degradation of waste during storage or transportation.

Waste Management Plan

Authority:	Operations Manager	Issue Date:	July, 2008
Custodian:	Environmental Coordinator	Revision Date:	Oct. 24, 2017
Issuing Department:	Environmental	Document No.:	1.1

6.0 Monitoring, Reporting, and Audits

Continual review and enhancement of the Waste Management Plan will be conducted with a goal of continuous improvement. The purpose of monitoring and auditing the waste management system is to identify any problems or aspects of the plan that can be improved, and to determine appropriate actions to address these issues.

6.1 Reporting Problems or Concerns

All AMI Operations employees and contractors/sub-consultants are responsible and encouraged to report problems or concerns related to any aspect of this WMP.

Issues pertaining to training, waste handling, transportation, storage, infrastructure and equipment should be reported to the Waste Management Coordinator. Any appropriate issues will be reviewed and acted on or, if necessary, reviewed by Management. A record will be kept of all problems or concerns that are identified.

Any environmental issues or questions will be directed to:

Director
Pollution Prevention Division
Department of Municipal Affairs and Environment
(709) 729-5782

6.2 Record Keeping

Records related to the AMI Operations waste management system will be kept by the Waste Management Coordinator.

Waste Management Plan

Authority:	Operations Manager	Issue Date:	July, 2008
Custodian:	Environmental Coordinator	Revision Date:	Oct. 24, 2017
Issuing Department:	Environmental	Document No.:	1.1

Records may include documents and information related to:

- orientation and waste management training
- waste characterization
- waste management legislation, regulations and guidelines
- waste management contractors
- off-site waste disposal
- Inspections of waste storage facilities and
- any other aspects or issues related to the waste management system

6.3 Routine Monitoring

Routine monitoring of waste management activities will be conducted to ensure that the guidelines and procedures outlined in this plan are being followed. Routine monitoring may consist of informal or formal checks on personnel, equipment and contractors and review of records related to waste management activities.

Monitoring may include:

- Location and condition of on-site waste and recycling collection bins.
- Condition and organization of waste laydown and storage areas.
- Waste collection, transportation and handling operations for AMI employees and waste management contractors.
- Waste volumes from mine areas.
- Any other aspects or issues related to the waste management system.

6.4 Annual Monitoring, Reporting and WMP Revision

This plan will be reviewed annually or as necessary to ensure that all components of the plan are current and operating properly. The review of the plan will be conducted by the Environmental Coordinator.

Waste Management Plan

Authority:	Operations Manager	Issue Date:	July, 2008
Custodian:	Environmental Coordinator	Revision Date:	Oct. 24, 2017
Issuing Department:	Environmental	Document No.:	1.1

The review of the plan should include the following:

- existing, new and upcoming changes in legislation, regulations and guidelines;
- existing and potential waste diversion and reduction programs; and
- operational procedures, equipment and infrastructure.

Monitoring of some components of the waste management system may be required prior to or as a result of the formal review process. If monitoring is required as a result of the review, an additional formal review may be required where changes to the WMP are necessary.

Revision of the WMP may only be completed with the approval of Management. Personnel affected by any revisions or changes should be notified and their training updated if necessary. Revisions or changes in the WMP should also be updated in the waste management orientation and operations training.

Waste Management Plan

Authority:	Operations Manager	Issue Date:	July, 2008
Custodian:	Environmental Coordinator	Revision Date:	Oct. 24, 2017
Issuing Department:	Environmental	Document No.:	1.1

APPENDIX A
A-1 SITE PLAN

Waste Management Plan

Authority:	Operations Manager	Issue Date:	July, 2008
Custodian:	Environmental Coordinator	Revision Date:	Oct. 24, 2017
Issuing Department:	Environmental	Document No.:	1.1



Waste Management Plan

Authority:	Operations Manager	Issue Date:	July, 2008
Custodian:	Environmental Coordinator	Revision Date:	Oct. 24, 2017
Issuing Department:	Environmental	Document No.:	1.1

APPENDIX B
A-2 DECONTAMINATING EMPTY CONTAINERS

Waste Management Plan

Authority:	Operations Manager	Issue Date:	July, 2008
Custodian:	Environmental Coordinator	Revision Date:	Oct. 24, 2017
Issuing Department:	Environmental	Document No.:	1.1

Decontaminating Empty Containers

Solvents

Water soluble solvents: Rinse twice with water, then completely fill the container with water and empty it to displace vapors. Allow to drain. Before disposing of the container, remove the lid and write "EMPTY" or "MT" on the label. Dispose of empty containers as regular trash.

Solvents not soluble in water: Wash with a detergent or rinse twice with a water-soluble solvent such as acetone, then fill the container with water and empty it to displace vapors. Allow it to drain. Solvents (other than water) used for cleaning must be collected and disposed as chemical waste; they cannot go down the drain. Before disposing of the container, remove the lid and write "EMPTY" or "MT" on the label. Dispose of empty containers as regular trash.

Acids

Neutralize the liquid residues using sodium or potassium carbonate or bicarbonate. Rinse several times with water. The rinse water may be disposed of down the drain. Before disposing of the container, remove the lid and write "EMPTY" or "MT" on the label. Dispose of empty containers as regular trash.

Bases

Neutralize the liquid residues using citric acid. Rinse several times with water. The rinse water may be poured down the drain. Before disposing of the container, remove the lid and write "EMPTY" or "MT" on the label. Dispose of empty containers as regular trash.

Other Liquids

Rinse the container twice with water, then fill the container with water and empty it to displace vapors. Allow the container to drain. Rinse water may be poured down the drain. Before disposing of the container, remove the lid and write "EMPTY" or "MT" on the label. Dispose of empty containers as regular trash.

Solids

Water soluble chemicals: Rinse twice with water, then completely fill the container with water and empty it. Allow the container to drain. Before disposing of the container, remove the lid and write "EMPTY" or "MT" on the label. Dispose of empty containers as regular trash.

Organic material not soluble in water: Wash with a detergent or rinse twice with a water-soluble solvent such as acetone, then completely fill the container with water and empty it. Allow it to drain. Solvents (other than water) used for cleaning must be collected and disposed as chemical waste; they cannot go down the drain. Before disposing of the container, remove the lid and write "EMPTY" or "MT" on the label. Dispose of empty containers as regular trash.

Waste Management Plan

Authority:	Operations Manager	Issue Date:	July, 2008
Custodian:	Environmental Coordinator	Revision Date:	Oct. 24, 2017
Issuing Department:	Environmental	Document No.:	1.1

APPENDIX C
A-3 TRIPLE WASH PROCEDURE

Waste Management Plan

Authority:	Operations Manager	Issue Date:	July, 2008
Custodian:	Environmental Coordinator	Revision Date:	Oct. 24, 2017
Issuing Department:	Environmental	Document No.:	1.1

Triple Wash Procedure

PPE required: Safety Glasses, Nitrile Gloves, Disposable Cover-All's, Negative Pressure Half-Faced Mask

Reagents required: None

Wash Preparation: Fill double compartment sink using reclaim water to fill line

1. Place reagent packaging into first compartment of sink.
2. Submerge packaging and agitate using stir rod.
3. Agitate and allow 1-minute soak.
4. Transfer reagent packaging into second compartment.
5. Repeat steps 2 & 3.
6. Drain waste water from sink compartments into floor sump leaving reagent packaging in second compartment
7. Inspect reagent packaging for any signs of residual reagent and perform final rinse using wash down hose.
8. Any signs of residual reagent remain, repeat procedure.
9. Remove reagent packaging from sink and transfer to compactor.

Always remember to wear appropriate PPE

Appendix H

Environmental Protection Plan – Point Rouse Project

Authority:	Operations Manager	Issue Date:	November 1, 2017
Custodian:	Environmental Coordinator	Revision Date:	March 13, 2018
Issuing Department:	Environmental	Document No.:	1.3

TABLE OF CONTENTS

1. INTRODUCTION4

1.1 Purpose of the EPP4

1.2 Organization of the EPP5

1.3 Environmental Orientation5

1.4 Anaconda’s Environmental Policy.....6

1.5 Project Description8

1.5.1 Mine/Mill Construction Activities9

1.5.1.1 Access9

1.5.1.2 Power Supply9

1.5.1.3 Accommodations.....10

1.5.1.4 Mine Pit10

1.1.5.5 Mill Facility.....10

1.1.5.6 Maintenance Building/Office Facilities11

1.1.5.7 Ore Stockpile11

1.1.5.8 Tailings Disposal11

1.1.5.9 New Tailings and Polishing Pond14

1.5.1.10 Organic Stockpiles.....16

1.1.5.11 Waste Rock Stockpile16

1.1.5.12 Lower Grade Ore Stockpile.....16

1.5.2 Operation Activities17

1.5.2.1 Mining of Open Pit.....17

1.5.2.2 Processing18

1.5.2.3 Rock Quality18

1.5.2.4 Life of Mine19

1.5.2.5 Mine Closure19

2. Environmental Protection Procedures20

2.1 Surveying21

Authority:	Operations Manager	Issue Date:	November 1, 2017
Custodian:	Environmental Coordinator	Revision Date:	March 13, 2018
Issuing Department:	Environmental	Document No.:	1.3

2.2	Clearing Vegetation	22
2.3	Grubbing and Disposal of Related Debris.....	24
2.4	Buffer Zones.....	25
2.5	Environmental Concerns.....	26
2.6	Water Supply	26
2.7	Site Drainage.....	27
2.8	Concrete Production/Placement	28
2.9	Trenching.....	28
2.10	Dewatering – Work Areas.....	29
2.11	Excavation, Embankment and Grading.....	30
2.12	Blasting on Land	31
2.13	Blasting near Water.....	32
2.14	Drilling – Exploration or Geotechnical	33
2.15	Watercourse (Stream) Crossing.....	34
2.16	Storage, Handling and Transfer of Fuel and Other Hazardous Material.....	37
2.17	Solid Waste Disposal	40
2.18	Sewage Disposal.....	40
2.19	Mine Water/Waste Water Treatment.....	41
2.20	Dust Control.....	44
2.21	Noise Control	44
2.22	Equipment Use and Maintenance	44
2.23	Pumps and Generators	45
2.24	Vehicle Traffic, including ATV and Snowmobile Traffic.....	46
2.25	Tailings Dam Inspection.....	46
2.26	Hazardous Waste Disposal.....	47
2.27	Marshalling and Storage Areas	48
3	Contingency Plan	50
3.1	Fuel and Hazardous Material Spills	51
3.2	Wildlife Encounters	53
3.3	Discovery of Historic Resources	54

Authority:	Operations Manager	Issue Date:	November 1, 2017
Custodian:	Environmental Coordinator	Revision Date:	March 13, 2018
Issuing Department:	Environmental	Document No.:	1.3

3.4	Forest Fires	54
3.5	Mine Safety and First Aid.....	55
4	Contact List	56
5	Permits, Approvals and Authorizations.....	57
6	Literature Cited	59
6.1	Response Sequence.....	59

Authority:	Operations Manager	Issue Date:	November 1, 2017
Custodian:	Environmental Coordinator	Revision Date:	March 13, 2018
Issuing Department:	Environmental	Document No.:	1.3

1. INTRODUCTION

1.1 Purpose of the EPP

Environmental protection planning is an important component of overall project planning and implementation for mining projects. Environmental Protection Plans (EPPs) are commonly required as part of a project approval by governments following the environmental assessment stage of the project planning, and before construction and/or development occurs. EPPs provide a practical way in which proponents can demonstrate understanding of environmental regulations, and document practices and procedures required to minimize or eliminate potential environmental impacts resulting from the project.

Anaconda Mining Inc. (Anaconda) has committed to the development and implementation of a comprehensive EPP. This will help ensure a high level of environmental protection throughout its work area and activities associated with the continued exploration and mine development of the Point Rouse Project. An EPP is a working document for use in the field for both project personnel and the Project Manager (who will be the on-site person in charge of the Project), as well as at the corporate level for ensuring commitments made in policy statements are implemented and monitored. EPPs provide a quick reference for project personnel and regulators to monitor compliance and to make suggestions for improvements.

EPPs typically undergo many revisions for complex and dynamic activities such as mine/mill operations and exploration activities and, as such, this EPP is structured to allow for updates and revisions as work continues.

This EPP provides the protection procedures for the routine activities associated with mine/mill operational activities. The EPP forms an integral part of the overall environmental management planning approach by Anaconda. Other aspects of environmental management planning include compliance monitoring, reporting, environmental effects monitoring, employee orientation, and liaisons with governments, communities and interest groups.

The purpose of the EPP is to:

- Ensure that commitments to minimize environmental impacts will be met;
- Document environmental concerns and appropriate production measures;
- Provide concise and clear instructions to project personnel regarding procedures for protecting the environment and minimizing environmental impact;
- Provide a reference document for personnel when planning and/or conducting specific activities;
- Provide a training aid during implementation efforts;
- Communicate changes in the program through revision process; and
- Provide a reference to applicable legislative requirements

Authority:	Operations Manager	Issue Date:	November 1, 2017
Custodian:	Environmental Coordinator	Revision Date:	March 13, 2018
Issuing Department:	Environmental	Document No.:	1.3

1.2 Organization of the EPP

This EPP provides instructions to ensure project personnel understand and implement environmental protection procedures for both routine activities and unplanned events associated with mine/mill operations at the Point Rouse Project.

The style and format of the EPP is intended to enhance its use by project personnel in the field. It is also to provide an overview of the proposed project, detailed procedures related to environmental protection, contacts, and a summary of permits and authorizations required for specific project components and activities.

The EPP comprises the following sections:

The *Preface* provides the distribution records of the EPP.

- Section 1* Introduces the EPP. This section also provides the reader with Anaconda's Environmental Policy, a Project Description as well as a site map.
- Section 2* describes the environmental concerns and general environmental protection procedures.
- Section 3* provides response instructions to project personnel for unplanned events.
- Section 4* describes environmental compliance monitoring responsibilities and procedures.
- Section 5* provides an outline of abandonment/rehabilitation plans.
- Section 6* contains a list of key projects, regulatory and community contacts for the environmental team to enhance the implementation of the EPP.
- Section 7* provides a list of potential permits, approvals and authorizations that may be necessary for various activities during mine/mill operations.
- Section 8* is a listing of references cited throughout the EPP. These references should be consulted for more detailed discussions than those provided in the text.

1.3 Environmental Orientation

Anaconda is committed to an active environmental orientation and ongoing environmental awareness program throughout its mine/mill operations. Where possible, all workers will receive a brief environmental orientation from the Project Manager or environmental support staff prior to initiating any work at the Point Rouse Project.

An Environmental Orientation Program will be developed on a continuing basis during the design and construction phase. The orientation will be for specific contractors and specific employees as appropriate. There will not be any orientation for visitors. The orientation session will be specific to the tasks to be performed by contractors but will be comprehensive for permanent employees (where relevant) and will include the following contingency plans, in addition to those detailed in Section 3:

Authority:	Operations Manager	Issue Date:	November 1, 2017
Custodian:	Environmental Coordinator	Revision Date:	March 13, 2018
Issuing Department:	Environmental	Document No.:	1.3

- Procedure in case of an Environmental Emergency (general communication line)
- Procedure in case of fire
- Procedure in case of an unplanned effluent release
- Procedure in case of a reagent spill

1.4 Anaconda’s Environmental Policy

The Board of Directors of Anaconda has established a corporate environmental policy that guides the actions of the company and is followed and promoted by employees and contractors, hired by the company. This policy is a part of the overall corporate governance policy. It is regularly monitored for compliance with appropriate reviews to ensure effective implementation.

Authority:	Operations Manager	Issue Date:	November 1, 2017
Custodian:	Environmental Coordinator	Revision Date:	March 13, 2018
Issuing Department:	Environmental	Document No.:	1.3

ENVIRONMENTAL POLICY

"ANACONDA MINING INC."

Anaconda Mining Inc. is fully committed to environmentally responsible development and will ensure that all phases of it's projects will follow this approach to resource development through the following actions:

- Ensure that environmental management planning is carried out for all aspects of the project including minimisation of impacts, waste management and pollution prevention;
- Compliance with federal and state/provincial environmental legislation, standards, codes of compliance and permit requirements;
- Monitor the performance of environmental management programs and strategies through performance indicators and metrics to facilitate continuous improvement;
- Develop, design and operate facilities in a way that minimises impacts to the environment through best practice, awareness, resource reduction and environmental protection;
- Identify, asses and manage environmental risks;
- Develop, maintain and test emergency preparedness plans to ensure the protection of the employees and the environment;
- Require Contractors and Consultants to comply with Company environmental requirements and to monitor and continually improve their environmental performance;
- Promote environmental awareness through training and communication to Employees and Contractors about environmental management, compliance and risk management; and
- Ensure that closure and reclamation planning is integrated into mine feasibility planning and that there are adequate resources available to deal with closure at all phases of the project.

Anaconda Mining Inc. will communicate this policy to it's Employees, Contractors, Consultants and the Public and maintain an open forum for review and continual improvement to the policy's commitments and strategies.

Name: Dustin Angelo

Position: President & CEO

Signature

Date

Authority:	Operations Manager	Issue Date:	November 1, 2017
Custodian:	Environmental Coordinator	Revision Date:	March 13, 2018
Issuing Department:	Environmental	Document No.:	1.3

1.5 Project Description

The Point Rouse Project (“the Property”), which contains the Pine Cove Deposit, is in the Ming’s Bight area of the Baie Verte peninsula of Newfoundland. The Property is currently 100% owned by Anaconda Mining Inc.

The Pine Cove property lies on the Point Rouse Peninsula, in the northern portion of the Baie Verte Peninsula, approximately 6 km northeast of the Town of Baie Verte in north-central Newfoundland (Figure 1). The Baie Verte Peninsula coastline is rugged and highly irregular, with cliffs and steep slopes prevailing. On the Pine Cove property, moderate to steep slopes above Baie Verte rise to a maximum elevation of 120 m, averaging 60 to 70 m above sea level. Ponds and small lakes are common, the largest being Green Cove and Scrape Ponds. Vegetation consists of mature spruce and fir, largely cutover, with regrowth of alder, birch, and young fir. Alders are prevalent in older stripped and wet areas.

The Feasibility Study, completed by A.C.A. Howe International Limited in December 2004 and revised in March 2005, based the assessment on a seven (7) year mine life (1,000 tonnes per day) with a probable reserve of 2,332,676 tonnes at an average grade of 2.76 g/t Au. After the submission of the Feasibility Study (March 2005), additional financial analysis had indicated a strong project advantage to adjusting the plant size to a 500 tpd operation with an expected production life cycle of 15 years. More recently, however, and based on mill expansion, updated financial analyses and reserve estimates of 2010, the project has been optimized for a 1,000 tpd processing rate and a production life cycle of 8 years.

Anaconda did propose to develop a 365,000 tonne per year open pit mine and mill operation (1,000 tpd) at the Pine Cove Deposit. In addition to the open pit, the major features and facilities associated with the Project are as follows:

- The plant site, complete with a 1,000 tpd flotation mill with concentrate leaching, shops, warehouse, transformer station, water supply, sewage and mine water treatment facilities, emergency backup power, ancillary roads and minor structures;
- Overburden, low grade ore, and waste rock dumps;
- An engineered Tailings Dam and associated spillway, decant and embankment structures including reclaim water systems;
- An engineered Polishing Pond and associated dam, spillway, and decant structure; and
- A diversion channel and the relocation of Pine Cove Brook to accommodate the Open Pit location.

The Project design is based on the application of best available engineering and industry practice to the design of mining, processing, and recovery of gold. This is being achieved through the application of proven engineering concepts and technology to mining, milling, and waste management. Anaconda has completed all necessary environmental permitting. Construction of the gold mine began in July 2007 as was followed by initial production in May 2008.

Authority:	Operations Manager	Issue Date:	November 1, 2017
Custodian:	Environmental Coordinator	Revision Date:	March 13, 2018
Issuing Department:	Environmental	Document No.:	1.3

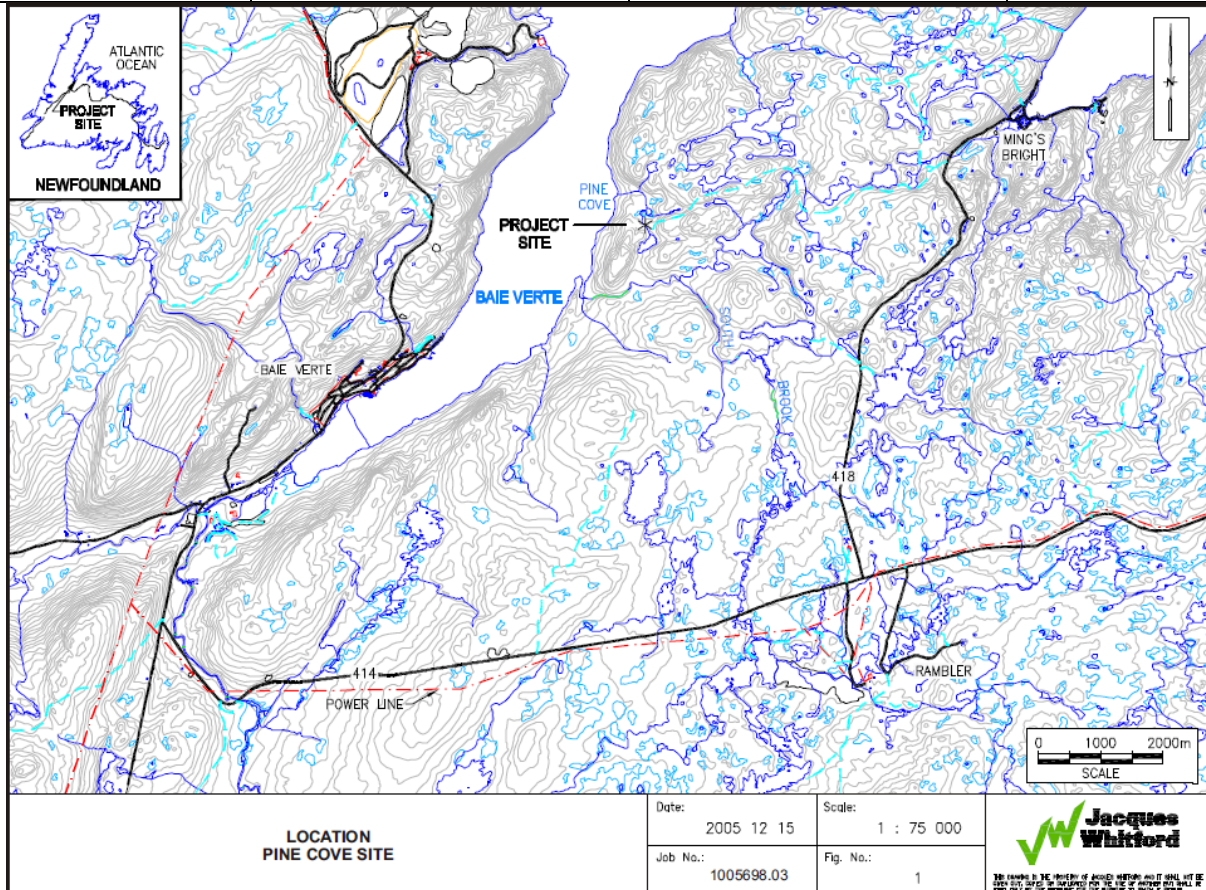

Figure 1 - Project Site Location Relative to Baie Verte Peninsula

1.5.1 Mine/Mill Construction Activities

The following features are illustrated in Figure 2.

1.5.1.1 Access

The property is accessible by the Pine Cove Resource Road off the Ming's Bight Road (Highway 418). Pine Cove Road is maintained by Anaconda and has recently been upgraded to support the movement of heavy equipment. Locally available fill and rock (non-acid generating) has been used for road upgrading.

1.5.1.2 Power Supply

An on-site diesel generator will be installed to provide power to the mine/mill.

Authority:	Operations Manager	Issue Date:	November 1, 2017
Custodian:	Environmental Coordinator	Revision Date:	March 13, 2018
Issuing Department:	Environmental	Document No.:	1.3

1.5.1.3 Accommodations

The work force will be housed off-site and no permanent accommodations will exist during construction or operation of the proposed project.

1.5.1.4 Mine Pit

The mine is being developed as an open pit with a total area, at surface, of approximately 9.8 hectares when production is complete. The pit will reach a maximum depth of 150 m along the south wall. At the start of the fiscal 2015 year (June 1st, 2014), it is anticipated that there will be 1,500,000 tons of ore, and 7,900,000 tons of waste for a total of 9,400,000 tons of material.

To date, the Pine Cove Pit has produced approximately 1.3 million tons of ore, and 5.2 million tons of waste for a total production of approximately 6.5 million tons of material.

In January 2014, Knight Piesold conducted a slope stability analysis, out of which new pit slope designs were agreed on. Mining is still carried out in 6m benches and overall bench heights of 18m remain the same with the original design. Changes occur in the bench width, inter-ramp angle and overall pit slope angle. Changes to the pit design were done to incorporate structural constraints within the pit limit. The result of this analysis was the creation of 3 sectors, each with their own specification. The North, South, and Southern extension sectors each have overall pit wall angles of 55°, 51° and 46° respectively.

Pit main access ramps are designed at a –10% gradient to accommodate rear wheel drive haulage trucks. The width of these ramps is designed at 15.0 meters to facilitate two-way truck traffic at all points, if the production haulage truck would be a John Deere 460D unit with a 46-ton capacity. Final pit bottom access ramps are designed at a gradient of –10% and a width of 10 meters to accommodate one-way traffic between the 4940 m elevation (mine datum, Geodetic + 5000 m) and the pit bottom. The last pit bench at 4904 m elevation (mine datum) will be excavated primarily with a back-hoe due to the steep temporary access ramp on broken ore and minimal working space.

Consideration was given always in the design process to issues regarding existing topography, haulage roads, waste dump locations and drainage areas. During the design process, consideration was also given to providing adequate operational space requirements for equipment in areas approaching final design pit walls.

1.1.5.5 Mill Facility

The mill facility is located on gently sloping ground to the east of the pit. It will be composed of a crushing building, a concentrate building using grinding, and flotation processes, and an isolated leaching area with an impermeable floor with a raised perimeter lip to contain any spills. The mill facility is located at a higher elevation than the tailings area to aid in the handling of tailings. The site has been graded to provide the level surface required for operations. Offices, lunchroom, and shower areas are located on the mezzanine level of the Mill building.

Authority:	Operations Manager	Issue Date:	November 1, 2017
Custodian:	Environmental Coordinator	Revision Date:	March 13, 2018
Issuing Department:	Environmental	Document No.:	1.3

Additional offices, equipment storage, etc. are provided by a trailer, originally used during mine construction, located east of the mill.

Three stock piles are located near/within the mill area:

- A 40,000-ton Low Grade Ore Stockpile will be maintained on the slope to the southwest of the mill facility as further described below.
- A 10,000-ton Ore Stockpile will be maintained to the east side of the crusher. This stockpile will be used to ensure production rates if the mining rate is not sufficient or is interrupted.
- A 1,000 ton “live” ore stockpile of crushed material will be maintained in a silo, immediately west of the mill.

1.1.5.6 Maintenance Building/Office Facilities

A building to serve as a maintenance garage and warehouse for the owner’s use will be constructed northeast of the mill building. The building will be wood frame construction on a floating concrete slab foundation. The exterior walls will be clad with vinyl siding and the roof covered aluminum roofing.

The initial office on site was a converted modular home modified into an office, lunchroom, and dry facility. Once construction was completed this was converted into a safety response and office area. August 2014 this structure underwent a final modification and was converted into a site dry for Anaconda mill and pit employees.

The current office building is 2 additional modular units with a total area of 207m². It should be noted that there are still offices located in the second floor of the mill building as well.

1.1.5.7 Ore Stockpile

The ore stockpile will be constructed on an impervious pad of compacted till material, occupying an area of approximately 1 ha. The stockpile is intended to provide storage of ore (10,000 tons) for up to two weeks of mill production. Drainage collected from precipitation will be directed along with site drainage to the conditioning pond described below.

1.1.5.8 Tailings Disposal

Tailings from concentrate production and gold separation will be combined in a mixing tank at the mill and pumped to the Tailings Impoundment located approximately 200 m north of the mill area (Figure 2). The tailings line is currently set up for the tailings to be end spilled, but the option to be spouted into the impoundment area is also available. From here, the effluent is retained for sufficient time to allow settlement of most fine solids particles. The clearer water near the surface of the pond is decanted utilizing a decant tower designed to operate at variable effluent levels over the operational life of the Tailings Impoundment.

Authority:	Operations Manager	Issue Date:	November 1, 2017
Custodian:	Environmental Coordinator	Revision Date:	March 13, 2018
Issuing Department:	Environmental	Document No.:	1.3

The original ultimate Tailings Impoundment (raise to 106 elevation) has been designed to accommodate approximately 1.8 million cubic meters of tailings with an estimated depositional dry density of 1.3 tons per cubic meter. This value is based on a slurry delivery of 31.4% solids and assumes no desiccation or consolidation of the delivered solids. If consolidation occurs the depositional void ratio will decrease, and the associated dry density could rise to 1.5 to 1.7 t/m³, however in the absence of confirmatory data (actual tailings samples) the Development Plan action has been to apply a conservative estimate. The depositional estimate is used for sizing the potential tailings impoundment area for feasibility level evaluation and a conservative estimate is most prudent at this stage.

The tailings discharge to the Tailings Impoundment is not anticipated to contain any significant chemistry. Cyanide used within the leaching circuit (barren solution release) will be removed via the Inco process cyanide destruction unit (or similar technology) at the mill prior to release to the Tailings Impoundment. Suspended solids will be reduced using settlement in the tailings pond and surface water discharge at the decant tower. Residual cyanide values may exist after final rinse in the process and could be present in minute levels in the tailings, however this level is anticipated to be well below regulatory limits and will be further diluted in the pond volume, so are not anticipated to be of either short term or long-term concern. Discharge levels of total suspended solids (TSS) can be controlled at the decant structure and will be maintained near the design and permit limit prior to discharge to the Polishing Pond.

Based on the testing completed to date, no acid rock generation (ARD) issues are anticipated within the tailings deposit.

In March 2014, Anaconda awarded Knight Piésold Ltd. (KP) the design work to complete an expansion of the existing TSF to extend the life of the facility by approximately 18 months. It is anticipated that another TSF will be constructed for storage of the remaining tailings and that Anaconda will put the expanded TSF into closure within the next five years.

The current TSF has a maximum crest at El. 98 m with a lined basin and has been in operation since 2006. The upstream embankment is lined with a 60 mil HDPE geomembrane. Water is decanted from the TSF to the Polishing Pond before being released to the environment (when acceptable to do so). On-going mining will require an expansion of the existing TSF capacity. A preliminary design was completed by KP for a 5 m high downstream embankment raise and can be found in the Technical Specifications (KP Ref. No. VA14-00918). The specifications for this dam construction are consistent with all work which has been completed in prior dam phases. Currently, tailings dam expansion is under the way with estimated completion date at the end of November of 2014. Expanded tailings dam geometry is summarized in the Table 1.

Authority:	Operations Manager	Issue Date:	November 1, 2017
Custodian:	Environmental Coordinator	Revision Date:	March 13, 2018
Issuing Department:	Environmental	Document No.:	1.3

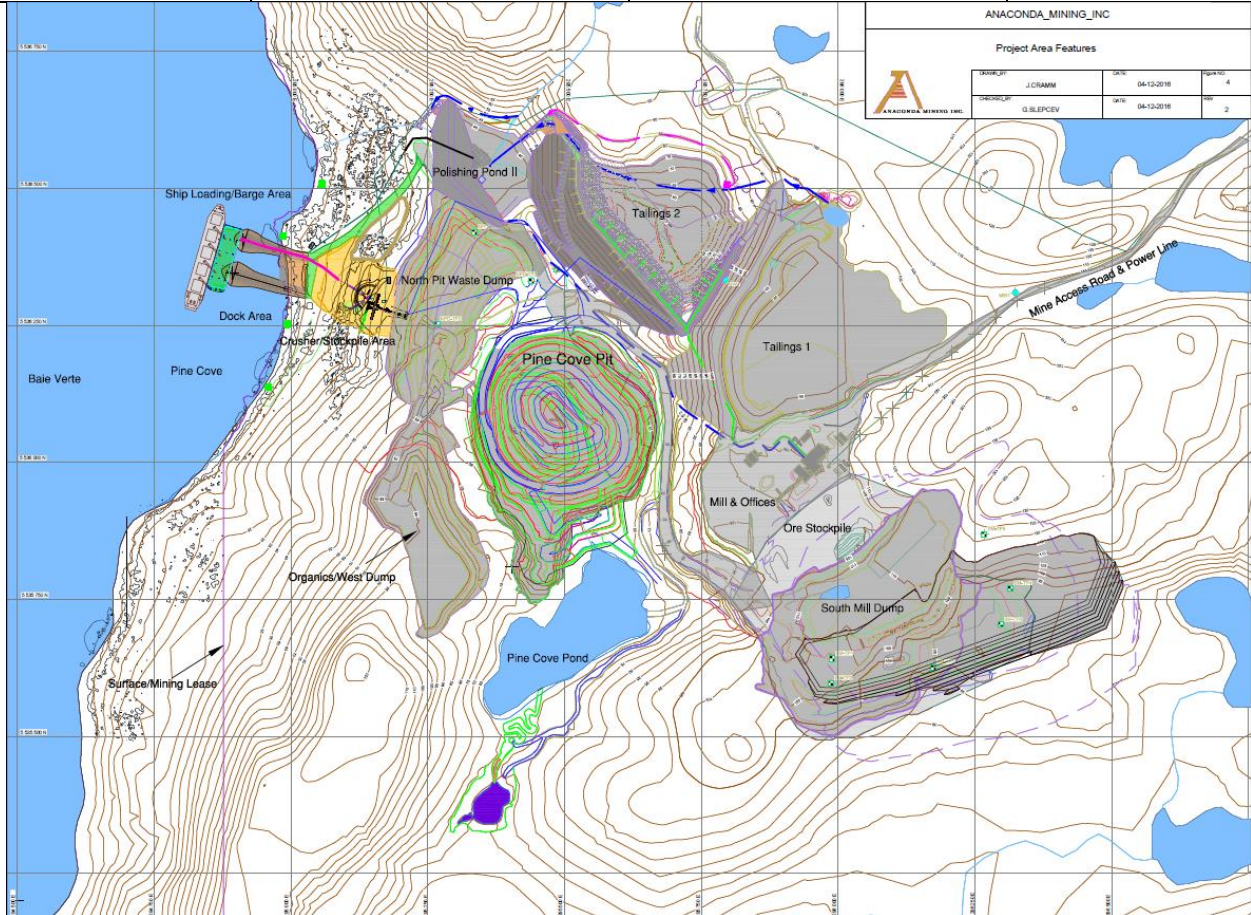

Figure 2 - Pine Cove Site Layout

Authority:	Operations Manager	Issue Date:	November 1, 2017
Custodian:	Environmental Coordinator	Revision Date:	March 13, 2018
Issuing Department:	Environmental	Document No.:	1.3

Table 1 - Summary of 2014 Tailings Pond Dam Geometry

ITEM	SOURCE	DESIGN CRITERIA
Current crest elevation	Anaconda	98 m
Expansion crest elevation	KP	103 m
Expansion maximum embankment height	KP	41 m
Expansion Crest width	KP	8 m
Expansion embankment Length (along centerline)	KP	790 m
Existing upstream slope	Anaconda	3H:1V
Existing downstream slope ¹	Anaconda	1.6-2H:1V
Design upstream slope	KP	2H:1V
Design downstream slope ¹	KP	1.6-2H:1V
Embankment expansion method	KP	Downstream
Primary construction material	KP	Waste rock
Hydraulic liner	KP	60 mil HDPE geomembrane
Bedding layer material	KP	Compacted till sourced from proposed borrow locations
Waste rock material volume ²	KP	227,000 m ³
Till material volume ²	KP	3,000 m ³
Impounded volume ³	KP	500,000 m ³

Tailings dam expansion to 103 el. would not be sufficient to hold life of the mine tailings. Anaconda would need to build another facility that can contain up to 1,000,000m³ or approximately 1,5Mt of tailings. Anaconda is currently investigating number of the options and has been conducting consultation with number of government agencies to proceed with the option that has minimal impact on the environment and possibly stay within already disturbed areas.

1.1.5.9 New Tailings and Polishing Pond

Anaconda Mining Inc. is currently planning for the expansion of their tailings storage as the current tailings storage facility ("TSF") is only sufficient for one half year of milling. Through the communications with Department of Environment, Pollution Prevention and the Department of Natural Resources, it was determined that the preferred option would be to construct a new tailings facility above the existing Polishing Pond. This option would require Anaconda to construct a new Polishing Pond west and downstream of the existing Polishing Pond. This new facility will be used to collect and settle tailings decant water prior to release in to the environment. To accommodate this infrastructure at the Pine Cove Mine a section of the tributary draining in to Pine Cove Brook & Pine Cove Brook itself will need to be re-routed. This new Polishing Pond construction will be finalized by end of May of 2016 when Anaconda plans to start using this new pond to discharge the tailings overflow for settling and retention until the tests prove that the water is of acceptable quality to be released to environment (as per current practice). This would require moving the existing MMER Discharge point from:

Authority:	Operations Manager	Issue Date:	November 1, 2017
Custodian:	Environmental Coordinator	Revision Date:	March 13, 2018
Issuing Department:	Environmental	Document No.:	1.3

From:

Latitude: 49° 57' 53" N

Longitude: 56° 7' 26" W

To:

Latitude: 49° 58' 00" N

Longitude: 56° 08' 00" W

The new FDP is approximately 185meters away from the bay.

The new TSF has been designed to be constructed in the area already outlined as a waste storage area in the Development, Rehabilitation and Closure plan submitted by Anaconda prior to mining in 2006.

Knight–Piesold, an engineering firm, has prepared the construction design of the Tailings II storage facility which will be located above the existing Polishing Pond and 50 metres away from the Pine Cove pit. Figure 2 shows the conceptual locations of the proposed new TSF and new Polishing Pond. It is estimated that the new TSF will be required in late spring/early summer of 2016.

Phase II storage capacity is 0.8M cubic metres or 1.0M tonnes.

The Phase II TSF will consist of a valley impoundment of the existing Phase I TSF. A geomembrane-lined rockfill embankment will be constructed along the southwest side of the TSF. The geomembrane will be tied into the dense glacial till foundation soils, like the existing TSF embankment, to minimize seepage from the facility. The Phase II embankment will be initially constructed to an interim crest elevation of 72 metres. The embankment will ultimately have raised using downstream construction to a final crest elevation of 83metres.

Summary of North Pit Waste Rock Dump Geometry:

- Maximum Elevation = 83.0 m
- Maximum Height¹ = 40 m
- Maximum Freeboard – 2 m
- Crest width – 10 m
- Interim Crest width – 8 m
- Downstream Slope = 2H:1V (overall); Between Ramps 1.8H:1V
- Upstream Slope = 2.5H:1V

The new tailings and Polishing Pond area will be progressively cleared and grubbed prior to placement of waste rock material. The waste rock is not expected to produce any chemistry in the runoff but, if required, small settling ponds will be constructed to manage suspended solids. The waste rock materials have been sampled from

Authority:	Operations Manager	Issue Date:	November 1, 2017
Custodian:	Environmental Coordinator	Revision Date:	March 13, 2018
Issuing Department:	Environmental	Document No.:	1.3

exploration borehole and trench sample materials and tested for acid rock generation potential. No ARD potential is indicated as further described in Section 8.3 of 2010 Development plan or recent testing of existing tailings send.

1.5.1.10 Organic Stockpiles

Overburden and organic materials cleared from the Open Pit, Waste Rock Pile, and other developed areas have been stockpiled at strategic locations around the site. The size and location of these stockpiles have minimized land disturbance, while optimizing the availability of these materials for progressive rehabilitation and closure activities. No special foundation preparations for these low-rise piles are anticipated.

1.1.5.11 Waste Rock Stockpile

An interim waste rock pile was constructed west of the west wall of the open pit during the winter of 2009/2010. This dump has a storage capacity of approximately 1 million m³ while maintaining safe slopes and has been graded to allow for progressive rehabilitation and natural re-vegetation. Condemnation drilling was completed prior to the establishment of the dump.

The main Waste Rock Pile is located southeast of the plant site. Access to the dump will be provided via the haulage road that runs south of the mill. The Waste Rock Pile has a capacity of at least 6 million m³ while maintaining safe slopes. When required, dozers and/or excavators will be employed to manage and shape the dump. Slopes will be graded as required to allow for progressive rehabilitation and natural re-vegetation.

A site investigation was conducted by a qualified Knight Piesold engineer in November 2013. This investigation gathered information with which could be used to determine the stability of a rock storage area in the vicinity. Detailed soil logging and grab samples were also conducted. Subsequent diamond drilling was also conducted to determine the underlying geology, and to prove there was no material of economic worth in the area. In all, the area was deemed to meet the long-term stability requirements for the life of the mine, as stated in the conclusions of Knight Piesold's report, Stability Analysis of the Proposed North Pit and South Mill Phase II Expansion Waste Dumps (report number VA101-535/31), and approval was also given from the Minister, dated April 1, 2014.

1.1.5.12 Lower Grade Ore Stockpile

A low-grade ore stockpile is located on the slope to the southwest of the mill site. The low-grade ore stockpile is used to store lower grade ore that is considered marginally economic to mill at the time it is mined. The material will be milled if or when economic or processing conditions improve or if there is a disruption in the supply of higher grade ore to the mill.

The stockpile currently has a footprint of approximately 0.2 ha with a planned ultimate footprint of approximately 1.0 ha and when required, dozers and/or excavators will be employed to manage and shape the stockpile. Drainage from the stockpile is collected and directed to an effluent discharge stream where it is handled with other mine effluent prior to release.

Authority:	Operations Manager	Issue Date:	November 1, 2017
Custodian:	Environmental Coordinator	Revision Date:	March 13, 2018
Issuing Department:	Environmental	Document No.:	1.3

1.5.2 Operation Activities

1.5.2.1 Mining of Open Pit

The mine is being developed as an open pit with a total area, at surface, of approximately 9.8 hectares when production is complete. The pit will reach a maximum depth of 150 m along the south wall. At the start of the fiscal 2015 year (June 1st, 2014), it is anticipated that there will be 1,500,000 tons of ore, and 7,900,000 tons of waste for a total of 9,400,000 tons of material.

To date, the Pine Cove Pit has produced approximately 1.3 million tons of ore, and 5.2 million tons of waste for a total production of approximately 6.5 million tons of material.

In January 2014, Knight Piesold conducted a slope stability analysis, out of which new pit slope designs were agreed on. Mining is still carried out in 6m lifts and overall bench heights of 18m remain the same with the original design. Changes occur in the bench width, inter-ramp angle and overall pit slope angle. Changes to the pit design were done to incorporate structural constraints within the pit limit. The result of this analysis was the creation of 3 sectors, each with their own specification. The North, South, and Southern extension sectors each have overall pit wall angles of 55°, 51° and 46° respectively.

Pit main access ramps are designed at a –10% gradient to accommodate rear wheel drive haulage trucks. The width of these ramps is designed at 15.0 meters to facilitate two-way truck traffic at all points, if the production haulage truck would be a John Deere 460D unit with a 46-ton capacity. Final pit bottom access ramps are designed at a gradient of –10% and a width of 10 meters to accommodate one-way traffic between the 4940 m elevation (mine datum, Geodetic + 5000 m) and the pit bottom. The last pit bench at 4904 m elevation (mine datum) will be excavated primarily with a back-hoe due to the steep temporary access ramp on broken ore and minimal working space.

Consideration was given always in the design process to issues regarding existing topography, haulage roads, waste dump locations and drainage areas. During the design process, consideration was also given to providing adequate operational space requirements for equipment in areas approaching final design pit walls.

Authority:	Operations Manager	Issue Date:	November 1, 2017
Custodian:	Environmental Coordinator	Revision Date:	March 13, 2018
Issuing Department:	Environmental	Document No.:	1.3

1.5.2.2 Processing

Crushing

The processing of the ore will follow a two-stage crushing circuit. A primary jaw crusher will reduce run of mine ore down to 50 mm (2 inches). Ore from primary crushing will be further reduced in a secondary cone crusher, the discharge of which will be a nominal 12 mm (1/2 inch) diameter. A double-deck vibrating screen operates in closed circuit with the cone-crusher. Minus 12 mm (1/2 inch) ore will be fed by belt conveyor to a covered storage facility. A belt feeder, in conjunction with a front-end loader, will withdraw or to feed the milling facility.

Milling

In 2005, review of options for the mill design along with metallurgical test work resulted in the consideration of further milling alternatives. As a result, the equipment selection and design process was put on hold until sufficient data could be obtained and impacts to the overall project could be considered.

The original mill design was undertaken by Dan Mackie and Associates with suitable subcontractors as required, including Gekko Systems of Australia, which provided inline jigging equipment and structures. Metallurgical work was carried out by SGS Laboratories at Lakefield, Ontario and this testing was under the supervision and direction of Dan Mackie and Associates. The original design based on the Gekko system did not work. Glenn Kosick and Glenn Dobby were contracted to redesign the concentrator using grinding and flotation up front and utilizing the existing leach and downstream processes.

Leaching

The leach plant will be on a concrete base with raised edges that will be designed to contain any potential spill from equipment or circuit piping. Leaching will be conducted in five agitated tanks, using a dilute cyanide solution, modulated to a pH of at least 10.0. Tailing will be filtered and washed in a pair of vacuum drum filters.

Residue from the system will be washed and detoxified to less than 1 ppm WAD cyanide using air, copper sulfate as catalyst, and sodium metabisulphite with lime as required for pH control.

Burnt or hydrated lime will be used for pH control in the leaching circuit to guarantee a pH of 10 or higher. Sodium cyanide will be used as a lixivate to leach the gold from the solution. Detoxification of cyanided concentrate tailings will be completed with sodium metabisulphite and compressed (diffused) air used as an oxidant with a copper sulfate catalyst. The reagent storage area will have an impermeable floor and raised lip to contain a potential spill or leakage.

1.5.2.3 Rock Quality

Preliminary testing of 36 samples including waste rock, low grade ore (<5% pyrite) and high-grade ore (>5%pyrite) has been conducted using material gathered during earlier diamond drilling programs. Waste rock is not considered PAG based on neutralization potential/acid production potential (NP/AP) generally >50. The NP/AP

Authority:	Operations Manager	Issue Date:	November 1, 2017
Custodian:	Environmental Coordinator	Revision Date:	March 13, 2018
Issuing Department:	Environmental	Document No.:	1.3

ratio of low grade ore was 10 to 50 and not considered PAG. High grade ore has NP/AP ratios from 1.3 to 11. PAG material will be identified using static, kinetic and field tests during operation. High grade ore, minus the extracted gold, will be deposited as tailings in the tailings management area.

1.5.2.4 Life of Mine

Based on current knowledge of the mineable reserves, and diamond drill core data, processing of the ore from the pit will be completed in approximately 7-12 years. This does not consider the potential of other ore bodies on the site or in the area.

Activities related to operating the Point Rousse Project include:

- drilling and blasting;
- operation of mill facility;
- transportation and vehicle operation;
- waste handling, storage and disposal;
- water supply;
- mine water/waste water treatment;
- dewatering;
- reagent storage;
- sewage and grey water disposal;
- dust control;
- equipment usage and maintenance;
- pumps and generators;
- tailings dam inspection;
- fuel and other hazardous materials transportation, handling and storage; and,
- water management

1.5.2.5 Mine Closure

The life of the mine is currently projected to be 7-12 years with a potential for extension based on further reserves being identified. A comprehensive plan for closure will be submitted to DNR – Mines Branch for approval before mining commences. Also, an acceptable financial assurance to cover closure costs will be provided before the start of mining.

Authority:	Operations Manager	Issue Date:	November 1, 2017
Custodian:	Environmental Coordinator	Revision Date:	March 13, 2018
Issuing Department:	Environmental	Document No.:	1.3

2. Environmental Protection Procedures

Section 2 provides environmental protection procedures for activities associated with the construction and operation of the Pine Cove Gold Mine.

- 2.1 Surveying
- 2.2 Clearing Vegetation
- 2.3 Grubbing and Disposal of Related Debris
- 2.4 Buffer Zones
- 2.5 Erosion Prevention
- 2.6 Water Supply
- 2.7 Site Drainage
- 2.8 Concrete Production/Placement
- 2.9 Trenching
- 2.10 Dewatering – Work Areas
- 2.11 Excavation, Embankment and Grading
- 2.12 Blasting on Land
- 2.13 Blasting near Water
- 2.14 Drilling – Exploration, Geotechnical, or Water Well
- 2.15 Watercourse (Stream) Crossings
- 2.16 Storage, Handling and Transfer of Fuel and Other Hazardous Materials
- 2.17 Solid Waste Disposal
- 2.18 Sewage Disposal
- 2.19 Mine Water/Waste Water Treatment
- 2.20 Dust Control
- 2.21 Noise Control
- 2.22 Equipment Use and Maintenance
- 2.23 Pumps and Generators
- 2.24 Vehicle Traffic, including ATV and Snowmobile Traffic
- 2.25 Tailings Dam Construction and Inspections
- 2.26 Hazardous Waste Disposal
- 2.27 Marshalling and Storage Areas

Authority:	Operations Manager	Issue Date:	November 1, 2017
Custodian:	Environmental Coordinator	Revision Date:	March 13, 2018
Issuing Department:	Environmental	Document No.:	1.3

2.1 Surveying

Surveying activities may include:

- land definition
- vegetation removal; and,
- traversing.

Environmental Concerns

Surveying activities may disturb wildlife species, vegetation and historic resources.

Environmental Protection Procedures

Vegetation Removal

- a) Width of survey lines will be limited to that which is necessary for line of sight and unobstructed passage.
- b) Whenever possible, cutting lines to the boundary between treed and open areas will be avoided.
- c) Trees and shrubs will be cut flush with the ground wherever possible.
- d) Cutting of survey lines will be kept to a minimum. Where possible, alternate areas not requiring cut lines will be used.
- e) All trees not exactly on transit lines shall be left standing.
- f) When surveying construction layouts, areas that will be cleared require a modified adherence to the above, except trees, shrubs and areas to be saved or left natural as noted on the plans or marked in the field.
- g) No attempt to harass or disturb wildlife will be made by any person.
- h) Vehicles will yield the right-of-way to wildlife.
- i) There will be no cutting in areas designated as sensitive without notification and approval of the Project Manager.
- j) Archaeological sites and features will not be disturbed during survey work. Any historic resource discoveries will be reported to the Culture and Heritage Division (see Section 3.3).

Authority:	Operations Manager	Issue Date:	November 1, 2017
Custodian:	Environmental Coordinator	Revision Date:	March 13, 2018
Issuing Department:	Environmental	Document No.:	1.3

Traversing

- a) All-terrain vehicles (ATVs) will not be allowed off the right-of-way except as approved by the Project Manager. The use of ATVs will be restricted to designated trails, thus minimizing ground disturbance. ATV use will comply with the Motorized Snow Mobile and All-Terrain Vehicle Regulations, 1996 under the *Motorized Snow Mobile and All-Terrain Vehicle Act* and the Environmental Guidelines for Stream Crossings by All-Terrain Vehicles issued by the Department of Environment and Conservation.
- b) No attempt to harass or disturb wildlife will be made by any person.
- c) No motorized vehicles will enter the areas designated as sensitive without notification and approval of the Project Manager.
- d) The extent of activities in sensitive areas such as wetlands will be minimized wherever possible.
- e) Walking in sensitive areas will be restricted to established walking paths, if available.

2.2 Clearing Vegetation

Environmental Concerns

Commercial harvesting was conducted in the area in the 1990s. Any required vegetation clearing (e.g., trees and shrubs) will be required in advance of surveying, building construction and other site preparation activities. Concerns include the uncontrolled burning of slash and piling of vegetation in or near watercourses, and encounters with historic resources.

Damage to silviculture treated forest management sites in the area will have future economic impacts on the forest resource and are subject to compensation to the Crown.

Environmental Procedures

Measures will be implemented to minimize the potential effects of vegetation removal. Clearing activities will be limited to those areas that are required for exploration, mine and site infrastructure, and will comply with the requirements of all applicable permits, including the Commercial Cutting Permit, the Operating Permit and the Permit to Burn from the Newfoundland and Labrador Department of Natural Resources, Local Forest Management Unit.

- a) A cutting permit will be obtained prior to the start of any additional required site clearing. Clearing or removal of trees will be restricted to the minimum areas needed for the site and stockpiles.

Authority:	Operations Manager	Issue Date:	November 1, 2017
Custodian:	Environmental Coordinator	Revision Date:	March 13, 2018
Issuing Department:	Environmental	Document No.:	1.3

- b) Clearing will consist of cutting to within 150 mm of the ground and disposing of all standing trees, as well as the removal of all shrubs, debris and other perishable materials from the area indicated on the engineering/survey drawings.
- c) All slash will be piled for subsequent disposal.
- d) Only those areas designated on drawings will be cleared. Trees will be blazed at intervals in advance of clearing to demarcate the limits of the work. Blazed trees will not be felled. Clearing activities will not remove any trees outside the authorized clearing widths.
- e) Disposal of cleared un-merchantable timber, slash and cuttings by burning will follow the Forest Fire Regulations, 1996 under the *Forestry Act*, Environmental Code of Practice for Open Burning and the Permit to Burn (from the Newfoundland and Labrador Department of Natural Resources). At no time will a fire be left unattended.
- f) Slash and any other construction material or debris will not be permitted to enter any watercourse. These materials will be piled above spring flood levels.
- g) Hand-held equipment will be used in clearing vegetation except where alternative methods or equipment are approved by the Department of Natural resources. The use of mechanical clearing methods, such as bulldozer, will not occur except where it can be demonstrated that there is no merchantable timber (as defined by the DNR-Forest Resources), and where the resulting terrain disturbance and erosion will not result in the loss of topsoil or the sedimentation of watercourses and waterbodies. Also, where possible a buffer zone of 15 m from the high-water mark will be established in areas where clearing of vegetation is an activity within the vicinity of a waterbody. The limit of clearing will be flagged to delineate buffer zones near waterbodies.
- h) Where possible the buffer will be increased to 20 m of undisturbed vegetation between construction areas and all waterbodies. The limit of clearing will be flagged to delineate buffer zones near waterbodies.
- i) Timber shall be felled inward toward the work area to avoid damaging any standing trees within the immediate work area.
- j) Workers will not destroy or disturb any features such as tent frames consisting of cut poles placed in a rectangular arrangement to hold a tent cover. Such features are indicative of a cultural or archaeological site and should be avoided until a report has been made to the Culture and Heritage Division and clearance to proceed has been received (see Section 3.3).
- k) The area within the tailings area will be cleared of all merchantable timber but other vegetation (brush and small trees) will be left in place.

Authority:	Operations Manager	Issue Date:	November 1, 2017
Custodian:	Environmental Coordinator	Revision Date:	March 13, 2018
Issuing Department:	Environmental	Document No.:	1.3

- l) If the nest of any bird is encountered during vegetation clearing, it is not to be disturbed until the young have fledged and departed. Activities near the nest will be curtailed until the District Forest Resources office is contacted and appropriate mitigation is applied.
- m) Damage to silviculture treated forest management sites in the area is to be avoided if possible. These areas will be identified to site personnel and areas adjacent to site development areas will be flagged to indicate silviculture areas to be protected from cutting and other disturbance. If damage to silviculture treated areas is unavoidable, Anaconda will negotiate compensation to the Crown prior to any forest permits being issued.

2.3 Grubbing and Disposal of Related Debris

Environmental Concerns

The principle concerns associated with grubbing and disposal of related debris are the potential impacts on freshwater ecosystems and water quality.

Environmental Protection Procedures

Measures undertaken to minimize impact on aquatic habitat and resources are as follows:

- a) Grubbing of the organic vegetation mat and/or the upper soil horizons will be minimized and left in place where possible.
- b) The organic vegetation mat and upper soil horizon material, which has been grubbed, will be spread in a manner, which attempts to cover exposed areas. Any surplus of such material will be stored or stockpiled for site rehabilitation and re-vegetation purposes elsewhere in the project area. Topsoil will be stockpiled separately from the overburden. The location of the stockpiles will be recorded and accessible for future rehabilitation purposes.
- c) Measures will be implemented to minimize and control runoff of sediment-laden water during grubbing, or the re-spreading and stockpiling of grubbed materials. Where grubbed materials are re-spread or stockpiled, as many stumps and roots as possible will be left on the ground surface to maintain soil cohesion, to dissipate the energy of runoff, and promote natural re-vegetation. Erosion control measures will be implemented in areas prone to soil loss; these measures could include brush cover, stone riprap, wire mesh, small settling/catchment basins, and drainage channels.
- d) The length of time that grubbed areas will be left exposed to the natural elements will be minimized to prevent unnecessary erosion. Provision will be made to intercept drainage from grubbed areas and treat as required using check dams, straw bales, or filter fabric.
- e) Grubbing activities will be avoided in areas of high slope(s) near watercourses. Where possible, a buffer zone of 20 m will be maintained between grubbed areas and watercourses. Grubbing limits adjacent to watercourses will be flagged in the field.

Authority:	Operations Manager	Issue Date:	November 1, 2017
Custodian:	Environmental Coordinator	Revision Date:	March 13, 2018
Issuing Department:	Environmental	Document No.:	1.3

- f) During grubbing, care will be taken to ensure that grubbed material will not be pushed into areas that are to be left undisturbed.

2.4 Buffer Zones

Environmental Concerns

Buffer zones are essential boundaries for water bodies. Without adequate buffer zone vegetation, streams, ponds and lakes can become laden with silt run-off. Vegetation also provides cover for fish.

Environmental Protection Procedures

- a) Where possible, a vegetated buffer zone of 15 m is to be maintained between construction areas and all waterbodies. The limit of clearing will be flagged to delineate buffer zones near waterbodies.
- b) Silt runoff control fences and check dams will be constructed at the toe of the slope outside the buffer zone when required to control runoff from areas of exposed soils towards waterbodies. Silt fences, check dams and buffer strips will be inspected on a regular basis by the Project Manager. Any accumulations of silt should be removed and disposed of in an area where it will not re-enter any water body. In addition, repairs and replacement of damaged silt fences and check dams will be addressed immediately.
- c) A minimum buffer zone of natural vegetation of 15 m from the high-water mark of waterbodies will be maintained around work areas where available space poses a constraint. If the available space allows for establishing wider buffer zones, then a 20 m buffer zone will be maintained between construction areas and watercourses and will be developed in consultation between the Project Manager and the Department of Environment and Conservation (DOEC). The limit of clearing will be flagged to delineate buffer zones near waterbodies.
- d) Where possible, fish habitat protection guidelines recommend the minimum width of the buffer zone between construction areas and all waterbodies will be calculated by the following formula:

$$\text{Buffer Width (m)} = 20 \text{ m} + 1.5 \times \text{slope (\%)}$$

- e) A minimum buffer zone of 25 m will be maintained around any archaeological site within which no construction activities will take place. Where available space poses constraints, this width may be reduced and supplemented by other protective measures.

Authority:	Operations Manager	Issue Date:	November 1, 2017
Custodian:	Environmental Coordinator	Revision Date:	March 13, 2018
Issuing Department:	Environmental	Document No.:	1.3

2.5 Environmental Concerns

Eroded material can increase siltation in waterbodies thereby decreasing suitable habitat for aquatic and animals. Erosion may lead to the loss of topsoil. Erosion prevention practices will be applied throughout all work areas on exposed or erodible materials.

Environmental Protection Procedures

General

Primary means of erosion control are avoidance of activities contributing to erosion. All areas of exposed erodible soils are to be stabilized by back-blading or grading to meet engineered slope requirements. Where erosion along exposed erodible slopes is a concern and a natural vegetation buffer of less than 15 m from the high-water mark exists between erodible areas and waterbodies, a silt fence, or more permanent check dam, will be constructed to control silt runoff.

Engineering requirements will vary depending on the locations of the silt fence and will take such factors into consideration as drainage/surface area of exposed soils and time of year the silt fences employed.

Specific erosion and sedimentation control measures have been designed for construction in Newfoundland to minimize the effects of construction activities on the environment. They include: site drainage ditching system, including culverts; and check dam traps which will provide both energy dissipation and siltation control. However, regardless of these protection measures, if an environmental inspection reveals that silt is entering a watercourse, further mitigative measures will be implemented.

In no case shall exposed soil be left un-stabilized for a period more than 30 days. Work conducted late in the season such that re-vegetation would be ineffective, will use straw mulch mixed into stabilized soil for over-winter protection.

Streams

All stream bank sections that contain loose or erodible materials are to be stabilized. No material is to be deposited within the watercourse. Sloping is to be accomplished by back-blading and the material removed is to be deposited above the high-water mark of any watercourse.

2.6 Water Supply

Water supply requirements during construction of the Mine/Mill are estimated to be 0.2 m³/hr and will be obtained from Pine Cove Pond; drinking water will be bottled. Water demand during operation is anticipated to be approximately 4 m³/hr to meet mill demands and general use by workers in buildings, equipment operation and fire demand; it will be recycled from the polishing pond and made up from Pine Cove Pond through insulated/trenched high-density polyethylene (HDPE) piping. Drinking water will be bottled.

Authority:	Operations Manager	Issue Date:	November 1, 2017
Custodian:	Environmental Coordinator	Revision Date:	March 13, 2018
Issuing Department:	Environmental	Document No.:	1.3

Environmental Concerns

Environmental concerns related to water supply include potential detrimental effects to the habitat (and populations) in and around Pine Cove Pond.

Environmental Protection Procedures

- a) The water intakes will have an appropriate screen to prevent damage to fish. Guidelines for the screening of water intakes are provided by DFO (1995).
- b) Reclaimed water from the polishing pond will be used to minimize fresh water demand from Pine Cove Pond.

2.7 Site Drainage

Surface water runoff will follow precipitation events.

Environmental Concerns

Environmental concerns related to surface water runoff include potential siltation of streams and erosion of earthworks.

Environmental Protection Procedures

The following measures will be implemented to minimize the potential impacts from surface water runoff:

- a) Surface water control facilities will be established prior to initiation of site development and pit development activities, including, as required:
 - Small settling/catchment basins;
 - diversion ditches and channels;
 - sumps and pumps; and
 - areas with potential for contamination (i.e., fuel storage areas).
- b) The settling pond will be constructed as a multiple cell system which can be easily expanded if required. The initial size of the system will be designed based on the anticipated surface water inflow to the pit and the groundwater inflow which will be determined by the planned hydrogeological study to be conducted prior to pit development. The settling pond will be constructed during initial stripping of the pit area.
- c) All site water that has the potential to be contaminated will be sampled and tested for the criteria listed in Schedule A of the *Environmental Control Water and Sewage Regulations, 2003* under the *Water Resources*

Authority:	Operations Manager	Issue Date:	November 1, 2017
Custodian:	Environmental Coordinator	Revision Date:	March 13, 2018
Issuing Department:	Environmental	Document No.:	1.3

Act, or any additional parameters contained in the C of A or permit before it is discharged to a waterbody. Any water that does not meet these criteria shall not be released to a waterbody as defined within the Act. A settling pond will be constructed to treat site drainage during the initial phase of the Project as described above. In the subsequent phase, site drainage will be directed for treatment to the tailings management area or the conditioning pond. These structures will be constructed and managed in a manner that will maintain capacity for storm drainage as well as normal operation.

2.8 Concrete Production/Placement

Environmental Concerns

Although cured concrete has little effect on water quality, fresh concrete and concrete products may raise the pH in receiving waters to potentially toxic levels (i.e., well above pH 9).

Environmental Protection Procedures

The following measures will be implemented to minimize the potential impacts from concrete production or placement.

- a) Mixing of cement to form concrete will take place at least 100 meters from any watercourse.
- b) Cement or fresh concrete shall not enter any watercourse or water body. Dumping of concrete or washing of tools and equipment in any body of water is prohibited.

If a concrete batch plant is to be used at the site, the measures set forth in the “Environmental Code of Practice for Concrete Batch Plant and Rock Washing Operations” prepared by the Department of Environment and Lands, Industrial Environmental Engineering Division, April 16, 1992 will be followed.

2.9 Trenching

The development of water infrastructure may require trenching for the burial of lines.

Environmental Concerns

Where excavation for the construction of water lines or any other infrastructure is undertaken, potential runoff of sediment-laden water could result in effects on freshwater fish habitat and water quality.

Authority:	Operations Manager	Issue Date:	November 1, 2017
Custodian:	Environmental Coordinator	Revision Date:	March 13, 2018
Issuing Department:	Environmental	Document No.:	1.3

Environmental Protection Procedures

The following measures will be implemented to minimize the potential impacts of trenching.

- a) The topsoil and excavated overburden and bedrock will be stored in separate stockpiles for later use during rehabilitation.
- b) Any material unsuitable for future rehabilitation will be disposed in a disposal area approved by the Project Manager.
- c) Dewatering of trenches will make use of measures to minimize and control the release of sediment laden water using filtration through erosion control devices, settling ponds, straw bales, geotextile or other devices.

2.10 Dewatering – Work Areas

Work areas, during site development, may require dewatering.

Environmental Concerns

The major concern associated with dewatering of construction sites is siltation and direct fish mortality and/or habitat destruction for freshwater species.

Environmental Protection Procedures

- a) The development of the pit for custom milling will involve pit dewatering and may require a settling pond to be located adjacent to the pit or to the east of the pit on the east side of Pine Cove Brook, as describe in Section 2.7 of this document.
- b) Filtration or other suitable measures, such as settling ponds, silt fences and dykes, will be provided to remove silt from, and reduce the turbidity of, water pumped from work areas before discharging.
- c) Where possible, clean water should be discharged to vegetated work areas to further reduce any potential effects on watercourses.
- d) The area of settling/catchment basins will be gauged to accommodate the anticipated volume of discharged water.
- e) Discharged water will be encouraged to follow natural surface drainage patterns.
- f) Proper precautionary measures will be employed to prevent the alteration, disruption and destruction of fish habitat.

Authority:	Operations Manager	Issue Date:	November 1, 2017
Custodian:	Environmental Coordinator	Revision Date:	March 13, 2018
Issuing Department:	Environmental	Document No.:	1.3

- g) Water pumped from excavations or work areas, or any runoff or effluent directed out of the project site must have silt removed by settling ponds, filtration or other suitable treatment before discharging to a body of water. Effluent discharge will comply with *Environmental Control Water and Sewage Regulations, 2003.*, any additional parameters contained in the C of A, and parameters defined in MMER.
- h) All site water including waste rock pile runoff, open pit water, tailings dam seepage, mill process water, tailings water and any other water that has the potential to be contaminated, will be sampled and tested for the criteria listed in Schedule A of the *Environmental Control Water and Sewage Regulations, 2003* under the *Water Resources Act*, any additional parameters contained in the C of A, and parameters defined in MMER before it is discharged to a waterbody. Any water that does not meet these criteria shall not be released to a waterbody as defined within the Act.

2.11 Excavation, Embankment and Grading

Environmental Concerns

The principal environmental concern associated with excavation, embankment and grading are the potential impacts on aquatic ecosystems and water quality due to runoff of sediment-laden water.

Environmental Protection Procedures

Work will be conducted in a manner that ensures the minimum amount of disturbance necessary. All works near waterbodies or watercourses will be performed in strict compliance with the required watercourse alteration approvals from the DOEC and DFO. Work will be conducted in a manner that controls potential sedimentation of watercourses and waterbodies in or adjacent to the work areas as outlined in the following procedures.

- a) Excavation, embankment and grading will be done only upon completion of grubbing and stripping. Where engineering requirements do not require grubbing and stripping (e.g., within the buffer zone of a stream crossing), filling will occur without any disturbance of the vegetation mat or the upper soil horizons.
- b) Excavation, embankment and grading near stream crossings will be done in a manner which ensures that erosion and sedimentation of watercourses and waterbodies is minimized and is done in strict compliance with the required watercourse alteration permits from the DOEC and DFO.
- c) A buffer zone of undisturbed vegetation will be maintained between construction areas and all watercourses (Section 2.4).

Authority:	Operations Manager	Issue Date:	November 1, 2017
Custodian:	Environmental Coordinator	Revision Date:	March 13, 2018
Issuing Department:	Environmental	Document No.:	1.3

2.12 Blasting on Land

Environmental Concerns

Blasting will be undertaken in association with mine development. The principal environmental concerns include the following:

- destruction of vegetation outside the open pit limits;
- noise disturbances to wildlife;
- disturbance of archaeological resources.

All blasting will be done in compliance with the appropriate permits' and approvals. All blasters will have a Blasters Safety Certificate from DOEC. All temporary magazines for explosive storage will have the appropriate approvals.

Environmental Protection Procedures

The handling, transportation, storage and use of explosives and all other hazardous materials will be conducted in compliance with all applicable laws, regulations, orders of the DOEC and the DNR-Mines, and the *Dangerous Goods Transportation Act* and the *Dangerous Goods Transportation Regulations, 1996*. The following measures will be implemented to minimize the impact of the use of explosives and blasting.

- a) Explosives will be used in a manner that will minimize damage or defacement of landscape features, trees and other surrounding objects by controlling through the best methods possible, the scatter of blasted material beyond the limits of activity. Outside of cleared areas, inadvertently damaged trees will be cut, removed and salvaged if merchantable.
- b) Blasting pattern and procedures will be used which minimize shock or instantaneous peak noise levels.
- c) Time delay blasting cycles will be used if necessary, to control the scatter of blasted material.
- d) Blasting will not occur near fuel storage facilities.
- d) The Blasters Safety Certificates from DOEC and the Temporary Magazine License (from Energy, Mines and Resources Canada) will be obtained prior to drilling and blasting.
- e) Use of explosives will be restricted to authorized personnel who have been trained in their use.
- f) There will be separate magazines on site, a magazine for explosives and a smaller cap magazine for dynamite blasting caps.
- g) The immediate area of the site will be surveyed within three hours prior to a blast and operations will be curtailed if sensitive animals (e.g., black bear, caribou, and moose) are observed within 500 m. Any individual animal sightings will be reported to the Project Manager.
- h) If blasting is necessary within the vicinity of an archaeological site, precautions must be taken to ensure that blasted material and shock waves do not disturb any part of the site. If necessary, protective covering should be applied to the site under the supervision of an archaeologist. Blasting shall not be undertaken in these areas without notifying the Project Manager.

Authority:	Operations Manager	Issue Date:	November 1, 2017
Custodian:	Environmental Coordinator	Revision Date:	March 13, 2018
Issuing Department:	Environmental	Document No.:	1.3

2.13 Blasting near Water

Environmental Concerns

Blasting may be undertaken in association with many of the work elements. Underwater blasting will not be undertaken as part of the project.

Blasting in or near waterbodies can severely affect organisms with swim bladders (fish) but may also affect a variety of aquatic animals including shellfish, mammals, otters, birds and waterfowl. Affects may be lethal, especially for the more sedentary species, but in many instances, disturbance will be sub-lethal, perhaps causing the subsequent avoidance of habitat. The introduction of silt and ammonia, into the water column is also a concern for freshwater water quality and related impacts on aquatic life.

Environmental Protection Procedures

To minimize the potential impacts of blasting operations upon the aquatic environment, Anaconda has made a commitment to a "zero" policy on blasting within a watercourse. In addition, blasting near a waterbody will only occur in situations where necessary and will comply with the following:

- a) The handling, transportation, storage, and use of explosives and all other hazardous materials will be conducted in compliance with all applicable laws, regulations and orders of the DOEC and the DNR-Mines.
- b) Explosives will be used in a manner that will minimize scatter of blasted material beyond the limits of the activity. Outside the cleared areas, inadvertently damaged trees will be cut, removed, and salvaged if merchantable. Damage to the organic mat outside of disturbed areas will be restored as required and as directed by the Project Manager.
- c) Blasting patterns and procedures which minimize shock or instantaneous peak noise levels will be used.
- d) Time delay blasting cycles will be used to control the scatter of blasted materials.
- e) Blasting will not occur near fuel storage facilities.
- f) Blasting will not occur within a waterbody, however if it is deemed necessary, it will be undertaken in compliance with the required water resources permits from the DOEC and approval by DFO (Area Habitat Biologist). Blasting in or near water will be conducted in accordance with DFO Guidelines (see: D.G. Wright and G.E. Hopky. 1998. Can. Tech. Rep. Fish. Aquat. Sci. 2107: iv + 34.p).
- g) The Blasters Safety Certificates (from the DOEC) and the Temporary Magazine License (from Energy, Mines and Resources Canada) will be obtained prior to drilling and blasting.
- h) Use of explosives will be restricted to authorized personnel who have been trained in their use.

Authority:	Operations Manager	Issue Date:	November 1, 2017
Custodian:	Environmental Coordinator	Revision Date:	March 13, 2018
Issuing Department:	Environmental	Document No.:	1.3

- i) There will be separate magazines on site, a magazine for explosives and a smaller cap magazine for dynamite blasting caps.
- j) Drilling and blasting activities will be done in a manner that ensures that the magnitude of explosions is limited to that which is necessary. A blasting plan will be reviewed with one of the local DFO fisheries officers, in advance of work near waterbodies. Anaconda's Project Manager will monitor the blast.
- k) Three hours prior to any blasting near waterbodies, a visual reconnaissance of the area will be undertaken to ensure that there are no waterfowl or aquatic furbearers near the blast site. Blasting will be delayed in such circumstances until they have been allowed to leave the area of their own accord. Under no circumstances will noise or other devices be used to harass or otherwise disturb these animals to encourage them to leave the area of the proposed blast.

2.14 Drilling – Exploration or Geotechnical

Environmental Concerns

The environmental concerns with exploration drilling are surface disturbances, disposal of drilling fluids and cuttings, generation of dust, noise and the potential impacts on terrestrial habitats, air quality, aquatic ecosystems and historic resources.

Environmental Protection Procedures

Potential drilling sites in sensitive areas, will be inspected by the Project Manager, whenever possible.

- a) Vegetation will be cleared following the procedures detailed in Section 2.2.
- b) Waste oil will be transported back to the Mill site for suitable disposal.
- c) Water applications will be used to control dust, where necessary and the source of water will be approved for use. The use of water for dust control or lubrication during drilling will be undertaken in a manner which ensures that runoff does not enter watercourses.
- d) Water used throughout the drilling process remains on the drill site. Water use is approved as part of the approval for exploration activities from the DNR-Mines. Every effort will be made to prevent turbid water from entering any watercourse.
- e) Cuttings from drill activities are not removed from the site. They will remain in the immediate location of drilling activities. Cuttings are not placed back down the hole.
- f) Drilling equipment will have muffled exhaust to minimize generated noise.
- g) Fuel will be stored, handled and transported according to Section 2.16.
- h) Garbage and solid waste will be removed from the drill site and deposited in an approved waste disposal area.
- i) Due to the nature of drilling activities (i.e., quick snaps, and couplings) oil drops and leaks sometimes occur and every attempt possible is made to clean up the area. All rigs are equipped with oil absorbent material in case of a leak or spill.

Authority:	Operations Manager	Issue Date:	November 1, 2017
Custodian:	Environmental Coordinator	Revision Date:	March 13, 2018
Issuing Department:	Environmental	Document No.:	1.3

- j) During the winter season, snow machines are used to transport drill materials, core and personnel to and from the drill sites.
- k) Drilling of water wells must be conducted in compliance with the Water Resources Act and Well Drilling Regulations, 2003.
- l) Abandoned exploration drill holes will be temporarily capped or indefinitely sealed with appropriate material depending on the timing to allow for any necessary downhole testing. When all test work on the hole has been completed, it will be permanently sealed.

2.15 Watercourse (Stream) Crossing

Environmental Concerns

The environmental concerns associated with stream crossings and culvert installations include direct disturbances to or mortality of fish, and potential loss of fish habitat resulting from sedimentation and removal of habitat and stream bank vegetation. An evaluation of soil erosion potential will be conducted at each of the stream crossings. This assessment of erosion risk will assist in the development of specific erosion stabilization methods and effective sedimentation control practices on a site-specific basis.

Environmental Protection Procedures

Stream crossings will be constructed in compliance with the required Permit for Culvert Installation from DOEC, Water Resources Management Division and any approvals required from DOEC and DFO. Anaconda recognizes that DFO does not routinely issue permits for instream work between September 15 and June 1. Anaconda will therefore consult with DFO to develop mitigation strategies to minimize the impact of instream work during sensitive periods.

The following measures will be implemented to minimize the potential impacts of stream crossings:

- a) Between September 1 and June 15, stream crossing construction activities will be undertaken under the direct supervision of the Project Manager.
- b) Work will be performed in such a way as to ensure that deleterious substances including, but not limited to, materials such as sediment, fuel and oil do not enter watercourses and waterbodies.
- c) A minimum buffer of undisturbed natural vegetation must be left between the access road and the bank of any watercourse that it parallels. Where possible, the buffer width will be determined through the formula:

$$\text{Buffer width (m)} = 20 \text{ m} + 1.5 \times \text{slope (\%)}$$

- d) In those locations where culverts are required, application will be made to DOEC and DFO. The culverts used will be sized to handle the 1-in-25-year return period flood and will be constructed in accordance with the Environmental Guidelines for Culverts from the DOEC, Water Resources Division. The following measures will also be implemented:

Authority:	Operations Manager	Issue Date:	November 1, 2017
Custodian:	Environmental Coordinator	Revision Date:	March 13, 2018
Issuing Department:	Environmental	Document No.:	1.3

- i) install culvert(s) in accordance with good engineering and environmental practices;
- ii) unless otherwise indicated, all work should take place in dry conditions, either using cofferdams or by diverting the stream.
 - installation of cylindrical culverts shall be counter sunk only where necessary to protect fish habitat such that the culvert bottom is one-third the diameter below the streambed in the case of culverts less than 750 mm outside the diameter; for culverts greater than 750 mm outside diameter, the culvert bottom shall be installed a minimum of 300 mm below the streambed;
 - in multiple (gang) culvert installations, install one culvert at an elevation lower than the others;
- iii) ensure that the natural low flow regime of the watercourse is not altered;
- iv) a culvert will not be installed before site specific information such as localized stream gradient, fish habitat type and species present have been evaluated. Culverts are to be installed using the guidelines provided in Gosse et al. (1998).
- v) riprap outlets and inlets to prevent erosion of fill slopes;
- vi) use culverts of sufficient length to extend a short distance beyond the toe of the fill material;
- vii) use backfilling material that is of a texture that shall support the culvert and limit seepage and subsequent washing out;
- viii) align culverts such that the original direction of stream flow is not significantly altered;
- ix) remove fill and construction debris from the culvert area to a location above the peak flow level to prevent its entry into the stream;
- x) confine construction activity to the immediate area of the culvert;
- xi) fill material shall not be removed from streambeds or banks; except when installing a culvert when removal of material is necessary to ensure a flat foundation;
- xii) minimize and restrict the use of heavy equipment in and near watercourses; where possible, an excavator will be used from shore rather than a bulldozer in the watercourse. Where it is absolutely necessary to do so, instream work will be performed by rubber-tired vehicles only and will only be done in compliance with approvals from DOEC and DFO, respectively;
- xiii) as required, cofferdams of non-erodible material shall be used to separate work areas from the watercourse when excavating for culverts and footings; and

Authority:	Operations Manager	Issue Date:	November 1, 2017
Custodian:	Environmental Coordinator	Revision Date:	March 13, 2018
Issuing Department:	Environmental	Document No.:	1.3

xiv) cofferdams shall be removed upon completion of construction and the streambed returned as closely as possible to its original condition.

- e) When fording any watercourse, the Environmental Guidelines for Fording from DOEC, Water Resources Division 1992 will be applied in conjunction with the following:
- i) areas of spawning habitat will be avoided;
 - ii) crossings shall be restricted to a single location and crossings made at right angles to the watercourse;
 - iii) equipment activity within the watercourse shall be minimized by limiting the number of crossings;
 - iv) ensure that all equipment is mechanically sound to avoid leaks of oil, gasoline and hydraulic fluids;
 - v) ensure that no servicing or washing of heavy equipment occurs adjacent to watercourses; temporary fuelling, servicing or washing of equipment in areas other than the main fuel storage site shall not be allowed within 30 m of a watercourse except within a refuelling site approved by Anaconda, where conditions allow for containment of accidentally spilled fuels; remove from the work area and properly dispose of all waste oil, filters, containers or other such debris in an approved waste disposal site;
 - vi) stabilize the entire fording area using vegetation mats, corduroy roads or coarse material (125 mm diameter or greater) when such material is available from a reasonably close location within the right-of-way, and the ford area is not natural bedrock, or is easily disturbed by fording; when the substrate of the ford area is not subject to easy disturbance by fording, or coarse material is not easily available within the right-of-way, fording under existing substrate conditions may occur under the direction of the Project Manager;
 - vii) ensure that fording activities shall not decrease the depth of the watercourses to less than 20 cm; where the existing depth is less than 20 cm, that depth shall be maintained;
 - viii) ensure that fording activities are halted during high flow periods;
 - ix) stabilize all bank sections which contain loose or erodible materials; if banks must be sloped for stabilization, no material shall be deposited within the watercourse; sloping shall be accomplished by back-blading and the material removed shall be deposited above the high-water mark of the watercourse;
 - x) all fording activities will comply with the required approvals from the DOEC and DFO;
 - xi) the flow of water must be diverted around the work area during the installation of a culvert to ensure dry conditions are prevalent for construction activities; and
 - xii) culverts must be marked to indicate their position under the snow.

Authority:	Operations Manager	Issue Date:	November 1, 2017
Custodian:	Environmental Coordinator	Revision Date:	March 13, 2018
Issuing Department:	Environmental	Document No.:	1.3

2.16 Storage, Handling and Transfer of Fuel and Other Hazardous Material

Environmental Concerns

The major concern regarding the use of hazardous substances is their uncontrolled release to the environment through spillage and subsequent adverse effects on terrestrial, aquatic and marine habitat and species, soil, groundwater quality and human health and safety. The mine/mill will use the following hazardous materials: gasoline, diesel, sodium cyanide, zinc powder, sodium metabisulphite, lime, flotation reagents (sodium xanthate and MIBC) and copper sulphate.

Burnt or hydrated lime will be used for pH control in the leaching circuit to guarantee a pH of 10 or higher. Sodium cyanide will be used as a lixiviant to leach the gold from the solution. Detoxification of cyanided concentrate tailings will be completed with sodium metabisulphite and compressed (diffused) air used as an oxidant with a copper sulfate catalyst. The reagent storage area will have an impermeable floor and raised lip to contain a potential spill or leakage. Fuel for equipment will be delivered with the use of mobile fuel equipment.

Environmental Protection Procedures

The Point Rousse Project site will implement high standards for the storage and handling of fuel. Fuel and other materials will be brought to the site by vehicle. Drummed fuel will be stored in an area at the Mill site. The area will have an impervious fabric liner and will be dyked suitably to collect and control any spillage. Bulk fuel storage will be in self-contained, dyked tanks. Gasoline will be held in a tank at the Mill site.

When the final site layout and plans are determined, a list and map will depict all locations of fuel storage and non-portable transfer lines.

The following procedures will apply to the use of fuel and other hazardous materials:

- a) The Workplace Hazardous Materials Information System (WHMIS) Regulations, 1996 under the *Occupational Health and Safety Act* will apply to all handling and storage of hazardous materials, and thus all relevant Material Safety Data Sheets (MSDS) will be readily available and maintained current.
- b) During road construction/upgrade, as much as practical, fuelling of the construction equipment will be carried out in a central location, in other words the construction equipment will travel short distances to the central fuel location/locations depending on the number of sections of road under construction. The mobile fuel vehicle will contain adequate fuel spill equipment in the event of a spill. All construction vehicles and construction equipment shall be required to carry emergency spill kits. The contractor's work force shall be trained prior to arrival on site, in the procedures to be undertaken in the event of a fuel spill. These procedures will become part of the contractor's submittal requirements after award of contract. At that time, a complete detailed list of spill kits will be available. The Construction Manager will keep a list of all Spill Kits available in each vehicle.
- c) All necessary precautions will be taken to prevent and minimize the spillage, misplacement or loss of fuels and other hazardous materials.

Authority:	Operations Manager	Issue Date:	November 1, 2017
Custodian:	Environmental Coordinator	Revision Date:	March 13, 2018
Issuing Department:	Environmental	Document No.:	1.3

- d) Before installing fuel storage tanks, the necessary approvals in compliance with *The Storage and Handling of Gasoline and Associated Products, 2003* under the *Environmental Protection Act* will be obtained from the Newfoundland and Labrador Department of Government Services. Verification of the storage tank approval will be retained for Anaconda.
- e) Fuels and other hazardous materials will be handled only by persons who are trained and qualified in handling these materials in accordance with the manufacturer's instructions and government laws and regulations. Operators will be present for the duration of a refuelling operation.
- f) In the event of any spill on land regardless of size that may enter a waterbody frequented by fish must be reported immediately to the spill line (709) 772-2083 or (800) 563-9089 as required by the *Fisheries Act*.
- g) In the event of a spill or leak from a vehicle, pipeline or storage tank system, the operator of the vehicle, pipeline or storage tank system shall immediately:
 - ii) notify the DOEC; and
 - iii) take those steps that are necessary to abate the discharge, clean the area affected and restore the environment to the satisfaction of the DOEC. Assessment and treatment of affected areas will be completed in a manner compatible with the *Guidance Document for the Management of Impacted Sites* (DOEC 2004).
- h) Oils, grease, gasoline, diesel or other fuels will be stored at least 100 m from any surface water.
- i) Handling and fuelling procedures will comply with *The Storage and Handling of Gasoline and Associated Products, 2003* and any additional requirements put forth by the DOEC to limit potential contamination of soil or water.
- j) Any above-ground fuel container except for those exempted under *The Storage and Handling of Gasoline and Associated Products, 2003*, will be positioned over an impervious mat and will be surrounded by an impervious dyke of sufficient height (minimum height 0.6 m) to contain:
 - i) where a dyked area contains only one storage tank, the dyked area shall retain not less than 110% of the capacity of the tank; and
 - ii) where a dyked area contains more than one storage tank, the dyked area shall retain not less than 110% of the capacity of the largest tank or 100% of the capacity of the largest tank plus 10% of the aggregate capacity of all the other tanks whichever is greater. Otherwise, approved self-dyked storage tanks will be used where required.
- k) Any dykes of earthwork construction will have a flat top not less than 0.6 m wide and be constructed and maintained to be liquid tight to a permeability of 25 L/m³/day. The distance between a storage tank shell and the centre line of a dyke will be at least one-half the tank height.

Authority:	Operations Manager	Issue Date:	November 1, 2017
Custodian:	Environmental Coordinator	Revision Date:	March 13, 2018
Issuing Department:	Environmental	Document No.:	1.3

- l) Storage tanks will be equipped with spill kits and additional spill kits will be available at a designated central storage location. All fuel transfer vehicles will be equipped with spill kits. All fuel handling personnel and other designated personnel will be trained in the use of spill kits and all training will be documented.
- m) Inventory of spill kits will be checked and verified to include at the minimum:
- 2 45-gallon polyethylene drums complete with covers and lever locks, printed 'SPILL KIT'
 - 2 bags 44 litres each – *Oclansorb
 - 100 Hi Point absorbent pads (3/8" x 17" x 19")
 - 2 Spark resistant poly-shovels
 - 10 4-mil yellow heavy-duty disposal bags (30"x48")
 - 10 4" x 4" Sorb Sox
 - 10 4" x 8" Sorb Sox
 - 2 Pairs chemical resistant gloves
- n) Fuel storage areas and non-portable transfer lines will be clearly marked or barricaded to ensure that they are not damaged by moving vehicles. The markers will be visible under all weather conditions. Barriers will be constructed in compliance with the *Storage and Handling of Gasoline and Associated Product Regulations, 2003*.
- o) Waste oils, lubricants, and other used oil will be disposed of under contract with a licensed used oil collector in accordance with the *Used Oil Control Regulation, 2002* under the *Environmental Protection Act*. If required by the Minister, a certificate of approval for the collection, storage and transportation of used oil will be obtained.
- p) All storage tank systems will be inspected on a regular basis as per *The Storage and Handling of Gasoline and Associated Products, 2003*. This involves, but is not limited to, gauging or dipping and the keeping of reconciliation records for the duration of the program.
- q) Contracted fuel suppliers will, before transporting or positioning fuel at the exploration site, have on file at Anaconda a copy of their fuel and hazardous material spills contingency plan which is required under *The Storage and Handling of Gasoline and Associated Products, 2003* and which is acceptable to Anaconda. The fuel and hazardous material spills contingency plan for Anaconda is provided in Section 3.1.
- r) Smoking will be prohibited within 10 m of a fuel storage area.
- s) Temporary fuelling or servicing of mobile equipment in areas other than the main fuel storage site will not be allowed within 100 m of a watercourse.
- t) Anaconda will, within thirty (30) days of known decommissioning of a storage tank system, empty the system of all products, remove the tank and associated piping from the ground, remove any contaminated soil, clean the area and restore the site.

Authority:	Operations Manager	Issue Date:	November 1, 2017
Custodian:	Environmental Coordinator	Revision Date:	March 13, 2018
Issuing Department:	Environmental	Document No.:	1.3

- u) Any soil contaminated by small leaks of oil or grease from equipment will be disposed of in accordance with the *Waste Management Regulations, 2003* under the *Environmental Protection Act* and the *Used Oil Control Regulations*.
- v) A copy of the Contingency Plan for Fuel and Hazardous Material Spills (Section 3.1) will be present at storage facilities and during transfer of fuel. In case of a spill, the outlined procedures will be followed.
- w) Bulk fuel storage facilities will be dipped on a weekly basis to accurately gauge fuel consumption. These consumption rates will allow for visually undetectable sources of contamination to be identified and corrected.
- x) Hazardous (HAZMAT) waste produced on the site will be stored in a designated storage built on a concrete slab. The slab will be designed to contain all spills from stored HAZMAT. HAZMAT will include mainly used greases, used oils, used solvents and used batteries. A list of the material stored will be maintained at the entrance of the storage. The batteries will be contained in a steel container to avoid any contacts between acid and a non-compatible HAZMAT. The storage will be kept locked. Contingency plans will be written during the construction phase and will detail response procedures in case of a fire or a spill.
- y) To reduce waste and prevent pollution, Anaconda will endeavour to return all reagent packaging to the manufacturer for recycling.

2.17 Solid Waste Disposal

Environmental Concerns

Solid waste (e.g., domestic waste, paper, cardboard, wood), if not properly controlled and disposed of, will be unsightly, may cause human safety and health concerns, and could result in conflict with wildlife. Solid waste will be disposed of at the local municipal landfill site.

Environmental Protection Procedures

- a) Solid waste produced by site personnel and operations will be collected and disposed of at a local Baie Verte municipal dumpsite.
- b) Waste accumulated on site prior to disposal will be confined in "bear-resistant" containers so that it does not pose an environmental or health hazard or cause conflict with wildlife.
- c) Sewage waste will be disposed of in an approved septic tank-tile field system.
- d) No other waste material will be deposited on-site.

2.18 Sewage Disposal

Environmental Concerns

Authority:	Operations Manager	Issue Date:	November 1, 2017
Custodian:	Environmental Coordinator	Revision Date:	March 13, 2018
Issuing Department:	Environmental	Document No.:	1.3

The release of untreated sewage is a concern to human health, drinking water quality, and freshwater and marine ecosystems.

Environmental Protection Procedures

- a) Portable toilets will be used at site during the Custom Milling phase and construction phase of the mine/mill. Sewage will be stored in holding tanks and disposed off site in an approved manner.
- b) A sewage treatment system will be installed for the operations phase. The sewage disposal system will comply with the Newfoundland and Labrador Department of Health guidelines, the *Lands Act*, Waste Management Regulations, 2003 under the *Environmental Protection Act* and the *Environmental Control Water and Sewage Regulations, 2003* under the *Environmental Protection Act*.
- c) Development of sewage facilities will proceed in consultation with the relevant regulatory agencies for a temporary or permanent sewage collection system and a Certificate of Environmental Approval to Establish or Alter a Waste Management System will be obtained from the Newfoundland and Labrador Department of Government Services and DOEC.
- d) The location of the sewage tile field will be clearly marked, and vehicular traffic will not be permitted to operate within this defined boundary.
- e) Chlorine is not considered an option for sewage waste disinfection.

2.19 Mine Water/Waste Water Treatment

Environmental Concerns

The principle concerns associated with mine water and waste treatment are the potential impacts on freshwater ecosystems and water quality.

Environmental Protection Procedures

Measures undertaken to minimize impact on aquatic habitat and resources are as follows:

- a) During the custom milling phase, pit water will be directed to a settling pond located adjacent to the pit or on the east side of Pine Cove Brook near the pit.
- b) Wastewater from the open pit will be directed to the tailings area or to the conditioning pond.
- c) If waste rock is determined to be potentially acid generating (PAG), it will be segregated from inert waste rock. PAG waste rock will be identified using static, kinetic and field tests during operation. PAG waste rock will be placed on a low permeability pad where any runoff from the pile will be collected for pumping to the tailings area.

Authority:	Operations Manager	Issue Date:	November 1, 2017
Custodian:	Environmental Coordinator	Revision Date:	March 13, 2018
Issuing Department:	Environmental	Document No.:	1.3

- d) To minimize total water use, water will be reclaimed from the polishing pond to be reused as process water in the mill. Reclaimed water from the polishing pond will be used to minimize fresh water demand from Pine Cove Pond.
- e) Mill complex area drainage will be directed to the tailings area.
- f) Tailings water (supernatant) from the tailings area will be discharged to the conditioning pond, where it will be treated, if and as required (e.g., pH adjustment using lime and retention/storage).
- g) Water including pit water, mill process water, tailings water and any other water that has the potential to be contaminated, will be directed to the tailings area. Tailings water will be discharged to the conditioning pond, and then discharged to the polishing pond. It will be treated, if required. The water released from the polishing pond will be sampled and tested for the criteria listed in Schedule A of the *Environmental Control Water and Sewage Regulations, 2003* under the *Water Resources Act*, any additional parameters contained in the C of A, and parameters defined in MMER before it is discharged to a waterbody. Any water that does not meet these criteria shall not be released to a waterbody as defined within the Act.
- h) The relevant discharge criteria from the *Environmental Control Water and Sewage Regulations, 2003* are listed in Schedule A below:

Authority:	Operations Manager	Issue Date:	November 1, 2017
Custodian:	Environmental Coordinator	Revision Date:	March 13, 2018
Issuing Department:	Environmental	Document No.:	1.3

Schedule A (from *Environmental Control Water and Sewage Regulations, 2003*)

Column 1 Constituents	Column 2 Maximum Content (in milligrams per litre unless noted)
B.O.D.	20
Coliform - faecal	1000/100 mL
Coliform - total	5000/100 mL
Solids (dissolved)	1000 (see note)
Solids (suspended)	30 (see note)
Oils (Ether extract)	15
Floating debris, oils and grease	None to be visible
Arsenic	0.5
Barium	5.0
Boron	5.0
Cadmium	0.05
Chlorine	1.0
Chromium (hexavalent)	0.05
Chromium (trivalent)	1.0
Copper	0.3
Cyanide	0.025
Iron (total)	10
Lead	0.2
Mercury	.005
Nickel	0.5
Nitrates	10
Nitrogen (ammoniacal)	2.0
Phenol	0.1
Phosphates (total as P ₂ O ₅)	1.0
Phosphorus (elemental)	0.0005
Selenium	0.01
Sulfides	0.5
Silver	0.05
Zinc	0.5
<p>Note: If water is being abstracted from a water course. Used, treated and subsequently returned to the same water course, these solids data mean that the effluent should not contain more than 100 or 30 mg/L more than was in the water originally abstracted</p>	

Authority:	Operations Manager	Issue Date:	November 1, 2017
Custodian:	Environmental Coordinator	Revision Date:	March 13, 2018
Issuing Department:	Environmental	Document No.:	1.3

2.20 Dust Control

Environmental Concerns

The environmental concerns associated with dust include human health effects and potential impacts on aquatic ecosystems and vegetation.

Environmental Protection Procedures

- a) Dust from construction activities will be controlled by using water.
- b) Waste oil will not be used for dust control, but other agents such as calcium chloride may be used with the approval of regulatory agencies.

2.21 Noise Control

Environmental Concerns

A variety of noises associated with heavy construction activity can cause negative effects on wildlife resources in terms of their distribution and abundance. Noises associated with blasting and heavy equipment use are temporary in nature and noises associated with drilling are considered long term, but localized.

Environmental Protection Procedures

Measures will be implemented wherever possible to minimize potential impacts arising from a variety of noise sources.

- a) Adherence to all permits, and approvals.
- b) Blasting plans will be developed prior to blasting.
- c) All vehicles and generators will have exhaust systems regularly inspected and mufflers will be operating properly.

2.22 Equipment Use and Maintenance

Environmental Concerns

A variety of mobile heavy equipment will be used throughout the project. Environmental concerns related to equipment use and maintenance include accidental spills and chronic leaks that may contaminate on-site waterbodies.

Environmental Protection Procedures

Authority:	Operations Manager	Issue Date:	November 1, 2017
Custodian:	Environmental Coordinator	Revision Date:	March 13, 2018
Issuing Department:	Environmental	Document No.:	1.3

The following measures will be implemented to minimize the potential impact of equipment use and maintenance.

- a) All pumps will have drip pans placed beneath them.
- b) Routine inspections will be conducted on all hoses and connections on equipment.
- c) The only maintenance and repairs performed on-site will be minor (e.g., lubrication) and only performed on non-mobile equipment such as drilling equipment; all major repairs will be conducted in the shop area.
- d) All major equipment maintenance will be conducted in the shop area.
- e) The designated equipment storage areas will be located a minimum 50 m from waterbodies.
- f) All fuelling activities will be conducted at the fuel depot.
- g) All leaks will be repaired, and a report provided immediately to the Project Manager.
- h) Refer to Section 2.16 for explicit environmental protection procedures pertaining to the handling, storage and transportation of all fuels and other hazardous materials.
- i) If a fuel or hazardous materials spill occurs, respond as per the contingency plan provided in Section 3.1.
- j) In addition to spill kits located at fuel storage tanks additional spill kits will be located at designated central storage location(s). Personnel who deal with fuelling, fuel transfer and equipment use, and maintenance will be trained in the use of the kits.

2.23 Pumps and Generators

Environmental Concerns

A variety of water pumps, hoses and generators are in frequent use in many areas of mine sites. Environmental concerns are associated with any accidental spills or chronic leaks contaminating waterbodies.

Environmental Protection Procedure

- a) Fuel must not be stored near generators or located adjacent to waterbodies.
- b) Drip pans should be placed underneath pumps and generators located near waterbodies.
- c) Hoses and connections on equipment located near waterbodies should be inspected routinely for leaks and drips.
- d) All leaks should be reported immediately to the Project Manager.

Authority:	Operations Manager	Issue Date:	November 1, 2017
Custodian:	Environmental Coordinator	Revision Date:	March 13, 2018
Issuing Department:	Environmental	Document No.:	1.3

- e) In addition to spill kits located at fuel storage tanks additional spill kits will be located at designated central storage location(s). Personnel who deal with fuelling, fuel transfer and pumps and generators will be trained in the use of the kits.

2.24 Vehicle Traffic, including ATV and Snowmobile Traffic

Environmental Concerns

A source of physical disturbances to the environment during exploration and mine operations is a result of vehicle movements within the project area. Some activities may be supported using ATVs and tracked vehicles that could result in ground disturbance.

Environmental Protection Procedures

- a) The use of ATVs will be restricted to designated trails to minimize ground disturbance. ATV use will comply with the Motorized Snow Mobile and All-Terrain Vehicle Regulations, 1996 under the *Motorized Snow Mobile and All-Terrain Vehicle Act* and the Environmental Guidelines for Stream Crossings by All-Terrain Vehicles issued by Water Resources Management Division.
- b) During winter when the ground is covered with snow, snow machines will be used for equipment movement and supply. Where possible, snow machines will use established pathways, also minimizing disturbances to vegetation.
- c) The use of heavy equipment in and near watercourses will be minimized and restricted; where possible an excavator will be used from shore rather than a bulldozer in the watercourse. Where it is necessary to do so, instream work will be performed by rubber-tired vehicles only, and will only be done in compliance with permits and approvals from DOEC and DFO, respectively (Section 2.16).

2.25 Tailings Dam Inspection

Environmental Protection Procedures

- a) The tailings dam will be designed and constructed and maintained in accordance with the Canadian Dam Association Guidelines.
- b) Anaconda will develop an operation, maintenance and surveillance manual for the tailings dams per the Mining Association of Canada guidelines. This will be completed by the personnel responsible for the operation and inspection of dams prior to the start of operation of the tailings area
- c) If a failure should occur, mitigated measures would reduce the extent of solids movement downstream as well as recover displaced solids. Mitigation measures would include additional dam development, stream diversion, and removal of displaced solids and subsequent re-confinement.
- d) As a contingency measure, a seepage collection ditch and pond will be provided along the downstream toe of the dam to collect the seepage through the dam.

Authority:	Operations Manager	Issue Date:	November 1, 2017
Custodian:	Environmental Coordinator	Revision Date:	March 13, 2018
Issuing Department:	Environmental	Document No.:	1.3

- e) The planned tailings area dam has been designed to have an overflow spillway to protect the integrity of the structure during periods of extreme flooding. Should a failure occur, corrective actions would be employed to reduce the extent of solids migration downstream. Response actions will include additional dam development, stream diversion, and the removal of displaced solids and subsequent re-confinement.
- f) An emergency spillway will be provided at the northern abutment of the dam, such that the spillway discharge will report to the conditioning pond.
- g) A program of systematic performance assessment by means of periodic inspections and instrument monitoring will be provided to ensure safe behaviour of the dams and appurtenant structures in accordance with the design.
- h) Several inspection activities will be carried out to ensure safety of the dam and the appurtenant structures, including dam surveillance and dam safety inspections. Dam inspections will be conducted twice a year by project personnel and once a year by an independent consultant.
- i) The seepage flow through the dam and foundation will be minimized by design provisions consisting of an HDPE membrane over sand.
- j) Groundwater monitoring wells, if required, will be installed downstream of the dam and will be monitored on a regular basis to detect any near surface changes in groundwater quality.
- k) The permits for the tailings dams may also include specific requirements for surface and groundwater monitoring, including the provision for real time water quality monitoring.

2.26 Hazardous Waste Disposal

Environmental Concerns

The primary concern with disposing of hazardous substances is that there may be an uncontrolled release to the environment through leakage or accidental spillage, and subsequent adverse effects on terrestrial and aquatic habitat and species, soil, groundwater quality, and human health and safety.

Authority:	Operations Manager	Issue Date:	November 1, 2017
Custodian:	Environmental Coordinator	Revision Date:	March 13, 2018
Issuing Department:	Environmental	Document No.:	1.3

Environmental Protection Procedures

- a) All hazardous waste will be handled according to the provincial *Environmental Protection Act*. Waste classified as "hazardous" or "special" that can not be disposed of in regular landfill sites will be sent for disposal at a licensed hazardous waste management company.
- b) All necessary precautions will be taken to prevent and reduce the spillage, misplacement or loss of fuels and other hazardous materials. In the event of a spill on-land or in the freshwater environment, refer to the Anaconda Contingency Plan (in prep.).
- c) A copy of the Anaconda Contingency Plan will be present at hazardous material storage sites and fuel transfer locations.
- d) Hazardous waste materials will only be handled by persons who are qualified and trained in handling these materials as stipulated in government laws and regulations.
- e) Waste accumulated on site prior to disposal will be confined, so that it does not pose an environmental or health hazard.
- f) Waste material will not be disposed of on-site or in a body of water.
- g) Burning of waste is not permitted.
- h) Where hazardous waste materials are to be stored outdoors, a designated area will be established, graded and fitted with an impermeable membrane covered with local soil and surrounded by an earth berm.
- i) Waste oils, lubricants, and other used oil will be retained in a tank or closed container and disposed of in accordance with the *Used Oil Control Regulations*.
- j) Any soil contaminated by small leaks of oil or grease from equipment will be disposed of according to the *Environmental Protection Act*.
- k) All hazardous wastes generated, because of the treatment alternatives, will be handled according to the procedures for handling fuel and hazardous materials (Section 2.16).

2.27 Marshalling and Storage Areas

Environmental Concerns

Areas will be required for storing and maintaining equipment and supplies through the operation phase of Pine Cove Gold Mine. Erosion and run-off of sediment into nearby water bodies will be prevented.

Authority:	Operations Manager	Issue Date:	November 1, 2017
Custodian:	Environmental Coordinator	Revision Date:	March 13, 2018
Issuing Department:	Environmental	Document No.:	1.3

Environmental Protection Procedures

- a) Any new marshalling, maintenance or storage areas required for the Project will only be established within the Project property.
- b) Establishing any new marshalling or storage areas will follow the procedures for vegetation clearing (Section 2.3), grubbing and debris disposal (Section 2.3), and erosion prevention (Section 2.5).
- c) External storage areas will be placed on level terrain and kept free of ponding or run-off.
- d) Drainage from areas of exposed fill will be controlled by grade or ditching and directing run-off away from water bodies.
- e) Marshalling and storage areas not required during operations will be rehabilitated.

Authority:	Operations Manager	Issue Date:	November 1, 2017
Custodian:	Environmental Coordinator	Revision Date:	March 13, 2018
Issuing Department:	Environmental	Document No.:	1.3

3 Contingency Plan

Note: Contingency plans to deal with accidents and unplanned situations have been developed and will be modified as required throughout the project.

In reaching decisions on containment and clean-up procedures, the objectives of these contingency plans are to minimize the following:

- danger to persons;
- pollution to watercourses;
- area affected by the spill or fire;
- degree of disturbance to the area and watercourses during clean-up; and,
- degree of disturbance to wildlife.

Notwithstanding contingency plans, Anaconda will adopt a policy to implement preventative measures as its first line of defense against the possibility of accidents.

Contingency plans have been developed for the following accidental and unplanned situations.

- 3.1 Fuel and Hazardous
- 3.2 Wildlife Encounters
- 3.3 Discovery of Historic Resources
- 3.4 Forest Fires
- 3.5 Tailings Dam Failure
- 3.6 First Aid

As noted in Section 1.3, additional contingency plans will be detailed to address:

- Procedure in case of an Environmental Incident (general communication line)
- Procedure in case of fire on the surface
- Procedure in case of spill from the tailings and process water lines
- Procedure in case of a mill reactive product spill
- Procedure in case of a spill from a truck concentrate on site.

These plans will be developed in information and planning that will be completed prior to operations.

Authority:	Operations Manager	Issue Date:	November 1, 2017
Custodian:	Environmental Coordinator	Revision Date:	March 13, 2018
Issuing Department:	Environmental	Document No.:	1.3

3.1 Fuel and Hazardous Material Spills

Environmental Protection Procedures

In case of a fuel or hazardous material spill, the following procedures will apply.

- a) The individual who discovers the leak or spill will make a reasonable attempt to immediately stop the leakage and contain the flow. Spill kits are located at fuel storage tanks and at designated central storage location(s)
- b) Spill location, type of fuel or hazardous material, volume and terrain condition at the spill site will be determined and reported immediately to the Project Manager, who will report it immediately to Environment Canada (Item C).
- c) In the event of any spill on land regardless of size that may enter a waterbody frequented by fish must be reported immediately to the spill line (709) 772-2083 or (800)563-9089 as required by the *Fisheries Act*. Required pertinent information includes:
 - i) name of reporter and phone number;
 - ii) time of spill or leak;
 - iii) time of detection of spill or leak;
 - iv) type of product spilled or leaked;
 - v) location of spill or leak;
 - vi) source of spill or leak;
 - vii) type of accident-collision, rupture, overflow, other;
 - viii) owner of product and phone number;
 - ix) if the spill is leaking or still occurring;
 - x) if the spill or leaked product is contained, and if not, where it is flowing;
 - xi) wind velocity and direction
 - xii) temperature
 - xiii) proximity to waterbodies, water intakes, and facilities; and,
 - xiv) snow cover and depth, terrain and soil conditions.
- d) The Project Manager will act as the On-Scene Commander for the purposes of cleaning up a fuel or hazardous materials spill. The Project Manager is familiar with spill clean-up procedures and mobilization procedures of the clean-up equipment. The Project Manager has full authority to take necessary and appropriate action without unnecessary delay.

The overall responsibility of coordinating a clean-up and maintaining this contingency plan current and up-to-date will be the Environmental Coordinators responsibility.

Staff will be trained on the procedures to follow just in case of hydrocarbon spills as well as information related to general communication line. Anaconda will provide personnel and responsibilities list before the start of construction.

A complete list of spill response equipment will be generated and distributed on-site before the start of construction.

Authority:	Operations Manager	Issue Date:	November 1, 2017
Custodian:	Environmental Coordinator	Revision Date:	March 13, 2018
Issuing Department:	Environmental	Document No.:	1.3

- e) In reaching decisions on containment and clean-up procedures, the following criteria will be applied:
- i) minimize danger to persons;
 - ii) protect water supplies;
 - iii) minimize pollution of watercourses
 - iv) minimize are affected by spill; and
 - v) minimize the degree of disturbance to the area
- f) The Project Manager will act in consultation with the regulating authorities to:
- i) assess site conditions and environmental impacts of various cleanup procedures;
 - ii) assess potential for fuel recovery versus burning;
 - iii) deploy on-site staff to mobilize pumps and empty 215-L drums or other appropriate storage containers to the spill site;
 - iv) deploy on-site staff to build containment dykes and commence pumping containment into drums;
 - v) apply absorbent as necessary;
 - vi) dispose of all containment debris, cleaning materials and absorbent by burning, if appropriate or by placing it in an approved land fill site; and
 - vii) take all necessary precautions to ensure that the incident does not recur.
- g) The Project Manager will be responsible for the preparation of a written report which will be sent (as soon as possible and no later than 30 days after the spill) to Anaconda; and, from there to:
- Director, Pollution Prevention Division
Department of Municipal Affairs and Environment
P.O. Box 8700
St, John's, NL
A1B 4J6
Tel: (709) 643-6114 Fax: (709) 292-4528

and

Mr. Neil Codner
Environment and Climate Change Canada
6 Bruce Street
Mount Pearl, NL
A1N 4T3
(709) 772-4285 (bus)

Authority:	Operations Manager	Issue Date:	November 1, 2017
Custodian:	Environmental Coordinator	Revision Date:	March 13, 2018
Issuing Department:	Environmental	Document No.:	1.3

3.2 Wildlife Encounters

Environmental Protection Procedures

Prevention

As a protection measure, hunting, trapping or fishing by project personnel is not permitted at the site.

The Project Manager is responsible to see that the following procedures relating to storage and waste disposal are implemented.

- a) Site and working areas will be kept clean of food scraps and garbage.
- b) Waste will be collected for disposal in bear-resistant containers. Waste will be transferred to the local landfill located in Baie Verte routinely as needed.

Response Actions

All project personnel will abide by the following rules in case of wildlife encounters:

- a) No attempt will be made by any person at the project site to chase, catch, divert, follow or otherwise harass wildlife by vehicle or on foot.
- b) Equipment and vehicles will yield the right-of-way to wildlife.
- c) No personal pets, domestic or wild, will be allowed on site. However, if a dog is required for deference purposes, approval will be obtained.
- d) All personnel should be aware of the potential for encounters with black bears and instructed to immediately report all sightings to the Project Manager. At his discretion, the supervisor will notify the Forest Resources District Office in Springdale (709)673-3821/3823 and the Wildlife Division.
- e) When nuisance animals (e.g., black bear or beaver) are identified in the project area, the Project Manager will be responsible for all subsequent actions. Responsive actions will be determined by the Project Manager, who will consult with the Forestry Services District Office in Springdale and with the Inland Fish and Wildlife Division prior to any active intervention (except in emergency). All actions must comply with Inland Fish and Wildlife Division regulations and permits.
- f) The Project Manager must authorize the use of deterrent measures that include crackers and rubber bullets.
- g) Under provincial wildlife regulations, the displacement and release of any wild animal is the jurisdiction of the Forestry Branch and the Wildlife Division and is to be undertaken only under Wildlife supervision.
- h) A permit will be required to destroy nuisance animals; an approved firearm will be kept at site for that purpose. The Project Manager (or a representative of the Inland Fish and Wildlife Division) will determine if an animal is to be destroyed and will designate who will destroy the animal. The only firearm(s) allowed on-site are those under the control of the Project Manager (or his/her designate). Anytime an animal is destroyed, the Inland Fish and Wildlife Division will be notified.
- i) A draft report of the displacement or killing of a bear will be prepared by the Project Manager and provided to personnel involved. A detailed written report will be submitted to Anaconda, and the Inland Fish and Wildlife Division within 48 hours of killing a bear.

Authority:	Operations Manager	Issue Date:	November 1, 2017
Custodian:	Environmental Coordinator	Revision Date:	March 13, 2018
Issuing Department:	Environmental	Document No.:	1.3

3.3 Discovery of Historic Resources

Environmental Protection Procedures

In case of the discovery of a historic or pre-historic artifact or archeological site, the following procedures will apply:

- a) Under the *Historic Resources Act*, all archeological sites and artifacts are considered the property of the Crown and must not be disturbed. Aboriginal peoples and other residents of the Pine Cove area are also concerned about the preservation and protection of archeological and other cultural resources. Anaconda and the Contractor will take all reasonable precautions to prevent employees or other persons from removing or damaging any such articles or sites and may be held liable for prosecution under Sections 35.1 and 35.2 of the *Historic Resources Act* for all contraventions. Personnel working in the vicinity will be advised of the find. The site area will be flagged for protection and avoidance.
- b) All work will cease in the immediate area of the discovery until Anaconda advises the authorities of the discovery and, in consultation with the Provincial Archeologist, authorizes a resumption of the work. If required, a full assessment will be conducted of the site and immediate area.
- c) Archeological materials encountered will be reported initially to the Project Manager and immediately thereafter to Ms. Martha Drake, Resource Archeologist, Culture and Heritage Division, at (709) 729-2462, fax (709) 729-0870, with the following information:
 - i) nature of activity
 - ii) nature of material discovered; and
 - iii) precise location of the find.

Following the assessment of the significance and mitigation needs, a report will be made to Anaconda and the Culture and Heritage Division. Any proposed mitigation will first be approved by the Culture and Heritage Division.

3.4 Forest Fires

Environmental Protection Procedures

The fire prevention and fire-fighting procedures described below will be followed.

Anaconda or the Contractor will take all precautions necessary to prevent fire hazards when working at the site. These include but are not limited to:

- a) Disposal of all flammable waste on a regular basis.
- b) Anaconda or the Contractor making available, in proper operating condition, sufficient fire-fighting equipment to suit its labor force and fire hazards. The equipment will be maintained to the manufacturers standards and will be in accordance with the Opening Permit issued by the DNR during the Fire Season.
- c) Anaconda or the Contractor ensuring that its personnel are trained in the use of such equipment.

Authority:	Operations Manager	Issue Date:	November 1, 2017
Custodian:	Environmental Coordinator	Revision Date:	March 13, 2018
Issuing Department:	Environmental	Document No.:	1.3

- d) In case of a forest fire, Anaconda or the Contractor will take immediate steps to contain or extinguish the fire.
- e) Anaconda will appoint a supervisory staff member to undertake initial fire attack procedures and to act as liaison between company personnel and Department of Natural Resources firefighters should the situation require additional resources.
- f) All wildfires should be reported immediately to the Project Manager, the Springdale Forest Ecosystem District Office (709)673-3821 and the Regional Fire Duty Officer at Corner Brook (709) 637-2408. The following information will be provided.
 - I) Name of the person reporting the fire incident.
 - II) Telephone number of the person reporting the fire incident.
 - III) Location of the fire, referencing the name of the local area and the name of the nearest community.
 - IV) Time of fire detection.
 - V) Estimate of the fire size.
 - VI) Type of vegetation burning.
 - VII) Wind direction and estimate of wind speed.
 - VIII) Number of persons fighting the fire.
 - IX) Name of person supervising the fire-fighting activities and how that person may be contacted.
- g) THE RCMP will also be notified immediately at (709) 532-4221.

3.5 Mine Safety and First Aid

Environmental Protection Procedures

- a) An office complex will be designated as a marshalling point for all employees in case of an emergency. Further, a designated room will be maintained as an Emergency Control Centre to serve as a base of operations during a mine emergency. The room will contain the required communications equipment, written emergency procedures and a set of mine plans.
- b) A first aid station will be provided in the office/dry complex. There will be personnel with first aid training on-site always during operation. An emergency vehicle will be available always to take emergency cases to local hospitals if necessary.
- c) An emergency vehicle will be on-site. The vehicle will include equipment for environmental emergencies (i.e., special clothing and absorbent material)

Authority:	Operations Manager	Issue Date:	November 1, 2017
Custodian:	Environmental Coordinator	Revision Date:	March 13, 2018
Issuing Department:	Environmental	Document No.:	1.3

4 Contact List

For Fires:

Baie Verte Fire Department	(709) 532-4400
La Scie Fire Department	(709) 675-2459
Baie Verte RCMP Detachment	(709) 532-4221
24 Hour Forest Fire Emergency Line	(866) 709-3473

Hazardous Material Spills

Canadian Coast Guard	(709)-772-2083
----------------------	----------------

Authority:	Operations Manager	Issue Date:	November 1, 2017
Custodian:	Environmental Coordinator	Revision Date:	March 13, 2018
Issuing Department:	Environmental	Document No.:	1.3

5 Permits, Approvals and Authorizations

The following table lists permits, approvals and authorizations that may be required for the project.

Permit, Approval or Authorization	Issuing Agency
Provincial	
Approval of the Undertaking (Release from Envir. Assessment) Approval of Environmental Protection Plan (EPP) Approval of Environmental Effects Monitoring (EEM) Program	Minister of DOEC
Environmental Approval to Alter a Body of Water Drainage of Pasture Pond Diversion of Pine Cove Brook Infilling of small site ponds Construction of Conditioning Pond Construction of Polishing Pond Construction of Tailings Containment Area Site Drainage Environmental Approval for a Water Intake Structure/Withdrawal System Environmental Approval for Dams and Appurtenant Structures Tailings Containment Dam Conditioning Pond Dam Polishing Pond Dam Water Use License Environmental Permit for Culvert Installation Permit for all Watercourse Crossings	DOEC-Water Resources Management Division
Permit for Construction Permit for any Industrial or Processing Works	DOEC-Pollution Prevention Division
Permit to Occupy Crown Land	DOEC-Lands Branch
Permit to Control Nuisance Animals	DOEC-Inland Fish and Wildlife Division
Operating Permit Permit to Burn	DNR-Forest Resources
Approval of Development Plan, Rehabilitation Plan, Financial Security Mining Lease Mill License Surface Rights Lease	DNR-Mineral Development Division

Authority:	Operations Manager	Issue Date:	November 1, 2017
Custodian:	Environmental Coordinator	Revision Date:	March 13, 2018
Issuing Department:	Environmental	Document No.:	1.3

Permit, Approval or Authorization	Issuing Agency
Approval for Storing and Handling Gasoline and Associated Products Temporary Fuel Cache Fuel Tank Registration Approval of Design of Oil-water Separators for floor drains Approval for Collection, Storage and Transportation of Used Oil	GSC
Blasters Safety Certificates Magazine License Permit for a Water and Sewerage System Permit for an On-Site Sewage Disposal System Fire, Life and Safety Approval of Plans Building Accessibility Registration	GSC-Occupational Health and Safety Division
Approval of Human Resources Plan	Minister responsible for Status of Women
Federal	
Authorization for Works and Undertakings Affecting Fish Habitat	DFO
Approval to Conduct Work Over Navigable Waters	TC-Navigable Waters Protection
Radio Station License	Industry Canada
Temporary Magazine License Blasting Magazine License	Energy, Mines and Resources Canada Explosives Division
Municipal	
Development Permit Approval for Waste Disposal	Town of Baie Verte
DOEC - Newfoundland and Labrador Department of Environment and Conservation GSC - Newfoundland and Labrador Department of Government Services-Government Services Centre DNR - Newfoundland and Labrador Department of Natural Resources DFO-Department of Fisheries and Oceans TC - Transportation Canada	

Authority:	Operations Manager	Issue Date:	November 1, 2017
Custodian:	Environmental Coordinator	Revision Date:	March 13, 2018
Issuing Department:	Environmental	Document No.:	1.3

6 Literature Cited

(DOEC) Department of Environment and Conservation, 2004. Guidance Document for the Management of Impacted Sites. 18 pp + app.

Department Of Fisheries And Oceans 1995. Freshwater Intake End of Pie Fish Screen Guidelines

Grosse, M.M., A.S. Power, D.E. Hyslop and S.L. Pierce. 1998. Guidelines for Protection of Freshwater Fish Habitat in Newfoundland and Labrador. Fisheries and Oceans, St. Johns, NF. X+105 pp.,2 appendices

Wright, D.G. and G.E. Hopky. 1988. Guidelines for the use of explosives in or near Canadian Fisheries Waters. Can.Tech.Rep.Fish.Aquat.Sci.2107: iv+34p

6.1 Response Sequence

1. Assess fire, environmental and safety hazards.
2. Stop the flow.
3. Containment
4. Call your supervisor-assess the emergency using emergency classification Form A-1, section 8.0
5. Collection
6. Disposal and restoration
7. Reporting

The response sequence chart promotes smooth communications. If the sequence shown on the major-minor spill discovered chart section 6.2 is followed, we can effectively reduce the damage to the environment.

Authority:	Operations Manager	Issue Date:	November 1, 2017
Custodian:	Environmental Coordinator	Revision Date:	March 13, 2018
Issuing Department:	Environmental	Document No.:	1.3

6.2 Major-Minor Spill discovered

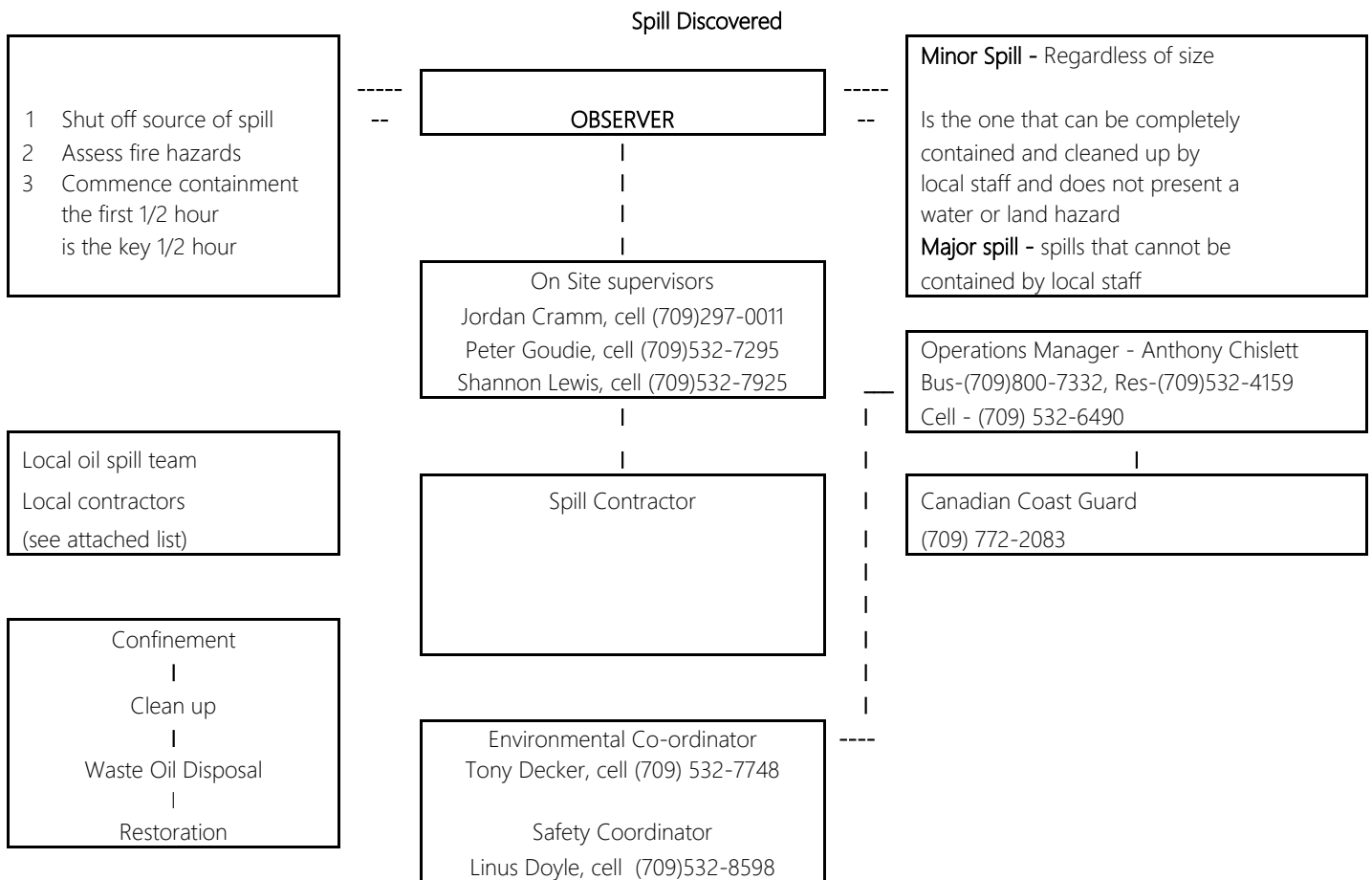

Authority:	Operations Manager	Issue Date:	November 1, 2017
Custodian:	Environmental Coordinator	Revision Date:	March 13, 2018
Issuing Department:	Environmental	Document No.:	1.3

6.3 Emergency Classification

Form A-1

1. Time and date emergency occurred or was first noticed:
2. Location:
3. Type of emergency:
4. Relevant conditions (wind, fog, tide, etc):
5. Area likely to be affected:
6. Origin of emergency:
7. Action already taken:
8. Persons notified:
9. Emergency classification (major or minor):
10. Person reporting emergency:
11. Time emergency reported:
12. Time emergency reported to government:
13. Product or material spilled:
14. Quantity of product or material spilled:
15. Status of containment:

6.4 Technique for handling a spill

Once a spill has occurred and been detected, the seven steps of our Response Sequence (section 6.1) must be carried out. How these are applied depends on the conditions under which we are working, on land or water, day or night, winter or summer, fog or sunshine, etc. No two spills can ever be expected to have the same set of combat conditions.

6.41 Assess the fire and safety hazards

If you know your product, you will be aware of the hazards it involves. Our first concern is the safety of the people threatened by a spill.

Authority:	Operations Manager	Issue Date:	November 1, 2017
Custodian:	Environmental Coordinator	Revision Date:	March 13, 2018
Issuing Department:	Environmental	Document No.:	1.3

6.42 Stop the Flow

The source of the leak must be sought, and the flow arrested. This can be done by closing a valve. Blocking a culvert, damming a ditch, etc. The idea is to halt the advance of the spill.

6.43 Containment

- i) Water based spills can be confined using booms. Booms can be floating type manufactured from synthetic fabrics or they may be made on site from logs, felled trees and bales of straw or wire fencing materials. The confinement efficiency of most booms can be enhanced by using a sorbent material such as polyethylene, straw, etc.
- ii) Land based spills can be impounded by digging a dyke. Sheets of polyethylene or vinylated plastic can be used to make the ground impervious to oil and prevent seepage into the ground water system.
- lii) Bulk A.N. spills can be controlled by collecting it in a pile, using a shovel and a rake.

6.44 Call your Supervisor-Assess the spill

Your immediate supervisor must be notified immediately to determine what resources will be necessary to clean up the spill. Form A-1 (Oil Spill Classification Chart section 6.3) has been designed to serve two purposes; first, it contains important information concerning the nature of the spill; secondly, it is used to help determine whether the spill is minor or major and therefore which line of communication should be followed. By using this Classification chart, you will be able to quickly determine how much equipment will be necessary and the amount of outside help that you will need. Once the employee has notified his supervisor, he should return to spill site to keep watch over its progress and resume containment procedures. The supervisor, by referring to his Response Sequence Chart (Section 6.2) will notify the appropriate people of the spill.

6.45 Spill Containment on Water

Containment: Oils spilled on water will rapidly spread out to form a thin film over a wide area thus making clean-up more difficult to complete. To prevent this, a boom can be effectively used, with its limitations.

Often a sorbent material will have to be used to soak up the oil before collection. This is usually necessary for thin slicks and for very heavy oils that become difficult to pump on cold water. Some sorbents are pump able, but you might have to resort to manual pick-up of oil-soaked sorbents with pails, pitchforks, etc. Sorbent pads are applied to land or water spills and can be wrung out and re-used. They repel water, therefore yielding an almost pure product upon recovery.

Sorbents and booms are also used to protect hard-to-clean places from becoming contaminated by an approaching oil slick. By lining the shore of a beach, the boats in a marina or any other area likely to be affected by a spill, the oil can be kept away from these sensitive areas and be collected at the same time.

Authority:	Operations Manager	Issue Date:	November 1, 2017
Custodian:	Environmental Coordinator	Revision Date:	March 13, 2018
Issuing Department:	Environmental	Document No.:	1.3

If booms were required, they would have to be supplied by an outside agency. Section 4.0 and 6.2 list appropriate contacts.

6.46 Oil Slick Movement

The presence of wind is assumed to generate an instantaneous surface current with a magnitude of 3.5% of the wind speed. This current is assumed to directly transport the slick 10 degrees to the right of the wind.

Waves, produced by the wind, limit the effectiveness of the booms. Multiple booms may have to be used to reduce the loss of product due to wave action.

6.47 Spill Containment on Land

Spills on land present two major hazards:

- i) Pollution of Open Natural Watercourse (small stream, lakes):

The simplest method of containing an oil spill on flowing streams is to use a rigid boom, if it can be sealed into banks (packed with straw, etc.) to stop leaks around it. Installing a culvert and using earth to partially dam the flow is also an effective method of collecting the oil together. A dam made from bales of straw on slow moving water can be effective in separating the oil and collecting it together. This should be followed by a second (straw bale or other) boom, a technique which may be necessary as a guard against slicks which get past the rigid types mentioned above.

Damage to Private Property

Oil spills can occur on private property and the smallest spills can create difficult legal battles. For this reason, all spills, regardless of size, must be reported to your supervisor and to the Team Captain. Immediate clean-up of spills on asphalt, grass, gardens, basements, etc. will reduce the total damage. During clean-up, be careful not to track oil around on boots, remove too much soil or drive vehicles over the property.

6.48 Oil spilled on Ice

Oil spilled on or under ice is especially difficult to clean up. Since evaporation under these conditions is reduced, the main method of clean-up must be mechanical. Burning is extremely difficult and the action of the wind and waves, useful in non-ice conditions has no effects. Recent experience has proven one technique (like trenching) to be quite effective. When oil has been spilled onto or under the ice, pits can be dug in the ice (but not all the way through) by cutting out blocks with a chain saw or ice saw. Once a trough of about 3 feet by 10 feet has been dug, the surface oil can be directed onto it and pumped off. Oil that has soaked into the ice will flow into the pits. Finally, oil that is under the ice will tend to soak through, by capillary action and collect through the trough.

Authority:	Operations Manager	Issue Date:	November 1, 2017
Custodian:	Environmental Coordinator	Revision Date:	March 13, 2018
Issuing Department:	Environmental	Document No.:	1.3

6.49 Collection

Oil Recovery: After an oil spill has been contained, and if possible, corralled into a small area, the next step is removal from the surface. An oil skimmer can be employed to skim oil from the surface of the water for pickup by a diaphragm pump or vacuum truck and appropriate hose arrangement. The skimmer is normally positioned on the upstream side at the shore end of each boom. The discharges from the pump can be directed into a tank, truck, lined earthen pit, etc.

Absorbents such as sorbent pads, Speedi-dri, peat moss, straw, etc., expanded foams, etc., can be used to soak up oil. There is no simple method of pick-up of most absorbents from the water surface. Pitchforks or basket screens can be used for peat moss and straw when these materials have been used. Some synthetic sorbents are pump able, and sorbent pads can be collected manually, wrung out and used again. In general, peat moss and straw are used on land and synthetic sorbents on water. Speedi-dri is most effective on concrete, Oil should be pumped without the use of sorbents if possible. Peat moss and straw might have to be used on water for heavier oils (bunker or crude).

In some cases, oil can be removed from absorbents by squeezing or water leaching onto an impervious sheet or collecting system. This oil can be sent back through a refinery system or sent to a disposal site.

Other methods

Conditions will often prevent the collection of spilled oil. Although we must make every effort to collect as much product as possible, spills on the water, especially in large bodies of water, have seldom occurred under ideal conditions, and containment is difficult.

Dispersants

Natural wave action and microbial degradation of the oil will, over time, break up the slick. IF APPROVAL IN WRITING HAS BEEN OBTAINED FROM GOVERNMENT AUTHORITIES, DISPERSANTS MAY BE APPLIED TO AN OIL SLICK TO SPEED UP THE PROCESS. This is sometimes done to protect wildlife feeding or breeding areas further downstream.

The Ministry of Transport and some oil companies have various dispersants in stock throughout the Region.

Burning

Burning of product on land and water must never be done without clearance from Government authorities and with due regard to human and animal safety. Precautions must be taken to prevent the possibility of the fire spreading. Burning of gasoline and other light products is never recommended because of the explosion hazards that exist.

Sinking: SHOULD NEVER BE DONE

Authority:	Operations Manager	Issue Date:	November 1, 2017
Custodian:	Environmental Coordinator	Revision Date:	March 13, 2018
Issuing Department:	Environmental	Document No.:	1.3

Sinking, as a way of clean-up should **never** be considered. WE cannot hide the spill “under the carpet”; it usually does not stay at the bottom anyway. Sunken oil usually re-surfaces after a short period, even when chemical or mechanical sinking agents have been used.

Herding

Herding agents can be used in some circumstances, after approval from the Government; and should be used only by experienced personnel who are familiar with the techniques.

6.49 Disposal and Restoration

Collected oil can often be run through the refinery processes if there is essentially no solids content. Oily water may possibly be disposed of through an API or similar separator and treating system. Oil soaked straw, peat, sand, soil, etc. is most easily disposed of by burial, or open microbial action. Government approved sites in Stephenville and Corner Brook may be used for the disposal of approved contaminated material.

DISPOSAL SHOULD NEVER BE THROUGH DRAINAGE OR SEWER SYSTEMS.

Oil saturated beaches should be cleaned in the following order of preference:

1. Absorption of the oil by materials, such as peat moss, straw, sorbent pads, etc.:
2. Physical removal of contaminated sand, gravel or stones by hand or by machinery;
3. High pressure water washing of freshly deposited oil may help reduce accumulations; and
4. Chemical cleaning – BUT WITH GOVERNMENT APPROVAL.

Collected oil-soaked sand and soil may be washed in a suitable location to reduce the oil content. The oil and water from this location should be collected and sent to a recovery system or disposal area. Small quantities of earth or sand can be restored to a reusable condition by burning off the oil or by ploughing the small quantity into the soil and fertilizing the area. Adequate precautions should be used un burning operations. Government approval is required for burning oil waste.

6.50 Reporting

Final reports of oil spill incidents are an important part of our prevention program. The causes of the spill, as well as the experience of various actions taken, help is to improve our techniques and perhaps reduce the incidence of oil spills.

Oil Spill Reports should contain all the information relevant to the spill, including the events leading up to the spill, the response sequence followed (and its success or failure), action taken to contain and clean up the spill (including any outside contractor or co-operative help used), and all the data relevant to the incident (such as amount and type of product spilled, estimated or actual cost of clean-up, etc.) The report should include recommendations as to how that type of spill could be prevented in the future.

Authority:	Operations Manager	Issue Date:	November 1, 2017
Custodian:	Environmental Coordinator	Revision Date:	March 13, 2018
Issuing Department:	Environmental	Document No.:	1.3

The report should be accompanied by, a copy of Form A-1 (filled out at the time of the spill) as well as an Accident Investigation Report.

Summary: See section 6.1 for the seven basic steps of our response sequence.

6.51 Duties

Observer – assess the hazard to one’s own health and safety and to others in the vicinity. If danger is eminent, then leave the area and warn others to leave also. Notify your supervisor immediately.

Supervisor – The Supervisor assumes control of all Company activities associated with an environmental emergency within the designated area. The supervisor is also responsible for contacting the Plant Manager with the following information.

- Name of person discovering the spill
 - Time of the incident
 - Location of the incident
 - Type of Emergency
 - Cause of the incident (if known)
 - Current weather conditions
 - Any potential for hazard or injury to people, wildlife or marine environment.
 - Whether a fire or explosion hazard exist
 - Action already taken
- The supervisor will co-ordinate the assistance rendered by industry co-operatives.
 - Develop and maintain a communication network with industry in his area.
 - Assume responsibility for directing initial Company action on a spill in accordance with the Environmental Emergency Contingency Plan.
 - Prepare the final report in consultation with the Plant Manager.
 - The Supervisor has the authority to summon Company personnel, industry, co-ops and contractors.

Plant Manager – In the event of an emergency, the Plant Manager or other designate will immediately inform the following:

- Vice President of Operations
- Safety Coordinator
- Canadian Coast Guard at (709) 772-2083

The Plant Manager will arrange for the disposal of any recovered spill material and, upon completion of the clean-up and restoration, prepare, in consultation with the supervisor, a spill report.

Authority:	Operations Manager	Issue Date:	November 1, 2017
Custodian:	Environmental Coordinator	Revision Date:	March 13, 2018
Issuing Department:	Environmental	Document No.:	1.3

Safety/Environmental Coordinator – The Safety/Environmental Coordinator will maintain contact with, advise and coordinate work crews undertaking the actual clean-up of the emergency. After successful clean-up is complete, the Safety/Environmental Coordinator will:

- Ensure the Environmental Emergency Contingency Plan is up-to-date with all potentially hazardous materials listed and all names of personnel and phone number are accurate.
- Be responsible to assessing new emergency hazards as they develop and take preventative actions, whether covered in this plan or not.
- Check and maintain the operating status of required response equipment which may be required for an emergency.

6.52 Local Operating Unit

Function

In the event of an oil spill, the unit, within its capability, will confine, clean up, restore and dispose of the spilled oil.

Work Force

Hourly and Salaried staff and contract forces assigned to the team by the Supervisor

Relationship

Normal line responsibility for the operation concerned. In case of major spills beyond the capability of the operating unit, local co-operatives, industry and Government are to be summoned.

Responsibilities

To operate in accordance with Company procedures and in a manner to prevent oil spills.

In the event of a spill, immediately commence confinement and clean-up operations and report the spill as provided for in the Response Operations (6.1)

When it is determined that a spill is beyond the capability and/or capacity of the unit, the local co-operative must be mobilized. Contact must be made with Pardy's Waste Management and Industrial Services and a User's agreement must be signed before unit can be moved to site.

Maintain inventory of materials and equipment in good condition for oil spill emergencies.

6.53 Winter Spills

Product, which has been spilled in the winter, presents a very specific problem. On one hand, the frozen ground helps reduce the penetration of the oil. On the other hand, the snow hides the spill and hampers clean-up procedures. And, of course, winter spills are characterized by another factor, the cold. Spills,

Authority:	Operations Manager	Issue Date:	November 1, 2017
Custodian:	Environmental Coordinator	Revision Date:	March 13, 2018
Issuing Department:	Environmental	Document No.:	1.3

on ice covered water present further complications. Clean-up procedures on ice are covered in Section 3.

Prevention – many of the spills experienced in winter cold could have been prevented. They fall into two basic categories, human error and faulty equipment and often the combination of the two.

It is important that lines and pumps be kept free of snow and ice. In this way, minor leaks can be detected before they develop into major catastrophes. Every plant should make an extra effort to prepare for winter, before the snow comes, so that the equipment is in a condition to withstand the abuses our climate will present.

Human error accounts for more than 50% of all spills. Winter conditions can invite “short-cuts” or risk taking at the expense of safe operating procedures. We know how cold it is watching a tank being filled at 2:00am in -20-degree weather but we also know that is dangerous not to walk the line and check the tank.

Clean-up – the procedure for clean-up in winter is the same as for any other time of the year. See Chapter 6.

The same conditions that make clean-up in winter difficult also increase the chances that spills will occur. The prevention of oil spills once again become our best contingency plan.

Appendix I

Cross Sections of Waste Stockpiles

argyle_wastedump_15_volume_solid_dtm_02

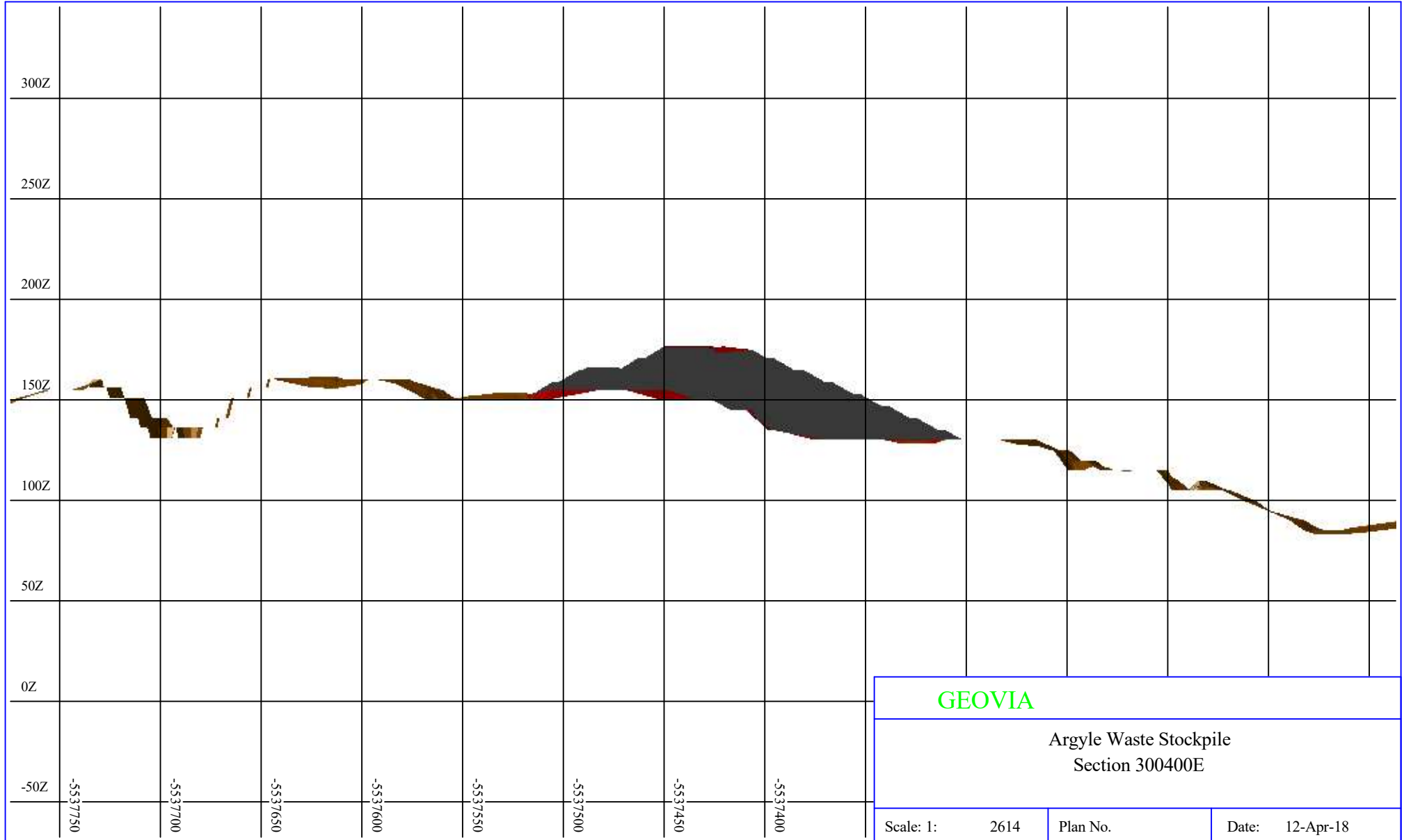

GEOVIA			
Argyle Waste Stockpile Section 300400E			
Scale: 1:	2614	Plan No.	Date: 12-Apr-18

argyle_wastedump_15_volume_solid_dtm_07

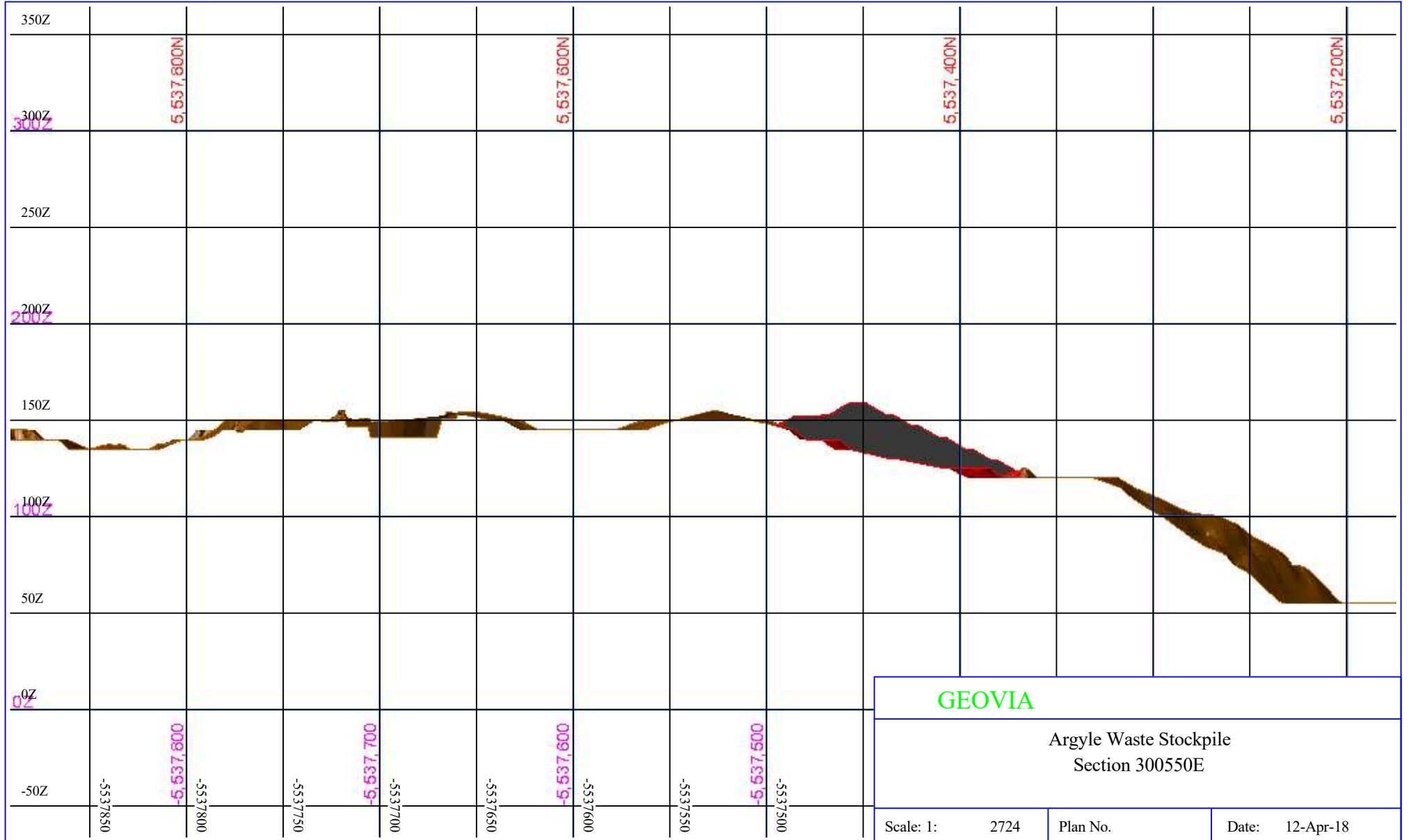

SURPAC - GEOVIA

argyle_wastedump_15_volume_solid_dtm_06

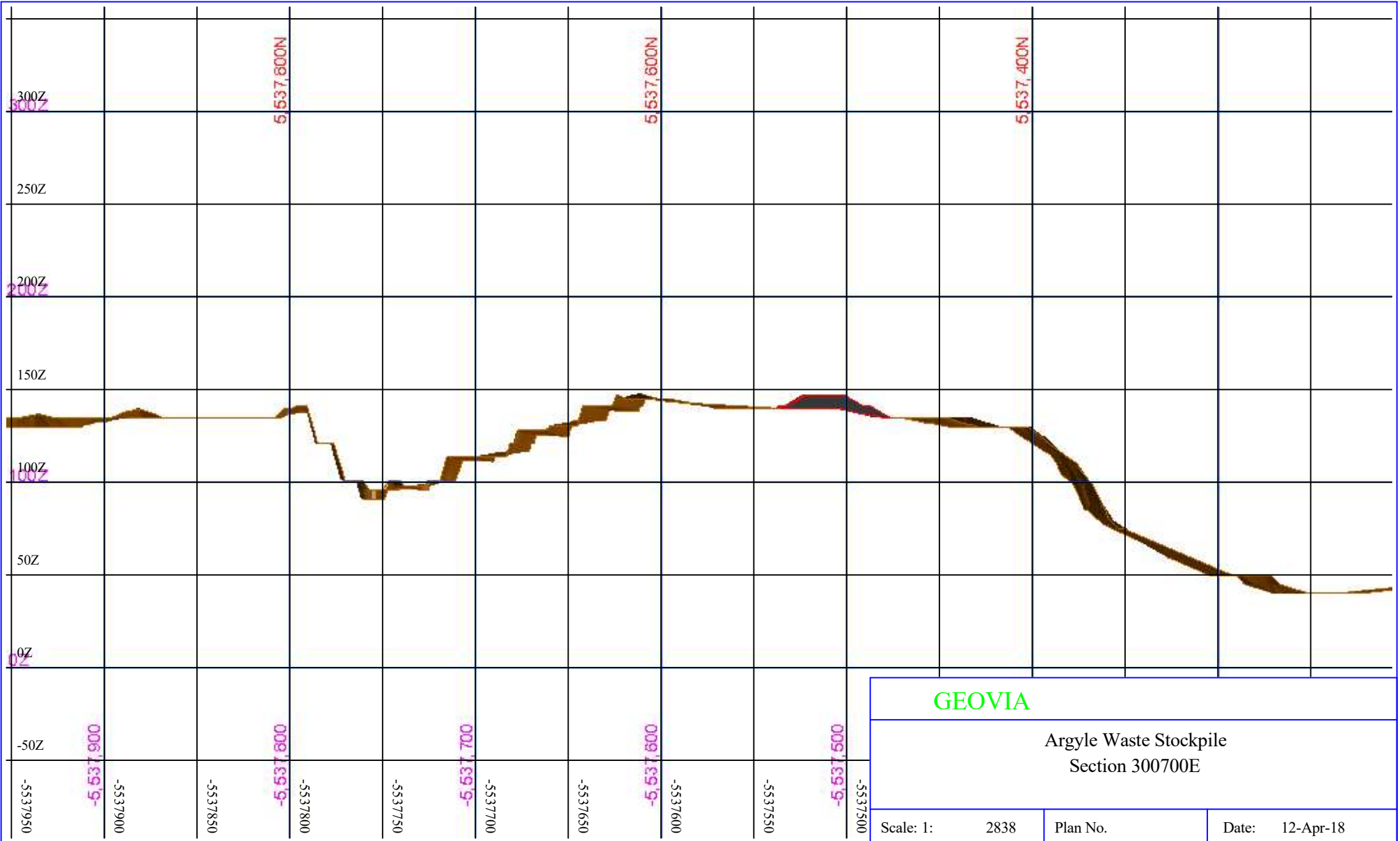

SURPAC - GEOVIA

Appendix J

RPC Metallurgical Testing Results

Final Report

Argyle Prospect – Metallurgical Test Program Anaconda Mining Inc.

Reference No.: MIS-J2048

Prepared for:

Ms. Gordana Slepcev and Mr. Chris Budgell
Anaconda Mining Inc.
Pine Cove Mine
Baie Verte, NL A0K 1B0

December 13, 2017

Prepared by:

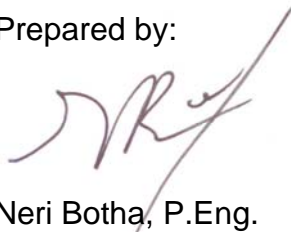

Neri Botha, P.Eng.
Extractive Metallurgist
Minerals & Industrial Services

Reviewed by:

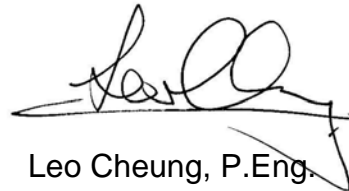

Leo Cheung, P.Eng.
Department Head
Minerals & Industrial Services

INTRODUCTION

Anaconda Mining Inc. initiated a study at RPC to investigate the potential of treating material from the greater Argyle Prospect Area with the current mill operation at Pine Cove Mine. The Argyle Prospect material is being investigated by Anaconda Mining Inc. in conjunction with RPC to look at ways of expanding current operations.

The results from previous test work on the Pine Cove Mine Main Zone (RPC Report Reference No.: MIS-J1900) indicated that an Au recovery of 98.6 % could be obtained in a flotation concentrate grading at 51 g/t Au in 5.1 % of the mass. The current circuit employs grinding followed by flotation, regrinding and cyanidation. During cyanidation on the flotation concentrate at 83 % passing 20 µm, 88.3 % of the Au was extracted (RPC Report Reference No.: MIS-J1900).

Geological data from the greater Argyle Prospect Area has indicated that this material could have areas with high gold contents or where there is a nugget effect. RPC was thus contacted to conduct a test work scope that primarily entailed flotation, centrifugal gravity concentration test work and cyanidation testing to evaluate the response of Argyle Prospect material to current plant grinding and flotation conditions as well as the potential requirement for gravity concentration in comparison to the Main Zone.

This report serves to summarize the findings as well as recommendations for the way forward.

PROGRAM RESULTS

Sample Preparation and Head Analysis

Several Argyle core samples were received, dried, crushed to -¼” and blended to form the sample detailed in Table 1.

Once prepared, the sample was homogenized prior to splitting into respective sub-samples according to RPC standard operating procedures for flotation and cyanidation test work. One sub-sample was submitted for whole rock analysis, multi-element head ICP assay as well as Au fire assay and these results were presented in Table 2.

Table 1
Argyle Core Sample Blending Ratio

Sample ID	Mass (kg)	Sample ID	Mass (kg)
203664	0.44	204357	0.64
203665	0.53	204358	0.50
203666	0.62	205089	0.62
203667	0.54	205090	0.74
203668	0.66	205091	0.70
203669	0.48	205092	0.54
203670	0.52	205244	0.54
204342	0.72	205245	0.70
204343	0.56	205246	0.78
204344	0.34	205247	0.80
204345	0.48	205248	0.72
204346	0.46	205251	0.80
204347	0.62	205252	0.74
204348	0.75	205253	0.82
204351	0.70	205254	0.58
204352	0.70	205255	0.76
204353	0.64	205256	0.54
204354	0.56	205257	0.66
204355	0.62	205258	0.32
204356	0.68	205259	0.60

Table 2
Head Chemical Analysis on Argyle Sample

ICP-OES		ICP-OES	
ID	mg/kg	ID	mg/kg
Ag	<1	Sr	129
Al	68853	Ta	<50
As	72	Te	<50
Ba	63	Ti	7505
Be	1.1	Tl	<50
Bi	<25	V	137
Ca	39833	W	<50
Cd	<5	Zn	105
Ce	<25	Zr	180
Co	38	Whole Rock	
Cr	296	ID	Wt. %
Cu	29	Al ₂ O ₃	13.87
Fe	83159	BaO	<0.01
Ga	<25	CaO	5.67
Ge	<50	Cr ₂ O ₃	0.06
In	<100	Fe ₂ O ₃	11.85
K	8085	K ₂ O	1.01
La	20	MgO	2.16
Li	<10	MnO	0.20
Mg	11654	Na ₂ O	4.07
Mn	1269	P ₂ O ₅	0.64
Mo	46	SiO ₂	52.97
Na	26655	SrO	0.02
Nb	<25	TiO ₂	2.06
Ni	215	V ₂ O ₅	0.04
P	2578	ZrO ₂	0.06
Pb	<25	LOI 1000°C	6.76
S	9457	Total	101.44
Sb	<50	Fire Assay	
Se	<50	ID	mg/kg
Sn	<50	Au	1.794

Grind and Liberation Characteristics

A milling curve was generated for the Argyle sample. A 7.5 in. diameter stainless steel laboratory rod mill was utilized (12 in. length) at a mill speed of 71 rpm with a sample charge of 2 kg and 1 L water (67 % solids). The rod charge comprised of three 7/8 in. and eighteen 1/2 in. stainless steel rods with a total mass of 8.5 kg. Intervals of 30, 60, 90 and 120 minutes were evaluated, and the resulting milling curve is given in Figure 1. Malvern sizing analyses were carried out on each timed interval.

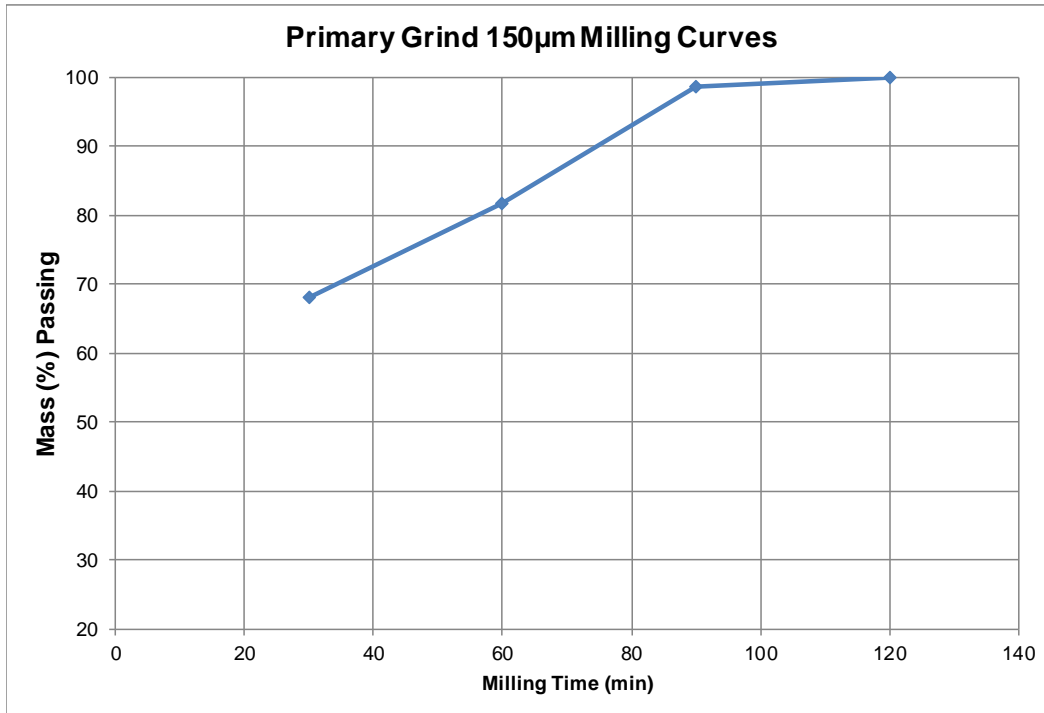

Figure 1: Milling Curve Generated for Argyle Sample.

The milling curve seen in Figure 1 was similar to that obtained on the Main Zone (RPC Report Reference No.: MIS-J1900) and grindability test work on the Argyle Prospect is recommended to confirm this finding.

Utilizing the milling curve (Figure 1), four respective size fractions were generated for preliminary flotation test work to assess the liberation characteristics of the Argyle Prospect material. These four size fractions were as follows: 70 % passing 150 µm, 80 % passing 150 µm, 90 % passing 150 µm and 100 % passing 150 µm.

Flotation test work was carried out utilizing the flow sheet illustrated by Figure 2 with conditions as laid out in Table 3.

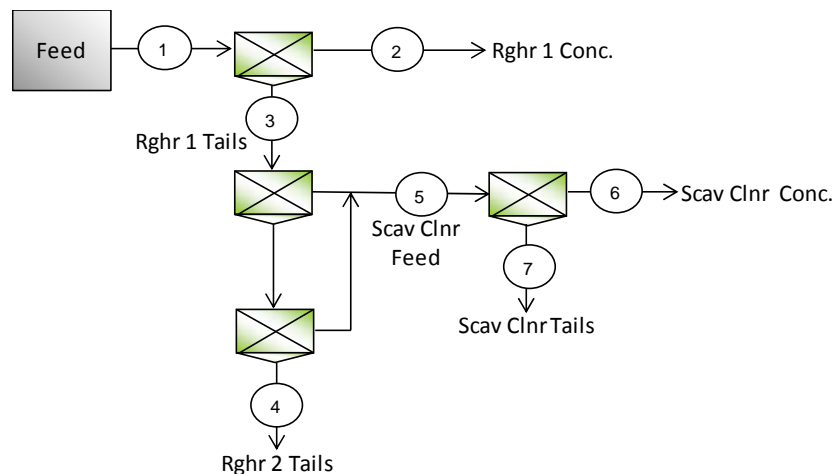

Figure 2: Liberation Flotation Test Work Flow Sheet.

**Table 3
 Liberation Flotation Operating Conditions**

TEST 1									
Evaluate a Grind of 70% passing 150µm									
Stage	Reagents (g/t of Feed Ore)			Residence Time (min)			pH	P₈₀ (µm)	(%) Passing 150µm
	PAX	Lime	MIBC	Grind.	Cond.	Flot.			
Primary Grind				34				236	70
Rougher 1	8	as required	25		3	5	8.5		
Rougher 2	9	as required			3	10	8.5		
Scav Cleaner		as required	25		1	5	8.5		
TEST 2									
Evaluate a Grind of 80% passing 150µm									
Stage	Reagents (g/t of Feed Ore)			Residence Time (min)			pH	P₈₀ (µm)	(%) Passing 150µm
	PAX	Lime	MIBC	Grind.	Cond.	Flot.			
Primary Grind				56				150	80
Rougher 1	8	as required	25		3	5	8.5		
Rougher 2	9	as required			3	10	8.5		
Scav Cleaner		as required	25		3	5	8.5		
TEST 3									
Evaluate a Grind of 90% passing 150µm									
Stage	Reagents (g/t of Feed Ore)			Residence Time (min)			pH	P₈₀ (µm)	(%) Passing 150µm
	PAX	Lime	MIBC	Grind.	Cond.	Flot.			
Primary Grind				75				104	90
Rougher 1	8	as required	25		3	5	8.5		
Rougher 2	9	as required			3	10	8.5		
Scav Cleaner		as required	25		3	5	8.5		
TEST 4									
Evaluate a Grind of 100% passing 150µm									
Stage	Reagents (g/t of Feed Ore)			Residence Time (min)			pH	P₈₀ (µm)	(%) Passing 150µm
	PAX	Lime	MIBC	Grind.	Cond.	Flot.			
Primary Grind				93				65	100
Rougher 1	8	as required	25		3	5	8.5		
Rougher 2	9	as required			3	10	8.5		
Scav Cleaner		as required	25		3	5	8.5		

The cumulative results are summarized in Table 4 and detailed results can be found in the Appendix.

Table 4
Cumulative Results for Argyle Flotation Test Work per Grind

% Passing 150µm	No.	Stream Name	Mass Dist. (%)	Grade	Distribution
				Au (g/t)	Au (%)
70	2	Rghr 1 Conc	2.6	58.49	86.0
	2+6	Rghr 1 & Scav Clnr Conc	2.8	56.52	89.2
	2+6+7	Rghr 1 & 2 Conc	4.2	39.20	91.7
	2+6+7+4	Total	100.0	1.78	100.0
% Passing 150µm	No.	Stream Name	Mass Dist. (%)	Grade Au (g/t)	Distribution Au (%)
80	2	Rghr 1 Conc	3.4	85.83	93.8
	2+6	Rghr 1 & Scav Clnr Conc	3.5	83.74	95.4
	2+6+7	Rghr 1 & 2 Conc	4.6	63.98	95.9
	2+6+7+4	Total	100.0	3.09	100.0
% Passing 150µm	No.	Stream Name	Mass Dist. (%)	Grade Au (g/t)	Distribution Au (%)
90	2	Rghr 1 Conc	4.0	52.48	94.2
	2+6	Rghr 1 & Scav Clnr Conc	4.3	49.64	96.0
	2+6+7	Rghr 1 & 2 Conc	6.3	34.14	96.7
	2+6+7+4	Total	100.0	2.23	100.0
% Passing 150µm	No.	Stream Name	Mass Dist. (%)	Grade Au (g/t)	Distribution Au (%)
100	2	Rghr 1 Conc	4.6	42.18	94.9
	2+6	Rghr 1 & Scav Clnr Conc	4.7	41.02	96.0
	2+6+7	Rghr 1 & 2 Conc	6.0	32.85	96.5
	2+6+7+4	Total	100.0	2.03	100.0

Table 4 indicated that all four grind sizes tested on the Argyle material resulted in high Au recoveries. At a grind size of 80 % passing 150 µm, which is currently employed at the Pine Cove mill, a cumulative concentrate containing a high Au grade of 63.98 g/t in 4.6 % of the mass at an Au recovery of 95.9 % could be produced. When the liberation was increased to 90 % passing 150 µm the Au recovery in the cumulative concentrate was further increased to 96.7 % at a lower Au grade of 34.14 g/t Au in 6.3 % of the mass.

Flotation Reagent Scoping

Based on the results from grind and liberation characteristics test work a 90 % passing 150 µm grind size was selected for flotation reagent scoping test work as this corresponded to the highest Au recovery. This grind size related to 80 % of the mass passing 104 µm. The flow sheet reported in Figure 2 was employed with operating conditions as laid out in Table 5.

Table 5
Reagent Scoping Flotation Operating Conditions

TEST A										
Evaluate a Grind of 90% passing 150µm and Incorporate 34g/t Danafloat 233										
Stage	Reagents (g/t of Feed Ore)				Residence Time (min)			pH	P₈₀ (µm)	(%) Passing 150µm
	PAX	Lime	Danafloat 233	MIBC	Grind.	Cond.	Flot.			
Primary Grind			-		75				104	90
Rougher 1	8	as required	-	25		3	5	8.5		
Rougher 2	9	as required	34			3	10	8.5		
Scav Cleaner		as required	-	25		1	5	8.5		
TEST B										
Evaluate a Grind of 90% passing 150µm and Incorporate 50g/t Danafloat 233										
Stage	Reagents (g/t of Feed Ore)				Residence Time (min)			pH	P₈₀ (µm)	(%) Passing 150µm
	PAX	Lime	Danafloat 233	MIBC	Grind.	Cond.	Flot.			
Primary Grind			-		75				104	90
Rougher 1	8	as required	-	25		3	5	8.5		
Rougher 2	9	as required	50			3	10	8.5		
Scav Cleaner		as required	-	25		3	5	8.5		
TEST C										
Evaluate a Grind of 90% passing 150µm and Incorporating Flex 51 instead of PAX										
Stage	Reagents (g/t of Feed Ore)				Residence Time (min)			pH	P₈₀ (µm)	(%) Passing 150µm
	PAX	Lime	Danafloat 233	MIBC	Grind.	Cond.	Flot.			
Primary Grind			-		75				104	90
Rougher 1	8	as required	-	25		3	5	8.5		
Rougher 2	9	as required	-			3	10	8.5		
Scav Cleaner		as required	-	25		3	5	8.5		
TEST D										
Evaluate a Grind of 90% passing 150µm Incorporating 34g/t Danafloat 233 and Flex 51 instead of PAX										
Stage	Reagents (g/t of Feed Ore)				Residence Time (min)			pH	P₈₀ (µm)	(%) Passing 150µm
	Flex 51	Lime	Danafloat 233	MIBC	Grind.	Cond.	Flot.			
Primary Grind			-		75				104	90
Rougher 1	8	as required	-	25		3	5	8.5		
Rougher 2	9	as required	34			3	10	8.5		
Scav Cleaner		as required	-	25		3	5	8.5		

The results were cumulated and presented in Table 6 with the full results disclosed in the Appendix.

Table 6
Cumulative Results for Flotation Reagent Scoping Tests

Condition Test ID	No.	Stream Name	Mass Dist. (%)	Grade	Distribution
				Au (g/t)	Au (%)
A	2	Rghr 1 Conc	4.0	75.64	93.9
	2+6	Rghr 1 & Scav Clnr Conc	4.2	73.43	96.7
	2+6+7	Rghr 1 & 2 Conc	6.1	50.86	97.0
	2+6+7+4	Total	100.0	3.21	100.0
Condition Test ID	No.	Stream Name	Mass Dist. (%)	Grade	Distribution
B	2	Rghr 1 Conc	3.9	69.49	96.0
	2+6	Rghr 1 & Scav Clnr Conc	4.2	64.32	97.0
	2+6+7	Rghr 1 & 2 Conc	6.8	40.42	97.3
	2+6+7+4	Total	100.0	2.81	100.0
Condition Test ID	No.	Stream Name	Mass Dist. (%)	Grade	Distribution
C	2	Rghr 1 Conc	3.9	61.68	94.7
	2+6	Rghr 1 & Scav Clnr Conc	4.1	59.13	95.5
	2+6+7	Rghr 1 & 2 Conc	5.9	42.10	95.9
	2+6+7+4	Total	100.0	2.57	100.0
Condition Test ID	No.	Stream Name	Mass Dist. (%)	Grade	Distribution
D	2	Rghr 1 Conc	5.3	34.40	94.3
	2+6	Rghr 1 & Scav Clnr Conc	5.6	32.88	95.7
	2+6+7	Rghr 1 & 2 Conc	7.9	23.38	96.2
	2+6+7+4	Total	100.0	1.92	100.0

The results as seen in Table 6 indicated that an improvement in Au grade to the cumulative concentrate was obtained through the use of Danafloat 233 (Test A and Test B) while the use of Flex 51 resulted in lower Au cumulative concentrate grades and recoveries. For comparative purposes, these results were combined with those of Table 4 to produce the grade recovery curves of Figure 3.

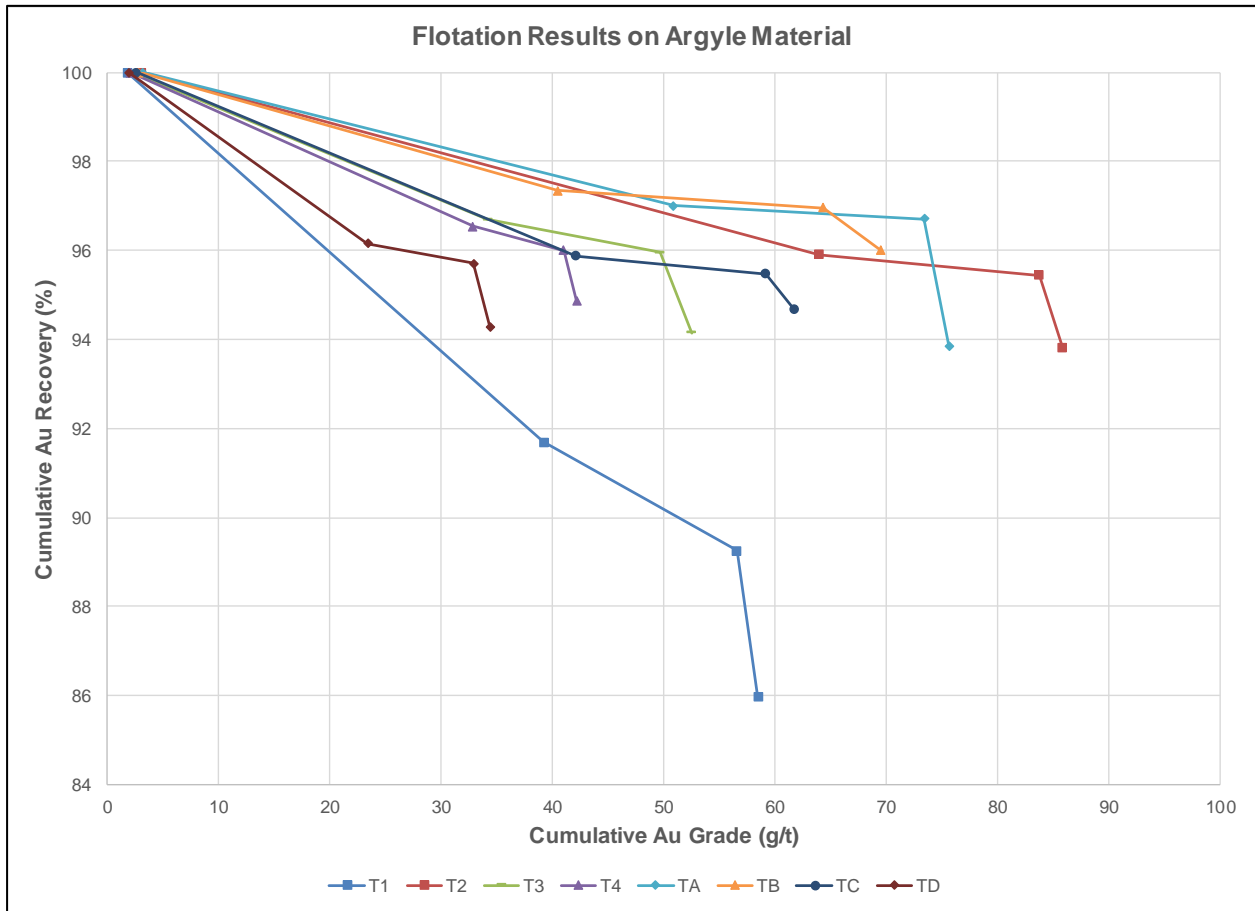

Figure 3: Au Flotation Grade Recovery Curves.

Optimal grade and recovery results were thus obtained in Test B (see Figure 3 and compare Table 4 to Table 6) were a grind size of 90 % passing 150 µm was employed with 50 g/t of Danafloat 233. This test was able to produce a cumulative concentrate grade of 40.42 g/t Au in 6.8 % of the mass at an Au recovery of 97.3 %. Further reagent scoping flotation test work on the 80 % passing 150 µm size class is recommended to evaluate the extent to which the addition of Danafloat 233 could increase Au recovery at that size.

Centrifugal Gravity Concentration Test Work

Based on the flotation results obtained, final tailings grades after flotation were very low ranging from 0.15 g/t Au at 70 % passing 150 µm to 0.07 g/t Au at 100 % passing 150µm (see Table 15 and Table 19 in the Appendix). Centrifugal gravity concentration testing was thus not conducted on fresh Argyle feed at varying grind sizes as opposed to flotation tailings.

A bench scale Knelson concentrator, as shown in Figure 4, was utilized to treat the Argyle feed material at varying grind sizes. The aim was to evaluate what proportion of coarse Au could be captured via gravity separation prior to flotation.



Figure 4: Bench Scale Knelson Concentrator.

The operating conditions for the set up as indicated in Figure 4 consisted of a water flow rate of 4 L/min (1.6 psi) with a feed rate of 480 mL/min (the feed slurry contained 22% solids) and a G-force corresponding to 60G. Feed top sizes of 1.18 mm, 850 µm, 600 µm and 425 µm were evaluated.

The results produced are provided in Table 7.

**Table 7
 Results from Knelson Test Work on Prepared Argyle Size Fractions**

Top Size (µm)	Stream	Mass (%)	Grade	Distribution
			Au (g/t)	Au (%)
1180	Conc.	10.5	8.47	40.7
	Tails	89.5	1.45	59.3
	Calc. Head	100.0	2.19	100.0
850	Conc.	8.1	9.97	42.8
	Tails	91.9	1.18	57.2
	Calc. Head	100.0	1.89	100.0
600	Conc.	7.6	12.51	43.1
	Tails	92.4	1.36	56.9
	Calc. Head	100.0	2.21	100.0
425	Conc.	8.0	13.80	48.9
	Tails	92.0	1.26	51.1
	Calc. Head	100.0	2.26	100.0

Table 7 showed that through centrifugal gravity concentration at a coarse liberation size of 100 % passing 425 µm, a concentrate containing 13.80 g/t Au could be produced in 8.0 % of the mass with an Au distribution of 48.9 %. Further test work is recommended on even greater liberation to evaluate the extent to which Au grade and recovery in the gravity concentrate could be further increased.

Cyanide Leaching Characterization at a P80 of 20 µm

A regrind milling curve was generated for the Argyle sample prepared into the 80 % passing 47 µm grind size (primary grind of 120 minutes). An 8-in. diameter laboratory stirred mill was utilized (8 in. length) with a sample charge of 300 g and 530 mL water (36 % solids). The ball charge comprised of 2 mm diameter ceramic beads to give a total mass of 2 kg. Intervals of 5, 10, 20 and 30 minutes were evaluated, and the resulting milling curve is given in Figure 5. Malvern sizing analyses were carried out on each timed interval.

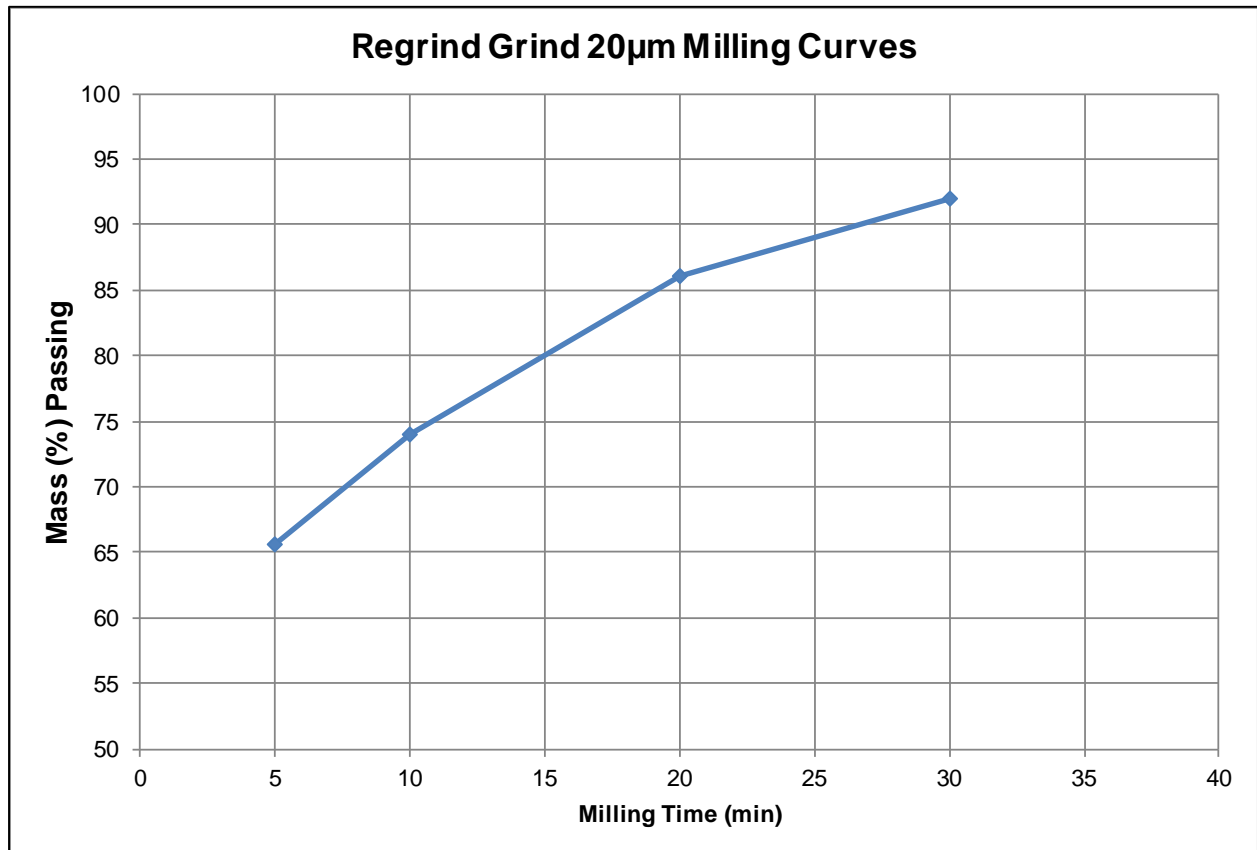

Figure 5: Regrind Milling Curve Generated for Milled Argyle Sample.

Utilizing the milling curve seen in Figure 5, an 80 % passing 20 µm fraction was generated for cyanide leaching characterization test work. Bottle roll cyanidation testing were conducted on this fraction to evaluate the leachability properties of Argyle material. These results and operating conditions are detailed in Table 8 and Table 9. A bottle roll was conducted at 33% solids utilizing a NaCN concentration of 2 g/L.

**Table 8
 Bottle Roll Testing Operating Conditions and Assays**

Leachate pH			Cons. (kg/t)		Meas. Head Grade	Calc. Head Grade	Residue Grade
Initial	Start	Final	CaO	NaCN	Au (g/t)	Au (g/t)	Au (g/t)
5.10	11.30	11.40	2.83	0.72	2.203	1.991	0.110

Table 9
Results from CN Bottle Roll Testing

Au Extracted (mg/L)				Au Extracted (mg/kg)				Au Extracted (%)			
2 hr.	6 hr.	24 hr.	48 hr.	2 hr.	6 hr.	24 hr.	48 hr.	2 hr.	6 hr.	24 hr.	48 hr.
0.73	0.90	0.92	0.94	1.46	1.80	1.84	1.88	73.4	90.5	92.5	94.5

As seen from Table 8 and Table 9, the Argyle feed material produced a high gold extraction value of 94.5 % when leached at a grind size of 80 % passing 20 μm . NaCN and CaO consumption was relatively low at 0.72 kg/t for NaCN and 2.83 kg/t for CaO. It was also noted that the kinetics were favorable as illustrated by Figure 6.

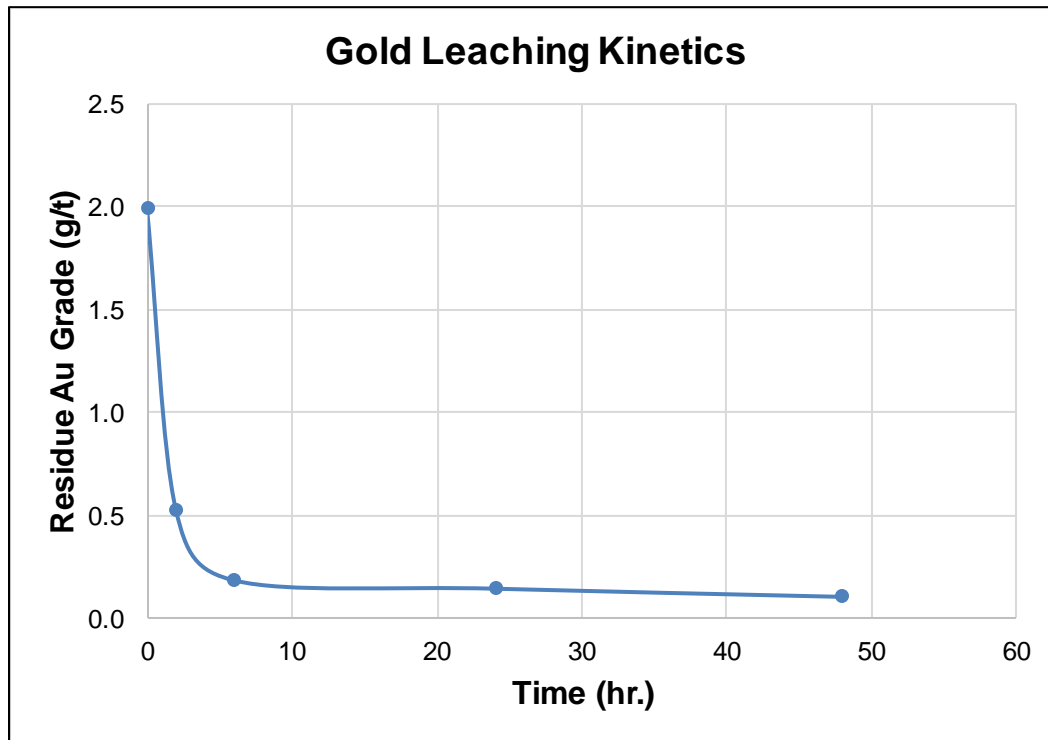

Figure 6: Gold Leaching Kinetics on Argyle Feed Material with P80 of 20 μm .

It was recommended that cyanidation testing on flotation concentrate also be conducted to confirm these positive results, noting that the S content would be significantly increased in a flotation concentrate.

The Rougher 1 flotation concentrates produced during this test program (see Table 4 and Table 6) were thus combined and homogenized to produce the flotation concentrate blend described in Table 10.

Table 10
Flotation Concentrate Blend Prepared

Sample ID	Mass (g)	Grade (g/t)
		Au
70% Passing 150µm Rghr 1 Conc	22.4	58.49
80% Passing 150µm Rghr 1 Conc	37.5	85.83
90% Passing 150µm Rghr 1 Conc	50.0	52.48
100% Passing 150µm Rghr 1 Conc	61.4	42.18
Test A Rghr 1 Conc	49.9	75.64
Test B Rghr 1 Conc	47.9	69.49
Test C Rghr 1 Conc	49.0	61.68
Test D Rghr 1 Conc	75.1	34.40
Calc. Head	393.2	57.10

The prepared blend outlined in Table 10 was subsequently prepared into the 80 % passing 20 µm size class and subjected to bottle roll cyanidation at a solids content of 36 %. A NaCN concentration of 2 g/L was utilized with operating conditions as given by Table 11 to produce the results of Table 12 and Figure 7.

Table 11
Flotation Concentrate Bottle Roll Testing Operating Conditions and Assays

Leachate pH			Cons. (kg/t)		Meas. Head Grade	Calc. Head Grade	Residue Grade
Initial	Start	Final	CaO	NaCN	Au (g/t)	Au (g/t)	Au (g/t)
7.30	11.20	11.20	1.13	2.96	60.187	58.264	6.882

Table 12
Results from CN Bottle Roll Testing on Flotation Concentrate

Au Extracted (mg/L)				Au Extracted (mg/kg)				Au Extracted (%)			
2 hr.	6 hr.	24 hr.	48 hr.	2 hr.	6 hr.	24 hr.	48 hr.	2 hr.	6 hr.	24 hr.	48 hr.
19.80	26.40	29.20	29.30	34.72	46.30	51.21	51.38	59.6	79.5	87.9	88.2

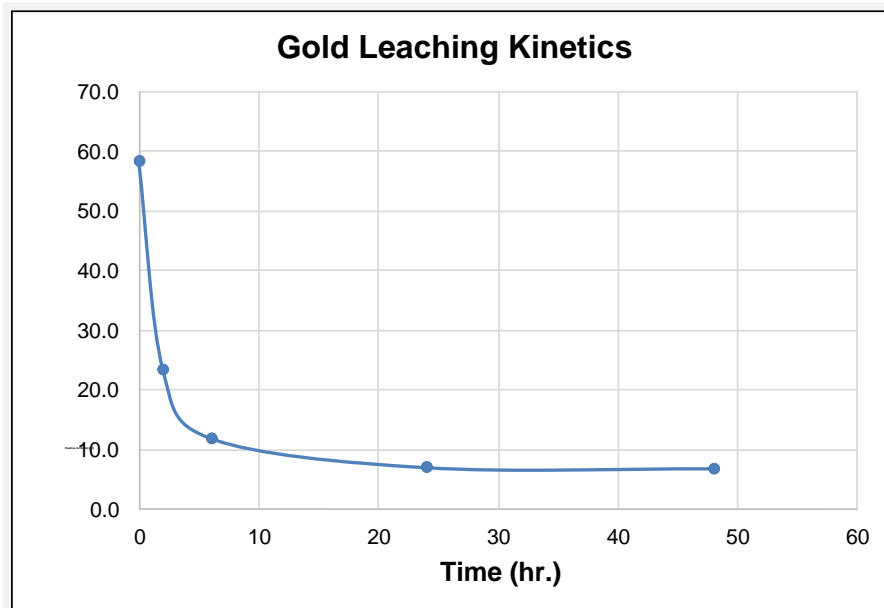

Figure 7: Gold Leaching Kinetics on Argyle Flotation Concentrate with P80 of 20 µm.

Table 11, Table 12 and Figure 7 indicated that the flotation kinetics were slower on the flotation concentrate as compared to on the whole ore (see Figure 6) and 88.2 % of the Au was extracted after 48 hours consuming 2.96 kg/t NaCN with 1.13 kg/t CaO. These results were considered positive, though it was noted that the final residue grade after cyanidation was still high at 6.88 g/t Au and further optimization test work is recommended. Further test work could include a grind investigation to evaluate the effect of grind size on final residue grade as well as an investigation of the effect of additional NaCN.

CONCLUSIONS AND RECOMMENDATIONS

Note that all results obtained were in good agreement with each other and showed that:

- The Argyle sample received was amenable to cyanidation at a grind size of 80 % passing 20 μm . An Au extraction value of 94.5 % was obtained with a relatively low NaCN consumption value (0.72 kg/t) at a NaCN concentration of 2 g/L.
- Flotation reagent scoping test work indicated that with 50 g/t Danafloat 233, a cumulative Au recovery value to the concentrate of 97.3 % could be attained at a grind size of 90 % passing 150 μm . With this reagent regime, a cumulative concentrate containing 40.42 g/t Au in 6.8 % of the mass was obtained.
- Scoping flotation test work at varying grind sizes showed that while the highest cumulative Au recovery of 96.7 % could be attained at 90 % passing 150 μm , the highest cumulative Au grade could be attained at 80 % passing 150 μm . At 80 % passing 150 μm the cumulative concentrate contained 63.98 g/t Au in 4.6 % of the mass with an Au recovery of 95.9 %.
- Grindability test work on the Argyle material is recommended to confirm the throughput that could be expected at the Pine Cove mill.
- Further scoping flotation test work at a grind size of 80 % passing 150 μm was recommended to evaluate the effect of reagents such as Danafloat 233 on flotation performance.
- Centrifugal gravity concentration test work indicated that an Au concentrate could be produced prior to flotation at a grind size of 100 % passing 425 μm . The gravity concentrate obtained 13.80 g/t Au in 8.0 % of the mass at a recovery of 48.9 %.
- Additional centrifugal gravity concentration test work at increased liberation is recommended on the Argyle feed material to evaluate the extent to which the Au recovery could be increased.
- Cyanidation test work on a combination of flotation concentrate fractions indicated that an Au extraction value of 88.2 % was obtained with a NaCN consumption value of 2.96 kg/t at a NaCN concentration of 2 g/L on this material. The lower extraction and higher consumption obtained as compared to the whole ore was potentially due to the higher S contents in the flotation concentrate material. The final residue grade was still high at 6.88 g/t Au.
- Further cyanidation test work on flotation concentrate material was thus recommended to increase extraction and decrease final residue grade. This test work could include an investigation in the effect of liberation and NaCN addition.
- The Argyle Prospect material responded well to the current Pine Cove Mine circuit.

APPENDIX

Detailed Results from Liberation Flotation Test Work

Table 13
Grind Size Flotation Mass Balance Results

% Passing 150µm	No.	Stream Name	Mass Dist. (%)	Grade	Distribution
				Au (g/t)	Au (%)
70	1	Feed	100.0	1.78	100.0
	2	Rghr 1 Conc.	2.6	58.49	86.0
	3	Rghr 1 Tails	97.4	0.26	14.0
	4	Rghr 2 Tails	95.8	0.15	8.3
	5	Scav Clnr Feed	1.6	6.60	5.7
	6	Scav Clnr Conc.	0.2	30.04	3.3
	7	Scav Clnr Tails	1.4	3.22	2.4
% Passing 150µm	No.	Stream Name	Mass Dist. (%)	Grade	Distribution
80	1	Feed	100.0	3.09	100.0
	2	Rghr 1 Conc.	3.4	85.83	93.8
	3	Rghr 1 Tails	96.6	0.20	6.2
	4	Rghr 2 Tails	95.4	0.13	4.1
	5	Scav Clnr Feed	1.3	5.20	2.1
	6	Scav Clnr Conc.	0.1	35.04	1.6
	7	Scav Clnr Tails	1.1	1.30	0.5
% Passing 150µm	No.	Stream Name	Mass Dist. (%)	Grade	Distribution
90	1	Feed	100.0	2.23	100.0
	2	Rghr 1 Conc.	4.0	52.48	94.2
	3	Rghr 1 Tails	96.0	0.14	5.8
	4	Rghr 2 Tails	93.7	0.08	3.3
	5	Scav Clnr Feed	2.3	2.45	2.5
	6	Scav Clnr Conc.	0.3	12.97	1.8
	7	Scav Clnr Tails	2.0	0.82	0.7
% Passing 150µm	No.	Stream Name	Mass Dist. (%)	Grade	Distribution
100	1	Feed	100.0	2.03	100.0
	2	Rghr 1 Conc.	4.6	42.18	94.9
	3	Rghr 1 Tails	95.4	0.11	5.1
	4	Rghr 2 Tails	94.0	0.07	3.5
	5	Scav Clnr Feed	1.4	2.41	1.7
	6	Scav Clnr Conc.	0.2	12.28	1.1
	7	Scav Clnr Tails	1.2	0.91	0.5

Table 14
Size Flotation Discrete Rougher 1 Results

% Passing 150µm	Stream	Mass (%)	Grade	Distribution
			Au (g/t)	Au (%)
70	Concentrate	2.6	58.49	86.0
	Tailings	97.4	0.26	14.0
	Head	100.0	1.78	100.0
80	Concentrate	3.4	85.83	93.8
	Tailings	96.6	0.20	6.2
	Head	100.0	3.09	100.0
90	Concentrate	4.0	52.48	94.2
	Tailings	96.0	0.14	5.8
	Head	100.0	2.23	100.0
100	Concentrate	4.6	42.18	94.9
	Tailings	95.4	0.11	5.1
	Head	100.0	2.03	100.0

Table 15
Grind Size Flotation Discrete Rougher 2 Results

% Passing 150µm	Stream	Mass (%)	Grade	Distribution
			Au (g/t)	Au (%)
70	Concentrate	1.6	6.60	40.9
	Tailings	98.4	0.15	59.1
	Head	100.0	0.26	100.0
80	Concentrate	1.3	5.20	34.1
	Tailings	98.7	0.13	65.9
	Head	100.0	0.20	100.0
90	Concentrate	2.4	2.45	43.4
	Tailings	97.6	0.08	56.6
	Head	100.0	0.14	100.0
100	Concentrate	1.5	2.41	32.5
	Tailings	98.5	0.07	67.5
	Head	100.0	0.11	100.0

Table 16
Grind Size Flotation Discrete Scavenger Cleaner Results

% Passing 150µm	Stream	Mass (%)	Grade	Distribution
			Au (g/t)	Au (%)
70	Concentrate	12.6	30.04	57.3
	Tailings	87.4	3.22	42.7
	Head	100.0	6.60	100.0
80	Concentrate	11.6	35.04	77.9
	Tailings	88.4	1.30	22.1
	Head	100.0	5.20	100.0
90	Concentrate	13.4	12.97	71.0
	Tailings	86.6	0.82	29.0
	Head	100.0	2.45	100.0
100	Concentrate	13.2	12.28	67.2
	Tailings	86.8	0.91	32.8
	Head	100.0	2.41	100.0

Detailed Results from Flotation Reagent Scoping Test Work

Table 17
Flotation Reagent Scoping Mass Balance Results

Condition Test ID	No.	Stream Name	Mass Dist. (%)	Grade	Distribution
				Au (g/t)	Au (%)
A	1	Feed	100.0	3.21	100.0
	2	Rghr 1 Conc.	4.0	75.64	93.9
	3	Rghr 1 Tails	96.0	0.21	6.1
	4	Rghr 2 Tails	93.9	0.10	3.0
	5	Scav Clnr Feed	2.1	4.72	3.1
	6	Scav Clnr Conc.	0.2	37.50	2.9
	7	Scav Clnr Tails	1.9	0.50	0.3
Condition Test ID	No.	Stream Name	Mass Dist. (%)	Grade	Distribution
B	1	Feed	100.0	2.81	100.0
	2	Rghr 1 Conc.	3.9	69.49	96.0
	3	Rghr 1 Tails	96.1	0.12	4.0
	4	Rghr 2 Tails	93.2	0.08	2.7
	5	Scav Clnr Feed	2.9	1.31	1.3
	6	Scav Clnr Conc.	0.4	7.60	1.0
	7	Scav Clnr Tails	2.5	0.44	0.4
Condition Test ID	No.	Stream Name	Mass Dist. (%)	Grade	Distribution
C	1	Feed	100.0	2.57	100.0
	2	Rghr 1 Conc.	3.9	61.68	94.7
	3	Rghr 1 Tails	96.1	0.14	5.3
	4	Rghr 2 Tails	94.1	0.11	4.1
	5	Scav Clnr Feed	1.9	1.61	1.2
	6	Scav Clnr Conc.	0.2	10.03	0.8
	7	Scav Clnr Tails	1.7	0.59	0.4
Condition Test ID	No.	Stream Name	Mass Dist. (%)	Grade	Distribution
D	1	Feed	100.0	1.92	100.0
	2	Rghr 1 Conc.	5.3	34.40	94.3
	3	Rghr 1 Tails	94.7	0.12	5.7
	4	Rghr 2 Tails	92.1	0.08	3.8
	5	Scav Clnr Feed	2.6	1.36	1.9
	6	Scav Clnr Conc.	0.3	8.33	1.4
	7	Scav Clnr Tails	2.3	0.37	0.5

Table 18
Flotation Reagent Scoping Discrete Rougher 1 Results

Condition Test ID	Stream	Mass (%)	Grade	Distribution
			Au (g/t)	Au (%)
A	Concentrate	4.0	75.64	93.9
	Tailings	96.0	0.21	6.1
	Head	100.0	3.21	100.0
B	Concentrate	3.9	69.49	96.0
	Tailings	96.1	0.12	4.0
	Head	100.0	2.81	100.0
C	Concentrate	3.9	61.68	94.7
	Tailings	96.1	0.14	5.3
	Head	100.0	2.57	100.0
D	Concentrate	5.3	34.40	94.3
	Tailings	94.7	0.12	5.7
	Head	100.0	1.92	100.0

Table 19
Flotation Reagent Scoping Discrete Rougher 2 Results

Condition Test ID	Stream	Mass (%)	Grade	Distribution
			Au (g/t)	Au (%)
A	Concentrate	2.2	4.72	51.2
	Tailings	97.8	0.10	48.8
	Head	100.0	0.21	100.0
B	Concentrate	3.0	1.31	33.7
	Tailings	97.0	0.08	66.3
	Head	100.0	0.12	100.0
C	Concentrate	2.0	1.61	22.4
	Tailings	98.0	0.11	77.6
	Head	100.0	0.14	100.0
D	Concentrate	2.8	1.36	32.6
	Tailings	97.2	0.08	67.4
	Head	100.0	0.12	100.0

Table 20
Flotation Reagent Scoping Discrete Scavenger Cleaner Results

Condition Test ID	Stream	Mass (%)	Grade	Distribution
			Au (g/t)	Au (%)
A	Concentrate	11.4	37.50	90.7
	Tailings	88.6	0.50	9.3
	Head	100.0	4.72	100.0
B	Concentrate	12.3	7.60	70.9
	Tailings	87.7	0.44	29.1
	Head	100.0	1.31	100.0
C	Concentrate	10.7	10.03	67.0
	Tailings	89.3	0.59	33.0
	Head	100.0	1.61	100.0
D	Concentrate	12.4	8.33	75.8
	Tailings	87.6	0.37	24.2
	Head	100.0	1.36	100.0

Appendix K

Pine Cove Acid Rock Drainage (ARD) Results

PRELIMINARY REPORT

Phase I and II - Metal
Leaching and Acid Rock
Drainage Characterization
Pine Cove Deposit, NL

ANACONDA MINING INC.

REPORT NO. 1021014



REPORT NO. 1021014

PRELIMINARY REPORT TO **Anaconda Mining Inc.**
P.O. Box 238
Baie Verte, NL A0K 1B0

ON **Preliminary Report**
Phase I and II - Metal Leaching and Acid
Rock Drainage Characterization
Pine Cove Deposit, NL

June 12, 2007

Jacques Whitford
607 Torbay Road
St. John's, NL,
A1A 4Y6

Phone: 709-576-1458
Fax: 709-576-2126

www.jacqueswhitford.com



Table of Contents

1.0 INTRODUCTION.....	1
1.1 Sampling and Analysis Plan - Phases I & II.....	1
1.2 Geological and Mineralogical Background.....	2
2.0 SPATIAL ANALYSIS AND SAMPLE SELECTION	2
3.0 STATIC ML/ARD TEST WORK	4
3.1 Acid:Base Accounting	4
3.2 Mineralogical Analysis.....	4
3.3 Analysis for Soluble Constituents	4
4.0 CONCLUSIONS AND RECOMMENDATIONS	11
5.0 CLOSURE	11

List of Tables

Table 3-1	ABA Results for Waste Rock Samples.....	5
Table 3-2	ABA Results for Low Grade Ore Samples.....	6
Table 3-3	ABA Results for High Grade Ore Samples.....	7
Table 3-4	Whole Rock Major Element Analysis by XRF (Waste Rock Samples).....	8
Table 3-5	Multi-Element Trace Analysis by ICP (Low and High Grade Ore Samples).....	9
Table 3-6	Solubility (Shake flask) Analysis	10

List of Appendices

- APPENDIX A Laboratory Analysis Reports – ABA
- APPENDIX B Laboratory Analysis Reports – Whole Rock Analysis by XRF
- APPENDIX C Laboratory Analysis Reports – Bulk Metal Analysis by ICP
- APPENDIX D Laboratory Analysis Reports – Solubility

1.0 INTRODUCTION

The geological materials to be excavated, exposed and processed during mining of the Pine Cove Deposit will have varying potential for metal leaching and production of acidic drainage. Jacques Whitford has been retained by Anaconda Mining Inc. to implement a laboratory testing program for metal leaching and acid rock drainage (ML/ARD) to provide input into prediction of water chemistry for the various mine components.

This document provides the preliminary results of the Phase I and II components of the ML/ARD Sampling and Analysis Plan submitted on November 2, 2006. Static test work is currently ongoing and additional results will be available to supplement the data provided herein, as described further in Section 4 of this report.

1.1 Sampling and Analysis Plan - Phases I & II

The following subsections describe the proposed methodology for review and implementation of the static ML/ARD test work for the Pine Cove Project as previously presented in the ML/ARD Sampling and Analysis Plan (November 2, 2006).

Phase I – ARD Data Review

Preliminary geological characterization and static tests were conducted as part of the Feasibility Study and Development Plan work completed to date. The results of this work will be reviewed with all current geological and mine planning information to revise or refine the classification of geological and waste units (as necessary), and determine the requirement for additional static testing.

The requirement for additional static tests will be primarily determined by:

- spatial analysis of the tests conducted to date;
- review of available sources and quantity of material for testing;
- additional review of the classification of geological units base on the preliminary test results; and
- review of existing weathering, exposure and drainage data in the Pine Cove Deposit area.

Potential sources for rock material for static testing include exploration rock core, exposed rock at historical bulk sample locations and tailings from pilot scale metallurgical testing. Potential weathering, exposure and drainage data at the Pine Cove Deposit area (exposed rock at bulk sample locations) and nearby mine sites, including the Stog'er Tight site, will also be reviewed.

Phase II – Static Tests

Phase II of the ML/ARD sampling and analysis program will include the completion and interpretation of the static tests as determined to be required by the Phase I assessment. Static testing will include:

- mineralogical examination;
- elemental analysis (whole-rock, trace, and soluble); and



- acid-base accounting (ABA).

Based on the results of all static testing completed a review of the geological characterization and waste management concepts will be completed. A summary of all available information, test results, and data analysis will be compiled and recommendations for kinetic testing will be provided to Department of Natural Resources.

1.2 Geological and Mineralogical Background

Gold mineralization on the Pine Cove Property is hosted in the Point Rousse Complex, a structurally disrupted ophiolite that is thrust southward over the Pacquet Harbour Group along the Scrape Pond Thrust. The Point Rousse Complex consists of tuffs and volcanic flows intruded by gabbro and diabase, and is generally pervasively chloritized and iron-carbonatized. Near the base of the thrust sheet the units undergo intense deformation, forming highly crenulated and contorted quartz and/or carbonate-chlorite schists. The structurally underlying Pacquet Harbour Group is composed of amphibolitized intermediate to mafic volcanics. The Scrape Thrust, which splays off the north-northeast trending Baie Verte Line to the south, follows a pronounced arcuate trend, swinging from east to southeast, as it passes through and beyond the Pine Cove Deposit area, its configuration conforming to the trace of Baie Verte Flexure.

The Pine Cove Deposit consists of several stacked mineralized lenses (e.g. Lightning Zone, Thunder Zone) in the hanging wall of the northward-dipping Scrape Thrust which locally was observed to have thin units of ultramafic and granitoid rocks along it in the Pine Cove area. Although approximately parallel to the thrust, the mineralized zones at Pine Cove are also broadly stratabound within a northward dipping sequence of coarse and fine-grained mafic rocks which contrast with highly cleaved amphibolitic rocks in the footwall of the thrust. The host stratigraphy at Pine Cove is similar to that at the adjacent Stog'er Tight deposit (Kirkwood and Dubé, 1992) where the coarse-grained mafic rocks are likely original gabbro and the finer-grained rocks are likely basalt flows punctuated by minor metasedimentary rocks in a northward dipping panel. The tabular mineralized zones are irregular lenses of ribbon quartz veins and altered sulfidic rock enveloped by outer chlorite-magnetite, medial sericite-carbonate and inner albite alteration. Leucoxene, a common product of carbonatization of Ti-bearing oxide minerals was noted to be abundant in the Pine Cove drill core.

Additional geological background can be found in the Pine Cove Deposit Development Plan (Revised June, 2006).

2.0 SPATIAL ANALYSIS AND SAMPLE SELECTION

In order to select the appropriate number and distribution of samples for static ML/ARD test work, a detailed review of following project information was completed:

- results of static test work previously completed,
- location and distribution of exploration boreholes,
- availability of rock core samples from the boreholes,
- geological material type, handling and storage characteristics at the proposed mine site, and
- geological units and variation within and surrounding the proposed open pit area.

The spatial analysis and selection of samples included a full assessment of the borehole data and planned pit geometry. Raw borehole data was analyzed based on the open pit geometry and bench plans, thereby permitting classification (waste, low grade ore or high grade ore) and selection of rock core samples over the actual bench interval as they would be mined during operations. The rock core sample lengths, as shown, are often longer than the planned bench height of 6 m as they are corrected for borehole dip.

Previous ML/ARD test work was conducted on samples of various length, however were primarily representative of selected geological units only. The current suit of samples were primarily selected and sampled over the entire bench height of 6 m as recommended in Price, 1997. However, in order to ensure comparable test results with previous test work and ensure that all geological units were tested, several samples were selected and tested to represent the geological unit only and not the entire mine bench. The depth and length (interval) of each sample is presented in the tabulated test results.

Waste Rock

Based on the assessment of the open pit geometry and available rock core, approximately 105 samples (each representing a full 6 m open pit bench) were reviewed. Detailed assessment of previous test work, geological and spatial data indicated that approximately 80 statistically representative samples were available for test work. From this sample set, 26 samples were selected to supplement the 20 samples previously tested. To date, 46 samples have been selected for static test work representing approximately 45% of the waste rock core samples currently available for testing.

Low Grade Ore

The classification of "Low Grade Ore" (LGO) is anticipated to vary over the life of the mine and will be based on gold prices and mining/milling costs. For the purpose of this assessment, LGO is considered to be excavated mine material with an approximate average bench grading of between 0.25 and 0.5 grams per tonne of gold.

Based on the assessment of the open pit geometry and available rock core, approximately 11 samples (each representing a full 6 m open pit bench) were reviewed. Detailed assessment of previous test work, geological and spatial data indicated that approximately 8 statistically representative samples were available for test work. All LGO samples were selected for static test work, representing 100% of the available LGO samples. To date, 19 samples have been selected for static test work representing 100% of the waste rock core samples currently available for testing.

High Grade Ore

Based on the assessment of the open pit geometry and available rock core, approximately 29 samples (each representing a full 6 m open pit bench) were reviewed. Detailed assessment of previous test work, geological and spatial data indicated that approximately 22 statistically representative samples were available for test work. From this sample set, 22 samples were selected to supplement the 5 samples previously tested. Therefore, to date 27 samples have been selected for static test work representing approximately 100% of the geological and spatial variation of the HGO material and 80% of the total number of available HGO samples available for testing.



3.0 STATIC ML/ARD TEST WORK

3.1 Acid:Base Accounting

The results of all Acid:Base Accounting (ABA) test work are summarized in Tables 3-1 to 3-3 for Waste Rock, LGO, and HGO, respectively. The following comments are provided for each material type, based on these results.

Waste Rock

The NP/AP ratios for the waste rock samples tested range from 11 to 676 over 46 samples. Based on the static ML/ARD test results available to date, it is not anticipated that the waste rock will be acid generating.

Low Grade Ore

The NP/AP ratios for the LGO samples tested range from 9 to 815 over 19 samples. Based on the static ML/ARD test results available to date, it is not anticipated that the LGO will be acid generating.

High Grade Ore

The NP/AP ratios for the HGO samples tested range from 1.3 to 81.3 over 27 samples. Only five samples have indicated NP/AP ratios of less than 4 and are classified within the possibly, to low possibility of ARD generating potential categories according to Price, 1997 (Table 8-4).

It is important to note that each of these five samples represent a small sampling interval of only HGO (vein) and are not representative of the geological material that will be mined (and mixed) over the bench height in which these samples will occur.

Additional static test work is ongoing which is intended to provide additional insight into the ML/ARD characteristics of HGO materials (future tailings). It is anticipated that kinetic test work will also be required to confirm the ML/ARD potential of these materials.

3.2 Mineralogical Analysis

Whole rock major element analysis by XRF (borate fusion) was completed on 19 waste rock samples and these results are shown in Table 3-4. The results show typical element composition for these types of geological units.

Bulk metals analysis was completed on 24 Low and High Grade Ore samples by strong acid digestion (4 Acid) for trace metals (ICP-AES and ICP-MS). These results are shown in Table 3-5 and show typical element composition.

3.3 Analysis for Soluble Constituents

Solubility tests (shake flask method) were completed on 12 samples of HGO, LGO and Waste Rock and the results are presented in Table 3-6. Note that only 2 tests were completed on LGO and Waste Rock samples and are primarily intended for comparison with the results for HGO samples.



Table 3-1: ABA Results for Waste Rock Samples

DDH	Sample ID	Drill Depth		Interval (m)	Waste Type	Rock Type	Paste pH (units)	Total Sulphur (%)	Acid Leachable SO4-S (%)	Sulphide-S (%)	Total Carbon (%)	Carbonate (%)	NP (t CaCO3/1000t)	AP (t CaCO3/1000t)	Net NP (t CaCO3/1000t)	NP/AP Ratio
		To (m)	From (m)													
PC-04-126	55610-10	16.0	16.5	0.5	WR	SC	8.4	0.448	< 0.005	0.448	n/a	n/a	150	14.0	136	10.7
PC-04-123	55610-05	25.0	25.5	0.5	WR	MV	8.5	0.213	< 0.005	0.213	n/a	n/a	72.6	6.7	65.9	10.9
PC-05-166	AB-1	50.5	51.0	0.5	WR	MV	9.28	0.22	0.15	< 0.4	1.12	5.12	107	4.7	102	22.8
PC-04-131	55610-03	23.0	23.5	0.5	WR	MV	8.4	0.225	< 0.005	0.225	n/a	n/a	183	7.0	176	26.1
PC-04-124	63402	26.5	33.5	7.0	WR	MV	9.25	0.250	0.06	0.19	1.25	5.76	182	5.9	177	30.8
PC-04-131	63413	18.5	25.4	6.9	WR	MV	9.15	0.303	0.09	0.22	1.51	6.92	228	6.9	221	33.0
PC-05-172	AB-17	5.0	6.0	1.0	WR	MV	9.17	0.17	0.13	< 0.4	2.30	10.6	189	4.1	185	46.1
PC-05-163	AB-23	18.0	19.5	1.5	WR	MV	9.10	0.13	0.10	< 0.4	1.88	8.57	165	3.1	162	53.2
PC-05-173	63451	15.0	22.0	7.0	WR	MV	9.24	0.162	0.05	0.12	1.58	7.22	198	3.6	194	54.7
PC-04-125	63403	15.0	22.0	7.0	WR	MV	9.34	0.160	0.05	0.11	1.36	6.16	187	3.4	183	54.9
PC-05-165	63444	28.7	31.1	2.4	WR	GB	9.18	0.161	0.06	0.10	1.59	7.38	175	3.1	171	55.7
PC-04-135	63415	3.0	9.2	6.2	WR	SC	9.30	0.231	0.10	0.13	1.92	9.05	247	4.2	243	59.2
PC-05-168	63448	11.7	16.5	4.8	WR	MV	9.62	0.126	0.03	0.09	1.50	6.89	179	2.8	176	62.9
PC-04-130	63411	16.3	23.2	6.9	WR	MV	9.23	0.143	0.02	0.12	2.07	9.88	251	3.8	247	65.8
PC-04-136	63421	37.8	45.5	7.7	WR	MV	9.21	0.170	0.06	0.11	1.94	8.91	231	3.5	228	65.9
PC-05-168	AB-14	51.0	52.1	1.1	WR	MV	9.37	0.04	0.03	< 0.4	0.65	2.82	69.2	0.94	68.3	73.6
PC-05-175	63455	11.0	17.2	6.2	WR	MV	9.23	0.182	0.07	0.11	2.03	9.78	256	3.4	252	74.5
PC-04-142	63438	37.3	44.3	7.0	WR	MV	9.55	0.118	0.03	0.09	1.93	9.09	205	2.7	202	74.7
PC-04-131	55610-02	16.5	17.0	0.5	WR	SC	8.9	0.016	< 0.005	0.016	n/a	n/a	38.6	0.5	38.1	77.1
PC-05-164	63443	8.4	15.5	7.1	WR	MV	9.36	0.124	0.06	0.06	0.916	4.12	153	1.9	151	82.7
PC-04-135	63418	44.0	50.8	6.8	WR	SC	9.35	0.125	0.05	0.08	2.04	9.80	238	2.5	235	94.8
PC-05-162	AB-22	22.0	23.2	1.2	WR	MV	9.17	0.07	0.05	< 0.4	1.73	7.88	155	1.6	153	96.9
PC-04-142	63440	65.3	72.3	7.0	WR	SC	9.29	0.090	0.02	0.07	1.77	8.23	202	2.1	200	97.4
PC-05-163	AB-24	33.0	33.5	0.5	WR	MV	9.24	0.05	0.04	< 0.4	1.31	6.01	118	1.2	117	98.3
PC-04-137	63423	11.7	19.4	7.7	WR	SC	9.28	0.081	0.01	0.07	1.78	8.63	228	2.2	226	105
PC-04-136	63420	6.1	11.3	5.2	WR	GB	9.22	0.099	0.04	0.06	1.48	6.53	212	1.9	210	113
PC-05-172	AB-18	32.0	33.0	1.0	WR	MV	9.23	0.05	0.05	< 0.4	2.08	9.80	185	1.6	183	116
PC-04-126	55610-12	50.5	51.0	0.5	WR	SC	8.7	0.040	< 0.005	0.040	n/a	n/a	159	1.3	158	128
PC-05-166	AB-2	14.7	15.3	0.6	WR	MV	9.40	0.07	0.03	< 0.4	1.33	6.13	120	0.94	119	128
PC-04-135	63417	23.0	30.0	7.0	WR	GB	9.37	0.105	0.04	0.06	1.79	8.42	250	1.9	248	130
PC-04-133	63414	13.7	18.3	4.6	WR	MV	9.30	0.084	0.02	0.06	2.01	9.59	258	1.9	256	136
PC-05-167	63446	63.4	71.0	7.6	WR	MV	9.29	0.062	0.03	0.03	1.86	8.84	200	1.0	199	193
PC-04-141	63429	14.0	21.2	7.2	WR	GB	9.32	0.064	0.03	0.03	1.31	6.03	189	0.94	188	201
PC-04-142	63435	23.4	30.3	6.9	WR	GB	9.52	0.045	0.01	0.03	1.71	8.09	203	0.94	202	216
PC-05-162	AB-20	8.0	10.0	2.0	WR	MV	9.19	0.04	0.02	< 0.4	1.59	7.24	141	0.62	140	227
PC-04-126	63405	3.4	10.0	6.6	WR	SC	9.24	0.033	< 0.01	0.03	2.12	10.2	225	0.94	224	239
PC-04-140	63427	74.0	80.8	6.8	WR	GB	9.41	0.094	0.06	0.03	1.87	8.85	250	0.9	249	267
PC-05-167	AB-11	85.0	85.6	0.6	WR	MV	9.36	0.02	< 0.01	< 0.4	0.92	4.22	90.0	0.31	89.7	290
PC-04-141	63433	78.0	85.0	7.0	WR	MV	9.45	0.034	0.01	0.02	2.02	9.67	225	0.62	225	363
PC-04-140	63425	11.5	18.5	7.0	WR	MV	9.60	0.024	< 0.01	0.02	2.32	11.4	235	0.62	234	379
PC-05-168	AB-13	26.0	26.6	0.6	WR	MV	9.42	0.02	< 0.01	< 0.4	1.42	6.46	138	0.31	138	445
PC-05-167	AB-7	18.0	18.6	0.6	WR	MV	9.51	0.03	0.01	< 0.4	1.97	9.14	160	0.31	160	516
PC-05-167	AB-8	9.0	9.7	0.7	WR	MV	9.73	< 0.01	< 0.01	< 0.4	1.83	8.31	167	0.31	167	539
PC-05-162	AB-21	13.0	14.2	1.2	WR	MV	9.43	0.01	< 0.01	< 0.4	2.25	10.5	198	0.31	198	639
PC-04-135	63419	64.5	71.6	7.1	WR	SC	9.27	0.014	< 0.01	0.01	1.44	6.76	208	0.31	208	671
PC-04-127	55610-09	49.5	50.0	0.5	WR	SC	8.7	0.006	< 0.005	0.006	n/a	n/a	127	0.2	127	676

Table 3-2: ABA Results for Low Grade Ore Samples

DDH	Sample ID	Drill Depth		Interval (m)	Waste Type	Rock Type	Paste pH (units)	Total Sulphur (%)	Acid Leachable SO4-S (%)	Sulphide-S (%)	Total Carbon (%)	Carbonate (%)	NP (t CaCO3/1000t)	AP (t CaCO3/1000t)	Net NP (t CaCO3/1000t)	NP/AP Ratio
		To (m)	From (m)													
PC-05-172	AB-16	57.0	58.0	1.0	LGO	MV	9.18	0.54	0.44	< 0.4	1.39	6.18	120	13.8	106	8.7
PC-05-175	AB-19	11.0	13.0	2.0	LGO	MV	9.16	0.32	0.23	< 0.4	1.87	8.47	68.9	7.2	61.7	9.6
PC-05-168	AB-12	61.0	62.0	1.0	LGO	MV	9.29	0.35	0.29	< 0.4	1.13	5.15	108	9.1	98.9	11.9
PC-04-123	55610-06	51.0	51.5	0.5	LGO	MV	8.5	0.309	< 0.005	0.309	n/a	n/a	133	9.7	124	13.8
PC-05-167	AB-10	119.0	120.5	1.5	LGO	MV	9.12	0.22	0.17	< 0.4	1.48	6.43	111	5.3	106	20.9
PC-05-166	AB-5	86.8	88.1	1.3	LGO	MV	9.25	0.20	0.16	< 0.4	1.43	6.55	129	5.0	124	25.8
PC-04-123	55610-04	9.0	9.5	0.5	LGO	MV	8.5	0.130	< 0.005	0.130	n/a	n/a	133	4.1	129	32.7
PC-05-166	AB-4	83.8	85.2	1.4	LGO	MV	9.29	0.07	0.05	< 0.4	0.46	1.98	52.5	1.6	50.9	32.8
PC-05-172	63449	9.2	16.0	6.8	LGO	MV	9.09	0.214	0.03	0.18	1.67	7.74	236	5.7	231	41.6
PC-04-131	55610-01A	4.5	5.0	0.5	LGO	SC	8.5	0.113	< 0.005	0.113	n/a	n/a	152	3.5	148	42.9
PC-04-142	63436	30.3	37.3	7.0	LGO	TF	9.37	0.184	0.06	0.13	1.74	8.02	202	4.0	198	51.1
PC-05-162	63441	15.5	22.0	6.5	LGO	MV	9.28	0.199	0.08	0.11	1.74	8.14	200	3.6	196	56.2
PC-05-174	63454	47.5	54.3	6.8	LGO	MV	9.15	0.213	0.08	0.13	1.80	8.55	251	4.0	247	62.6
PC-04-131	63412	4.5	11.8	7.3	LGO	SC	9.23	0.126	0.01	0.12	2.19	10.8	253	3.8	249	66.5
PC-04-127	55610-07	11.5	12.0	0.5	LGO	MV	8.5	0.027	< 0.005	0.027	n/a	n/a	72.7	0.8	71.9	86.2
PC-04-126	55610-11	30.0	30.5	0.5	LGO	SC	8.6	0.005	< 0.005	0.005	n/a	n/a	59.2	0.2	59.0	379
PC-05-166	63445	24.2	31.2	7.0	LGO	MV	9.67	0.015	0.02	< 0.01	1.59	7.58	170	0.31	170	549
PC-04-140	63426	18.3	25.3	7.0	LGO	MV	9.64	0.044	0.03	0.01	1.94	9.44	253	0.31	252	815

Table 3-3: ABA Results for High Grade Ore Samples

DDH	Sample ID	Drill Depth		Interval (m)	Waste Type	Rock Type	Paste pH (units)	Total Sulphur (%)	Acid Leachable SO4-S (%)	Sulphide-S (%)	Total Carbon (%)	Carbonate (%)	NP (t CaCO3/1000t)	AP (t CaCO3/1000t)	Net NP (t CaCO3/1000t)	NP/AP Ratio
		To (m)	From (m)													
PC-05-166	AB-3	85.5	86.5	1.0	HGO	MV	9.32	2.81	2.65	< 0.4	1.20	5.00	111	83	28	
PC-05-166	AB-6	168.0	169.0	1.0	HGO	MV	9.09	2.30	2.18	< 0.4	1.01	4.26	101	68	33	
PC-04-127	63408	2.7	7.0	4.3	HGO	MV/SC	9.08	3.92	0.26	3.66	2.09	8.94	238	114	123	2.1
PC-04-136	63422	45.8	46.7	0.9	HGO	SC	9.36	2.77	0.42	2.35	2.11	8.52	244	73	170	3.3
PC-05-167	AB-9	123.0	124.0	1.0	HGO	MV	9.27	0.95	0.83	< 0.4	1.18	5.01	102	26	76	3.9
PC-04-141	63432	63.5	70.5	7.0	HGO	MV	9.21	1.23	0.25	0.98	1.57	6.82	201	31	171	6.6
PC-04-142	63439	57.8	59.0	1.2	HGO	SC	9.10	1.11	0.27	0.85	1.41	6.09	202	27	176	7.6
PC-04-141	63430	31.6	32.6	1.0	HGO	GB	9.02	0.911	0.19	0.72	1.40	6.16	196	23	174	8.7
PC-05-172	63450	50.8	57.0	6.2	HGO	MV	9.07	1.06	0.23	0.83	2.09	9.62	227	26	201	8.8
PC-04-126	63406	18.2	26.0	7.8	HGO	SC	8.87	1.09	0.31	0.77	1.59	7.51	236	24	212	9.8
PC-05-163	63442	10.8	17.0	6.2	HGO	MV	9.12	0.809	0.15	0.66	1.94	8.98	206	21	185	9.9
PC-05-172	AB-15	18.0	19.0	1.0	HGO	MV	9.02	0.57	0.47	< 0.4	1.88	8.57	159	15	144	10.8
PC-05-174	63452	26.5	33.5	7.0	HGO	MV	9.24	0.802	0.23	0.57	1.77	8.07	246	18	228	13.7
PC-04-127	63409	15.5	24.0	8.5	HGO	SC	8.98	0.675	0.19	0.48	1.65	7.90	225	15	210	15.0
PC-05-174	63453	40.5	47.5	7.0	HGO	MV	9.03	0.664	0.16	0.50	1.47	6.66	238	16	222	15.1
PC-04-124	63401	6.0	12.5	6.5	HGO	MV	9.03	0.565	0.15	0.42	1.76	8.49	248	13	235	18.9
PC-04-137	63424	19.6	27.3	7.7	HGO	SC	9.15	0.478	0.09	0.39	1.66	7.62	247	12	235	20.4
PC-04-140	63428	81.0	87.9	6.9	HGO	GB	9.35	0.458	0.15	0.31	1.58	7.12	204	10	194	21.3
PC-04-125	63404	22.0	28.8	6.8	HGO	MV	9.29	0.398	0.13	0.27	1.59	7.23	188	8	180	22.6
PC-04-130	63410	9.2	16.2	7.0	HGO	MV	9.05	0.465	0.13	0.34	1.99	9.41	268	11	257	25.5
PC-04-126	63407	26.5	27.5	1.0	HGO	SC	8.99	0.280	0.06	0.22	1.01	4.60	205	7	198	29.7
PC-04-142	63434	16.3	23.3	7.0	HGO	SC	9.51	0.289	0.07	0.22	2.05	9.65	241	7	234	35.4
PC-04-142	63437	44.4	51.5	7.1	HGO	SC	9.11	0.381	0.20	0.18	1.48	7.08	202	6	197	36.1
PC-04-127	55610-08	24.0	24.5	0.5	HGO	SC	8.5	0.037	< 0.005	0.037	n/a	n/a	58	1	57	50.2
PC-05-167	63447	70.8	78.0	7.2	HGO	MV	9.38	0.172	0.05	0.12	1.92	8.76	207	4	203	54.3
PC-04-135	63416	9.2	16.0	6.8	HGO	SC	9.15	0.230	0.12	0.10	1.88	9.22	234	3	230	75.3
PC-04-141	63431	35.5	42.5	7.0	HGO	MV	9.36	0.138	0.07	0.07	1.36	6.21	179	2	177	81.3

Table 3-4: Whole Rock Major Element Analysis by XRF (Waste Rock Samples)

DDH	Sample ID	Drill Depth		Interval (m)	Waste Type	Rock Type	Elemental Concentrations										
		To (m)	From (m)				Si %	Al %	Fe %	Mg %	Ca %	Na %	K %	Ti %	P %	Mn %	Cr %
PC-04-124	63402	26.5	33.5	7.0	WR	MV	21.4	6.2	5.5	2.86	5.78	0.95	0.04	1.43	0.08	0.17	< .01
PC-04-125	63403	15.0	22.0	7.0	WR	MV	21.6	6.4	5.2	2.51	5.90	1.29	0.02	1.55	0.11	0.18	< .01
PC-04-126	63405	3.4	10.0	6.6	WR	SC	20.1	6.8	4.4	2.53	6.93	1.12	0.13	1.07	0.05	0.14	< .01
PC-04-130	63411	16.3	23.2	6.9	WR	MV	19.7	6.6	4.5	3.32	7.29	0.78	0.18	1.09	0.06	0.17	0.00
PC-04-131	63413	18.5	25.4	6.9	WR	MV	21.4	6.2	5.5	2.73	5.15	0.92	0.05	1.44	0.08	0.14	< .01
PC-04-135	63417	23.0	30.0	7.0	WR	GB	21.3	7.1	3.8	3.46	5.80	0.44	0.39	0.92	0.04	0.13	0.01
PC-04-135	63418	44.0	50.8	6.8	WR	SC	21.2	6.5	4.1	2.79	6.76	0.65	0.36	1.00	0.05	0.14	0.00
PC-04-136	63421	37.8	45.5	7.7	WR	MV	20.6	6.4	4.8	2.82	6.55	0.75	0.26	1.19	0.06	0.15	< .01
PC-04-137	63423	11.7	19.4	7.7	WR	SC	22.1	6.7	4.0	3.11	5.99	0.40	0.41	0.91	0.05	0.15	0.01
PC-04-140	63427	74.0	80.8	6.8	WR	GB	21.2	6.8	4.2	3.62	5.97	0.21	0.38	0.96	0.04	0.13	0.00
PC-04-141	63429	14.0	21.2	7.2	WR	GB	24.3	7.0	3.6	2.86	4.38	1.04	0.33	0.85	0.05	0.16	0.01
PC-04-141	63433	78.0	85.0	7.0	WR	MV	20.4	7.4	3.5	3.57	6.78	0.81	0.24	0.86	0.05	0.13	0.01
PC-04-142	63435	23.4	30.3	6.9	WR	GB	22.4	6.6	4.4	2.99	5.67	0.50	0.27	1.03	0.05	0.14	< .01
PC-04-142	63438	37.3	44.3	7.0	WR	MV	21.6	6.2	4.7	3.00	6.42	0.46	0.16	1.09	0.06	0.15	0.00
PC-04-142	63440	65.3	72.3	7.0	WR	SC	21.9	6.0	4.9	2.86	5.93	0.46	0.20	1.23	0.07	0.15	< .01
PC-05-164	63443	8.4	15.5	7.1	WR	MV	22.3	7.4	4.2	3.40	5.37	1.22	0.15	1.06	0.07	0.17	0.01
PC-05-165	63444	28.7	31.1	2.4	WR	GB	21.6	6.8	4.2	3.17	5.58	1.24	0.06	1.04	0.07	0.18	< .01
PC-05-168	63448	11.7	16.5	4.8	WR	MV	23.5	7.8	2.9	2.81	5.12	1.08	0.40	0.41	0.02	0.12	0.01
PC-05-175	63455	11.0	17.2	6.2	WR	MV	20.2	7.0	4.0	3.32	6.93	0.57	0.47	1.05	0.05	0.13	0.01
Average							21.5	6.7	4.3	3.04	6.02	0.78	0.24	1.06	0.06	0.15	0.01

Table 3-5: Multi-Element Trace Analysis by ICP (Low and High Grade Ore Samples)

DDH	Sample ID	Drill Depth		Interval (m)	Waste Type	Rock Type	Metals Concentrations																													
		To (m)	From (m)				Ag (g/t)	Al (g/t)	As (g/t)	Ba (g/t)	Be (g/t)	Bi (g/t)	Ca (g/t)	Cd (g/t)	Co (g/t)	Cr (g/t)	Cu (g/t)	Fe (g/t)	K (g/t)	Li (g/t)	Mg (g/t)	Mn (g/t)	Mo (g/t)	Na (g/t)	Ni (g/t)	Pb (g/t)	Sb (g/t)	Se (g/t)	Sn (g/t)	Sr (g/t)	Ti (g/t)	Tl (g/t)	U (g/t)	V (g/t)	Y (g/t)	Zn (g/t)
PC-04-131	63412	4.5	11.8	7.3	LGO	SC	0.16	69,000	< 2	70	0.65	0.07	70,000	0.8	30	76	40	84,000	7,000	18	31,000	1,400	0.9	13,000	31	4.7	0.1	< 1	0.3	230	220	0.1	0.14	270	15	88
PC-04-140	63426	18.3	25.3	7.0	LGO	MV	0.19	76,000	< 2	150	0.69	0.08	62,000	0.6	27	130	68	58,000	8,900	10	29,000	1,700	1.0	14,000	48	9.5	0.3	< 1	0.5	360	200	0.1	0.58	190	10.0	70
PC-04-142	63436	30.3	37.3	7.0	LGO	TF	0.20	68,000	< 2	72	0.73	0.14	53,000	0.8	40	45	50	90,000	4,500	22	33,000	1,400	1.4	16,000	20	5.6	0.2	< 1	0.3	250	210	< 0.1	0.23	260	13	100
PC-05-166	63445	24.2	31.2	7.0	LGO	MV	0.54	84,000	< 2	190	0.92	0.04	48,000	0.6	24	89	150	64,000	14,000	19	26,000	1,700	0.9	9,300	20	9.7	1.4	< 1	0.8	280	230	0.2	0.32	220	7.2	84
PC-05-172	63449	9.2	16.0	6.8	LGO	MV	0.20	60,000	< 2	82	0.75	0.15	51,000	1.3	33	34	28	98,000	10,000	15	28,000	1,500	2.2	5,300	12	6.1	0.2	< 1	0.6	230	350	0.2	0.13	380	17	120
PC-05-174	63454	47.5	54.3	6.8	LGO	MV	0.17	59,000	< 2	73	0.72	0.12	58,000	1.0	32	16	35	100,000	5,500	18	28,000	1,600	2.4	8,600	8	5.7	0.2	< 1	0.4	250	590	0.1	0.16	370	17	120
PC-04-124	63401	6.0	12.5	6.5	HGO	MV	0.50	68,000	87	70	< 0.007	0.35	59,000	0.7	32	28	66	87,000	5,500	< 3	28,000	1,200	2.6	20,000	27	9.8	1.1	< 1	0.5	240	620	0.1	0.19	240	20	96
PC-04-125	63404	22.0	28.8	6.8	HGO	MV	0.45	67,000	< 2	77	0.66	0.42	51,000	1.0	38	44	64	91,000	4,100	10	28,000	1,300	2.8	19,000	22	4.3	0.3	< 1	0.6	190	1700	0.1	0.27	300	19	93
PC-04-126	63406	18.2	26.0	7.8	HGO	SC	0.47	61,000	36	120	< 0.007	0.46	50,000	0.8	31	40	130	96,000	11,000	< 3	27,000	1,400	11.0	6,500	17	6.0	0.9	< 1	0.6	180	480	0.2	0.18	300	17	93
PC-04-128	63407	26.5	27.5	1.0	HGO	SC	0.27	71,000	2	75	0.70	0.21	38,000	1.1	35	48	60	110,000	11,000	19	36,000	1,400	2.0	7,700	14	6.9	0.3	< 1	0.8	140	2700	0.2	0.37	320	24	110
PC-04-130	63410	9.2	16.2	7.0	HGO	MV	0.36	61,000	< 2	76	0.79	0.29	64,000	1.1	40	23	55	110,000	7,400	19	31,000	1,800	2.7	4,500	15	7.4	0.6	< 1	0.5	240	560	0.1	0.20	370	20	130
PC-04-135	63416	9.2	16.0	6.8	HGO	SC	0.20	59,000	15	110	< 0.007	0.11	59,000	0.7	30	91	110	74,000	11,000	10	28,000	1,200	2.2	6,300	36	7.6	0.8	< 1	0.4	240	250	0.2	0.18	230	13	81
PC-04-137	63424	19.6	27.3	7.7	HGO	SC	0.44	61,000	< 2	75	0.63	0.43	54,000	0.9	32	71	54	85,000	7,600	10	28,000	1,400	2.1	10,000	21	7.5	0.4	< 1	0.5	210	520	0.1	0.20	270	18	84
PC-04-140	63428	81.0	87.9	6.9	HGO	GB	0.36	54,000	3	110	0.56	0.22	51,000	0.6	25	190	44	55,000	12,000	7	22,000	990	4.5	5,800	26	7.6	0.1	< 1	0.6	180	270	0.2	0.12	210	8.7	59
PC-04-141	63430	31.6	32.6	1.0	HGO	GB	0.70	62,000	< 2	100	0.62	0.67	48,000	0.9	35	72	92	90,000	10,000	7	27,000	1,700	2.3	8,200	22	7.9	0.4	< 1	0.4	180	300	0.1	0.21	290	12	96
PC-04-141	63432	63.5	70.5	7.0	HGO	MV	0.57	51,000	2	410	0.68	0.53	45,000	1.0	32	37	22	84,000	8,500	12	22,000	1,400	3.4	8,400	11	8.3	0.4	< 1	0.3	220	240	< 0.1	0.21	310	15	100
PC-04-142	63434	16.3	23.3	7.0	HGO	SC	0.29	62,000	< 2	89	0.77	0.26	63,000	0.8	38	110	61	78,000	7,000	19	30,000	1,500	2.1	9,000	29	10.0	0.2	< 1	0.4	350	140	< 0.1	0.18	260	12	82
PC-04-142	63437	44.4	51.5	7.1	HGO	SC	0.32	54,000	3	72	< 0.007	0.19	46,000	0.7	28	42	81	94,000	5,500	< 3	25,000	1,500	2.6	5,700	14	5.7	0.5	< 1	0.4	210	250	< 0.1	0.11	290	12	100
PC-04-142	63439	57.8	59.0	1.2	HGO	SC	0.53	67,000	< 2	77	0.61	0.54	50,000	0.9	36	35	27	120,000	6,500	11	32,000	1,500	4.1	12,000	10	5.5	0.2	< 1	0.3	200	330	< 0.1	0.21	360	14	120
PC-05-163	63442	10.8	17.0	6.2	HGO	MV	0.36	70,000	< 2	140	0.91	0.39	63,000	1.0	33	57	95	100,000	14,000	11	33,000	1,600	9.7	5,700	21	8.4	0.3	< 1	0.5	290	260	0.4	0.22	310	15	99
PC-05-167	63447	70.8	78.0	7.2	HGO	MV	0.18	66,000	2	97	0.84	0.08	61,000	0.9	38	180	54	82,000	11,000	17	33,000	1,500	1.1	11,000	170	7.2	0.3	< 1	0.6	300	630	0.2	0.15	290	17	97
PC-05-172	63450	50.8	57.0	6.2	HGO	MV	0.52	59,000	2	110	0.70	0.65	61,000	0.9	38	24	80	89,000	10,000	15	26,000	1,500	16.0	9,900	14	7.2	0.6	1	0.5	250	470	0.2	0.17	320	18	100
PC-05-174	63452	26.5	33.5	7.0	HGO	MV	0.41	60,000	3	130	0.64	0.95	57,000	1.0	30	87	34	73,000	12,000	8	28,000	1,400	78.0	8,200	38	10.0	0.2	< 1	0.5	240	320	0.2	0.27	230	14	82
PC-05-174	63453	40.5	47.5	7.0	HGO	MV	0.45	61,000	< 2	810	0.65	0.30	49,000	1.3	33	31	53	110,000	8,600	14	28,000	1,500	3.4	7,600	16	6.9	0.2	< 1	0.6	220	500	0.1	0.16	330	16	110
Average							0.37	63,833	15.50	141	0.71	0.32	54,625	0.9	33	64	65	88,417	8,858	13	28,625	1,462	6.7	9,654	28	7.3	0.4	1	0.5	237	514	0.16	0.22	288	15	96
Typical or Average Concentrations in Earth's Crust							0.04 - 0.1	"Major" 82,300	1 - 13	10 - 600	1 - 3	0.0085	"Major" 41,500	0.03 - 0.3	0.1 - 48	11 - 170	2 - 87	"Major" 56,300	20,850	20	23,300	50 - 1500	0.2 - 2.6	23,550	2 - 130	6 - 20	0.1 - 1	0.05	2.3	20 - 600	"Major" 5650	N/A	2.70	20 - 250	33	16 - 105

Table 3-6: Solubility (Shake Flask) Analysis

DDH	Sample ID	Drill Depth			Waste Type	Rock Type	Initial pH (units)	Final pH (units)	Metals Concentrations																														
		To (m)	From (m)	Interval (m)					Ag (mg/L)	Al (mg/L)	As (mg/L)	B (mg/L)	Be (mg/L)	Bi (mg/L)	Ca (mg/L)	Cd (mg/L)	Co (mg/L)	Cr (mg/L)	Cu (mg/L)	Fe (mg/L)	K (mg/L)	Li (mg/L)	Mg (mg/L)	Mn (mg/L)	Mo (mg/L)	Nb (mg/L)	Ni (mg/L)	Pb (mg/L)	Sb (mg/L)	Se (mg/L)	Sn (mg/L)	Sr (mg/L)	Ti (mg/L)	Tl (mg/L)	U (mg/L)	V (mg/L)	W (mg/L)	Y (mg/L)	Zn (mg/L)
PC-04-127	63408	2.7	7.0	4.3	HGO	MV/SC	9.39	8.71	< 0.0001	0.41	0.0002	0.021	< 0.0004	0.00004	22.5	< 0.00006	0.000030	< 0.0003	0.0003	< 0.01	4.97	< 0.002	3.14	0.005	0.00958	8.46	< 0.0007	< 0.00002	0.0010	0.003	0.0015	0.144	0.0008	< 0.0001	0.00003	0.00131	0.00178	0.00008	< 0.0003
PC-04-136	63422	45.8	46.7	0.9	HGO	SC	9.74	8.83	< 0.0001	0.39	0.0003	0.003	< 0.0004	< 0.00002	16.5	< 0.00006	0.000044	< 0.0003	0.0004	< 0.01	4.19	< 0.002	3.22	0.004	0.0128	9.03	0.0010	< 0.00002	0.0010	0.003	0.0013	0.147	0.0007	< 0.0001	0.00002	0.00122	0.00161	0.00007	0.0008
PC-04-141	63432	63.5	70.5	7.0	HGO	MV	9.67	9.13	< 0.0001	0.69	0.0003	0.007	< 0.0004	< 0.00002	8.11	< 0.00006	< 0.000007	< 0.0003	0.0002	< 0.01	6.02	< 0.002	1.51	0.002	0.00369	19.8	< 0.0007	< 0.00002	0.0010	< 0.001	0.0007	0.264	0.0003	< 0.0001	< 0.00002	0.00254	0.00164	0.000010	0.0003
PC-04-142	63439	57.8	59.0	1.2	HGO	SC	9.90	9.34	< 0.0001	1.19	0.0002	0.006	< 0.0004	< 0.00002	4.65	< 0.00006	< 0.000007	< 0.0003	0.0002	< 0.01	4.42	< 0.002	0.641	< 0.001	0.00182	29.9	< 0.0007	< 0.00002	0.0008	< 0.001	0.0005	0.0824	0.0003	< 0.0001	< 0.00002	0.00477	0.00282	0.000006	0.0074
PC-04-141	63430	31.6	32.6	1.0	HGO	GB	9.77	9.05	< 0.0001	0.58	< 0.0002	0.005	< 0.0004	< 0.00002	10.5	< 0.00006	< 0.000007	< 0.0003	0.0002	< 0.01	6.76	< 0.002	2.60	0.002	0.00172	6.11	< 0.0007	< 0.00002	0.0007	< 0.001	< 0.0003	0.197	< 0.0002	< 0.0001	< 0.00002	0.00250	0.00214	< 0.000005	< 0.0003
PC-05-172	63450	50.8	57.0	6.2	HGO	MV	9.44	8.96	< 0.0001	0.48	< 0.0002	0.008	< 0.0004	< 0.00002	13.4	< 0.00006	0.000010	< 0.0003	0.0002	< 0.01	8.24	< 0.002	2.88	0.002	0.00907	4.71	< 0.0007	< 0.00002	0.0006	< 0.001	0.0005	0.142	< 0.0002	< 0.0001	< 0.00002	0.00150	0.00123	0.000005	0.0004
PC-05-163	63442	10.8	17.0	6.2	HGO	MV	9.52	9.07	< 0.0001	0.11	0.0003	0.258	< 0.0004	< 0.00002	10.6	< 0.00006	< 0.000007	0.0010	0.0004	< 0.01	5.30	< 0.002	2.00	< 0.001	0.00715	11.2	< 0.0007	< 0.00002	0.0006	< 0.001	0.0004	0.113	< 0.0002	< 0.0001	< 0.00002	0.00180	0.00128	0.000021	0.0091
PC-04-124	63402	25.5	33.5	7.0	WR	MV	9.67	9.23	< 0.0001	0.66	< 0.0002	0.010	< 0.0004	< 0.00002	8.82	< 0.00006	0.000043	< 0.0003	0.0003	< 0.01	0.92	< 0.002	1.45	0.001	0.00111	6.74	< 0.0007	0.00008	0.0008	< 0.001	< 0.0003	0.0753	0.0002	< 0.0001	< 0.00002	0.00375	0.00105	0.000017	0.0007
PC-04-131	63413	18.5	25.4	6.9	WR	MV	9.63	9.13	< 0.0001	0.61	< 0.0002	0.004	< 0.0004	< 0.00002	10.2	< 0.00006	< 0.000007	< 0.0003	0.0002	< 0.01	1.59	< 0.002	1.89	0.002	0.00052	5.93	< 0.0007	< 0.00002	0.0005	< 0.001	< 0.0003	0.100	< 0.0002	< 0.0001	< 0.00002	0.00212	0.00058	0.000006	< 0.0003
PC-04-142	63434	16.3	23.3	7.0	HGO	SC	9.91	9.60	< 0.0001	1.22	0.0002	0.010	< 0.0004	< 0.00002	2.71	< 0.00006	< 0.000007	0.0004	0.0003	0.04	3.67	< 0.002	0.462	< 0.001	0.00136	34.0	< 0.0007	< 0.00002	0.0010	< 0.001	< 0.0003	0.0669	< 0.0002	< 0.0001	< 0.00002	0.00729	0.00124	< 0.000005	0.0005
PC-05-172	63449	9.2	18.0	8.8	LGO	MV	9.52	9.12	< 0.0001	0.65	< 0.0002	0.005	< 0.0004	< 0.00002	9.86	< 0.00006	< 0.000007	< 0.0003	0.0002	< 0.01	5.66	< 0.002	1.77	0.002	0.00139	3.92	< 0.0007	< 0.00002	0.0004	< 0.001	< 0.0003	0.0676	< 0.0002	< 0.0001	< 0.00002	0.00205	0.00105	< 0.000005	< 0.0003
PC-04-142	63436	30.3	37.3	7.0	LGO	TF	9.85	9.45	< 0.0001	0.95	< 0.0002	0.004	< 0.0004	< 0.00002	4.59	< 0.00006	< 0.000007	< 0.0003	0.0003	< 0.01	2.43	< 0.002	0.710	< 0.001	0.00120	15.9	< 0.0007	< 0.00002	0.0006	< 0.001	< 0.0003	0.0862	< 0.0002	< 0.0001	< 0.00002	0.00394	0.00074	< 0.000005	< 0.0003
Average							9.67	9.13	< 0.0001	0.66	0.0003	0.03	< 0.0004	0.00004	10.20	< 0.00006	0.000032	0.0007	0.0003	0.04	4.51	< 0.002	1.86	0.003	0.0044	12.97	0.0010	0.00008	0.0008	0.003	0.0008	0.12	0.0005	< 0.0001	0.00002	0.0029	0.0014	0.000010	0.0027

The results of the solubility tests show no significantly soluble minerals (short term). It should be noted that these results would only apply to limited situations and must be used in the context of all associated test results.

4.0 CONCLUSIONS AND RECOMMENDATIONS

At this time, static test work is ongoing. Additional test work is required on specific samples, representing the tailings materials that will be produced from the mill and leach circuit. A detailed analysis and report of all static test work and recommendations for kinetic test work will be provided once the results of all current work are available from the laboratory.

5.0 CLOSURE

We trust this preliminary report meets your present requirements. Should any additional information be required, please do not hesitate to contact our office at your convenience.

Yours truly,

JACQUES WHITFORD LIMITED

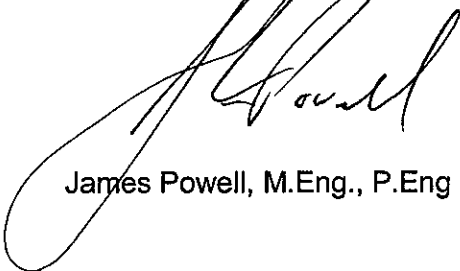

James Powell, M.Eng., P.Eng

APPENDIX A

Laboratory Analysis Reports – ABA



SGS Lakefield Research Limited
 P.O. Box 4300 - 185 Concession St.
 Lakefield - Ontario - K0L 2H0
 Phone: 705-652-2038 FAX: 705-652-6441

Tormin Resources

Attn : John Cook johncook@kos.net

3155 Hwy 27 RR#2
 Roslin, ON
 K0K 2Y0.

Phone: 613-477-1280
 Fax: 613-477-1248

Standard ABA (Price 1997) EPA600

Friday, March 09, 2007

Date Rec. : 14 February 2007
 LR Report: CA10190-FEB07

Copy: #1

CERTIFICATE OF ANALYSIS
Final Report

Analysis	3: Analysis Approval Date	4: Analysis Approval Time	5: PC-04-124 63402	6: PC-04-125 63403	7: PC-04-125 63404	8: PC-04-126 63405	9: PC-04-126 63407	10: PC-04-127 63408	11: PC-04-130 63410	12: PC-04-130 63411	13: PC-04-131 63412	14: PC-04-131 63413	15: PC-04-133 63414
Paste pH [units]	08-Mar-07	12:11	9.25	9.34	9.29	9.24	8.99	9.08	9.05	9.23	9.23	9.15	9.30
Fizz Rate [—]	08-Mar-07	12:11	4	4	4	4	4	4	4	4	4	4	4
Sample [weight(g)]	08-Mar-07	12:11	2.00	2.01	1.99	2.01	1.98	2.01	1.98	2.00	1.99	2.02	1.97
HCl added [mL]	08-Mar-07	12:11	40.00	40.00	40.00	40.00	40.00	40.00	40.00	40.00	40.00	40.00	40.00
HCl [Normality]	08-Mar-07	12:11	0.50	0.50	0.50	0.50	0.50	0.50	0.50	0.50	0.50	0.50	0.50
NaOH [Normality]	08-Mar-07	12:11	0.50	0.50	0.50	0.50	0.50	0.50	0.50	0.50	0.50	0.50	0.50
NaOH to [pH=7.0 mL]	08-Mar-07	12:11	25.40	25.00	25.00	21.90	23.75	20.90	18.80	19.90	19.90	21.60	19.65
Final pH [units]	08-Mar-07	12:11	1.28	1.41	1.42	1.45	1.44	1.59	1.63	1.47	1.48	1.47	1.44
NP [t CaCO3/1000 t]	08-Mar-07	12:11	182	187	188	225	205	238	268	251	253	228	258
AP [t CaCO3/1000 t]	06-Mar-07	09:29	5.9	3.4	8.4	0.94	6.9	114	10.5	3.8	3.8	6.9	1.9
Net NP [t CaCO3/1000 t]	08-Mar-07	12:11	177	183	180	224	198	123	257	247	249	221	256
NP/AP [ratio]	08-Mar-07	12:11	30.8	54.9	22.6	239	29.7	2.08	25.5	65.8	66.5	33.0	136
Total Sulphur [%]	27-Feb-07	15:23	0.250	0.160	0.398	0.033	0.280	3.92	0.465	0.143	0.126	0.303	0.084
Acid Leachable SO4-S [%]	02-Mar-07	07:36	0.06	0.05	0.13	< 0.01	0.06	0.26	0.13	0.02	0.01	0.09	0.02
Sulphide-S [%]	02-Mar-07	07:36	0.19	0.11	0.27	0.03	0.22	3.66	0.34	0.12	0.12	0.22	0.06
Total Carbon [%]	27-Feb-07	15:23	1.25	1.36	1.59	2.12	1.01	2.09	1.99	2.07	2.19	1.51	2.01
Carbonate [%]	28-Feb-07	12:58	5.76	6.16	7.23	10.2	4.60	8.94	9.41	9.88	10.8	6.92	9.59



SGS Lakefield Research Limited
P.O. Box 4300 - 185 Concession St.
Lakefield - Ontario - K0L 2H0
Phone: 705-652-2038 FAX: 705-652-6441

Standard ABA (Price 1997) EPA600

LR Report : CA10190-FEB07

Brian Graham B. Sc.
Project Specialist
Environmental Services, Analytical



SGS Lakefield Research Limited
 P.O. Box 4300 - 185 Concession St.
 Lakefield - Ontario - K0L 2H0
 Phone: 705-652-2038 FAX: 705-652-6441

Tormin Resources

Attn : John Cook johncook@kos.net

3155 Hwy 27 RR#2
 Roslin, ON
 K0K 2Y0,

Phone: 613-477-1280
 Fax: 613-477-1248

Standard ABA (Price 1997) EPA600

Friday, March 09, 2007

Date Rec.: 14 February 2007
 LR Report: CA10190-FEB07

Copy: #1

CERTIFICATE OF ANALYSIS

Final Report

Analysis	16:	17:	18:	19:	20:	21:	22:	23:	24:	25:	26:
	PC-04-135 63415	PC-04-135 63417	PC-04-135 63418	PC-04-135 63419	PC-04-136 63420	PC-04-136 63421	PC-04-136 63422	PC-04-137 63423	PC-04-137 63424	PC-04-140 63425	PC-04-140 63426
Paste pH [units]	9.30	9.37	9.35	9.27	9.22	9.21	9.36	9.28	9.15	9.60	9.64
Fizz Rate [---]	4	4	4	4	4	4	4	4	4	4	4
Sample [weight(g)]	2.04	1.97	2.00	2.00	1.99	2.00	2.01	1.98	1.97	2.01	1.98
HCl added [mL]	40.00	40.00	40.00	40.00	40.00	40.00	40.00	40.00	40.00	40.00	40.00
HCl [Normality]	0.50	0.50	0.50	0.50	0.50	0.50	0.50	0.50	0.50	0.50	0.50
NaOH [Normality]	0.50	0.50	0.50	0.50	0.50	0.50	0.50	0.50	0.50	0.50	0.50
NaOH to [pH=7.0 mL]	19.85	20.30	21.00	23.35	23.10	21.50	20.40	21.95	20.55	21.10	20.00
Final pH [units]	1.53	1.58	1.48	1.43	1.47	1.51	1.48	1.48	1.59	1.47	1.54
NP [t CaCO3/1000t]	247	250	238	208	212	231	244	228	247	235	253
AP [t CaCO3/1000 t]	4.2	1.9	2.5	0.31	1.9	3.5	73.4	2.2	12.1	0.62	0.31
Net NP [t CaCO3/1000 t]	243	248	235	208	210	228	170	226	235	234	252
NP/AP [ratio]	59.2	130	94.8	671	113	65.9	3.32	105	20.4	379	815
Total Sulphur [%]	0.231	0.105	0.125	0.014	0.099	0.170	2.77	0.081	0.478	0.024	0.044
Acid Leachable SO4-S [%]	0.10	0.04	0.05	<0.01	0.04	0.06	0.42	0.01	0.09	<0.01	0.03
Sulphide-S [%]	0.13	0.06	0.08	0.01	0.06	0.11	2.35	0.07	0.39	0.02	0.01
Total Carbon [%]	1.92	1.79	2.04	1.44	1.48	1.94	2.11	1.78	1.66	2.32	1.94
Carbonate [%]	9.05	8.42	9.80	6.76	6.53	8.91	8.52	8.63	7.62	11.4	9.44



SGS Lakefield Research Limited
P.O. Box 4300 - 185 Concession St.
Lakefield - Ontario - K0L 2H0
Phone: 705-652-2038 FAX: 705-652-6441

Standard ABA (Price 1997) EPA600

LR Report : CA10190-FEB07

Brian Graham B.Sc.
Project Specialist
Environmental Services, Analytical



SGS Lakefield Research Limited
 P.O. Box 4300 - 185 Concession St.
 Lakefield - Ontario - K0L 2H0
 Phone: 705-652-2038 FAX: 705-652-6441

Tormin Resources

Attn : John Cook johncook@kos.net

3155 Hwy 27 RR#2
 Roslin, ON
 K0K 2Y0,

Phone: 613-477-1280
 Fax: 613-477-1248

Standard ABA (Price 1997) EPA600

Friday, March 09, 2007

Date Rec. : 14 February 2007
 LR Report: CA10190-FEB07

Copy: #1

CERTIFICATE OF ANALYSIS

Final Report

Analysis	27:	28:	29:	30:	31:	32:	33:	34:	35:	36:	37:	38:	39:	40:
	PC-04-140	PC-04-140	PC-04-141	PC-04-141	PC-04-141	PC-04-141	PC-04-141	PC-04-142	PC-04-142	PC-04-142	PC-04-142	PC-04-142	PC-04-142	PC-04-162
	63427	63428	63429	63430	63431	63432	63433	63434	63435	63436	63438	63439	63440	63441
Paste pH [units]	9.41	9.35	9.32	9.02	9.36	9.21	9.45	9.51	9.52	9.37	9.55	9.10	9.29	9.28
Fizz Rate [---]	4	4	4	4	4	4	4	4	4	4	4	4	4	4
Sample [weight(g)]	2.02	2.00	1.99	1.99	2.02	2.03	2.02	2.00	1.99	2.01	2.01	2.00	2.04	2.03
HCl added [mL]	40.00	40.00	40.00	40.00	40.00	40.00	40.00	40.00	40.00	40.00	40.00	40.00	40.00	40.00
HCl [Normality]	0.50	0.50	0.50	0.50	0.50	0.50	0.50	0.50	0.50	0.50	0.50	0.50	0.50	0.50
NaOH [Normality]	0.50	0.50	0.50	0.50	0.50	0.50	0.50	0.50	0.50	0.50	0.50	0.50	0.50	0.50
NaOH to [pH=7.0 mL]	19.80	23.70	24.95	24.40	25.55	23.65	21.80	20.70	23.85	23.75	23.50	23.80	23.50	23.80
Final pH [units]	1.50	1.25	1.26	1.35	1.34	1.55	1.37	1.38	1.38	1.45	1.51	1.56	1.49	1.39
NP [t CaCO3/1000t]	250	204	189	196	179	201	225	241	203	202	205	202	202	200
AP [t CaCO3/1000 t]	0.9	9.6	0.94	22.5	2.2	30.6	0.62	6.8	0.94	4.0	2.7	26.5	2.1	3.6
Net NP [t CaCO3/1000 t]	249	194	188	174	177	171	225	234	202	198	202	176	200	196
NP/AP [ratio]	267	21.3	201	8.73	81.3	6.58	363	35.4	216	51.1	74.7	7.64	97.4	56.2
Total Sulphur [%]	0.094	0.458	0.064	0.911	0.138	1.23	0.034	0.289	0.045	0.184	0.118	1.11	0.090	0.199
Acid Leachable SO4-S [%]	0.06	0.15	0.03	0.19	0.07	0.25	0.01	0.07	0.01	0.06	0.03	0.27	0.02	0.08
Sulphide-S [%]	0.03	0.31	0.03	0.72	0.07	0.98	0.02	0.22	0.03	0.13	0.09	0.85	0.07	0.11
Total Carbon [%]	1.87	1.58	1.31	1.40	1.36	1.57	2.02	2.05	1.71	1.74	1.93	1.41	1.77	1.74
Carbonate [%]	8.85	7.12	6.03	6.16	6.21	6.82	9.67	9.65	8.09	8.02	9.09	6.09	8.23	8.14



SGS Lakefield Research Limited
P.O. Box 4300 - 185 Concession St.
Lakefield - Ontario - K0L 2H0
Phone: 705-652-2038 FAX: 705-652-6441

Standard ABA (Price 1997) EPA600

LR Report: CA10190-FEB07

Brian Graham B. Sc.
Project Specialist
Environmental Services, Analytical



SGS Lakefield Research Limited
 P.O. Box 4300 - 185 Concession St.
 Lakefield - Ontario - K0L 2H0
 Phone: 705-652-2038 FAX: 705-652-6441

Tormin Resources

Attn : John Cook johncook@kos.net

3155 Hwy 27 RR#2
 Roslin, ON
 K0K 2Y0,

Phone: 613-477-1280
 Fax: 613-477-1248

Standard ABA (Price 1997) EPA600

Friday, March 09, 2007

Date Rec. : 14 February 2007
 LR Report: CA10190-FEB07

Copy: #1

CERTIFICATE OF ANALYSIS

Final Report

Analysis	41:	42:	43:	44:	45:	46:	47:	48:	49:	50:	51:	52:	53:	54:
	9.12	9.36	9.18	9.67	9.29	9.38	9.62	9.09	9.07	9.24	9.24	9.03	9.15	9.23
	4	4	4	4	4	4	4	4	4	4	4	4	4	4
Paste pH [units]	2.04	1.99	2.02	2.04	2.02	2.00	1.98	1.99	1.99	2.00	1.97	2.02	1.97	1.97
Fizz Rate [---]	40.00	40.00	40.00	40.00	40.00	40.00	40.00	40.00	40.00	40.00	40.00	40.00	40.00	40.00
Sample [weight(g)]	0.50	0.50	0.50	0.50	0.50	0.50	0.50	0.50	0.50	0.50	0.50	0.50	0.50	0.50
HCl added [mL]	0.50	0.50	0.50	0.50	0.50	0.50	0.50	0.50	0.50	0.50	0.50	0.50	0.50	0.50
HCl [Normality]	23.20	27.80	25.90	26.10	23.80	23.45	25.80	21.20	21.95	24.20	20.60	20.80	20.20	19.85
NaOH [Normality]	1.42	1.32	1.47	1.38	1.32	1.47	1.39	1.56	1.42	1.18	1.33	1.48	1.44	1.35
NaOH to [pH=7.0 mL]	206	153	175	170	200	207	179	236	227	198	246	238	251	256
Final pH [units]	20.7	1.9	3.1	0.31	1.0	3.8	2.8	5.7	25.8	3.6	17.9	15.7	4.0	3.4
NP [t CaCO3/1000t]	185	151	171	170	199	203	176	231	201	194	228	222	247	252
AP [t CaCO3/1000 t]	9.93	82.7	55.7	54.9	193	54.3	62.9	41.6	8.78	54.7	13.7	15.1	62.6	74.5
Net NP [t CaCO3/1000 t]	0.809	0.124	0.161	0.015	0.062	0.172	0.126	0.214	1.06	0.162	0.802	0.664	0.213	0.182
NP/AP [ratio]	0.15	0.06	0.06	0.02	0.03	0.05	0.03	0.03	0.23	0.05	0.23	0.16	0.08	0.07
Total Sulphur [%]	0.66	0.06	0.10	<0.01	0.03	0.12	0.09	0.18	0.83	0.12	0.57	0.50	0.13	0.11
Acid Leachable SO4-S [%]	1.94	0.916	1.59	1.59	1.86	1.92	1.50	1.67	2.09	1.58	1.77	1.47	1.80	2.03
Sulphide-S [%]	8.98	4.12	7.38	7.58	8.84	8.76	6.89	7.74	9.62	7.22	8.07	6.66	8.55	9.78
Total Carbon [%]														
Carbonate [%]														

Data reported represents the sample submitted to SGS. Reproduction of this analytical report in full or in part is prohibited without prior written approval. Please refer to SGS General Conditions of Services located at http://www.sgs.com/terms_and_conditions_service.htm. (Printed copies are available upon request.)
 Test method information available upon request.



SGS Lakefield Research Limited
P.O. Box 4300 - 185 Concession St.
Lakefield - Ontario - K0L 2H0
Phone: 705-652-2038 FAX: 705-652-6441

Standard ABA (Price 1997) EPA600

LR Report: CA10190-FEB07

Brian Graham B.Sc.
Project Specialist
Environmental Services, Analytical



SGS Lakefield Research Limited
 P.O. Box 4300 - 185 Concession St.
 Lakefield - Ontario - K0L 2H0
 Phone: 705-652-2038 FAX: 705-652-6441

Tormin Resources

Attri : John Cook johncook@kos.net

3155 Hwy 27 RR#2, Roslin
 , K0K 2Y0
 Phone: 613-477-1280, Fax:613-477-1248

Friday, March 09, 2007

Date Rec. : 22 February 2007
 LR Report: CA10332-FEB07

Copy: #1

CERTIFICATE OF ANALYSIS

Final Report

Analysis	3: Analysis Approval Date	4: Analysis Approval Time	5: PC-04-124	6: PC-04-126	7: PC-04-127	8: PC-04-135	9: PC-04-142
Sample Date & Time			Date:NA	Date:NA	Date:NA	Date:NA	Date:NA
Paste pH [units]	09-Mar-07	14:41	9.03	8.87	8.98	9.15	9.11
Fizz Rate [---]	09-Mar-07	14:41	4	4	4	4	4
Sample [weight(g)]	09-Mar-07	14:41	2.02	2.02	2.01	1.97	1.99
HCl added [mL]	09-Mar-07	14:41	40.00	40.00	40.00	40.00	40.00
HCl [Normality]	09-Mar-07	14:41	0.50	0.50	0.50	0.50	0.50
NaOH [Normality]	09-Mar-07	14:41	0.50	0.50	0.50	0.50	0.50
NaOH to [pH=7.0 mL]	09-Mar-07	14:41	19.95	20.90	21.90	21.60	23.90
Final pH [units]	09-Mar-07	14:41	1.40	1.39	1.39	1.35	1.36
NP [t CaCO3/1000t]	09-Mar-07	14:41	248	236	225	234	202
AP [t CaCO3/1000 t]	07-Mar-07	15:40	13.1	24.1	15.0	3.1	5.6
Net NP [t CaCO3/1000 t]	09-Mar-07	14:41	235	212	210	230	197
NP/AP [ratio]	09-Mar-07	14:41	18.9	9.81	15.0	75.3	36.1
Total Sulphur [%]	06-Mar-07	13:12	0.565	1.09	0.675	0.230	0.381
Acid Leachable SO4-S [%]	06-Mar-07	15:11	0.15	0.31	0.19	0.12	0.20
Sulphide-S [%]	06-Mar-07	15:11	0.42	0.77	0.48	0.10	0.18
Total Carbon [%]	06-Mar-07	13:11	1.76	1.59	1.65	1.88	1.48
Carbonate [%]	05-Mar-07	07:45	8.49	7.51	7.90	9.22	7.08



SGS Lakefield Research Limited
P.O. Box 4300 - 185 Concession St.
Lakefield - Ontario - K0L 2H0
Phone: 705-652-2038 FAX: 705-652-6441

LR Report : CA10332-FEB07

*NP (Neutralization Potential)
= $50 \times \frac{(N \text{ of HCL} \times \text{Total HCL added} - N \text{ NaOH} \times \text{NaOH added})}{\text{Weight of Sample}}$

*AP (Acid Potential) = % Sulphide Sulphur x 31.25

*Net NP (Net Neutralization Potential) = NP-AP

NP/AP Ratio = NP/AP

*Results expressed as tonnes CaCO₃ equivalent/1000 tonnes of material
Samples with a % sulphide value of <0.01 will be calculated using a 0.01 value.

sulphur analysis performed following BC ARD Guidelines (Price 1997)

Brian Graham B.Sc.
Project Specialist
Environmental Services, Analytical

APPENDIX B

Laboratory Analysis Reports – Whole Rock Analysis by XRF



SGS Lakefield Research Limited
 P.O. Box 4300 - 185 Concession St.
 Lakefield - Ontario - K0L 2H0
 Phone: 705-652-2038 FAX: 705-652-6441

Tormin Resources

Attn : John Cook johncook@kos.net

3155 Hwy 27 RR#2
 Roslin, ON
 K0K 2Y0,

Phone: 613-477-1280
 Fax: 613-477-1248

Thursday, March 08, 2007

Date Rec. : 14 February 2007
 LR Report: CA10191-FEB07

Copy: #1

CERTIFICATE OF ANALYSIS

Final Report

Analysis	3:		4:		5:		6:		7:		8:		9:		10:		11:		12:		13:							
	Analysis Approval Date	PC-04-125 63404	PC-04-126 63407	PC-04-130 63410	PC-04-131 63412	PC-04-137 63426	PC-04-140 63428	PC-04-141 63430	PC-04-141 63432	Analysis Approval Date	PC-04-125 63404	PC-04-126 63407	PC-04-130 63410	PC-04-131 63412	PC-04-137 63426	PC-04-140 63428	PC-04-141 63430	PC-04-141 63432	Analysis Approval Date	PC-04-125 63404	PC-04-126 63407	PC-04-130 63410	PC-04-131 63412	PC-04-137 63426	PC-04-140 63428	PC-04-141 63430	PC-04-141 63432	
Silver [g/t]	07-Mar-07	12:32	0.45	0.27	0.36	0.16	0.44	0.19	0.36	0.70	0.57																	
Aluminum [µg/g]	08-Mar-07	12:08	67000	71000	61000	69000	61000	76000	54000	62000	51000																	
Arsenic [g/t]	07-Mar-07	12:32	< 2	2	< 2	< 2	< 2	< 2	3	< 2	2																	
Barium [µg/g]	08-Mar-07	12:08	77	75	76	70	75	150	110	100	410																	
Beryllium [µg/g]	08-Mar-07	12:08	0.66	0.70	0.79	0.65	0.63	0.69	0.56	0.62	0.68																	
Bismuth [g/t]	07-Mar-07	12:32	0.42	0.21	0.29	0.07	0.43	0.08	0.22	0.67	0.53																	
Calcium [µg/g]	08-Mar-07	12:08	51000	38000	64000	70000	54000	62000	51000	48000	45000																	
Cadmium [µg/g]	08-Mar-07	12:08	1.0	1.1	1.1	0.8	0.9	0.6	0.6	0.9	1.0																	
Cobalt [g/t]	07-Mar-07	12:32	38	35	40	30	32	27	25	35	32																	
Chromium [g/t]	07-Mar-07	12:32	44	48	23	76	71	130	130	72	37																	
Copper [µg/g]	08-Mar-07	12:08	64	60	55	40	54	68	44	92	22																	
Iron [µg/g]	08-Mar-07	12:08	91000	110000	110000	84000	85000	58000	55000	90000	84000																	
Potassium [µg/g]	08-Mar-07	12:08	4100	11000	7400	7000	7600	8900	12000	10000	8500																	
Lithium [µg/g]	08-Mar-07	12:08	10	19	19	18	10	10	7	7	12																	
Magnesium [µg/g]	08-Mar-07	12:08	28000	36000	31000	31000	28000	29000	22000	27000	22000																	
Manganese [µg/g]	08-Mar-07	12:08	1300	1400	1800	1400	1400	1700	990	1700	1400																	
Molybdenum [g/t]	07-Mar-07	12:32	2.8	2.0	2.7	0.91	2.1	0.97	4.5	2.3	3.4																	
Sodium [µg/g]	08-Mar-07	12:08	19000	7700	4500	13000	10000	14000	5800	8200	8400																	
Nickel [g/t]	07-Mar-07	12:32	22	14	15	31	21	48	26	22	11																	
Lead [g/t]	07-Mar-07	12:32	4.3	6.3	7.4	4.7	7.5	9.5	7.6	7.9	8.3																	
Antimony [g/t]	07-Mar-07	12:32	0.3	0.3	0.6	0.1	0.4	0.3	0.1	0.4	0.4																	

Page 1 of 2
 Data reported represents the sample submitted to SGS. Reproduction of this analytical report in full or in part is prohibited without prior written approval. Please refer to SGS General Conditions of Services located at http://www.sgs.com/terms_and_conditions_service.htm. (Printed copies are available upon request.)
 Test method information available upon request.



SGS Lakefield Research Limited
 P.O. Box 4300 - 185 Concession St.
 Lakefield - Ontario - K0L 2H0
 Phone: 705-652-2038 FAX: 705-652-6441

LR Report : CA10191-FEB07

Analysis	3: Approval Date	4: Approval Time	5: PC-04-125 63404	6: PC-04-126 63407	7: PC-04-130 63410	8: PC-04-131 63412	9: PC-04-137 63424	10: PC-04-140 63426	11: PC-04-140 63428	12: PC-04-141 63430	13: PC-04-141 63432
Selenium [g/l]	07-Mar-07	12:32	< 1	< 1	< 1	< 1	< 1	< 1	< 1	< 1	< 1
Tin [g/l]	07-Mar-07	12:32	0.6	0.8	0.5	0.3	0.5	0.5	0.6	0.4	0.3
Strontium [µg/g]	08-Mar-07	12:08	190	140	240	230	210	360	180	180	220
Titanium [µg/g]	08-Mar-07	12:08	1700	2700	560	220	520	200	270	300	240
Thallium [g/l]	07-Mar-07	12:33	0.1	0.2	0.1	0.1	0.1	0.1	0.2	0.1	< 0.1
Uranium [g/l]	07-Mar-07	12:33	0.27	0.37	0.20	0.14	0.20	0.58	0.12	0.21	0.21
Vanadium [µg/g]	08-Mar-07	12:08	300	320	370	270	270	190	210	290	310
Yttrium [g/l]	07-Mar-07	12:33	19	24	20	15	18	10.0	8.7	12	15
Zinc [µg/g]	08-Mar-07	12:08	93	110	130	88	84	70	59	96	100

Brian Graham B.Sc.
 Project Specialist
 Environmental Services, Analytical



SGS Lakefield Research Limited
 P.O. Box 4300 - 185 Concession St.
 Lakefield - Ontario - K0L 2H0
 Phone: 705-652-2038 FAX: 705-652-6441

Tormin Resources

Attn : John Cook johncook@kos.net

3155 Hwy 27 RR#2
 Roslin, ON
 K0K 2Y0.

Phone: 613-477-1280
 Fax: 613-477-1248

Thursday, March 08, 2007

Date Rec. : 14 February 2007
 LR Report: CA10191-FEB07

Copy: #1

CERTIFICATE OF ANALYSIS

Final Report

Analysis	14:	15:	16:	17:	18:	19:	20:	21:	22:	23:	24:
	PC-04-142 63434	PC-04-142 63436	PC-04-142 63439	PC-05-163 63442	PC-05-166 63445	PC-05-167 63447	PC-05-172 63449	PC-05-172 63450	PC-05-174 63452	PC-05-174 63453	PC-05-174 63454
Silver [g/t]	0.29	0.20	0.53	0.36	0.54	0.18	0.20	0.52	0.41	0.45	0.17
Aluminum [µg/g]	62000	68000	67000	70000	84000	68000	60000	59000	60000	61000	59000
Arsenic [g/t]	< 2	< 2	< 2	< 2	< 2	2	< 2	2	3	< 2	< 2
Barium [µg/g]	89	72	77	140	190	97	82	110	130	810	73
Beryllium [µg/g]	0.77	0.73	0.61	0.91	0.92	0.84	0.75	0.70	0.64	0.65	0.72
Bismuth [g/t]	0.26	0.14	0.54	0.39	0.04	0.08	0.15	0.65	0.95	0.30	0.12
Calcium [µg/g]	63000	53000	50000	63000	48000	61000	51000	61000	57000	49000	58000
Cadmium [µg/g]	0.8	0.8	0.9	1.0	0.6	0.9	1.3	0.9	1.0	1.3	1.0
Cobalt [g/t]	38	40	36	33	24	38	33	38	30	33	32
Chromium [g/t]	110	45	35	57	89	180	34	24	87	31	16
Copper [µg/g]	61	50	27	95	150	54	28	80	34	53	35
Iron [µg/g]	78000	90000	120000	100000	64000	82000	98000	89000	73000	110000	100000
Potassium [µg/g]	7000	4500	6500	14000	14000	11000	10000	10000	12000	8600	5500
Lithium [µg/g]	13	22	11	11	13	17	15	15	8	14	18
Magnesium [µg/g]	30000	33000	32000	33000	26000	33000	28000	26000	28000	28000	28000
Manganese [µg/g]	1500	1400	1500	1600	1700	1500	1500	1500	1400	1500	1600
Molybdenum [g/t]	2.1	1.4	4.1	9.7	0.31	1.1	2.2	16	78	3.4	2.4
Sodium [µg/g]	9000	16000	12000	5700	9300	11000	5300	9900	8200	7600	8600
Nickel [g/t]	29	20	9.5	21	20	170	12	14	38	16	8.2
Lead [g/t]	10	5.6	5.5	8.4	9.7	7.2	6.1	7.2	10	6.9	5.7
Antimony [g/t]	0.2	0.2	0.2	0.3	1.4	0.3	0.2	0.6	0.2	0.2	0.2



SGS Lakefield Research Limited
 P.O. Box 4300 - 185 Concession St.
 Lakefield - Ontario - K0L 2H0
 Phone: 705-652-2038 FAX: 705-652-6441

LR Report : CA10191-FEB07

Analysis	14: PC-04-142 63434	15: PC-04-142 63436	16: PC-04-142 63439	17: PC-05-163 63442	18: PC-05-166 63445	19: PC-05-167 63447	20: PC-05-172 63449	21: PC-05-172 63450	22: PC-05-174 63452	23: PC-05-174 63453	24: PC-05-174 63454
Selenium [g/t]	< 1	< 1	< 1	< 1	< 1	< 1	< 1	1	< 1	< 1	< 1
Tin [g/t]	0.4	0.3	0.3	0.5	0.8	0.6	0.6	0.5	0.5	0.6	0.4
Strontium [µg/g]	350	250	200	290	280	300	230	250	240	220	250
Titanium [µg/g]	140	210	330	260	230	630	350	470	320	500	590
Thallium [g/t]	< 0.1	< 0.1	< 0.1	0.4	0.2	0.2	0.2	0.2	0.2	0.1	0.1
Uranium [g/t]	0.18	0.23	0.21	0.22	0.32	0.15	0.13	0.17	0.27	0.16	0.16
Vanadium [µg/g]	260	260	360	310	220	290	380	320	230	330	370
Yttrium [g/t]	12	13	14	15	7.2	17	17	18	14	16	17
Zinc [µg/g]	82	100	120	99	84	97	120	100	82	110	120

Brian Graham B.Sc.
 Project Specialist
 Environmental Services, Analytical



SGS Lakefield Research Limited
P.O. Box 4300 - 185 Concession St.
Lakefield - Ontario - K0L 2H0
Phone: 705-652-2038 FAX: 705-652-6441

Tormin Resources

Attn : John Cook johncook@kos.net

3155 Hwy 27 RR#2, Roslin
, K0K 2Y0
Phone: 613-477-1280, Fax:613-477-1248

Monday, March 12, 2007

Date Rec. : 22 February 2007
LR Report: CA10333-FEB07

Copy: #1

CERTIFICATE OF ANALYSIS
Final Report

Analysis	3: Analysis Approval Date	4: Analysis Approval Time	5: PC-04-124	6: PC-04-126	7: PC-04-135	8: PC-04-142
Sample Date & Time			Date:NA	Date:NA	Date:NA	Date:NA
Silver [g/t]	12-Mar-07	07:49	0.50	0.47	0.20	0.32
Aluminum [µg/g]	12-Mar-07	15:17	68000	61000	59000	54000
Arsenic [g/t]	12-Mar-07	07:49	87	36	15	3
Barium [µg/g]	12-Mar-07	15:17	70	120	110	72
Beryllium [µg/g]	12-Mar-07	15:17	< 0.007	< 0.007	< 0.007	< 0.007
Bismuth [g/t]	12-Mar-07	07:49	0.35	0.46	0.11	0.19
Calcium [µg/g]	12-Mar-07	15:17	59000	50000	59000	46000
Cadmium [µg/g]	12-Mar-07	15:17	0.7	0.8	0.7	0.7
Cobalt [g/t]	12-Mar-07	07:49	32	31	30	28
Chromium [g/t]	12-Mar-07	07:49	28	40	91	42
Copper [µg/g]	12-Mar-07	15:17	66	130	110	81
Iron [µg/g]	12-Mar-07	15:17	87000	96000	74000	94000
Potassium [µg/g]	12-Mar-07	15:17	5500	11000	11000	5500
Lithium [µg/g]	12-Mar-07	15:17	< 3	< 3	10	< 3
Magnesium [µg/g]	12-Mar-07	15:17	28000	27000	28000	25000
Manganese [µg/g]	12-Mar-07	15:17	1200	1400	1200	1500
Molybdenum [g/t]	12-Mar-07	07:49	2.6	11	2.2	2.6
Sodium [µg/g]	12-Mar-07	15:17	20000	6500	6300	5700
Nickel [g/t]	12-Mar-07	07:49	27	17	36	14
Lead [g/t]	12-Mar-07	07:49	9.8	6.0	7.6	5.7
Antimony [g/t]	12-Mar-07	07:49	1.1	0.9	0.8	0.5
Selenium [g/t]	12-Mar-07	07:49	< 1	< 1	< 1	< 1
Tin [g/t]	12-Mar-07	07:49	0.5	0.6	0.4	0.4
Strontium [µg/g]	12-Mar-07	15:17	240	180	240	210
Titanium [µg/g]	12-Mar-07	15:17	620	480	250	250
Thallium [g/t]	12-Mar-07	07:49	0.1	0.2	0.2	< 0.1
Uranium [g/t]	12-Mar-07	07:49	0.19	0.18	0.18	0.11



SGS Lakefield Research Limited
P.O. Box 4300 - 185 Concession St.
Lakefield - Ontario - KOL 2H0
Phone: 705-652-2038 FAX: 705-652-6441

LR Report : CA10333-FEB07

Analysis	3: Analysis Approval Date	4: Analysis Approval Time	5: PC-04-124	6: PC-04-126	7: PC-04-135	8: PC-04-142
Vanadium [$\mu\text{g/g}$]	12-Mar-07	15:17	240	300	230	290
Yttrium [g/t]	12-Mar-07	07:49	20	17	13	12
Zinc [$\mu\text{g/g}$]	12-Mar-07	15:17	96	93	81	100

Brian Graham B.Sc.
Project Specialist
Environmental Services, Analytical

APPENDIX C

Laboratory Analysis Reports – Bulk Metal Analysis by ICP



SGS Lakefield Research Limited
P.O. Box 4300 - 185 Concession St.
Lakefield - Ontario - K0L 2H0
Phone: 705-652-2038 FAX: 705-652-6441

Tormin Resources

Attn : John Cook johncook@kos.net

3155 Hwy 27 RR#2
Roslin, ON
K0K 2Y0,

Phone: 613-477-1280
Fax:613-477-1248

Thursday, March 08, 2007

Date Rec. : 14 February 2007
LR Report: CA10192-FEB07
Reference: Whole Rock Analysis

Copy: #1

CERTIFICATE OF ANALYSIS
Final Report

Analysis	5: PC-04-124 63402	6: PC-04-125 63403	7: PC-04-126 63405	8: PC-04-130 63411	9: PC-04-131 63413	10: PC-04-135 63417	11: PC-04-135 63418	12: PC-04-136 63421	13: PC-04-137 63423
SiO2 [%]	45.8	46.2	43.1	42.2	45.8	45.6	45.4	44.1	47.3
Al2O3 [%]	11.8	12.0	12.8	12.4	11.8	13.4	12.3	12.1	12.6
Fe2O3 [%]	15.7	14.9	12.7	13.0	15.8	11.0	11.7	13.6	11.4
MgO [%]	4.75	4.17	4.19	5.50	4.53	5.73	4.63	4.68	5.15
CaO [%]	8.09	8.25	9.70	10.2	7.20	8.11	9.46	9.16	8.38
Na2O [%]	2.57	3.48	3.03	2.09	2.47	1.19	1.75	2.01	1.08
K2O [%]	0.10	0.04	0.31	0.43	0.12	0.95	0.86	0.62	0.98
TiO2 [%]	2.39	2.59	1.79	1.82	2.41	1.53	1.66	1.99	1.52
P2O5 [%]	0.37	0.50	0.25	0.29	0.38	0.18	0.25	0.29	0.23
MnO [%]	0.22	0.23	0.18	0.22	0.18	0.17	0.18	0.20	0.19
Cr2O3 [%]	< .01	< .01	< .01	0.01	< .01	0.02	0.01	< .01	0.02
V2O5 [%]	0.08	0.07	0.07	0.06	0.09	0.06	0.06	0.07	0.05
LOI [%]	7.18	7.22	10.8	11.0	8.21	10.6	10.8	10.2	10.6
Sum [%]	99.1	99.6	99.0	99.3	99.0	98.5	99.0	99.0	99.5

Brian Graham B.Sc.
Project Specialist
Environmental Services, Analytical



SGS Lakefield Research Limited
 P.O. Box 4300 - 185 Concession St.
 Lakefield - Ontario - K0L 2H0
 Phone: 705-652-2038 FAX: 705-652-6441

Tormin Resources

Attn : John Cook johncook@kos.net

3155 Hwy 27 RR#2
 Roslin, ON
 K0K 2Y0,

Phone: 613-477-1280
 Fax:613-477-1248

Thursday, March 08, 2007

Date Rec. : 14 February 2007
 LR Report: CA10192-FEB07
 Reference: Whole Rock Analysis

Copy: #1

CERTIFICATE OF ANALYSIS
Final Report

Analysis	14: PC-04-140 63427	15: PC-04-141 63429	16: PC-04-141 63433	17: PC-04-142 63435	18: PC-04-142 63438	19: PC-04-142 63440	20: PC-05-164 63443	21: PC-05-165 63444	22: PC-05-168 63448	23: PC-05-175 63455
SiO2 [%]	45.3	52.0	43.7	48.0	46.3	46.8	47.6	46.2	50.2	43.2
Al2O3 [%]	12.9	13.2	14.0	12.4	11.8	11.4	13.9	12.9	14.8	13.2
Fe2O3 [%]	12.1	10.3	10.1	12.5	13.3	14.0	12.0	11.9	8.30	11.5
MgO [%]	6.01	4.74	5.92	4.95	4.98	4.75	5.63	5.26	4.66	5.50
CaO [%]	8.36	6.13	9.49	7.94	8.98	8.30	7.52	7.81	7.17	9.69
Na2O [%]	0.56	2.80	2.18	1.35	1.24	1.25	3.30	3.34	2.91	1.55
K2O [%]	0.92	0.79	0.57	0.64	0.38	0.48	0.37	0.15	0.96	1.13
TiO2 [%]	1.60	1.42	1.43	1.71	1.82	2.05	1.77	1.74	0.68	1.75
P2O5 [%]	0.18	0.23	0.21	0.22	0.29	0.31	0.32	0.30	0.10	0.25
MnO [%]	0.17	0.21	0.17	0.18	0.20	0.20	0.22	0.23	0.16	0.17
Cr2O3 [%]	0.01	0.02	0.03	< .01	0.01	< .01	0.02	< .01	0.02	0.02
V2O5 [%]	0.07	0.04	0.05	0.06	0.06	0.07	0.05	0.05	0.04	0.06
LOI [%]	10.9	7.98	11.3	9.86	10.5	9.98	6.72	8.67	8.76	11.2
Sum [%]	99.0	99.9	99.2	99.8	99.9	99.6	99.4	98.6	98.7	99.3

Brian Graham B.Sc.
Project Specialist
Environmental Services, Analytical

APPENDIX D

Laboratory Analysis Reports – Solubility



SGS Lakefield Research Limited
 P.O. Box 4300 - 185 Concession St.
 Lakefield - Ontario - K0L 2H0
 Phone: 705-652-2038 FAX: 705-652-6441

Tormin Resources

Attn : John Cook johncook@kos.net

3155 Hwy 27 RR#2
 Roslin, ON
 K0K 2Y0,

Phone: 613-477-1280
 Fax: 613-477-1248

CERTIFICATE OF ANALYSIS

Final Report

Shake Flask DI Leach 3:1 Ratio

Friday, April 20, 2007

Date Rec.: 09 April 2007
 LR Report: CA10155-APR07

Copy: #1

Analysis	3: Approval Date	4: Analysis Approval Time	5: PC-04-127 63408	6: PC-04-136 63422	7: PC-04-141 63432	8: PC-04-142 63439	9: PC-04-141 63430	10: PC-05-172 63450	11: PC-05-163 63442	12: PC-04-124 63402	13: PC-04-131 63413	14: PC-04-142 63434	15: PC-05-172 63449	16: PC-04-142 63436
Sample Date & Time	18-Apr-07	14:06	17-Apr-07	17-Apr-07	17-Apr-07	17-Apr-07	17-Apr-07	17-Apr-07	17-Apr-07	17-Apr-07	17-Apr-07	17-Apr-07	17-Apr-07	17-Apr-07
Sample [weight(g)]	300	300	300	300	300	300	300	300	300	300	300	300	300	300
Volume mL [D.I. H2O]	900	900	900	900	900	900	900	900	900	900	900	900	900	900
Initial pH [units]	9.39	9.74	9.74	9.83	9.77	9.90	9.77	9.44	9.52	9.67	9.63	9.91	9.52	9.85
Final pH [units]	8.71	8.83	8.71	8.83	9.13	9.34	9.05	8.96	9.07	9.23	9.13	9.60	9.12	9.45
Silver [mg/L]	< 0.0001	< 0.0001	< 0.0001	< 0.0001	< 0.0001	< 0.0001	< 0.0001	< 0.0001	< 0.0001	< 0.0001	< 0.0001	< 0.0001	< 0.0001	< 0.0001
Aluminum [mg/L]	0.41	0.39	0.41	0.39	0.69	1.19	0.58	0.48	0.11	0.66	0.61	1.22	0.65	0.95
Arsenic [mg/L]	0.0002	0.0003	0.0002	0.0003	0.0003	0.0002	< 0.0002	< 0.0002	0.0003	< 0.0002	< 0.0002	0.0002	< 0.0002	< 0.0002
Boron [mg/L]	0.021	0.003	0.003	0.003	0.007	0.006	0.005	0.008	0.258	0.010	0.004	0.010	0.005	0.004
Beryllium [mg/L]	< 0.0004	< 0.0004	< 0.0004	< 0.0004	< 0.0004	< 0.0004	< 0.0004	< 0.0004	< 0.0004	< 0.0004	< 0.0004	< 0.0004	< 0.0004	< 0.0004
Bismuth [mg/L]	0.0004	< 0.0002	< 0.0002	< 0.0002	< 0.0002	< 0.0002	< 0.0002	< 0.0002	< 0.0002	< 0.0002	< 0.0002	< 0.0002	< 0.0002	< 0.0002
Calcium [mg/L]	22.5	16.5	22.5	16.5	8.11	4.85	10.5	13.4	10.6	8.82	10.2	2.71	9.86	4.59
Cadmium [mg/L]	< 0.00006	< 0.00006	< 0.00006	< 0.00006	< 0.00006	< 0.00006	< 0.00006	< 0.00006	< 0.00006	< 0.00006	< 0.00006	< 0.00006	< 0.00006	< 0.00006
Cobalt [mg/L]	0.00030	0.00044	0.00030	0.00044	< 0.00007	< 0.00007	< 0.00007	0.00010	< 0.00007	0.00043	< 0.00007	< 0.00007	< 0.00007	< 0.00007
Chromium [mg/L]	< 0.0003	< 0.0003	< 0.0003	< 0.0003	< 0.0003	< 0.0003	< 0.0003	< 0.0003	0.0010	< 0.0003	< 0.0003	0.0004	< 0.0003	< 0.0003
Copper [mg/L]	0.0003	0.0004	0.0003	0.0004	0.0002	0.0002	0.0002	0.0002	0.0004	0.0003	0.0002	0.0003	0.0002	0.0003
Iron [mg/L]	< 0.01	< 0.01	< 0.01	< 0.01	< 0.01	< 0.01	< 0.01	< 0.01	< 0.01	< 0.01	< 0.01	0.04	< 0.01	< 0.01
Potassium [mg/L]	4.97	4.13	4.97	4.13	6.02	4.42	6.76	8.24	5.30	0.92	1.59	3.67	5.66	2.43
Lithium [mg/L]	< 0.002	< 0.002	< 0.002	< 0.002	< 0.002	< 0.002	< 0.002	< 0.002	< 0.002	< 0.002	< 0.002	< 0.002	< 0.002	< 0.002
Magnesium [mg/L]	3.14	3.22	3.14	3.22	1.51	0.641	2.60	2.88	2.00	1.45	1.89	0.462	1.77	0.710
Manganese [mg/L]	0.005	0.004	0.005	0.004	0.002	< 0.001	0.002	< 0.001	< 0.001	0.002	0.002	< 0.001	0.002	< 0.001
Molybdenum [mg/L]	0.00958	0.0139	0.00958	0.0139	0.0369	0.00182	0.00172	0.00907	0.00715	0.00111	0.00052	0.00136	0.00139	0.00120
Sodium [mg/L]	8.46	9.03	8.46	9.03	19.8	29.9	6.11	4.71	11.2	6.74	5.93	34.0	3.92	15.9
Nickel [mg/L]	< 0.0007	0.0010	< 0.0007	0.0010	< 0.0007	< 0.0007	< 0.0007	< 0.0007	< 0.0007	< 0.0007	< 0.0007	< 0.0007	< 0.0007	< 0.0007
Lead [mg/L]	< 0.00002	< 0.00002	< 0.00002	< 0.00002	< 0.00002	< 0.00002	< 0.00002	< 0.00002	< 0.00002	0.00008	< 0.00002	< 0.00002	< 0.00002	< 0.00002



SGS Lakefield Research Limited
 P.O. Box 4300 - 185 Concession St.
 Lakefield - Ontario - K0L 2H0
 Phone: 705-652-2038 FAX: 705-652-6441

Shake Flask DI Leach 3:1 Ratio

LR Report: CA10155-APR07

Analysis	3: Analysis Approval Date	4: Analysis Approval Time	5: PC-04-127 63408	6: PC-04-136 63422	7: PC-04-141 63432	8: PC-04-142 63439	9: PC-04-141 63430	10: PC-05-172 63450	11: PC-05-163 63442	12: PC-04-124 63402	13: PC-04-131 63413	14: PC-04-142 63434	15: PC-05-172 63449	16: PC-04-142 63436
Antimony [mg/L]	20-Apr-07	10:17	0.0010	0.0010	0.0010	0.0008	0.0007	0.0006	0.0006	0.0008	0.0005	0.0010	0.0004	0.0006
Selenium [mg/L]	20-Apr-07	10:17	0.003	0.003	< 0.001	< 0.001	< 0.001	< 0.001	< 0.001	< 0.001	< 0.001	< 0.001	< 0.001	< 0.001
Tin [mg/L]	20-Apr-07	10:17	0.0015	0.0013	0.0007	0.0005	< 0.0003	0.0005	0.0004	< 0.0003	< 0.0003	< 0.0003	< 0.0003	< 0.0003
Strontium [mg/L]	20-Apr-07	07:49	0.144	0.147	0.264	0.0824	0.197	0.142	0.113	0.0753	0.100	0.0669	0.0676	0.0862
Titanium [mg/L]	20-Apr-07	10:17	0.0008	0.0007	0.0003	0.0003	< 0.0002	< 0.0002	< 0.0002	0.0002	< 0.0002	< 0.0002	< 0.0002	< 0.0002
Thallium [mg/L]	20-Apr-07	10:17	< 0.0001	< 0.0001	< 0.0001	< 0.0001	< 0.0001	< 0.0001	< 0.0001	< 0.0001	< 0.0001	< 0.0001	< 0.0001	< 0.0001
Uranium [mg/L]	20-Apr-07	10:17	0.00003	0.00002	< 0.00002	< 0.00002	< 0.00002	< 0.00002	< 0.00002	< 0.00002	< 0.00002	< 0.00002	< 0.00002	< 0.00002
Vanadium [mg/L]	20-Apr-07	10:17	0.00131	0.00122	0.00254	0.00477	0.00250	0.00150	0.00180	0.00375	0.00212	0.00729	0.00205	0.00394
Tungsten [mg/L]	20-Apr-07	10:17	0.00176	0.00151	0.00164	0.00282	0.00214	0.00123	0.00128	0.00105	0.00058	0.00124	0.00105	0.00074
Yttrium [mg/L]	20-Apr-07	10:17	0.000008	0.000007	0.000010	0.000006	< 0.000005	0.000005	0.000021	0.000017	0.000006	< 0.000005	< 0.000005	< 0.000005
Zinc [mg/L]	20-Apr-07	10:17	< 0.0003	0.0008	0.0003	0.0074	< 0.0003	0.0004	0.0091	0.0007	< 0.0003	0.0005	< 0.0003	< 0.0003

Brian Graham B.Sc.
 Project Specialist
 Environmental Services, Analytical

Appendix L

Argyle Regional Features – Baie Verte Peninsula

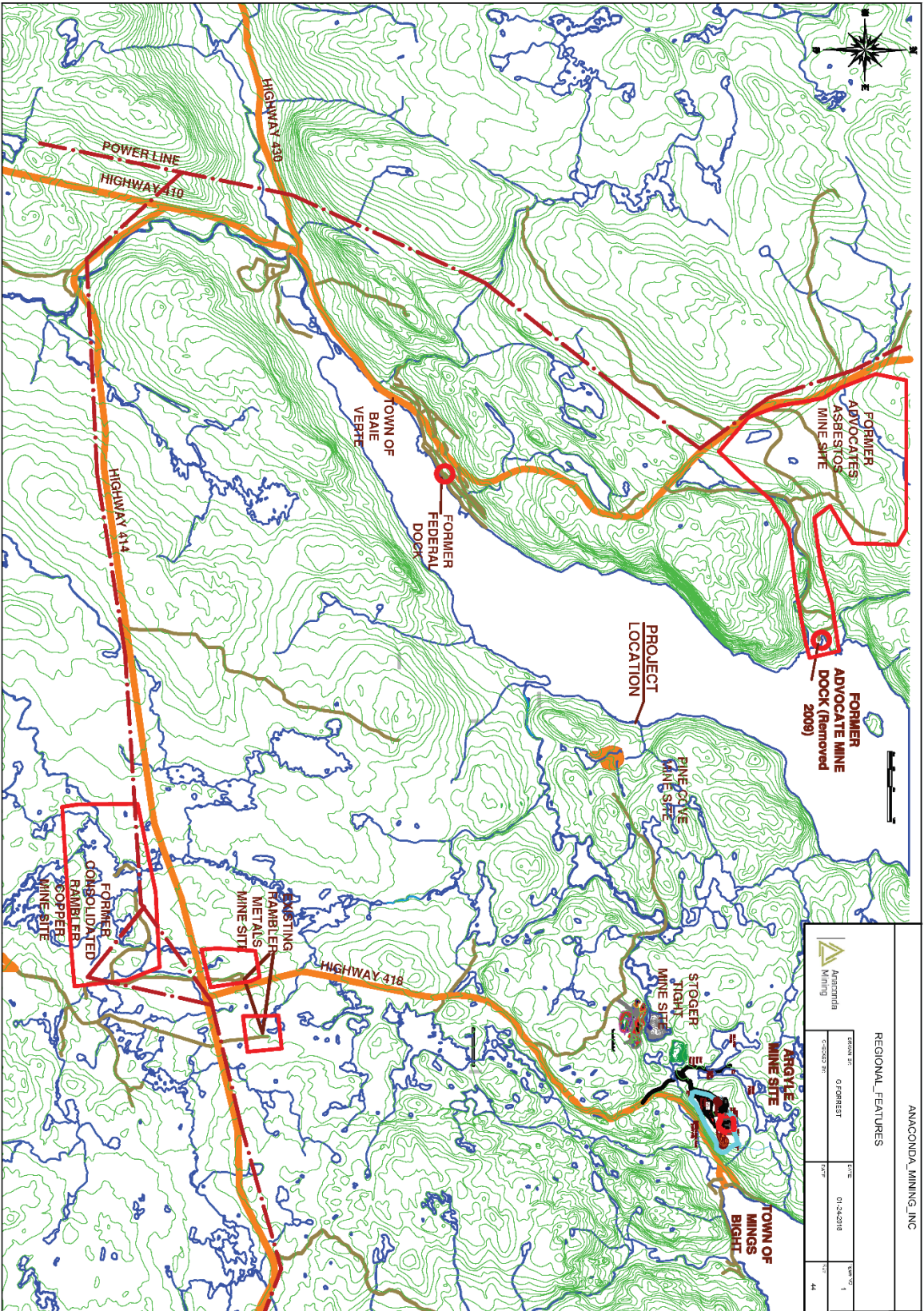

ANACONDA MINING, INC.

REGIONAL FEATURES		
	TOWN OF	DATE
	OF FOREST	01-24-2010
		SCALE
		1" = 1
		44

Appendix M

Argyle Regional Features – Stog'er Tight and Argyle Area

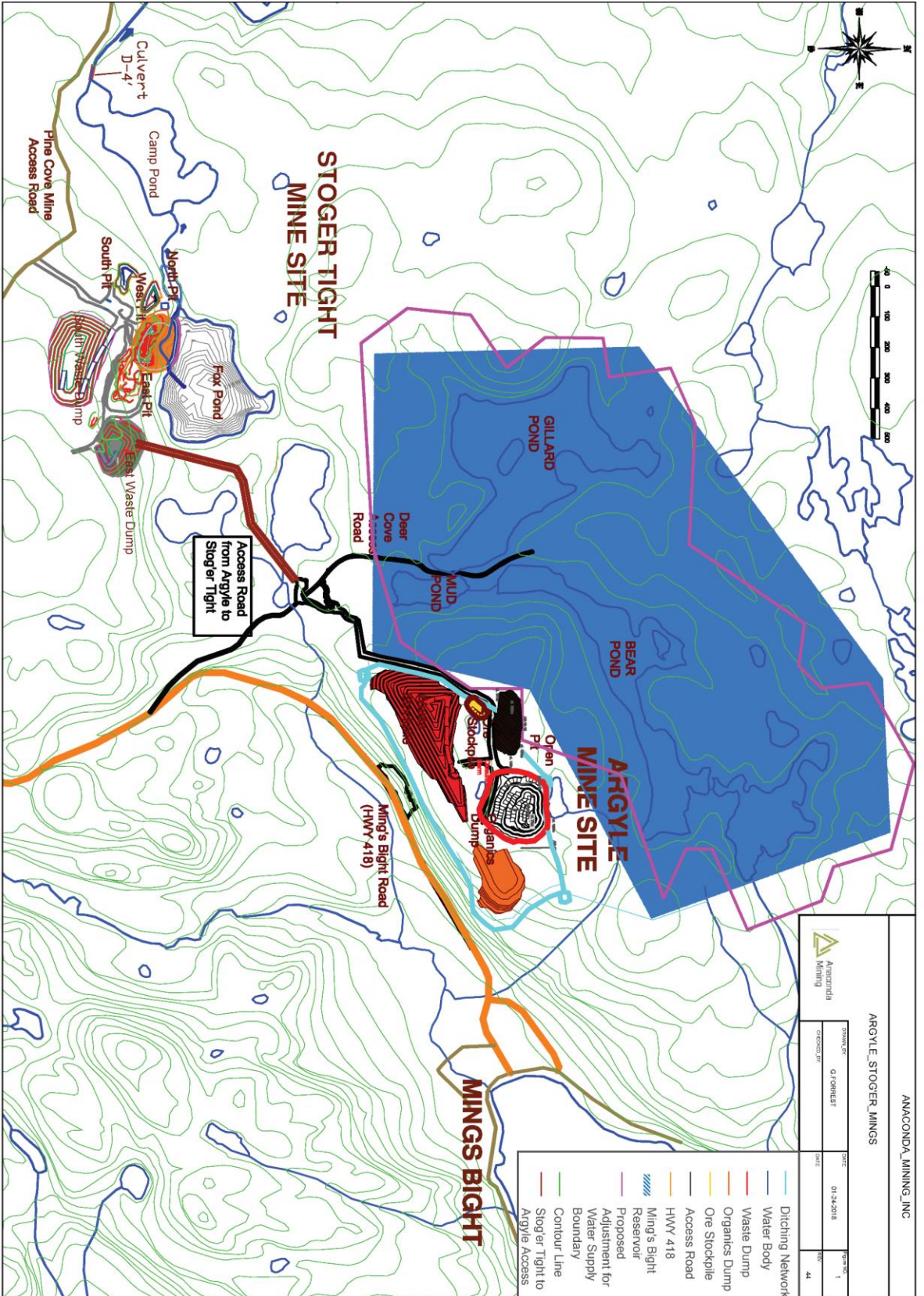

ANACONDA MINING INC

ARGYLE_STOGER_MINGS

PROJECT NO.	01/09/HEAT	DATE	01/24/2018	FIGURE NO.	1
DRAWN BY		REV		REV	44

- Ditching Network
- Water Body
- Waste Dump
- Organics Dump
- Ore Stockpile
- Access Road
- HWY 418
- ▨ Mings' Bight Reservoir
- Proposed
- Adjustment for Water Supply Boundary
- Contour Line
- Stogger Tight to Argyle Access