

APPENDIX D
Potential Shale Oil Development
in the Green Point Shale, Western Newfoundland:
Hydraulic Fracturing and Wellbore Integrity

**Potential Shale Oil Development
in the Green Point Shale, Western Newfoundland:
Hydraulic Fracturing and Wellbore Integrity**

Maurice B. Dusseault, PEng, PhD
University of Waterloo, Waterloo, ON

ABSTRACT

Potential hydrocarbon development onshore and offshore Western Newfoundland would involve production from the Green Point shale, the common name for the Green Point Formation, a low-permeability and naturally fractured formation of late Cambrian and early Ordovician age. In such strata, development would be based on long horizontal production wells with multiple stages of hydraulic fractures along the length of the wells to enhance the production rate of fluids from the target horizon. Production wells would almost certainly be re-stimulated by hydraulic fracture treatment one or more times during their productive life, and wellbores and surface facilities would require ongoing technical activities to maintain integrity, productivity, and environmental security.

Drilling of horizontal wells followed by multi-stage hydraulic fracturing is a major industrial activity, as during the development phase each well may cost on the order of six to eight million dollars, and there may be 10-16 wells per drilling site. This multiple-well-per-site approach means a local concentration of industrial activity for a longer period of time, increasing the local risk of environmental impact (scale of several hectares), despite decreasing the regional impact (scale of many square kilometers) because far fewer sites are needed for resource development. Furthermore, to support many years of production, there will be hydrocarbon processing facilities built on some of the sites for treatment and transshipment of fluids (gas, oil, produced water). A fluid gathering system implies flow lines feeding into larger pipelines and transmission via these pipelines to a marine loading terminal for the oil, a natural gas distribution system, or a disposal facility for the non-recyclable waste water.

Drilling and hydraulic fracturing operations may involve the use of chemicals that, if improperly transported, stored, or used, could have environmental or safety impacts. However, within the hydraulic fracturing industry, there is a strong trend toward reduction of the need for hazardous materials, and the regulation of surface operations is a mature part of society activities that warrants only a few further comments. The means to reduce environmental, technical and safety risks associated with surface transportation and site activities (e.g. high pressure fracturing systems) are well-established, and are typically mandated within an appropriate regulatory framework, enforced through a system of rules, inspections, self-reporting of incidents, and appropriate remedies and penalties. These are promulgated by Government ministries (e.g. Environment, Health) and regulatory bodies (e.g. Occupational Health and Safety).

There is little need to emphasize or discuss risks associated with such surface activities and the guidelines needed to responsibly manage surface activities are well-known. Nonetheless, the process of drilling, fracturing and producing a pad containing 10-16 wells is not a small industrial process: it involves expenditures on the order of 100 million dollars, and many months to two years of intensive activity on a site (Figure 1), not counting the long period of production and eventually decommissioning of the site. Such endeavours must be reasonably regulated.

The processes of drilling, well installation, and hydraulic fracturing are deemed to be safe processes in the context of general risk to personnel and to the environment. The construction, forestry and transportation industries are the most dangerous industries in Canada in terms of personal risk, far greater than the oil and gas industry. Well-understood principles exist to assess and manage risks on an on-going basis, and methods exist to reduce the risk when it is considered appropriate. Based on experience with drilling wells in well understood shale formations and for a number of geological and mechanical reasons, risks of fracturing fluids rising from depth of 1000-3000 m to the groundwater zone are close to zero. For a potential development scheme involving 500 wells, it is quite unlikely that even one HF stimulation operation at depth would intersect the surface groundwater. A small risk exists that a well could rupture at a higher elevation during active fracturing, but this is a rare event, and is also considered unlikely. This extremely low probability does not mean that careful geological studies and quality control are not warranted: these are always valuable in the context of complex operations in a geologically complex environment.



Figure 1. Hydraulic fracturing operations at a multi-well pad in the United States.

Long-term wellbore integrity remains an issue of concern in oil and gas resource development because, despite the industrial maturity of the well completion and management processes, a small percentage of wells develop slow seepage of fluids, almost invariably natural gas, from depth toward the surface, even after proper decommissioning of the wells has taken place. Nevertheless, the risks remain low because the number of incidents appear to be small (several percent of wellbores), the fluid leaking is almost always natural gas which has no human toxicity impacts, and the environmental impact of slow natural gas seepage is low. The amount of natural gas that might be emitted to the atmosphere from leaking energy wells is trivial compared to other sources of fugitive methane (cattle, leaky distribution systems, anaerobic decomposition of landfills, etc.). Furthermore, contamination of domestic water wells by methane sourced from energy wells appears to be uncommon.

Based on studies undertaken elsewhere, and upon review of portions of the relevant scientific and engineering literature, this report arrives at the following conclusions:

- No socioeconomically beneficial industrial activity is without some negative risk. It is the responsibility of authorized agencies, acting on the basis of suitable scientific and engineering information, to assess whether risks are properly managed and mitigated on behalf of the owners of the resource so that development can go forward with net positive benefits to society at large.
- The potential negative environmental impacts of drilling, hydraulic fracturing, operating and decommissioning oil and gas wellbores are well understood; best practices have been clearly established by industry and regulatory agencies elsewhere, and for all known risks, there are methods to reduce both consequences and likelihood of an incident.
- In any new development region, the collection of baseline data is recommended in areas such as groundwater geochemistry, surface water quality, atmospheric emissions and induced seismicity. These activities are recommended to precede and continue during any development in the Port au Port Bay area and surrounding regions underlain by Green Point shale strata that could be deemed potentially commercial.

- It is feasible and reasonable to ask of resource development companies to put into place methods of process quality control and monitoring to ensure to the owners of the resource that exploitation is taking place with due regard to standards and expectations set by the society as represented through the mandate of the regulatory agency. Some additional recommendations are made in this regard within this report.
- Whereas during oil and gas development there will always be some industrial accidents (e.g. spills, unintended releases) and mechanical failures (e.g. a wellbore developing a slow fluid leakage path), these appear to present lower risks in the case of Western Newfoundland because there are few legacy wellbores, development will be of new wells, modern completion and production practices will be required, and so on. Even transportation risks (road traffic) might be modest if marine transport of equipment and materials proves economically feasible.
- There are no apparent significant technical or environmental barriers to the development of the oil resources in the Green Point shale. As stated previously, this does not mean that studies are not worthwhile; it is always necessary, and especially in new and complex cases, to gather information and continue to evaluate risks and outcomes.

ABBREVIATIONS AND SYMBOLS

BGWP	Base of GroundWater Protection – the lowest occurrence of useable water, defined consistently by an accepted standard (e.g. 3000 parts per million total dissolved solids).	σ_3	Smallest compressive stress at a point in the earth – controls the orientation of the hydraulic fracture plane.
HF	Hydraulic Fracturing (or hydraulic fractures).	σ_{hmin}	Smallest horizontal stress at a point in the earth (note that the vertical stress could be smaller than this value in a “thrust fault” regime or near the earth’s surface).
HC	HydroCarbons – oil and gas comprising the economic target of the O&G activity.	σ_v	Vertical stress, generally taken to be one of the three principal stresses ($\sigma_1, \sigma_2, \sigma_3$), and also taken to be a direct function of the weight of the overburden strata, $\sigma_v \approx \rho \cdot g \cdot z$, where ρ is the average bulk density of the overlying rocks, g is the gravitational acceleration, and z is the depth.
GW	GroundWater – the potable water zone at and near the surface that is connected to the surface flow systems and which constitutes a source of consumable water for various purposes.	p_f	Fluid pressure in a hydraulic fracture.
O&G	Oil and Gas – as in “O&G exploration activity...” or “O&G industry developments...”	p_o	Original fluid pressure in the geological strata.
NFR	Naturally Fractured Rock – as in “Fracturing processes in a NFR are dominated by...”		
MSHF	Multi-Stage Hydraulic Fracture – multiple hydraulic fracture installations undertaken sequentially in a vertical or horizontal well to increase the productivity of the well.		

INTRODUCTION

Nature of Potential O&G Development in Western Newfoundland

Development of the potential hydrocarbon (HC) resources in Western Newfoundland in the Port au Port Bay and potentially some of the surrounding offshore area may take place sometime in the future. If development takes place, the scheme will involve limited-area sites (pads) with multiple wells, all of them likely to be horizontal in attitude within the reservoir, and all of them subjected to hydraulic fracturing (HF) as a production stimulation method to permit economic production rates. The development scheme will correspond roughly to the image shown in Figure 2, where widely spaced development pads are used for multiple wells, with each development pad draining a large subsurface area, and each horizontal well section HF stimulated at 20-30 locations along its length.

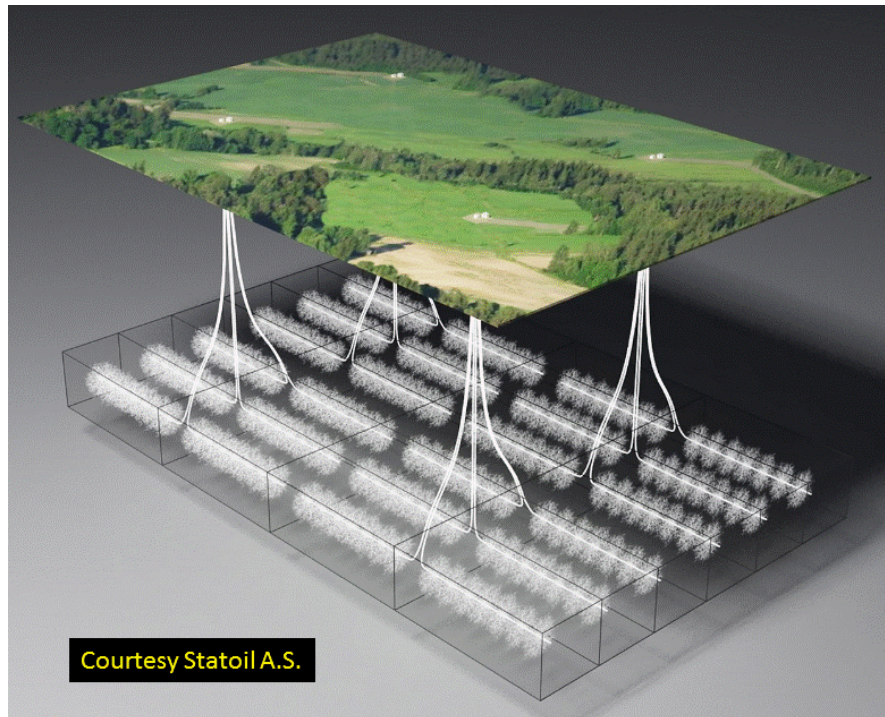

Figure 2. Multiwell pad drilling reduces surface impacts.

Figure 2, a conceptual diagram only, shows six wells installed at each pad. Depending on the local depth to the Green Point shale that is considered to be prospective for oil and gas in Western Newfoundland, as well as its thickness and the response of the shale to HF stimulation, it is likely that from 12 to 16 wells per pad would be installed, each from 2 to 3 km horizontal length, and spaced laterally to drain from an area of 6 to 8 km². If extended reach drilling is used to access parts of the Green Point Formation that are farther offshore (Figure 3), it is conceivable that each pad could have over 25-30 wells covering a subsurface area of up to or even more than 15 km², depending on the lateral spacing that is found to be necessary to give good recovery values. Furthermore, depending on the thickness of the Green Point shale and its response to stimulation, it is possible that two levels of horizontal wells could be used to best develop the resource, and this might result in a larger number per wells at each site

Figure 3 shows one possible future arrangement of several development pads that would drain subsurface areas of up to 20 km². This figure also illustrates the "onshore-to-offshore" concept that would likely be applied in the Port au Port Bay area, the region of the Green Point shale which is currently considered to have the best potential for commercial production. In the Figure, it is assumed that each horizontal well section is 2.5 km long (reasonable by

current standards) and that there are extended reach wells where the drilling proceeds 2.5 km laterally before drilling the 2.5 km long horizontal section. Shallower wells would have different dimensions. Many scenarios are possible, and geometry speculation encounters the challenges of rapid technological progress and uncertainty regarding the potential commercial viability of the Green Point Formation source rock.

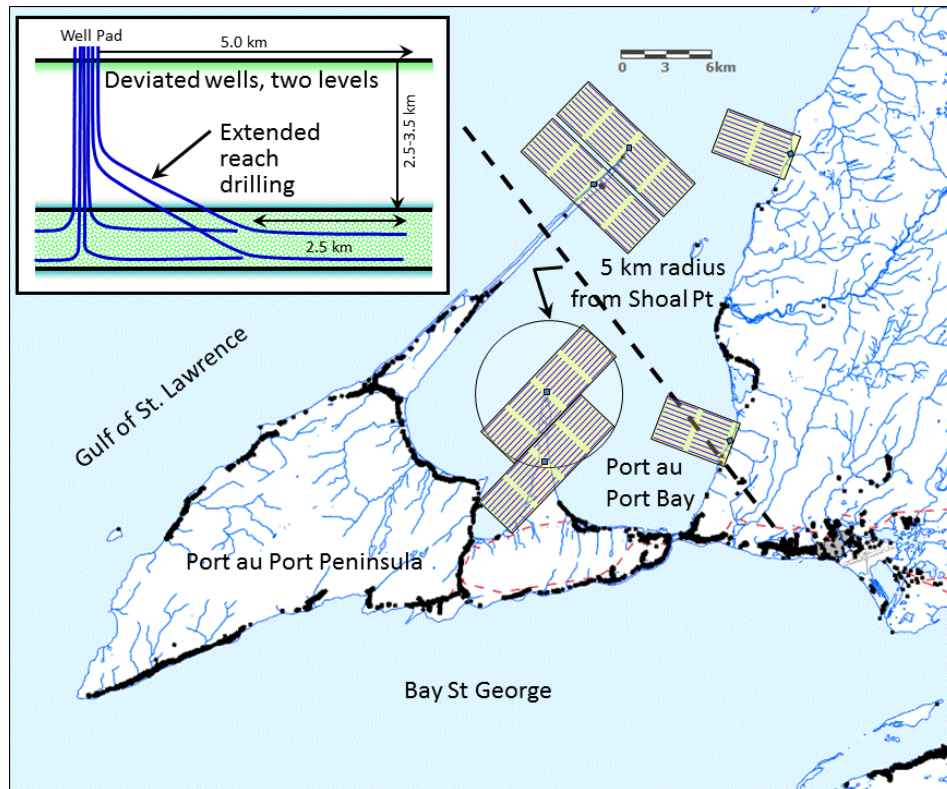

Figure 3. Potential footprint of extended reach horizontal well pads.

Understanding the nature of typical oil and gas (O&G) development methods that might occur in Western Newfoundland is part of a broad assessment of the socioeconomic and environmental feasibility of going forward to establish a development plan. It is not possible to be highly specific about the development details. Technology is evolving rapidly; typical horizontal wells are being drilled to greater lengths (up to 3 km is common), drilling speeds increasing (cost reductions), and extended-reach drilling allows reaching targets several km from the well site. Hydraulic fracturing technologies are also changing and becoming more efficient, with shorter times needed to achieve similar results. Optimum well orientation (azimuth of the horizontal section), lateral spacing between wells, fracture stage spacing along the well axis, and treatment volume per stage, can only be decided once additional geoscience and engineering data become available through exploration and technology trials. These decisions require more precise seismic surveys, stratigraphic drilling to assess the detailed geological nature of the potentially commercial development, assessment of hydraulic fracturing efficacy, and initial production trials. Even then, modifications to the development plan will occur as more information is collected. This process of adaptive management that takes place as more information is gradually collected is typical of engineering projects that must deal with various types of uncertainty (geological uncertainty, price uncertainty, cost uncertainty...), such as mining and O&G projects¹. To quote directly from [1]:

¹ Williams B.K., Brown E.D., and 36 other contributors. 2012. Adaptive Management. US Department of the Interior Applications Guides. x + 120 pages, ISBN 978-0-615-59913-7.

"As the scope and complexity of resource problems grow, it will be increasingly important to make resource decisions in a structured and transparent way that is based on science and accounts for uncertainty. Because adaptive management meets these conditions, it can be a valuable template for effective decision making by managers..." [1], p viii.

A great deal of literature has become available in the last five years on shale gas and shale oil technology and environmental issues; only a small fraction of the papers has been reviewed and is discussed here. For an overview of shale gas geoscience and environmental issues in Canada, the Geological Survey of Canada has published a series of articles that can be accessed through their website.^{2,3}

This report on drilling, HF, wellbore integrity and deep well injection will not enter into exhaustive detail of the technical and regulatory aspects of potential HC resource development in Western Newfoundland. Many aspects of these questions are addressed elsewhere in the material presented in the final report of the Newfoundland and Labrador Hydraulic Fracture Review Panel, of which this report is but one of many studies and assessments by qualified professionals. Information on energy policy, existing regulatory framework, geological studies, and so on, can be found on provincial websites, in the scientific literature, and in reports commissioned by other Canadian provinces, or other agencies in the world looking at similar questions. In general, when accessing information on these issues, it is wise to avoid information promoted by special interest groups, either proponents or opponents.

The Shale Gas and Shale Oil Revolutions in North America

Technology in the O&G industry in North America changed very rapidly in the period 2004-2014, and continues to evolve. In the first five years of this century, drilling long horizontal wells and performing HF stimulations at multiple locations along them was perfected during development of natural gas resources in Texas.⁴ This natural gas play, called the Barnett Shale play, was the first resource base to be accessed in this way at a large scale, and the demonstration of new technology to unlock previously non-commercial accumulations of gas triggered a massive increase in drilling and production activity in similar shale deposits in the USA and Canada. This period is now referred to as the "Shale Gas Revolution".⁵ Soon, the O&G industry realized that substantial light oil resources were locked in low-permeability shale strata, and the "Shale Oil Revolution" took off around 2010. In the period 2009-2015, oil production in the USA increased by approximately 4.5 MMb/d (Figure 4). In the history of the world oil industry, this has been an unprecedented pace of production increase, unequalled in any country previously, and driven by both technology development and high prices. By the end of 2015, following a world-wide price collapse in 2014-2015 from about \$US95/b to less than \$US40/b, American oil production had levelled off at somewhat less than 10 MMb/d and begun to slowly decline.

This surge in USA production from 2008-2009 to mid-2015, slightly preceded by the surge in natural gas drilling and production (visit EIA web site for full USA information over time – www.eia.gov), was not anticipated by economists, policy analysts,⁶ regulatory agencies, or state governments. A few visionaries who studied and understood the potential impact of development and implementation of new technologies for drilling and fracturing foresaw both

² Rivard C., Lavoie D., Lefebvre R., Séjourné S., Lamontagne C., Duchesne M. 2014. An overview of Canadian shale gas production and environmental concerns. *International Journal of Coal Geology* **126**, 64-76.

³ www.nrcan.gc.ca/publications/1138

⁴ Trembath A., Jenkins J., Nordhaus T., Shellenberger M. 2012. *Where the Shale Gas Revolution Came From: Government's role in the development of hydraulic fracturing in shale*. Breakthrough Institute, Energy & Climate Program, 13 p, thebreakthrough.org/energy.shtml

⁵ Wang Q., Xi C., Jha A.N., Rogers H., 2014. Natural gas from shale formation – The evolution, evidences and challenges of shale gas revolution in United States. *Renewable and Sustainable Energy Reviews* **30**, 1-28.

⁶ Greene D.L., Hopson J.L., Jia Li. 2006. Have we run out of oil yet? Oil peaking analysis from an optimist's perspective. *Energy Policy* **34(5)**, 515-531.

the production surge and the recent price collapse,⁷ but in general governments were not prepared for the rate of increase in drilling and hydraulic fracturing activity. Nor did industry or governments foresee the price collapse of 2014-2015 that was, at least in part, triggered by the sudden increase in USA domestic oil production.

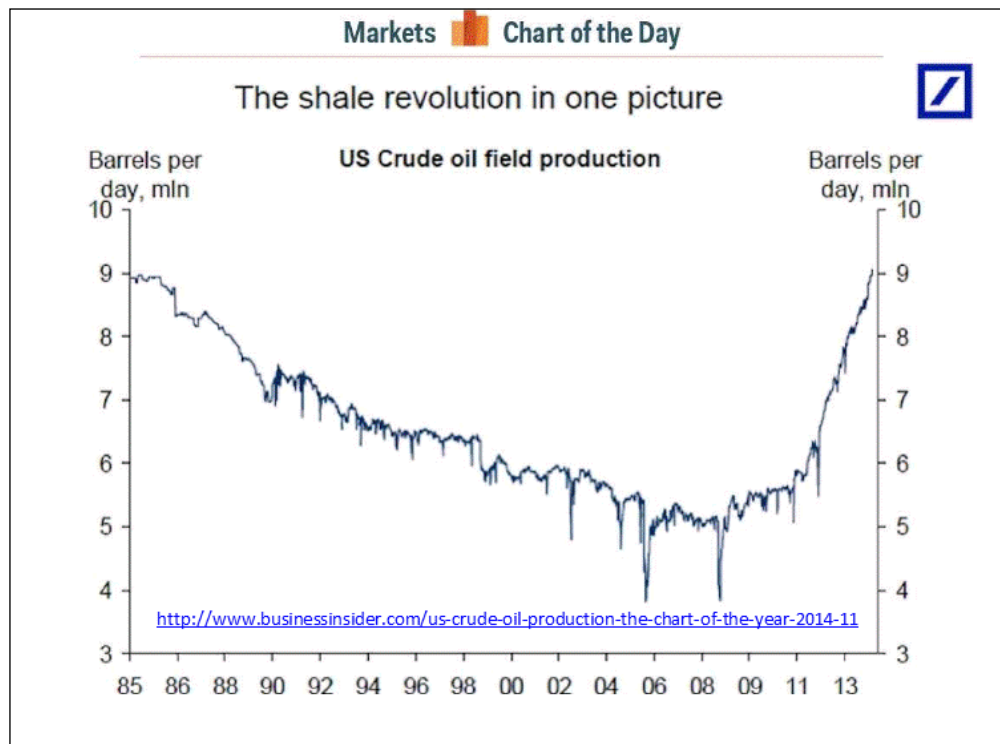

Figure 4. Increase of US oil production because of new technologies applied to shale oil. (Data source: eia.gov)

State regulatory agencies in the USA became more active in promulgating appropriate rules and practices to deal with the surge in drilling, hydraulic fracturing and production. The local pace of resource development sometimes increased so rapidly in regions unprepared to cope with a rapid industrial surge (North Dakota for shale oil, Pennsylvania for shale gas in particular) that problems arose such as a sudden worker influx and infrastructure demands. Some environmentally suspect decisions were made, such as permitting massive flaring of excess and unmarketable natural gas (North Dakota), or allowing the temporary placement of potentially hazardous fracture flowback fluids in lined lagoons (Pennsylvania) which have a poor track record in fully retaining such fluids

The unexpected surge of drilling and HF activity in regions that had previously experienced little recent O&G development triggered a dramatic surge in public concern, exacerbated initially by a somewhat dismissive and patronizing attitude by industry,⁸ as well as by silence or timid responses on the part of the beleaguered and ill-prepared regulatory bodies.⁹

⁷ Maugeri L. 2012. Oil: The Next Revolution. The unprecedented upsurge of oil production capacity and what it means for the world. Geopolitics of Energy Project, Belfer Center for Science and International Affairs, John F. Kennedy School of Government, Harvard University, *Discussion Paper #2012-10*, 75 p

⁸ Prud'homme A. 2014. *Hydrofracking: What Everyone Needs to Know*. Oxford University Press, New York NY, xvii + 184 p. ISBN 978-0-19-931125-5

⁹ Wiseman H.J. 2009. Untested Waters: The Rise of Hydraulic Fracturing in Oil and Gas Production and the Need to Revisit Regulation. *Fordham Environmental Law Review* **20**, p 115ff, ssrn.com/abstract=1595092

Triggered by the development scale and the public response, scientific studies were initiated, focusing on potential environmental hazards of rapid O&G development. Many studies, referred to in the following pages, focused on identifying and quantifying environmental and health risks, as that is the nature of this branch of science. Sociological studies were undertaken to try and understand the basis of the opposition to hydraulic fracturing and shale gas development.^{10,11} Now, fully 10 years after the onset of the shale gas revolution, broad reviews of regulatory issues and environmental impacts are beginning to emerge¹² for areas such as Pennsylvania, which had to cope with an exceptionally rapid surge in drilling and HF activity without a sufficiently developed regulatory environment.

Some useful and reputable sources of information are listed here, most of them American because 90% of the world's shale gas and shale oil development to date has taken place in the USA.

- The United States Department of Energy¹³ and subsidiary agencies including the National Energy Technology Laboratories¹⁴ and the Energy Information Agency¹⁵ are reliable sources of data, studies, and scientific articles.
- The United States Department of the Interior and its subsidiaries such as the US Geological Survey (USGS)¹⁶ publish studies on aspects of shale oil and shale gas, from resource delineation to environmental impact (groundwater base studies, methane issues, induced seismicity).
- NOAA, the National Oceanographic and Atmospheric Administration¹⁷ of the United States Department of Commerce has published work on methane emissions and detection, related to O&G development, among many other related subjects.
- Natural Resources Canada (NRCan)¹⁸ and its subsidiary agency the Geological Survey of Canada (GSC)¹⁹ publish shale oil and shale gas information and support studies related to various issues of an environmental nature related to resource development.
- The National Energy Board²⁰ is an independent federal regulatory tribunal that regulates energy development on federal land, assesses interprovincial and federal issues and projects, including evaluation of pipelines, exports of fossil fuel, and so on. It publishes detailed national data on oil and gas production by province.
- Provincial regulatory agencies in Canada are repositories of vast amounts of useful information including individual well production data over time, geoscience studies, and many documents related to energy project applications, regulatory guideline development, and management of the energy sector on behalf of the citizens of each province. The website for Alberta²¹ is by far the most detailed because the majority of Canada's O&G activity has taken place in Alberta, and the Alberta Energy Regulator is world-known for its regulatory sophistication.

¹⁰ Boudet H., Clarke C., Bugden D., Maibach E., Roser-Renouf C., Leiserowitz A. 2013. "Fracking" controversy and communication: Using national survey data to understand public perceptions of hydraulic fracturing. *Energy Policy* 65, 57-67

¹¹ Dyos-Hunter, C. 2014. Analysis of the Media Representation of Hydraulic Fracturing in UK Print Media 2011-2013. 40 p (Sent to the Newfoundland and Labrador Hydraulic Fracture Review Panel and posted on the website nlhfrp.ca/)

¹² Brantley S.L., Yoxtheimer D., Arjmand S., Grieve P., Vidic R., Pollak J., Llewellyn G.T., Abadb J., Simon C. 2014. Water resource impacts during unconventional shale gas development: The Pennsylvania experience. *International Journal of Coal Geology* 126, 140-156

¹³ There are many sites on the US DoE webpages that provide useful information, including pages dedicated to shale gas issues such as energy.gov/fe/science-innovation/oil-gas-research/shale-gas-rd

¹⁴ www.netl.doe.gov/

¹⁵ www.eia.gov/

¹⁶ www.usgs.gov/

¹⁷ www.noaa.gov/

¹⁸ www.nrcan.gc.ca/home

¹⁹ www.nrcan.gc.ca/earth-sciences/science/geology/gsc/17100

²⁰ www.neb-one.gc.ca/index-eng.html

²¹ www.aer.ca/

- Other valuable Canadian regulatory agency sites include the British Columbia²² and Québec webpages. The latter is recommended because a year-long detailed study of the technical, environmental, socio-economical and transport issues related to potential hydrocarbon development on Anticosti Island has recently been published.²³ Given similar climates, proximity to the waters of the Gulf of St Lawrence, and many other issues, the studies published at that website have singular relevance to the issue of possible development of shale oil resources in Western Newfoundland.
- The British Geological Survey,²⁴ has published studies related to shale gas issues in Britain.

This list is not intended to be exhaustive, and in general it does not contain assessments of public health issues related to O&G development. However, the studies that can be accessed through these agencies are reputable, factual, and not ideologically driven. The reader is again cautioned to be extremely suspicious of seemingly scientific claims presented by various websites that represent lobby groups with positions either for or against O&G development, or that seek to promote a specific world view. Such sites present carefully selected facts, unsubstantiated claims, and sometimes simply false information, and do not pass the test of scientific verification for veracity and dispassionate analysis.

Risk

No human activity is without risk. All industrial developments carry an array of risks and benefits. The individuals responsible for a development, including the engineers and geoscientists who through licensure and legislation are expected to perform their work with a high degree of competence and ethics, have to identify the risks, delineate the probabilities and the consequences, and seek to mitigate the consequences and reduce the probabilities, as much as is reasonably achievable.

Experts differentiate clearly between personal risk and general risk.²⁵ A good example of an intensely personal decision engendering personal risk is driving one's vehicle on a road. Everyone is aware of the risks, as fatalities and accidents are widely published, and safe driving programs are promoted on various media outlets. Individuals intuitively believe that they can adequately "manage the risk" of driving; therefore, except perhaps in extreme weather conditions, individual drivers rarely think about risk. A general risk is, for example, the risk of pollution of a watercourse from the failure of a containment structure such as a pulp-and-paper mill pond or a mine tailings pond. In this case, individuals have no control over the risks to which they may be exposed, and therefore a much lower perceived risk level is tolerated.

The word "risk" is an emotionally charged word, used and abused repeatedly in the media and internet discourse in ways that polarize discussions and create antagonism. This section seeks to clarify the meaning of the term "risk" in an engineering or industrial context, but many definitions exist that are slightly different.

As an example, the website www.businessdictionary.com/definition/risk.html#ixzz3mIYM9UKz gives six definitions of risk; the first and broadest is:

"A probability or threat of damage, injury, liability, loss, or any other negative occurrence that is caused by external or internal vulnerabilities, and that may be avoided through preemptive action."

²² www.aer.ca/

²³ hydrocarbures.gouv.qc.ca/

²⁴ www.bgs.ac.uk/shalegas/

²⁵ Sjöberg L. 2003. The Different Dynamics of Personal and General Risk. *Risk Management* 5, 19-34.

Hence, a risk is defined as:

- a potential for a negative outcome
- being related to vulnerabilities that can be identified
- capable of being avoided (or mitigated)

Other definitions of risk are subtly different, but this definition associates risk with probabilities, consequences, and an ability to be mitigated, and is therefore quite comprehensive. Some argue that presenting risk entirely in negative terms is inappropriate, and accordingly the term “upside risk” is often used to describe the positive outcomes (or potential benefits) of an activity or a development program. The term “opportunity risk” is different; it refers to the opportunity (or benefits) lost by investment in one area at the expense of another, and this is used to refer, for example, to potentially lower long-term benefits from investing in one energy source (e.g. natural gas) compared to another (e.g. solar power).

Natural resource development brings benefits of various kinds to societies; the current economic strength and quality of life in Newfoundland and Canada were established in large part on the basis of natural resource development that permitted economic growth into other domains such as manufacturing and services. However, discussions of potential risks associated with drilling, HF and wellbore integrity rarely include an assessment of the benefits of resource development. These “risk assessments” almost invariably focus on the potential negative risks involved, usually environmental and public health risks, and how these arise and might be mitigated. The positive aspects (benefits) of resource development are discussed in generic terms in NL government information²⁶ and have been the subject of conferences²⁷ and industry-funded studies²⁸.

It is important to remember that, even in the scientific and technical literature that has been independently vetted, there are differences in interpretation and impact assessment, especially in the area of environmental and public health risks associated with HF and related activities. The reasons for this are numerous, but part of the challenge in arriving at a scientific consensus on issues such as risk to groundwater quality and public health impacts may lie in a lack of detailed studies over a sufficient time frame to allow reasonable assessments to be made. This may be the case with new chemicals introduced into the biosphere, for example, but is generally not the case for naturally occurring materials such as arsenic in groundwater (toxic in low concentrations²⁹) or methane in groundwater (not toxic³⁰), as these issues have been broadly studied for decades. There may be insufficient baseline data for comparison, so persons in positions of authority may take a conservative approach, recommending further assessments of a risk. A good example is seismic risk in Western Newfoundland: more data are probably needed to establish baseline natural seismicity and natural stress conditions before any realistic predictions could be made. This was the case in New Brunswick, so the New Brunswick Energy Institute commissioned the Geological Survey of Canada to establish additional regional seismometers to allow more precise data to be gathered in south central New Brunswick before any significant O&G development activity might take place.³¹

Another issue leading to difficulties in making rational and carefully weighed assessments of risk is that different persons, even scientists, have individual perceptions of consequences that can differ widely. This often seems to

²⁶ Premier’s Advisory Council on the Economy and Technology, November 1998. Principles for Enhancing Provincial Benefits for the Natural Resource Sector. An Industry/Government Partnership. www.gov.nl.ca/publicat/benefitsreport.htm

²⁷ Carter, A. 2007. Economic Development Benefits of the Oil and Gas Industry In Newfoundland and Labrador. Summary of a Conference sponsored by The Leslie Harris Centre of Regional Policy and Development, Memorial University of Newfoundland. 47 p. www.mun.ca/harriscentre/reports/research/2007/HC_-_OG_Conference_Report.pdf

²⁸ Stantec Engineering. 2012. Socio-Economic Benefits From Petroleum Industry Activity in Newfoundland and Labrador, 2008-2010. Prepared for Petroleum Research Newfoundland and Labrador Final Report, File No. 121510802, 41 p. [www.petroleumresearch.ca/files/files/PRNL%20Socio-Economic%20Benefits%20Report%20-%202012JUNE05\(1\).pdf](http://www.petroleumresearch.ca/files/files/PRNL%20Socio-Economic%20Benefits%20Report%20-%202012JUNE05(1).pdf)

²⁹ www.who.int/mediacentre/factsheets/fs372/en/

³⁰ environment.gov.ab.ca/info/library/8079.pdf

³¹ nbenergyinstitute.ca/energy-science/ongoing

be the case in assessments of the impacts of domestic water well contamination by methane. Because domestic water wells in Canada are often naturally contaminated by methane from deep subsurface sources or from local decomposition of organic matter,^{32,33,34,35} demonstrating unequivocally that domestic water well contamination from O&G activity is occurring in any area under development is difficult. This is especially so if there are only a few isolated cases of such contamination within a large number of domestic water wells, many of which are already naturally contaminated by deep methane sources. Methane itself has no known toxicity and is bacteriologically degraded in aquifers, although the degradation products in shallow aquifers may in some cases cause a reduction in water quality through reactions that give an odor of sulphur.³⁶

From study of the literature, it appears that the probability of methane from O&G wells entering domestic water sources is not zero, but it is small. The specific probability is difficult to estimate because of a lack of systematic regional studies, but it is also known that the consequences of groundwater methane contamination on public health are also small; this should lead to an assessment of low overall risk. However, the grey literature sourced from opponents to O&G development often takes a position that the risks associated with methane contamination are insufficiently understood, high, or even severe, and single incidents are wildly exaggerated. Some proponent websites, on the other hand, state that there are no risks of groundwater contamination with modern technology, a claim that is equally and demonstrably false. The objective truth lies between these extreme views and can be quantified by appropriate programs of baseline data collection (e.g. baseline methane occurrence studies taking place in New Brunswick³⁷) and monitoring for changes during O&G development. In the case of methane in O&G development areas, few in-depth studies have been carried out, likely because methane occurs naturally in water wells in O&G areas, because of the non-toxic nature of methane, and because of a perception of only slight possibility of enhanced methane contamination from O&G activity.

The origin of contamination of shallow groundwater is often misunderstood, so the risks involved are also misunderstood. By far the most common pathway for contamination is from the surface to the groundwater via spills, leaks, transportation accidents, and so on.³⁸ Although occurrences of contamination associated with O&G activity are well-known, such occurrences are also extremely well known for a range of other industries. Recognition of the impacts of surface spills on groundwater and the environment has led, for example, to extensive regulations and enforcement activities on the chemicals industry and the transportation sector, well-understood sources of groundwater contamination risk. Means of quantifying these risks are well established because transportation accidents or chemical plant accidents are well documented. Furthermore, methods of mitigating the risks in transportation and on industrial sites are well understood. In the case of transportation risks, mitigative measures may include time windows for transportation, special routes, conveying of trucks, conversion to train or pipeline transport, special tanker truck designs, speed control, and so on.³⁹

³² Kennedy G.W, Drage J.M. 2015. Assessing patterns of dissolved methane in shallow aquifers related to Carboniferous and Triassic sedimentary basins, Nova Scotia, Canada. *Atlantic Geology* **51**, 233-241. journals.lib.unb.ca/index.php/ag/article/view/22366

³³ Al T.A., Leblanc J., Phillips S. 2013. A Study of Groundwater Quality from Domestic Wells in the Sussex and Elgin Regions, New Brunswick: With Comparison to Deep Formation Water and Gas from the McCully Gas Field. *Geological Survey of Canada Open File Report 7449*, 40 p

³⁴ McIntosh J.C., Grasby S.E., Hamilton S.M., Osborn S.G. 2014. Origin, distribution and hydrogeochemical controls on methane occurrences in shallow aquifers, southwestern Ontario, Canada. *Applied Geochemistry* **50**, 37-52.

³⁵ Skuce M., Longstaffe F.J., Carter T.R. Potter J. 2015. Isotopic fingerprinting of groundwaters in southwestern Ontario: Applications to abandoned well remediation. *Applied Geochemistry* **58**, 1-13.

³⁶ Van Stempvoort, D., H. Maathuis, E. Jaworski, B. Mayer, and K. Rich. 2005. Oxidation of Fugitive Methane in Ground Water Linked to Bacterial Sulfate Reduction. *Ground Water* **43(2)**, 187-199.

³⁷ nbenergyinstitute.ca/energy-science/ongoing

³⁸ Drollette B.D., Hoelzer K., Warner N.R., Darrah T.H., Karatum O., O'Connor M.P., Nelson R.K., Fernandez L.A., Reddy C.M., Vengosh A., Jackson R.B., Elsner M., Plata D.L. 2015. Elevated levels of diesel range organic compounds in groundwater near Marcellus gas operations are derived from surface activities. *Proceedings of the National Academy of Sciences* **112(43)**, 13184-13189

³⁹ GLC (Great Lakes Commission). 2015. Crude Oil Transport: Risks and Impacts. Issue Brief 3 (13 p) in: *Issues and Trends Surrounding the Movement of Crude Oil in the Great Lakes-St. Lawrence River Region*, glc.org/projects/water-quality/oil-transport/

In engineering terms, risk is viewed somewhat more narrowly as the combination of the probability (chances of occurrence) of an event and the consequences (impact or negative outcomes) of the event. In the context of potential O&G development in Western Newfoundland, several examples or general risk evaluation (non-quantitative) are given here.

- In the Port au Port Bay region, environmental risks are mainly related to the potential contamination of water sources as the result of surface spills during transportation and storage. That being said, because aquifers appear to be local, somewhat isolated, and draining to the sea (only the periphery coastline of the Port au Port Peninsula is significantly populated), an event such as a spill at one location is less likely to contaminate a large number of water wells than a spill in a flat area such as the St Lawrence Lowlands in Québec. Hence the human health and safety consequences of an event such as a spill are likely to be more manageable, in comparison, and mitigation and clean-up activities more easily achieved.
- In some regions such as Alberta, where there exist over 450,000 energy wells, the probability of a HF operation in one well intersecting an existing offset well is small but not zero, and one such documented event that led to a surface spill is well-known⁴⁰ (Innisfail, AB, Jan 13 2012). Apparently, this is the only known event in Alberta where surface efflux of HF fluids took place, and this event has led to new Guidelines for energy companies to follow during well stimulation so that the risks are reduced. In Western Newfoundland, only a few wells exist, and many of these are shallow and do not penetrate to the depths at which HF might take place (>1000 m deep). Hence, the probability of such an event taking place in Western Newfoundland is extremely remote.
- HF in Western Newfoundland will certainly generate large numbers of small earthquakes, perhaps some of them within the range of human detection. However, if these are not felt by the region's inhabitants, the consequences are negligible, and even if the events are large enough to be felt, the risk to infrastructure is likely to be negligible because no sensitive infrastructure exists or is likely to be constructed, and the magnitude of the largest events will be below any damage threshold. (Refer to the study by D. Eaton which is part of this assessment, where he advises quantification of the current seismic activity state with an enhanced seismic array before large-scale HF takes place.)
- Although the probability of a chemical spill at a shale oil development site is very likely if there are many sites occupied over several decades, these sites are currently viewed to be shoreline sites situated away from communities. Groundwater drainage is almost always down-slope toward the sea or the Bay, and therefore the consequences of such an event would be far less than if the groundwater flow were toward an inhabited area. Furthermore, in these near-coastal regions of Western Newfoundland, the potable groundwater systems are local and isolated one from the other, in contrast to wide-spread regional aquifers like in the Canadian Prairies; hence, even if a spill occurs, the impacts are much more local, isolated, and therefore manageable. The consequences are less, so the risk is less.

All such examples of risk entail the concepts of the **probability of an event and consequences of an event**. In science and engineering, if something is physically possible, the risk cannot be said to be zero, even if the risk is infinitesimally small. Failure of the casual user of the word "risk" to appreciate the concept of the probability of an event, or of the consequences of an event should it occur, often leads to misleading or erroneous perception; discourse, dialogue and diagnosis suffer as a consequence. The scientist or professional engineer will readily admit that risks of a technical nature cannot be reduced to zero, but they usually can be reduced to very low values, from either or both aspects of probability and consequence, for almost all industrial processes.

⁴⁰ ERCB – Energy Resources Conservation Board (now AER – Alberta Energy Regulator). 2012. Midway Energy Ltd. Hydraulic Fracturing Incident: Interwellbore communication Jan 13 2012. ERCB Investigation Report. 11p (www.aer.ca)

In this discussion, “risk” is associated with the probability of an event occurring as well as the magnitude of the negative consequence attending such an event. This concept is often presented as a simple non-quantitative equation:

$$R = P \times C \text{ – Risk equals Probability times (negative) Consequences}$$

In many cases, risk must be expressed semi-quantitatively (statistical probability of a storm of a certain intensity...), or in a relative manner (more than..., much less than...). In the examples above, it is suggested that the risk of a spill is less in the Port au Port Bay area than in many other areas because the consequences of an event would be isolated and more manageable. Engineering risk analysis seeks to quantify risk as much as possible in terms not only of the probability of an event in time and in space, but also the probability of a particular level of consequences. This concept is well understood in earthquake engineering, where the **probability** of an event of a certain magnitude over a period of time (say 30 years) can be expressed as a fractional number or percentage: “There is a 30% probability ($P = 0.30$) of an earthquake of moment magnitude 5.0 or larger in a specified region over the next 10 years.” Or, for a rainfall event: “There is a 5% probability in any single year of a 24-hour rain event exceeding 5 cm of rainfall (in a specified region).” Note that these probabilities are not risks, as they say nothing about the consequences. A magnitude 5.0 earthquake in Western Newfoundland would have far lower consequences than if it had occurred under the city of Montreal, therefore the risks are far less.

The **consequences** of such an event are more difficult to specify, but statements such as the following can be made if reasonable data are available: “It is estimated that there is a 50% probability of flood damage of \$5 million if 5 cm of rain falls in a 24 hour period. However, the risk to life is estimated to be small, with less than a 10% probability of the loss of a single life as a direct consequence of flooding.” This type of quantitative risk analysis can be used by communities and governments to make decisions about infrastructure investments, and in the case of potential industrial developments, assessments of the impacts that might ensue. Public health risk assessment is an important task, and nowadays all major projects such as oil and gas development in a new region are accompanied by an evaluation of the consequences of the project; this leads to a need to understand and assess both negative and positive outcomes.

Risk quantification and the communication of risk to the public is a challenging task, made more so when trying to balance risks in one domain with benefits in another (e.g. increased risk of local road accidents but an improved air ambulance service as part of new infrastructure). For example, excellent scientific articles often focus on determining the probability of a negative event taking place (such as a spill of HF chemicals), but do not, in the same article, discuss the socioeconomic positive aspects of developing a resource such as oil or gas (better employment, better medical care system and health outcomes, new infrastructure...).

It is possible to rank risks semi-quantitatively and comparatively on the two axes of **probability** and **consequences**. Figure 5 shows how this is done. First, one should note that the scales are not linear scales, they are approximately logarithmic scales. Also, the probability scale has to be further defined, such as the probability of a particular event in a year, or the probability of a fatal accident for distance driven, and so on. Clearly, on the left-hand side, the probability of an event occurring (e.g. in a given year) is not zero, but it is very small indeed. In contrast, on the right-hand side, the probability is so large as to be almost certain. On the right-hand side, the probability is perhaps 1000 or even 100,000 times greater than on the left hand side, depending on what type of events are being discussed.

For example, a rainfall event exceeding 25 cm of rain in one day would be an improbable event in any given year, albeit with severe infrastructure damage if it hit a city such as St. John’s, but far less severe consequences if the event were restricted to the Northern Peninsula (low population, little infrastructure). The risk for St. John’s, if such a rainfall would overwhelm the storm sewer system, might plot in the upper left-hand quadrant, close to the letter A perhaps. However, a rainfall event of 4 to 8 centimeters in a single day is common each year in St. John’s, and the consequences are minor because the City drainage systems are well-equipped to handle such common events; hence, the risk would plot in the lower right-hand quadrant, perhaps close to the letter B.

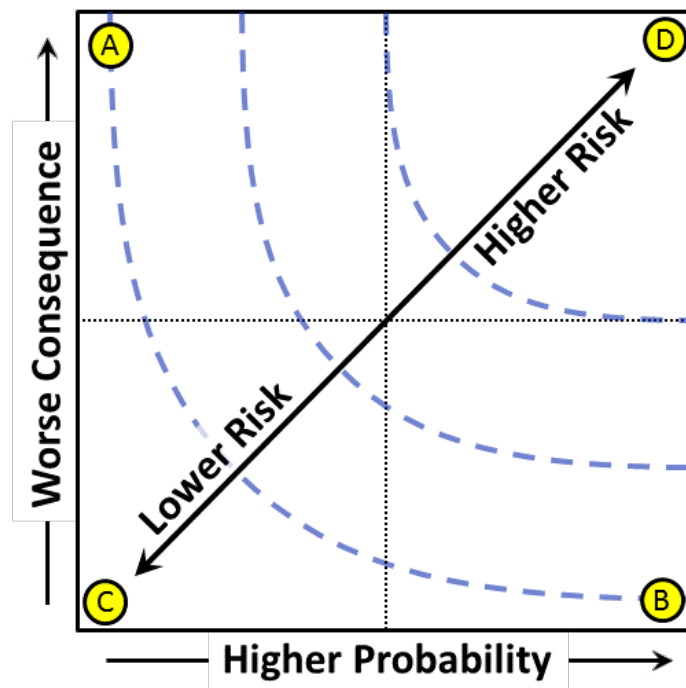

Figure 5. A plot of probability vs. consequences helps quantify relative risk.

Events plotting in the upper right-hand corner, near D, must be carefully studied so that risks can be reduced through making the consequences less severe (e.g. airbags in cars), or reducing the probability of the event (e.g. safer highways). In contrast, events in the lower left-hand corner, near C, may be realistically set aside so that engineering activities can focus on issues of greater risk. The dotted blue lines may be viewed, in an approximate sense, as lines of equal risk.

Risk Perception, Acceptability, Mitigation and Economic Impact

The concept that industry must somehow eliminate all risk before venturing forward is inappropriate because it is impossible. For example, demanding that there be no risk of a pipeline rupture is an unrealistic position; it is far more realistic to demand that the pipeline rupture risks (both probability and consequences) be reduced to the point where they are so small that they are outweighed by the benefits of the project. Hence, what must be done if development is to be undertaken in Western Newfoundland is to encourage or mandate the investment of time, procedures and technology to reduce the risk to a level that is commensurate with the expectations of the resource owner (the people of Newfoundland through their different levels of government) and so that there is public confidence in proceeding with development. Such investment in risk reduction bears attendant costs (at least short-term costs). If at some level such costs are so onerous as to threaten the profitability of resource development, corporations will not invest. Similarly, if extreme measures are taken to eliminate risk by banning some activities that are deemed necessary to develop the resource, such as an official moratorium on the use of local water sources for HF, then the corporation will deem that there is no "path to profits", and will not undertake further investment in developing that resource.

Recent moratoria on hydraulic fracturing in Nova Scotia (2014) and New Brunswick (2014), and the pause on accepting applications for hydraulic fracturing in Newfoundland (2013), have led to a substantial diminution of investments, and this also means that data generated from quantitative studies to support these investments that would allow a more quantitative risk evaluation of HC [hydrocarbon] development are no longer being collected in those jurisdictions. This makes the assessment process more lengthy, complex, costly, and with a greater level of uncertainty. In all engineering endeavours, there is a significant level of uncertainty before development actually starts, therefore risk predictions will reflect this uncertainty, and the steps needed to manage risks will remain somewhat ill-defined until development actually begins and the collection of appropriate data is initiated.⁴¹ This has led to the concept of “adaptive management” of projects,⁴² where continual design improvement and risk reduction are part of the construction and operations activities.

One important aspect of project development is that of “risk perception”. This perception can be related to personal risk (methane entering personal well water), or to general risk (methane as a greenhouse gas and climate change agent). In the Maritimes, perceived risks associated with onshore O&G activities were large in the period 2011-2015. Even after several expert panels^{43,44} came to the conclusion that the risks associated with HF and O&G development were reasonably well understood and were manageable, and therefore advised to “go forward but go slowly and carefully”, the public perception of risk remained high. The Nova Scotia government declared a moratorium in August of 2014 and the New Brunswick government soon followed suit because of an election promise made in the early fall of 2014.⁴⁵ It is generally believed that these decisions were based on responses to widespread and public expressions of high perceived risk associated with onshore O&G development using HF methods for shale gas development triggered by the huge surge of activity in places like Pennsylvania and Texas.

In contrast, in Alberta, extensive development of O&G continues apace, with little opposition, and this is associated with a lower level of perceived risk in the population because of the familiarity of many Albertans with the O&G industry, despite some concerns about the level of enforcement of the regulatory guidelines. Clearly, the level of acceptance of the risks of O&G development in Alberta or other provinces that have a familiarity with the industry leads to a different level of “**risk acceptance**”. This may be based on facts related to benefits and negative impacts of development, on dubious claims about how development might proceed, on prolonged experience with development, or even on a personal view that big industry is inherently bad and will invariably run roughshod over the local communities.

Over the entire population of a region, the personal acceptance level is typically extremely wide, ranging from those opposed to any development at any time, to those who wish to move forward rapidly without considering serious baseline studies or detailed assessment. Self-interest will often dictate the risk acceptance level that persons adopt. A person who stands to gain from development (e.g. an owner of gravel trucks) usually adopts a high risk acceptance

⁴¹ Rahm B.G., Riha S.J. 2012. Toward strategic management of shale gas development: Regional, collective impacts on water resources. *Environmental Science & Policy* **17(2)**, 12-23.

⁴² Linkov I., Satterstrom F.K., Kiker G., Batchelor C., Bridges T., Ferguson E. 2012. From comparative risk assessment to multi-criteria decision analysis and adaptive management: Recent developments and applications. *Environment International* 32(8), 1072-1093.

⁴³ Council of Canadian Academies. 2014. Environmental Impacts of Shale Gas Extraction in Canada: Report from The Expert Panel of Harnessing Science and Technology to Understand the Environmental Impacts of Shale Gas Extraction. Retrieved from www.scienceadvice.ca/uploads/eng/assessments%20and%20publications%20and%20news%20releases/shale%20gas/shalegas_fullreporten.pdf

⁴⁴ Atherton F., Bradfield M., Christmas K., Dalton S., Dusseault M., Gagnon G., Hayes B., MacIntosh C., Mauro I., Ritcey R., Wheeler D. 2014. Report of the Nova Scotia Independent Review Panel on Hydraulic Fracturing. Cape Breton University, Sydney, Nova Scotia. Retrieved from: energy.novascotia.ca/sites/default/files/Report%20of%20the%20Nova%20Scotia%20Independent%20Panel%20on%20Hydraulic%20Fracturing.pdf

⁴⁵ Wheeler D., MacGregor M., Atherton F., Christmas K., Dalton S., Dusseault M., Gagnon G., Hayes B., MacIntosh C., Mauro I., Ritcey R. 2015. Hydraulic fracturing – Integrating public participation with an independent review of the risks and benefits. *Energy Policy* **85**, 299-308.

level and becomes a proponent of development. A person who perceives no personal financial benefit (e.g. a retired local home owner) usually adopts a low risk tolerance level and becomes an opponent to development.

The level of risk acceptance in a society or a region will affect the level of risk management or mandated risk mitigation that is promulgated by the regulatory authority. For example, the lower level of risk acceptance in New Brunswick has led to a set of government responses⁴⁶ and recommended regulations more stringent than those in Alberta. However, even the prospect of seismic exploration in New Brunswick (no drilling or fracturing) was met with active opposition⁴⁷ by those whose level of risk acceptance was extremely low. Risk perception and risk acceptance are complex social issues that are largely beyond the scope of technical assessments, lying in the political, human psychology and social domains. Nevertheless, issues such as risk quantification, preparedness, adaptive management and infrastructure investments must be made on the basis of technical data that are verifiable and appropriate to the region.

Risk mitigation (refer to Figure 5) is undertaken by:

- Reducing the probability of an event taking place, such as a tanker road accident leading to a chemical spill of biodiesel (see Figure 6), and
- Reducing the consequences of such an event, such as mandating higher standards of tank construction on transport trucks, or having rapid response and clean-up systems in place.

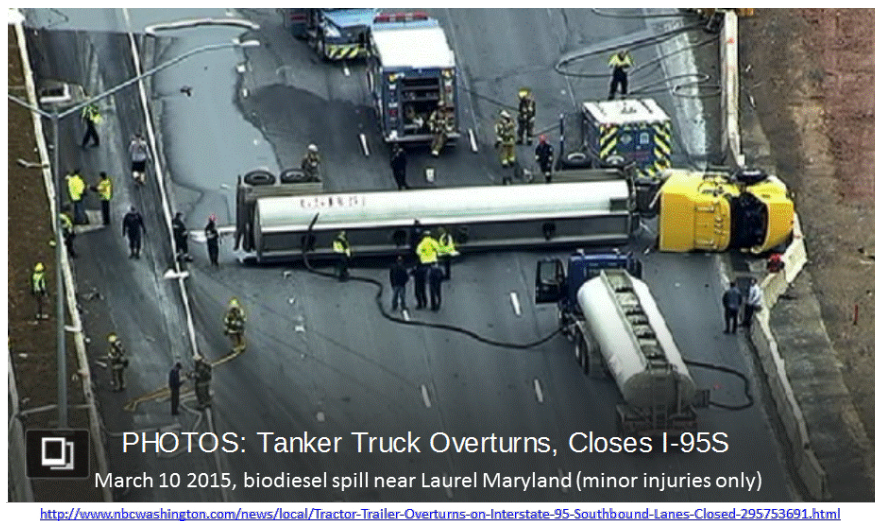

Figure 6. What are acceptable risk levels for tanker trucks on highways?

For each technical risk identified, there are a number of actions that can be taken to reduce these two risk components, in each case with different short-term and long-term economic consequences, and a balance must be sought for these cases. For example, in the case of surface spill risks during O&G development, one might try to balance the real additional cost of improved short-term containment versus the potential cost of long-term contamination and need for rehabilitation. Corporations wanting to develop a HC resource wish to have a clear statement of the risk management requirements from the appropriate regulatory bodies, and they will adhere to these requirements to avoid negative outcomes such as financial penalties, additional mandated actions, bad public relations, or the cancellation of permits. The existence of regulatory requirements and adherence to these minimum

⁴⁶ www2.gnb.ca/content/dam/gnb/Departments/en/pdf/Publications/ONGEnglishFinal.pdf

⁴⁷ news.nationalpost.com/news/canada/new-brunswick-shale-gas-fight-will-continue-chief-vows-criticizing-rcmp-for-horrendous-handling-of-opposition

levels does not absolve a corporation from financial liability in cases of negligence, malpractice, or irresponsible actions, even if the corporation met all the minimum mandated requirements.

This report will look at some risk mitigation actions that could be required by a regulatory agency of corporations undertaking O&G development, although not in an exhaustive manner. As an example, if a regulatory body wishes to reduce the risk of GW contamination from flow-back fluids associated with HF activities, it may prohibit the use of open, lined ponds (Figure 7), and prescribe the use of tanks for the temporary storage of such fluids. The latter is far more costly, but tanks reduce the probability of a spill event, and have been deemed an appropriate requirement for HF in some jurisdictions (depending on the nature of the HF fluids being used).



<http://www.acs.org/content/acs/en/pressroom/presspac/2014/acs-presspac-july-16-2014/another-concern-arises-over-groundwater-contamination-from-fracking-accidents.html>

Figure 7. What are the risks of using lined lagoons vs. tank arrays for hydraulic fracture flow-back fluids?

In general, the management of risks by the O&G industry is a process undertaken through specific engineering actions under the guidelines of the regulatory body, and this involves a cost-benefit analysis. The rules promulgated by O&G regulatory bodies tend more and more to be proscriptive, rather than prescriptive, so that expectations (outcomes) are clearly defined, but the details of procedures to achieve those outcomes are left to the corporations. Success is, in principle, evaluated by the enforcement procedures of the regulatory body (inspections, assessing corporate reports, evaluating complaints...). Corporations are, more and more, being asked to file risk assessment reports including proposed mitigation action to reduce negative consequences before undertaking various types of activities. For large projects, the regulatory agency may ask for a cost estimate for various levels of risk mitigation, along with stipulation of the need to post a bond (purchase an insurance policy) to address unexpected liability. A bond may not affect the probability of an event, but it does cushion the financial and perhaps the environmental consequences of an event, so in that sense it reduces the risk for the society at large.

Development Impacts

Western Newfoundland (Figure 8) in the Port au Port Bay area is a relatively sparsely populated, lightly serviced area used for tourist activities, with insufficient infrastructure at present that could support a significant development of oil and gas production activity.



Figure 8. "Port au Port Group Carbonates Exposed at Cap du Boutte, Port au Port Peninsula." Courtesy www.wnloilandgas.com/energy-west-symposium/archives/2014/field-trip-2014/

Historically the area of Western Newfoundland has supported tourism, commercial fisheries, a pulp and paper industry (still active in Corner Brook), and some mineral extraction activities. The relative importance of these has changed over time, and some fisheries have disappeared, others developed. However, no significant industrial activity has been developed recently.

HC development in the future could take place only with the design and building of substantial infrastructure (ports, roads, drill sites...) and the execution of drilling and production activities within a Newfoundland and Labrador regulatory framework that is yet to be established. However, surface risk management approaches are well-understood and well-regulated in many industrial settings and in the O&G industry by many provinces (BC, AB, SK, MB, ON), and therefore these subjects can be set aside because these jurisdictions are examples of development that has taken place with reasonable benefits and moderate to low negative impacts (there will always be some individuals who are negatively impacted). The regulations in these jurisdictions can be accessed to show how industrial activity on the surface can integrate with local communities, with modifications as necessary for geographical and climatic differences.

The major technical impact issues associated with initial development of an HC resource are those associated with the technology of drilling and HF well stimulation (including materials transportation and storage); however, the major long-term technical impact is that associated with wellbore integrity. The issues related to potential surface and subsurface water contamination from drilling, fracturing and long-term well integrity are the ones most commonly raised as concerns. To understand risks quantitatively, baseline information and technical-scientific assessments must be carried out, as is being done extensively in the St Lawrence Lowlands with respect to the Utica Formation shale gas play.⁴⁸

⁴⁸ Lavoie D., Rivard C., Lefebvre R., Séjourné S., Thériault R., Duchesne M.J., Ahad J.M.E., Wang B., Benoit N., Lamontagne C. 2014. The Utica Shale and gas play in southern Quebec: Geological and hydrogeological syntheses and methodological approaches to groundwater risk evaluation. *International Journal of Coal Geology* **126**, 77-91.

Regulations covering drilling and the management of drilling risks and drilling wastes are extremely well developed areas in the O&G industry everywhere in the world.⁴⁹ Reports carried out elsewhere (see for example the technical dossier of the MERN-ÉES study in Québec⁵⁰) point out that there are no exceptional risks in the possible drilling activity in those areas to access the subsurface HC resources. Handling and disposal of drilling fluids and drill cuttings is the subject of scientific studies⁵¹, with detailed environmental guidelines published in the regulatory literature of various international jurisdictions. For example, drill cuttings and water-base drilling fluids are readily handled by dewatering and landfilling, as long as the drilling fluids are devoid of certain stipulated chemicals that are classified as dangerous to the environment. In such cases, special treatment of waste drilling fluids, or their reuse, are specified by regulations. If special drilling fluids, in particular, non-aqueous drilling fluids, are predicated by the need to avoid damaging the productive formation at depth and to sustain borehole stability during drilling, biodegradable esters can be used instead of other oils that are more persistent and damaging if released on the surface (such as diesel fuel).

At the depths and subsurface conditions found in the Green Point shale around the Port au Port Bay, high performance non-aqueous drilling fluids resistant to high temperatures and pressures will almost certainly not be needed. The potential target strata are on the order of 1 to 3.5 km deep in the Port au Port Bay, locally deformed, and faulted.⁵² There may be mild overpressure in the deepest parts of the Green Point shale and perhaps the directly overlying beds, but because the porosity and permeability of these strata are low, the risk of a severe blowout is negligible. To have a blowout, the source of the high pressure fluid (generally gas) must have a capacity to flow at substantial rates, and shale oil reservoirs, although the oil contains dissolved gas, do not have the flow capacity to generate a sustained blowout.

It is reasonable to assume that, because of the generally low level of risks presented to the activity of drilling in Western Newfoundland, drilling fluids will be more environmentally benign than in other more challenging locations. This subject is therefore also set aside because the risks associated with drilling risks related are thoroughly understood, as are as the methods of mitigating these risks; it is sufficient to adopt a clear proscriptive set of regulatory guidelines because the physical processes and their impacts are well-known, courtesy of extensive activity in other jurisdictions, and because the potential targets in SE Newfoundland do not have extreme pressure, stress and temperature conditions. Figure 9 shows a surmised geological cross-section through the centre of Port au Port Bay (see the NW-SE dashed line in Figure 3, which is the approximate cross-section location for the figure from Hinchey et al. 2015).

Hydraulic Fracture and Risks

HF behaviour is of interest to regulatory entities (resource, environmental and social regulatory agencies), to companies that may develop the Green Point shale, and to the general public who want assurance that the benefits attending development of natural resources are not outweighed by an accumulation of negative impacts. The HF process is an aggressive process of high pressure injection,⁵³ but large volume injection generally only takes place

⁴⁹ Veil J.A. 2002. Drilling Waste Management: Past, Present, and Future. *Proc. SPE Annual Technical Conference and Exhibition*, 29 September-2 October, San Antonio, Texas. SPE-77388, 7 p. dx.doi.org/10.2118/77388-MS

⁵⁰ hydrocarbures.gouv.qc.ca/

⁵¹ Leonard S.A., Stegemann J.A. 2010. Stabilization/solidification of petroleum drill cuttings. *Journal of Hazardous Materials* **174(1-3)**, 463-472.

⁵² Hinchey A.M., Knight I., Kilfoil G., Hicks L. 2015. Geological Overview and Hydrocarbon Potential of Cambrian–Ordovician Strata of the Outer Humber Zone, Western Newfoundland. *Current Research Newfoundland and Labrador Department of Natural Resources Geological Survey, Report 15-1*, 143-171.

⁵³ King, G.E. 2012. Hydraulic fracturing 101: What every representative, environmentalist, regulator, reporter, investor, university researcher, neighbor and engineer should know about estimating frac risk and improving frac performance in unconventional gas and oil wells. *Proc Society of Petroleum Engineers Hydraulic Fracturing Technology Conference*, The Woodlands, TX, **SPE#152596**, 80 pp.

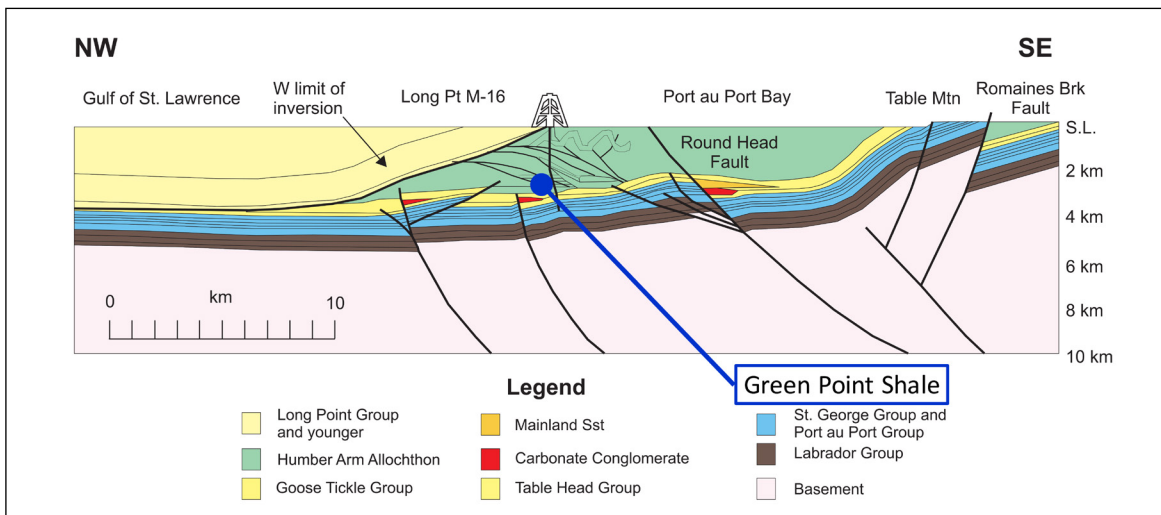

Figure 9. Geological cross-section through the middle of Port au Port Bay, NW to SE (Hinchey et al. 2015). The target Green Point formation is shown by a blue bullet.

at great depth, usually more than 1000 m,⁵⁴ so high pressures and fracturing fluids cannot interact with the shallow GW systems which are generally within 200 m of the surface. Among many potential HF impacts postulated are surface spills of chemicals, or escape to the surface of HF fluids from depth along naturally existing pathways.^{55,56} Many commentary and review articles, such as the Vidic et al. 2013 article referred to in the previous sentence, are somewhat speculative and based on an assessment of what “might happen”, not what is the most probable case from a scientific and experience-driven point-of-view; often the logic is flawed, or the problem is not well understood. Such speculation⁵⁷ is a necessary part of science and technology, but can lead to a distorted perspective of risk because it is a common human reaction to suppose that because something could happen, it will happen, and the consequences would be “catastrophic” or “devastating” (currently, unwarranted hyperbole seems characteristic of social media commentary from both proponents and opponents of resource development). It is also important to note that the proposed development for the Green Point shale is shore to offshore, so that >95% of the length of the horizontal well sections would be offshore. In the extremely unlikely event of sufficient upward migration of HF fluids, they would debouch under the sea in this case, in small quantities, and after having passed through hundreds of metres of strata with minerals that tend to absorb and neutralize chemical agents.

The Myers (2012) article attracted much public and scientific criticism^{58,59} for using unrealistic assumptions and unverified parameters to mathematically simulate a scenario criticised thus: “...these deficiencies are reflective of a model that is unconstrained by reality...” (*ibid.*, p 827). Far fewer articles actually address real data and the mechanisms

⁵⁴ The depth to the top of the Macasty Formation is as little as 400-500 m in the north part of the island. It is most likely that development will occur at depth (>1000 m) for a substantial period of time before more shallow development issues are more clearly understood. Furthermore, the energy in deeper strata is greater because of larger amounts of dissolved gas, and they would be more prospective for that reason.

⁵⁵ Vidic R.D., Brantley S.L., Vandenbossche J.M., Yoxtheimer D., Abad J.D. 2013. Impact of Shale Gas Development on Regional Water Quality. *Science* **340(6134)**, p 826.

⁵⁶ Dusseault, M.B. and Jackson, R. 2014. Seepage pathway assessment for natural gas to shallow groundwater during well stimulation, in production, and after abandonment. *Environmental Geosciences* **21(3)**, 107-126.

⁵⁷ Myers, T. 2012. Potential Contaminant Pathways from Hydraulically Fractured Shale to Aquifers. *Groundwater* **50(6)**, 872-882.

⁵⁸ Cohen H.A., Parratt, T., Andrews C.B. 2013. Discussion of “Potential Contaminant Pathways from Hydraulically Fractured Shale Aquifers,” by T. Myers. Comments in *Groundwater* **51(3)**, 317-319.

⁵⁹ Saiers J.E., Barth E. 2012. Discussion of “Potential Contaminant Pathways from Hydraulically Fractured Shale Aquifers,” by T. Myers. Comments in *Groundwater* **50(6)**, 826-828.

involved in fracturing, although this is becoming more common.⁶⁰ Contamination of GW through spills (from trucks, tanks, pumps) is an uncommon but not rare event in shale oil and shale gas development,⁶¹ but by comparison, contamination of shallow potable groundwater through the rise of deep HF's toward the surface is an exceptionally rare event. It is hard to write scientific articles about events that appear not to have taken place, and it is well recognized by scientists that "absence of evidence is not evidence of absence". Therefore, in a perfectly natural manner, many articles have been published about potential risks of HF, and few articles about the actual quantification of such risks. It does appear that, except for a few cases of intersection of offset wells during active HF operations at high pressures, general post-HF fluid rise through overburden strata to the GW zone has never been confirmed in practice for deep or small-volume fracturing. This report will review some of the commonly held risk concerns, focusing on the deep geo-engineering aspects of HF methods.

Wellbore integrity, an issue recognized decades ago,^{62,63} has come under more and more expert scrutiny, with refereed scientific articles that seem, on the surface, to contradict each other, making the assessment of the environmental impact from the development of a large number of O&G wells (thousands) a challenging task. For example, samples from a large number of domestic supply wells in Pennsylvania in a region of natural gas development by horizontal drilling and MSHF indicated no detectable effect of the industrial development.⁶⁴ Other studies have concluded that O&G development statistically increases the chances of methane occurrences in water supply wells,^{65,66} although the specific sources and pathways were not identified nor studied in the articles referred to. The Osborn et al. (2011) article unleashed commentary, criticisms and consternation from many sources,⁶⁷ making it one of the most criticized scientific articles published on this subject.

Cases of water supply well contamination with chemicals or natural gas have, however, been verified without a doubt. In the case of natural gas detected in water supply wells, it is necessary to make sure that the contamination is the result of the industrial activity and that the gas was not there naturally, or that the chemicals detected were not from some other activity, or that they are present in potentially detectable quantities (analytic chemistry can regularly identify chemical species to parts in a billion). An example of how spurious results can be generated is the identification of cyclic HCs in aquifer water in extremely low concentrations. It might be surmised that such molecules (benzene is the smallest cyclic HC molecule) arrived there through industrial activity such as surface spills, but benzene can be present in small amounts associated with natural gas seepage, as many deep natural gas sources contain trace amounts of cyclic HC molecules. Before conclusive pathway identification is claimed, it is vital to do the necessary high quality sampling and analyses, and even then there may remain some uncertainty about the pathway (see previously referenced article by Drollette et al. 2015).

⁶⁰ Fisher K., Warpinski N. 2012. Hydraulic-fracture-height growth: Real data: Society of Petroleum Engineers *Journal of Production & Operations* **27(1)**, 8-19.

⁶¹ Gross S.A., Avens H.J., Banducci A.M., Sahmel J., Panko J.M., Tvermoes B.E. 2013. Analysis of BTEX groundwater concentrations from surface spills associated with hydraulic fracturing operations. *Journal of the Air & Waste Management Association* **63(4)**, 424-432.

⁶² Harrison S.S. 1985. Contamination of aquifers by overpressuring the annulus of oil and gas wells: *Groundwater*, **23(3)**, 317-324.

⁶³ Dusseault M.B., Gray M.N., Nawrocki P.A. 2000. Why oilwells leak: cement behaviour and long-term consequences. *Proceedings, Society of Petroleum Engineers International Oil and Gas Exhibition*, Beijing, PRC, **SPE #64733**, 8 p.

⁶⁴ Siegel, D.I., Azzolina, N.A., Smith, B.J., Perry, A.E., Bothun, R.L. 2015. Methane Concentrations in Water Wells Unrelated to Proximity to Existing Oil and Gas Wells in Northeastern Pennsylvania. *Environmental Science and Technology* **49**, 4106-4112.

⁶⁵ Jackson, R. B., Vengosh, A., Darrah, T. H., Warner, N. R., Down, A., Poredac, R. J., Osborn, S. G., Zhao, K., Karra, J. D. 2013. Increased stray gas abundance in a subset of drinking water wells near Marcellus shale gas extraction. *Proceedings of the US National Academy of Science* **110**, 11250-11255.

⁶⁶ Osborn, S. G., Vengosh, A., Warner, N. R., Jackson, R. B. 2011. Methane contamination of drinking water accompanying gas-well drilling and hydraulic fracturing. *Proceedings of the US National Academy of Science* **108**, 8172-8176.

⁶⁷ Davies R.J. 2011. Methane contamination of drinking water caused by hydraulic fracturing remains unproven. *Proceedings of the US National Academy of Science* **108(43)**. Comments on paper by Osborne et al. 2011.

Natural gas migration from cased energy wells can be demonstrated using isotopic methods.⁶⁸ Risk evaluation articles exist that outline the potential risk elements in considerable detail.⁶⁹ Baseline studies in various jurisdictions have been initiated to better understand the widespread natural incidence of methane and other constituents in groundwater.^{70,71} For active wells or suspended wells that display integrity problems, methods of identifying and rectifying issues are reasonably well-understood⁷², although issues about cement use and wellbore installation remain.⁷³ This report will amplify on the issues relating to wellbore integrity, inasmuch as these factors have any potential impact on the possible development of HC resources in Western Newfoundland. It is important to keep in mind that natural gas from depth, either shallow sources or deeper sources, is present in aquifers naturally, and shows up in water wells in many regions of Canada.^{74,75}

Geological and Engineering Terms

The word “shale” is used throughout this discussion to refer to fissile and fine-grained deposits with some argillaceous content, typically >33% clay minerals (illite, smectite, kaolinite...). However, many of the “shale oil” and “shale gas” reservoirs being developed in North America do not conform rigorously to this geological definition of “shale” (fissile, fine-grained, clay content >33%, see Figure 10). Many shale gas plays actually take place in fine-grained fissile limestones, mudstones (lacking fissility) or siltstones (low clay content, below 33%). Nevertheless, the term shale is widely used in practice and except when there is a need to be scientifically rigorous, the term “shale” is used.

To avoid confusion, the term “fracture” will be reserved for the features associated with HF stimulation, and the term “joints” will be reserved for the naturally occurring fractures that are found in ancient, stiff fine-grained rocks⁷⁶ such as the Green Point shale of late Cambrian to early Ordovician age in Western Newfoundland. All of the vertical discontinuities in the photos in Figure 10 are joints. The horizontal surfaces visible in the photographs are usually bedding planes associated with the sedimentation processes that generated the fine-grained rocks. These are different than the joints, which tend to be close to 90° to the bedding planes; these joints and “incipient joints” (planes of weakness that are not yet open) were all generated by the processes of diagenesis (compaction and cementation)⁷⁷ and mineral alteration (e.g. smectite-to-illite transition).

⁶⁸ Darrah, T.H., Vengosh, A., Jackson, R.B., Warner, N.R. and Poreda R.J. 2014. Noble gases identify the mechanisms of fugitive gas contamination in drinking-water wells overlying the Marcellus and Barnett Shales. *Proceedings of the US National Academy of Science* **111(39)**, 14076-14081.

⁶⁹ Soeder D.J., Sharma S., Pekney N., Hopkinson L., Dilmore R., Kutchko B., Stewart, B., Carter K., Hakala A., Capo R. 2014. An approach for assessing engineering risk from shale gas wells in the United States. *International Journal of Coal Geology* **126**, 4-19.

⁷⁰ Moritz, A., Hélie, J.F., Pinti, D.L., Larocque, M., Barnette, D., Retailleau, S., Lefebvre, R., Gélinas, Y. 2015. Methane baseline concentrations and sources in shallow aquifers from the shale gas-prone region of the St. Lawrence lowlands (Quebec, Canada). *Environ Science and Technology* **49(7)**, 4765-71.

⁷¹ Molofsky, L.J., Connor, J.A., Wylie, A.S., Wagner, T., Farhat, S.K. 2013. Evaluation of Methane Sources in Groundwater in Northeastern Pennsylvania. *Groundwater* **51(3)**, 333-349.

⁷² Chatellier, J-Y.D., Rioux, R., Molgat, M., Goodall, C. and Smith, R. 2012. Applied Organic Geochemistry and Best Practices to Address a Surface Casing Vent Flow – Lessons from Remediation Work of a Shale Gas Well in Quebec Search and Discovery Article #40976 (2012), Posted July 16, 2012.

⁷³ Oyarhossein M., Dusseault M.B. 2015. Wellbore Stress Changes and Microannulus Development Because of Cement Shrinkage. Proc. 49th American Rock Mechanics Association Conf. San Francisco, Paper ARMA 15-118, 9 p.

⁷⁴ [www1.agric.gov.ab.ca/\\$department/deptdocs.nsf/all/eng9758](http://www1.agric.gov.ab.ca/$department/deptdocs.nsf/all/eng9758)

⁷⁵ Moritz A.M. 2014. *Establishing baseline concentration and $\delta^{13}C$ signature of methane in shallow ground waters of the St. Lawrence Lowlands, QC, Canada: A tool for determining shale gas contamination*. MSc Thesis published by Concordia University, Montreal, 73 pages.

⁷⁶ Pinet N., Brake V., Lavoie D., 2015. Geometry and regional significance of joint sets in the Ordovician-Silurian Anticosti Basin: new insights from fracture mapping; Geological Survey of Canada, *Open File Report 7752*, 25 p. (doi: 10.4095/295982).

⁷⁷ Bowker K.A. 2007. Barnett Shale gas production, Fort Worth Basin: Issues and discussion. *American Association of Petroleum Geologists Bulletin* **91(4)**, 523-533.



Figure 10. All naturally fractured low permeability rocks: but only one shale (upper rh photo).

The abbreviation NFR is used to indicate a Naturally Fractured Rock mass, cut by one or more significant joint sets. In sedimentary rock, there are almost always some bedding plane features or lithological contrast features that were close to horizontal when the strata were deposited; in true shales, the bedding planes impart a strong fissility to the rock, so that it parts easily along the bedding planes. Joints and bedding planes in shale oil strata are not formed by karst processes, although many of the rocks in the regions are carbonate-rich. Once joints and fissures form near the surface, karst develops, and karst features may be noted elsewhere in the geological sequence of strata, and are associated with joint aperture enlargement by carbonate rock dissolution processes that creates more open pathways in the NFR. For example, in Anticosti Island, near-surface carbonate strata show karstic features, but these are not known to exist anywhere near the target formations (the Macasty Formation shale oil target in the Anticosti Basin is upper Ordovician in age, about 20 million years younger than the Green Point shale). Joints in shale display no significant lateral displacement between the two sides of the planar feature, and in general joints were generated during geological times in an orientation perpendicular to the local direction of the least principal compressive stress in the ground (σ_3 or σ_{\min}) at the time of formation. Hence, a joint (open, closed but apparent, or incipient) is approximately a "tensile failure" of the rock, with little to no shear movement component along the joint surface (in contrast to a fault for example). Joints in a NFR can be enhanced and new joint sets created if the rock mass is subjected to folding and faulting during tectonic activity.

"Faults" are through-going shear displacement features of large extent, cutting across strata of various ages, with or without intersection with the sub-Quaternary surface, depending when the fault was last active in geological history. The relative displacement of the rocks on either side of the fault can be large (100's of meters) or modest (meters), and the typical maximum length of a fault will be many kilometers, whereas joints tend to be at a scale of 1-10 m. The relative displacement of the two sides of a fault is evidence of shearing, and this shear displacement took place in response to high pore pressures and large shear stresses that caused the rock to yield in a shearing mode at the time of the fault generation. Thus, the processes that created a fault are inherently different from those that generated most joints: a fault is a failure in shear, at an angle to the directions of the principal stresses; a joint is a failure in tension. For example, using the example of Anticosti Island where the strata are relatively flat-lying and otherwise not

significantly affected by tectonic movement, the dominant structural feature that cuts across the Island from east to west is the Jupiter Fault, apparently mainly a normal fault.⁷⁸ In the vicinity of a large fault, one may expect other important rock fabric features, such as an increased number of joints, higher rock mass permeabilities, and evidence of fluid migration over geological history.

In general, "karst" features are found mainly where meteoric water has been flowing through carbonate-rich strata for thousands of years at a rate sufficient to dissolve large amounts of calcium carbonate, generating a number of characteristic dissolution-controlled features in the rock mass. Paleokarst features are karstic features formed at some previous time when the rocks were near the surface. The rocks were then buried, and the karst features preserved in the rock in some way, such as channels, voids and collapse features in the rock which may or may not be plugged with secondary mineral precipitation. Karst processes can lead to collapse features as subterranean cavities collapse, and even local folding and faulting can develop. Karstic features also form in areas where there is dissolution of deep salt (NaCl) or gypsum ($\text{CaCO}_3 \cdot 2\text{H}_2\text{O}$); one of the more famous paleokarstic areas in Canada stretches from the Northwest Territories south of Great Slave Lake to south western Manitoba. It is a major feature of the geology of the Western Canada Sedimentary Basin and its presence locally has implications on development of oil and gas resources.⁷⁹ Paleokarst features in the region are known from the surface exposed carbonate strata of roughly Ordovician age in Anticosti Island⁸⁰ and in the Mingan Islands in Québec (just north of Anticosti Island). Recent karstic features have been studied in western Newfoundland in the Table Head Ordovician carbonates⁸¹, but recent karst (post-glacial) rarely extends to significant depth. The degree to which paleokarst features in carbonate strata may exist at depth in the Port au Port area is not known, although there is evidence of paleokarst that developed very early in the geological history of strata in the Western Newfoundland area.^{82,83} The impact of paleokarst on the characteristics of deep strata in the region is not known, but the environmental risks of such paleokarstic features in relation to drilling and HF activity are likely to be small.

⁷⁸ Bordet R., Malo M., Kirkwood D. 2010. A structural study of western Anticosti Island, St. Lawrence platform, Québec: a fracture analysis that integrates surface and subsurface structural data. *Bulletin of Canadian Petroleum Geology* **58(1)**, 36-55.

⁷⁹ Schneider C.L., S. Mei S., Haug K., Grobe M. 2014. The Sub-Cretaceous Unconformity and the Devonian Subcrop in the Athabasca Oil Sands Area, Townships 87-99, Ranges 1-13, West of the Fourth Meridian. *AER/AGS Open File Report 2014-07*. Alberta Energy Regulator and Alberta Geological Survey, 32 p

⁸⁰ Desrochers A., James N.P. 1988. Early Paleozoic Surface and Subsurface Paleokarst: Middle Ordovician Carbonates, Mingan Islands, Québec. Chapter 9 in *Paleokarst*. Springer, New York, 183-210 (doi:10.1007/978-1-4612-3748-8_10)

⁸¹ Karolyi, M.S. 1978. *Karst Development in Ordovician Carbonates: Western Platform of Newfoundland*. Thesis submitted in partial fulfillment of the requirements for an MSc. McMaster University, Ontario, 170 pages plus appendices.

⁸² Chow N., James N.P. 1992. Synsedimentary Diagenesis of Cambrian Peritidal Carbonates: Evidence from Hardgrounds and Surface Paleokarst in the Port au Port Group, Western Newfoundland. *Bulletin of Canadian Petroleum Geology* **40(2)**, 115-127.

⁸³ Karst features and caves are reported throughout the carbonate rocks of SW Newfoundland where they are exposed, and some assessment of deeper buried karst features may be found in articles co-authored by Ian Knight, referred to in the References List of Hinchey et al. 2015.

Geological Introduction

The target strata for potential shale oil development in Western Newfoundland are called the Green Point shale. The Green Point shale is the common name for the Green Point Formation, and it is somewhat older than the Macasty Formation in the Anticosti Basin and the Utica Formation in the St Lawrence Lowlands. The Macasty and Utica Formations are in sub-basins that are part of the larger complex called the Appalachian Basin that extends from the northern extent of the St Lawrence Lowlands and the Anticosti Basin in Québec southwest to Ohio and Pennsylvania and further southwest. In the thick sequences in the United States, there may be several important source rocks that contain potentially commercial quantities of gas and light oils, in strata such as the Marcellus Formation and Utica Formation. These two source rocks are being developed at a considerable rate, particularly in Pennsylvania and Ohio, with thousands of wells drilling in the period since 2005.

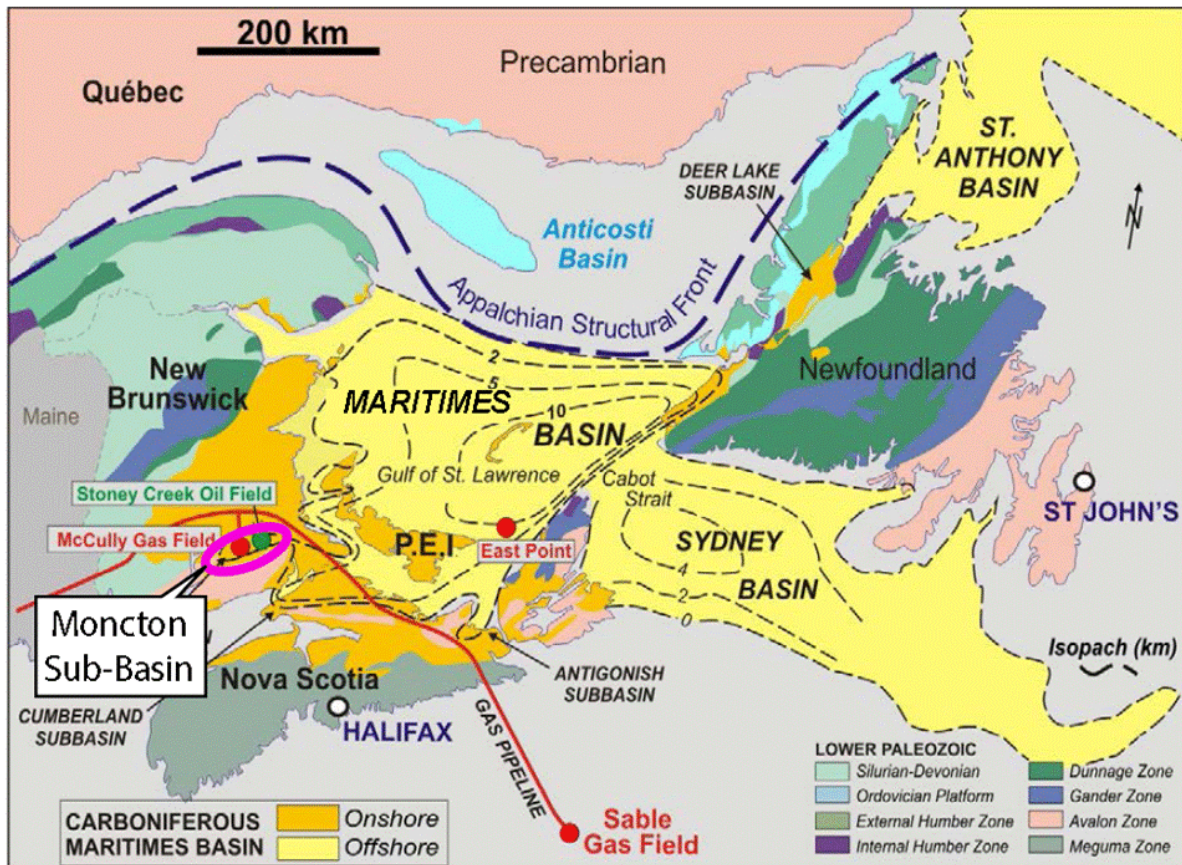

Source: Geological Survey of Canada, 2009 CSPG CSEG CWLS Convention, Canada

JAF21297.AI

Figure 11. The major Paleozoic sedimentary basins of the Atlantic and St. Lawrence regions.

Figure 11 gives information about the broad geological context of the region. The Port au Port region is not explicitly classified as part of the Anticosti Basin nor the Maritimes Basin because it is the lower extent of a zone that was structurally deformed several hundred million years ago, and is referred to in the geological literature as the “western Newfoundland Allochthon”. The word allochthon means a block of rock (generally a sedimentary rock) that is currently situated far from where it was formed. The sedimentary rocks in this zone have been pushed into their current position by tectonic compressive forces (thrust faulting and compression). The overthrust rock units described in the geological works for this region (Hinchey et al. 2015) were pushed toward their present position from the east, and overlie the less deformed rocks below the Green Point shale in the region of the Port au Port Peninsula. The rocks in the allochthonous sequence shown in Figure 9 are therefore folded and deformed, and the degree of folding

and deformation is different at different locations along the western coast where this sequence is observed. In the geological cross-section shown in Figure 9, one may see that the target reservoir zone, the Green Point Formation, underlies the highly folded and distorted strata, and is less distorted and gently inclined, but is not strongly folded nor overturned in this area, in contrast to its outcrop area north of Rocky Harbour several hundred kilometers north east of the Port au Port Peninsula.

So, the Green Point Formation lies in a relatively narrow band of rocks that are found between relatively undeformed basins to the west and north west, and the highly folded and distorted rocks of the Appalachian Mountains to the east and south east. Rocks that were formed at the same time as those in which the Green Point shale are found may be traced from the Northern Peninsula of Newfoundland as far south as Tennessee. In general, they are not highly prospective for oil and gas, compared to the source rocks in the undeformed sections (Utica shale, Marcellus shale, Macasty Formation on Anticosti Island), but the Green Point shale in the Port au Port Bay apparently is prospective enough to have attracted commercial attention. The age of the various source rocks that form the targets being considered for development is similar in other regions around the Gulf of St Lawrence, roughly Ordovician to early Devonian in age.

The Green Point shale lies to the southeast of a strong regional geological feature known as Logan's Line, a major thrust fault front, labeled the Appalachian Structural Front in Figure 11. Logan's Line defines the northwest extent of the Appalachian structurally disturbed zone⁸⁴, and can be traced along the entire front of the Appalachian Mountains from the southeastern United States to western Newfoundland, separating the relatively undeformed strata to the northwest from the structurally deformed and thrust faulted rocks to the southeast. The portions of the Utica and Macasty Formations which are considered prospective for shale gas throughout this region lie to the northwest of Logan's Line, are relatively flat-lying, and have not been subjected to extensive tectonic activity after the sediments were laid down. In contrast, the Green Point shale to the east of Logan's Line has experienced far more deformation (compression, faulting, folding) than the fine-grained source rocks that are being explored or developed for shale gas development in Québec and the United States. This means that using those other geologically well-understood shale gas plays as geological analogues for the Green Point shale is not appropriate, although development schemes and surface impacts would be similar. In other words, the technical aspects of the development of the HC resources in the Appalachian Basin, such as the drilling technology, infrastructure needs, and other social and physical impacts, are highly useful analogues for what development of the Green Point shale might look like, although at a scale many times larger.

Figure 11 also shows the locations of some other oil and gas activity in Paleozoic rocks in the Maritimes Basin (Moncton Subbasin) in New Brunswick. The Stoney Creek Oilfield has been in production since the first decade of the 20th century, and has about a hundred wellbores. Small gas fields are known to exist in the same region, southwest of Moncton, and the thick Frederick Brook shale is highly prospective as a dry natural gas source.

Another regional geological setting that has some geological relationships roughly similar to the Green Point shale is the region of the small-scale oil plays in the Gaspé Peninsula, such as the Galt and the Haldimand Fields. Although these small oil fields are in deformed rocks roughly similar in age and formation to the sediments of western Newfoundland, the oil fields being exploited are not in the source rocks, but small reservoirs where oil accumulated as it migrated from the source rocks. Figure 12 is a general geological map of the region with additional detail. The star in the figure is the Garden Hill "discovery well" drilled at the southwestern tip of the Port au Port Peninsula which produced some oil and gas, and provided proof that potential exists in the region for HC-containing strata to be commercially exploited.

⁸⁴ Lavoie D., Thériault R. 2012. Upper Ordovician shale gas and shale oil in Quebec: Sedimentological, geochemical and thermal frameworks. Extended abstract in *Proceedings GeoConvention 2012*. Calgary AB, 4 p.

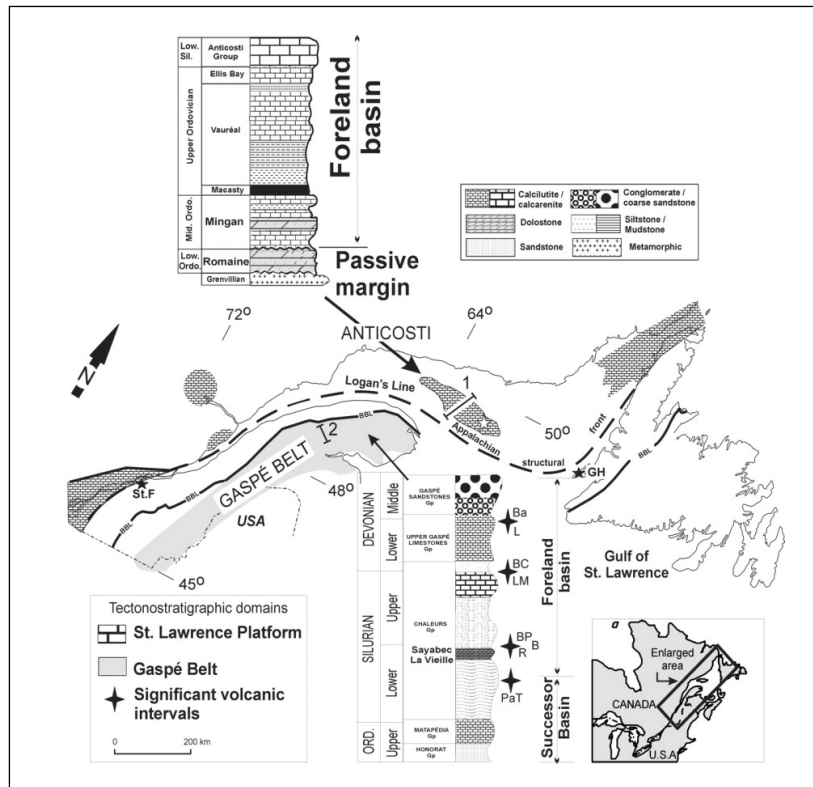

Figure 12. Stratigraphic succession of the Gaspé-Anticosti region.⁸⁵

All of the organic-rich fine-grained rocks that have been identified as major HC source rocks in the St Lawrence Lowlands Basin (Utica Formation), Anticosti Basin (Macasty Formation) and Maritime Basin (Green Point Formation, among others such as the Frederick Brook Formation in New Brunswick) were deposited in periods ranging from the late Cambrian (≈ 490 mybp – millions of years before the present) to the late Ordovician (≈ 450 mybp). Each of the organic-rich units was formed during a relatively short time interval in a restricted-circulation shallow sea, likely several hundred metres in depth, when the organic matter production rate was very high. The major organic material deposited in these periods of intense biological production came from algae, a single-celled animal, and most of us have heard of “algal blooms” that take place nowadays when conditions are appropriate (appropriate nutrients, temperature...). Algae (and other animals that form sedimentary organic matter) create their cell walls by synthesizing large oily molecules called “lipids” so that a hydrophobic membrane exists between the aqueous interior of the cell and the outside aqueous world. In contrast, plants create their cell walls with lignin and polysaccharides (cellulose), which is why plant matter cannot generate large oil molecules, only lighter HC molecules (mainly natural gas) and coal, when buried and subjected to anaerobic decomposition by methanogenic archaeobacteria.

Normally, organic material produced by algae and other animals in oceans and lakes is recycled into the biosphere by scavenger organisms such as other fish, crustaceans and bacteria in conditions where there is some oxygen present in the water and in the pore water in the upper few meters of the sediments. In special cases, some of the organic matter generated in the sea survived bacterial consumption because of a lack of oxygen at the bottom of the shallow sea. These anoxic conditions were generated by excessive organic material generation in areas where the sea water was not rapidly circulating, so instead of being consumed, the organic matter was buried along with the fine-grained

⁸⁵ Lavoie, D. and Chi, G. 2010. Lower Paleozoic foreland basins in eastern Canada: tectono-thermal events recorded by faults, fluids and hydrothermal dolomites. *Bulletin of Canadian Petroleum Geology* **58(1)**, 17-35.

sedimentary particles (silts and clays). This surviving organic matter was buried and compacted, the excess water expelled from the dead cells, and the complex lipid molecules became agglomerated into kerogen – a semisolid organic material rich in complex lipids. The world's largest known deposit of organic rich rocks that contain kerogen which has never been buried deeply enough to generate oil and gas is the Colorado Oil Shales.⁸⁶ It is estimated that this deposit could yield hundreds of billions of barrels of oil if an economic and environmentally acceptable technology could be developed to “cook” the kerogen with heat and convert it to oil and gas.

As these organic-rich strata were buried deeper and deeper, higher temperatures, pressures and stresses acted on the kerogen, and at a burial depth of several kilometers, or at the depth where temperatures of about 60-70°C are exceeded, the kerogen started to break down into smaller liquid and gaseous hydrocarbon molecules, leaving carbon behind as a residue. This is part of the reason that source rocks such as the Green Point Formation tend to be almost always black shales: they are black because of the residual carbon (and some micropyrrite) that is the residue from the oil and gas generation; and, they are fine-grained rocks called shale, characteristic of sediments laid down in the quiet water conditions that existed when the organic material was accumulating.

As oil and gas were formed by the diagenetic conversion of kerogen (a process also called catagenesis), the additional fluids generated in the fine-grained (shale) source rock led to an increase in the pressure. The extremely fine-grained nature of the source rock inhibited easy flow out of the rocks because of low permeability and capillarity effects (capillary forces between water, oil and gas phases), so the pressure could not be released by normal porous medium flow through the pore throats. The pressure built up until the rock underwent fracturing when the pressure exceeded the smallest stress in the earth at the depth at which the fluids were being generated. This is a form of natural HF that must occur when pressures in the pore fluids are extremely high, and natural HF processes have been carefully studied by geoscientists for many years (e.g.: as a control on orientations of volcanic dikes and sills, Motokai and Sichel 2008⁸⁷). The elongated parallel features that emit lava episodically in Iceland and underneath the ocean along the Mid-Atlantic Ridge are “frozen” natural hydraulic fractures.

The mechanism of liquid formation and fracturing is shown in Figure 13. Kerogen particles in the first part of the diagram carry the vertical stress because they act as a solid material. As they are converted to fluids by the higher temperatures at greater burial depths, the pore pressure builds up until it exceeds the horizontal stress, at which point a vertical fracture is generated. Once these naturally induced fractures propagate with additional fluid input and reach a more permeable bed, the oil and gas can escape. All source rocks that have generated oil and gas fluids have evidence of these pathways generated naturally to allow the fluids to escape.

Most of the fluids generated by these oil and gas forming processes are expelled from the source rocks during the time they are formed. Because these fluids are buoyant (lower density than the formation pore water), they tend to migrate upward, and may become trapped in porous sandstone or carbonate reservoirs if suitable conditions exist. Probably the vast majority of oil and gas generated over geological time from deep source rocks eventually worked its way up to the surface where it vented to the ocean or the atmosphere or was biodegraded over time to create bituminous residues (the oil sands of AB and SK are migrated bacterially viscosified conventional oil from deep in the basin, 400-500 km to the southwest of where they are now found). On the west coast of Newfoundland, many oil seeps and residual organic matter in outcrop rocks are evidence of source rock oil generation, and there must also have been a great deal of gas that was emitted to the atmosphere. The oil in the seeps is geochemically identified as coming from the ancient source rocks at depth, mainly the Green Point shale (Hinchey et al. 2015).

⁸⁶ ostseis.anl.gov/guide/oilshale/ among many other reputable sites can be accessed for information about the Colorado Oil Shale.

⁸⁷ Motoki A., Sichel S.E. 2008. Hydraulic fracturing as a possible mechanism of dyke-sill transitions and horizontal discordant intrusions in trachytic tabular bodies of Arraial do Cabo, State of Rio de Janeiro, Brazil. *Geofísica Internacional* **47(1)**, 13-25

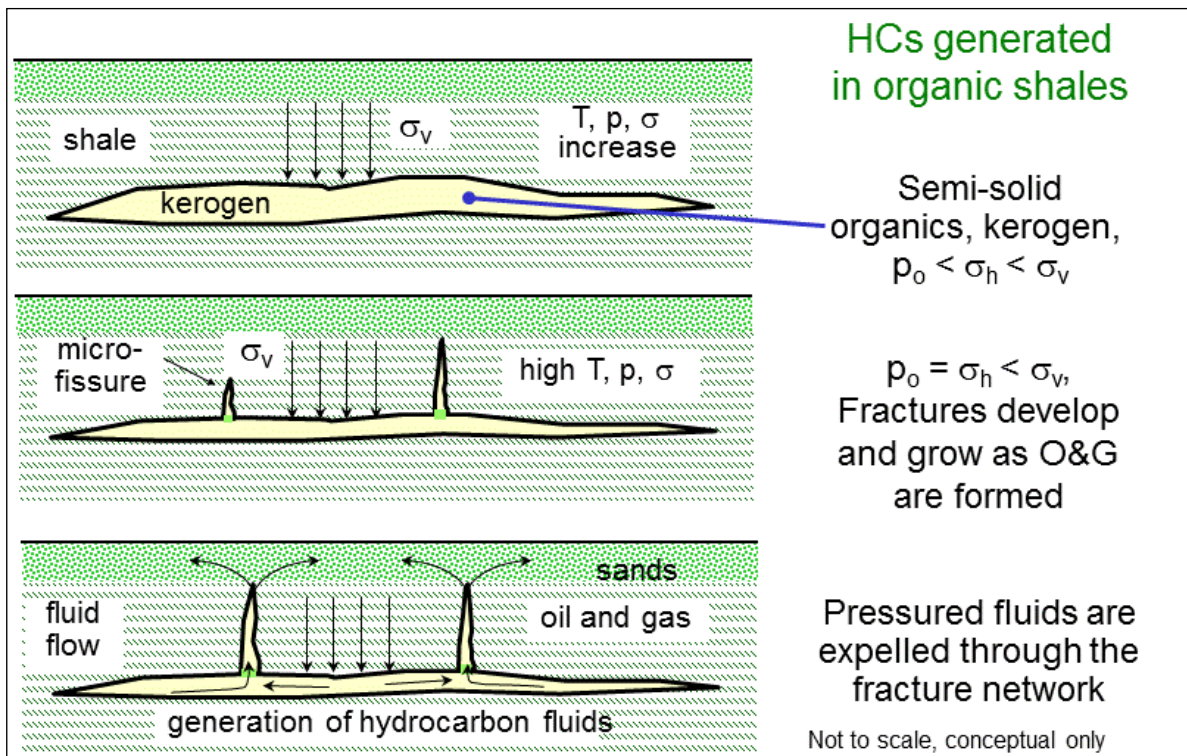

Figure 13. Expulsion of HC fluids from source rocks involves hydraulic fracturing.

However, some of the generated oil and gas may remain in the source rocks after most is expelled. In this case, the gas that is present is dissolved in the oil phase, as is the case in the Green Point shale. In other cases, the nature of the organic material laid down was more conducive to the generation of natural gas, rather than oil, and the source rock contains a great deal of carbon rich matter and natural gas adsorbed on the organic matter and in the pores and natural fractures. This is the case, for example in the Utica Formation in the St Lawrence Lowlands, and in the natural-gas rich coals of Nova Scotia.

These source rocks are now attracting the attention of the oil and gas industry because of the technological developments that have led to their commercially viable development – horizontal drilling and multi-stage HF along the axis of the well. Development activities are taking place in areas like North Dakota and southeastern Saskatchewan (the Bakken Formation play), southern Texas (the Eagle Ford Formation play), western Alberta (Duvernay, Cardium and other plays), northeastern British Columbia (Horn River shale gas play, Montney Formation shale gas and condensates play), Pennsylvania and Ohio (Marcellus Formation and Utica Formation plays), New Brunswick (Frederick Brook Formation play), and other regions. Now, Europe is starting to focus on such resources in order to provide domestic natural gas and displace coal and perhaps some oil as a source of power.⁸⁸

The Green Point Formation has a TOC – Total Organic Content – that has been measured in the range of several percent up to 10%,⁸⁹ and it has been buried in the geological past to the right depth for the formation of lighter hydrocarbon molecules. Thus, it was a source rock from which oil and gas were generated in the region (along with

⁸⁸ Buchan D. 2013. *Can Shale Gas Transform Europe's Energy Landscape?* Published by Centre for European Reform. www.cer.org.uk, 10 pages

⁸⁹ Enachescu, M.E and Foote, W. 2009. *Call for Bids NL09-03, Parcel 1*, Regional Setting and Petroleum Geology Evaluation, Government of Newfoundland and Labrador, Department of Natural Resources, www.nr.gov.nl.ca/mines&en/oil/

some other source rocks mentioned previously).⁹⁰ Probably the vast majority of the oil that was formed has escaped to the surface, but in the Green Point Formation there is still a sufficient oil content that some believe it can be commercialized using modern technology consisting of horizontal wells and HF because, although naturally fractured, the Green Point Formation is a fine-grained rock of low intrinsic permeability, and the natural fractures are mainly closed under the high stresses at depth. The natural fractures (joints) and bedding planes that form surfaces of weakness are relatively easily opened during HF stimulation so that a network of open paths of large surface area can be generated.

The depth to the top of the Green Point shale is \approx 1000-3500 m and it is variable in the Port au Port area because of a westward dip and some gentle folding. Because much of the Green Point Formation of interest is under the Port au Port Bay or under the sea surrounding the Peninsula, the concept of onshore-to-offshore drilling from land-based drilling pads, shown in Figure 3, has been generated.

For the rest of this report, a focus on technology and potential environmental impacts will be taken.

Development decisions by commercial interests will depend not only on technology and environmental factors, but a full assessment of the potential of the play will depend on many additional factors including depth, richness, thickness, gas/oil ratio, response to fracture stimulation, costs of developing infrastructure, and so on. The current knowledge about the geological conditions at depth is not adequate to develop a strong sense of the potential commercial value of any possible play, this could only happen through the drilling of a number of additional exploration wells (from 5 to 10 likely) because of the structural complexity of the region. Each of these wells would, ideally, be used to assess the potential formation production, and the knowledge from the first well will guide the testing strategy in the second well, and so on. This is a typical unfolding of a resources play in a complex area as the appropriate geological and resource models are improved with each bit of additional data collected.

It is impossible to say at the present time if the Green Point shale represents a genuine commercial petroleum play. These decisions always take time and require the necessary collection of information. Nor is it possible to say that the Green Point shale is non-commercial; those decisions change with the price of oil and the cost of development, both of which have experienced massive changes in the period 2014-2016.

⁹⁰ Dietrich J., Lavoie D., Hannigan P., Pinet N., Castonguay P., Giles P., Hamblin, A.P. 2011. Geological setting and resource potential of conventional petroleum plays in Paleozoic basins in eastern Canada. *Bulletin of Canadian Petroleum Geology* **59(1)**, 54-84.

SHALE OIL AND GAS DEVELOPMENT APPROACHES

There is a general commonality in the development practices for shale oil and shale gas strata, and indeed for tight sandstones. The general approach is to use multiple-well development sites (pads) to drill long horizontal well sections in the target reservoir. In this article, a number of figures indicating shale gas wells will be used, but the technical commonality of the drilling and completion approach means that these images, and much of the discussion that follows, applies equally to shale oil or to shale gas development. First, the well design will be discussed; then the pad design and global configuration will be presented. Later, in the Energy Well Integrity section, more technical details will be added to the discussion.

Design of a MSHF Well

Multiple individual locations of openings (perforated intervals, sliding sleeves, pre-installed liner ports) are installed along the length of the horizontal section of the well through which HF is implemented to increase the flow capacity of the zone around the horizontal section of the well. A vertical section of part of a single horizontal well configuration is shown here in Figure 14.

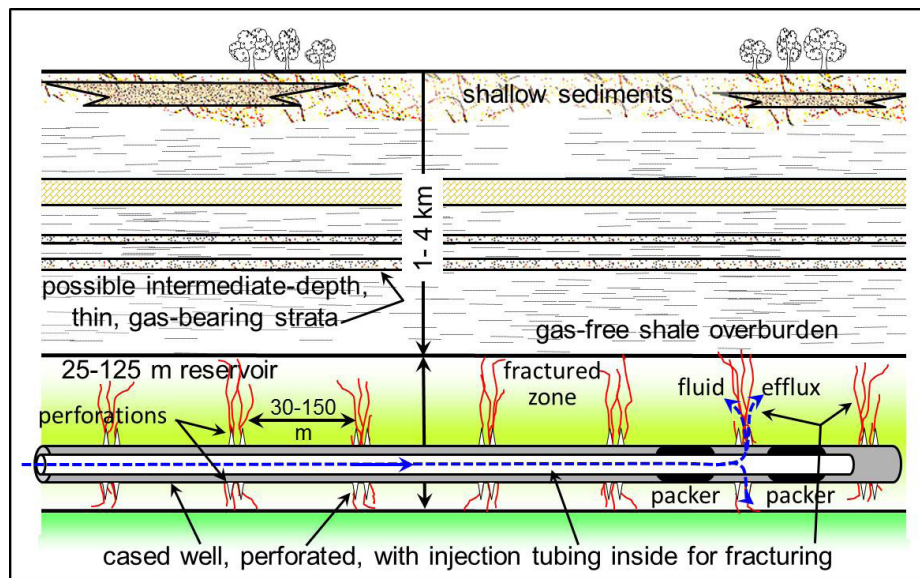

Figure 14. A vertical section of a Multi-Stage Hydraulically Fractured (MSHF) horizontal well.

There are multiple entries to the formation for stimulation by HF, and there are several technologies available to make these openings so that HF is done in a controlled manner. This general approach is called MSHF – Multi-Stage Hydraulic Fracture, and is a new development in the oil and gas industry dating from the period 2000-2005. The key commercial aspect of this approach is to maximize the extent to which each single well can access the formation containing the resource, making a large drainage volume available for each well. Thus, it is not necessary to drill a large number of vertical wells to access the reservoirs, which are generally thinner than 200 – 300 m (exceptions exist, such as the Frederick Brook Formation in NB which can be over 800 m thick in places⁹¹). Figure 14 shows part of a long horizontal well section that could be from 1.5 to 3 km in length. The "plug-and-perf" method is shown: an interval in the closed steel casing is isolated by two packers so that the zone may be perforated and therefore allow HF fluids and

⁹¹ Park, A. 2014. Shale Gas in New Brunswick: Geological Background. Chapter 2 in *Shale Gas in New Brunswick: Towards a Better Understanding*. Canadian Institute for Research on Public Policy and Public Administration, Sallient R. (editor and contributor). ISBN 978-0-88659-304-9

proppant to go into only the one cluster of perforations zone. In other configurations, several perforated intervals may be isolated together by packers and simultaneously subjected to HF; however, because this reduces somewhat the ability to control the outcomes in each of the HF stages, this approach is becoming less popular. New technologies are being developed to make this MSHF process more efficient (more rapid) so that the costs for a typical MSHF well have dropped by over 30% in the period 2010-2015 and continue to drop.⁹²

Stimulation through HF, in the configuration shown in Figure 14, takes place sequentially, with one perforated interval after another being isolated and fractured, generally moving from the toe of the horizontal section (the most distant point) to the heel of the section. All MSHF stimulations of wells seek to maximize the volume of the reservoir that can be drained, within reasonable cost. The optimum spacing between stages and the optimum treatment strategy (volumes, rates, materials, proppant density, viscosity of fluids...) are chosen based on previous experience, accounting for the response of the formation and its geometrical disposition. For example, in the Horn River play in northeastern British Columbia⁹³, a large reservoir thickness means that large volumes of fracture fluid are used in each stage, perhaps as much as 3500 m³ per stage and 100,000 m³ for a single 3 km long horizontal well section. These volumes of aqueous HF fluid injected in a single well stimulation program are probably close to the largest in the world at this time because of the great thickness of the productive part of the Horn River Formation. In the Marcellus Formation in Pennsylvania, however, injection volumes per stage are much smaller, a few hundred m³, because the formation is thin (40-50 m), and because there appears to be no strong barrier to upward HF propagation at the top of the shale gas interval (it is desirable to keep fractures from propagating excessively above the top of the productive horizon).

The depth numbers in Figure 14 are reasonable, but represent a range only; for each play there will be a range of depths. In the case of the Green Point Formation in the Port au Port Bay area, the depth to the horizontal wellbore could potentially be as shallow as 1000 m to the east toward St George's Bay (if the formation is found to be at such depths), or as much as 3500 m west of Long Point or at the southern tip of the Port au Port peninsula.⁹⁴ This is not shallow fracturing, so the interaction of deeply injected fracture fluids with the surface is not feasible. If fracturing takes place at some future time, these depths mean that limits of fracturing volumes and rates will not have to be severely prescribed.

It was mentioned that having induced HF propagate a significant extent above the target zone is a negative outcome, except in so much as it is necessary to carry proppant high enough to achieve the desired results. During early stages of asset exploration, once there is some idea about the commercial prospectivity of the Green Point Formation, companies will collect information about the strata and carry out monitoring during HF trials of progressively increasing complexity and size to assess fracture behaviour so as to allow guidance of further development.

The optimum placement of the wellbore within the formation depends on factors such as the horizontal and vertical stresses and their orientations, the nature of the HF fluids to be used (density, viscosity), and the injection pressure and rate used in stimulation. In some cases (e.g. the Barnett Shale in Texas), it is necessary to avoid excessive downward HF propagation to avoid intersecting a water-bearing stratum below the base of the target zone, but also to accommodate a desire on the part of the companies to have the fractured interval connect two zones separated by a low-value intermediate zone. The Marcellus Shale in the northeast USA shows stronger upward HF propagation, so in that case a major design factor is achieving a sufficient height to carry proppant up to near the top of the production

⁹² The sharp drop in gas prices in 2010-2011 and in oil prices in 2014-2016 has forced the industry to reduce costs, so that the horizontal well and MSHF technology are becoming less costly in response to market forces, not just technical developments.

⁹³ Rogers S., Elmo D., Dunphy R., Bearinger D. 2010. Understanding Hydraulic Fracture Geometry and Interactions in the Horn River Basin Through DFN and Numerical Modeling. *Proc. Canadian Unconventional Resources and International Petroleum Conference*, Calgary, Alberta, 12 p (SPE #137488-MS – available through OnePetro™)

⁹⁴ Black Spruce Exploration Co. 2014. Unlocking the Oil and Gas Potential of Western Newfoundland. Promotional slide show downloaded from BSL website in 2015. www.blspexp.com

horizon. Each play is different and the fracturing techniques will evolve with time as more is learned.

The stimulation size (volume) at each perforated stage along the axis of the well, and the spacing between stages, are also factors to be optimized during the planning and early development stages when trial fracturing in horizontal wells is carried out. These values are subject to change as more is learned, and as HF approaches evolve. In particular, it is not known how well-contained the HF will be within the Green Point Formation, so the lateral spacing of the wells is not known yet, nor the volume of a HF treatment. The plan view shown in Figure 15 is a possible (highly idealized) MSHF approach with horizontal wells spaced 100 m apart laterally.

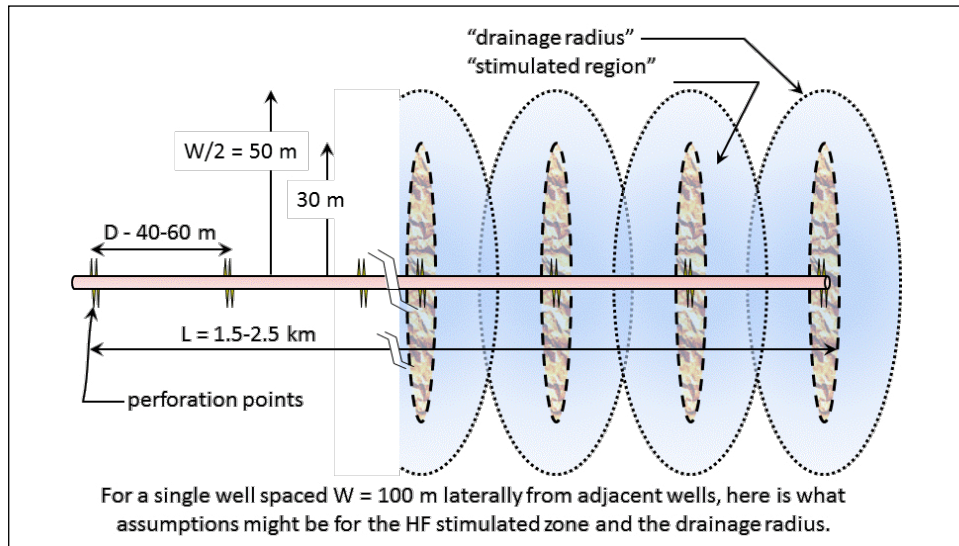

Figure 15. Plan view: the concepts of a stimulated region and a drained volume.

In this figure, the concepts of a stimulated region directly affected by the MSHF operation, and a drained region that is much larger, are shown. Though the Green Point Formation matrix permeability is low, HF stimulation will generate small perturbations beyond the region of fracture network and fracture propping, and over the life of the well, the volume within the drainage radius will contribute to production. Another unknown factor is the degree to which the natural joints and bedding planes within the Green Point Formation are flow channels (slightly open), and how they might respond to the HF stimulation. For example, if it is determined that a significant number of the natural fractures are flow paths that will remain open, it is even conceivable that a long horizontal well could achieve commercial rates of production without MSHF stimulation.

In the idealized scenario sketched above, it is assumed that the stimulated zone limit is about 50 m on either side of the wellbore, a realistic scenario for a productive zone that is on the order of 30-80 m in thickness. Although the Green Point shale is generally much thicker, little is actually known as to the productivity potential over the entire vertical extent of the strata. If the productive zone is 60-100 m thick, HF stimulation volumes would be larger, but the wells would also be spaced farther apart, perhaps 200 m apart, depending on how the formation responds to the HF stimulation (unknown as yet). In the figure, the fractured zones themselves do not overlap, but the drainage regions overlap somewhat. Quantification of these aspects for optimization can only be achieved by monitored production trials and geomechanical modeling.

In some cases, such as in the Frederick Brook Formation in New Brunswick, formation thickness is many hundreds of metres and development can be undertaken with vertical wells (Figure 16) with fracture stages being spaced along the axis of the vertical well portion that crosses the productive horizon. Generally, in such cases, the stimulation fluid volumes are much less than those for long horizontal wells.

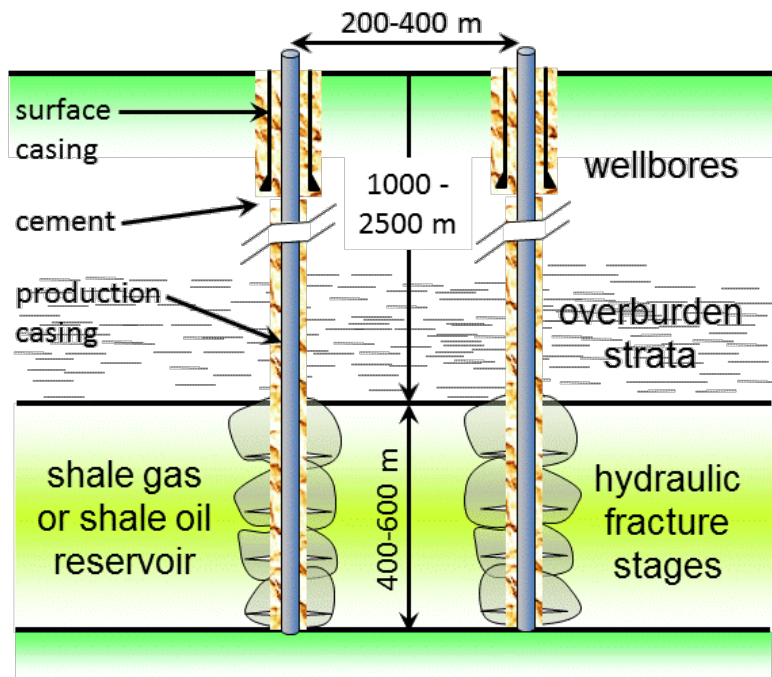

Figure 16. Vertical well MSHF completion for thick shale gas or shale oil deposits.

In deposits that are less than 125-200 m thick, the formation height is too small for use of vertical wells with MSHF technology. At depth, adjacent wells might be configured as shown in Figure 17. In this representation, only six fracture stages along the axis of the horizontal well section are shown for artistic purposes, and only the fracture stimulated zone is represented by the ellipsoids; the more extended drainage volume explained in Figure 15 is not shown in Figure 17. Again, it must be remembered that these figures are highly idealized and simplified to emphasize the concept. The details of the shapes of the fracture stimulated zone in practice are impossible to delineate with precision.

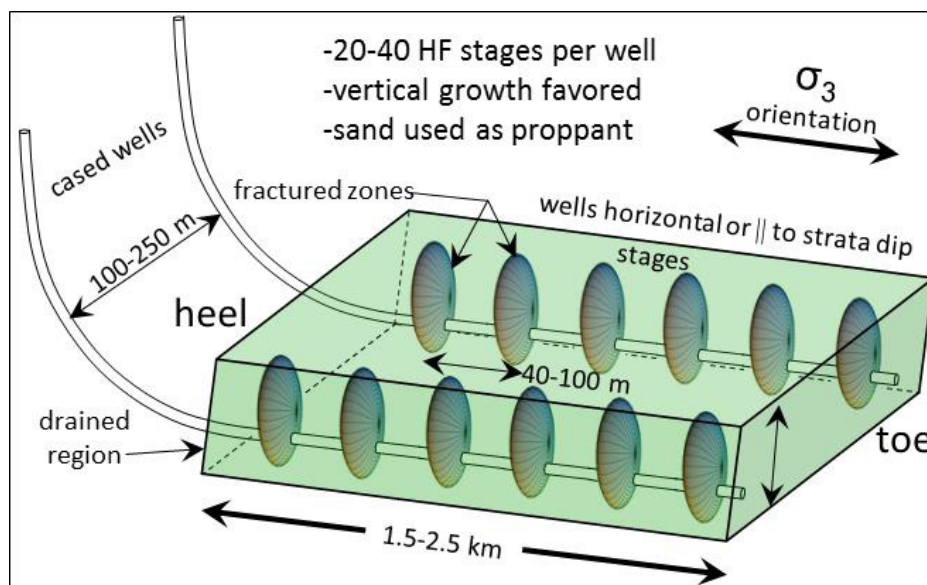

Figure 17. Configuration of MSHF wells at depth.

The two wells shown in Figure 17 will be flanked by other parallel wells, and will be drilled from the same pad (Figures 1, 2, 3). Many other wells can also be drilled from the same pad because of advances made in the directional drilling of wells in the 1990's, the use of downhole drilling motors (mud motors), data transmission to the surface while drilling to allow bit steering, and so on. Although the drilling and fracturing industry appears superficially to be roughly the same in 2015 as it was in 2005, major changes have taken place that have resulted in increases in horizontal well length, more fracture stages along the well, larger treatment volumes, cheaper drilling costs, and improved HF stimulation results.

Pad Placement

Development of a shale oil resource using many wells from single pads has become commonplace, used throughout the development plays referred to as the Eagle Ford (South Texas) and the Bakken (North Dakota and Saskatchewan)⁹⁵. Because the length of the wells has become longer and longer in practice (although perhaps 2-2.5 km is about optimum for the Green Point Formation), the area drained by a group of wells on a single pad can be substantial. As shown in Figure 17 and 18, it is preferred to place the horizontal wells parallel to the direction of the minimum principal horizontal stress – σ_3 – to get the best results because hydraulic fracture stimulated zones extend perpendicular to the direction of σ_3 . Hence, all the wells are placed parallel to each other.

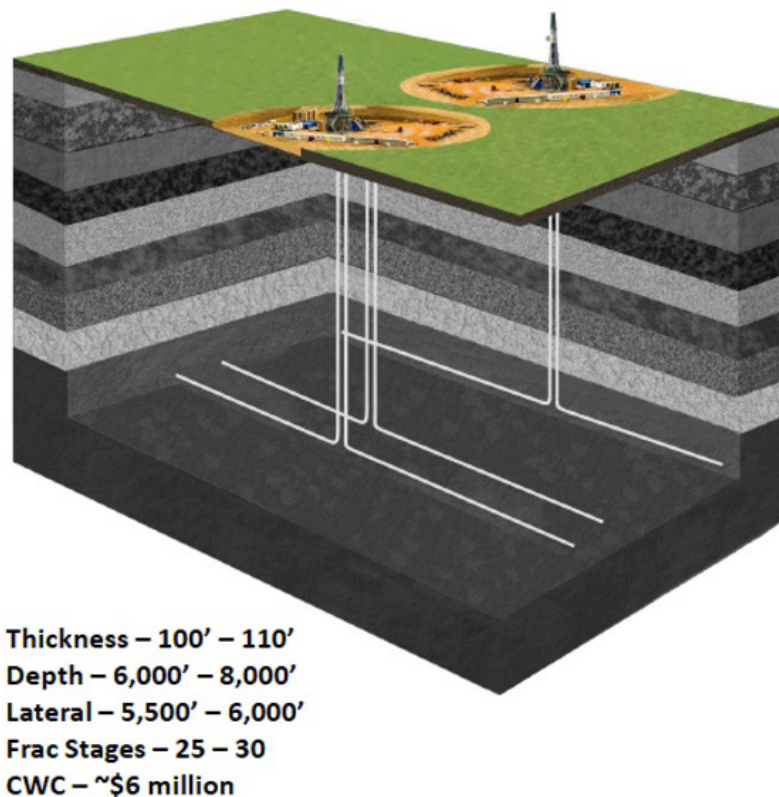

Figure 18. MSHF Wells in a Pad Configuration, Courtesy Forest Oil corporation for the Eagle Ford Play.

Progress continues to be made in the sophisticated directional drilling needed to place wells in the optimum locations and spacings, and the ultimate surface area of a development pad in Western Newfoundland will not be the same

⁹⁵ Jarvie D.M. 2012 . Shale resource systems for oil and gas: Part 2—Shale-oil resource systems, in J. A. Breyer, ed. *Shale reservoirs—Giant resources for the 21st century*. American Association of Petroleum Geologists Memoir 97, 89-119.

everywhere because of different depths and geological factors. The surface area of a typical pad may be 1-2 hectares during development (Figure 19), reduced in area once well development is finished.



Figure 19. HF well stimulation in northwestern Alberta (courtesy of Trican Well Services).

This approach of many wells from a pad reduces surface impacts, simplifies infrastructure development, and minimizes environmental risks. During drilling and HF, the development pad is heavily occupied, as shown in Figures 1 and 19, but even more important for environmental impact reduction of development is that the area drained in the subsurface may be on the order of 6-12 km² in a typical development scheme. And, as technology progresses, this may expand; for example, in Figure 3 an extended reach drilling scheme was conceptually combined with parallel wells about 200 m apart to give the impression of what draining a region approaching 20 km² might entail. If the Green Point shale proves commercially interesting, Figure 1 shows just how small the surface pad area can be to drain a vast subsurface area, and Figure 20 shows a project stimulating a series of previously drilled wells with a total pad area of less than a hectare (not counting the water storage pond off the picture).

Generally, in areas of soft soil, the development pad is covered with a graded gravel section for stability, and perhaps a liner or a strong geotechnical fabric is placed under the gravel as well to provide drainage control and stability. More and more, drilling companies are using large moveable carpets made of wooden units each 10 m long and 3.5-5 m wide to give excellent traffickability on site. The site itself in Canada is surrounded by a shallow berm and a ditch for drainage. Fracturing fluids and fracture flowback fluids are stored in tanks, not lined lagoons, in this picture. This use of tanks is mandated in Canada for fracture flowback fluids that are considered even marginally hazardous, but for HF fluids that have no toxicity, such as "slickwater" flowback fluids, temporary storage may be allowed in lined surface lagoons.

A development pad will experience three major activity phases in its lifetime of 20-40 years before it is decommissioned:

Site Preparation and Drilling: The site is accessed, cleared, and steps taken to ensure environmental compliance, soil stability, and groundwater protection. Monitor wells for groundwater may be installed, and the regulator may require baseline data to be collected. Drilling commences, with one or two drilling rigs, and, depending on the well depth and array, from eight to twenty development wells might be drilled and completed (cemented and prepared for HF stimulation). This process may take a full half year.



Figure 20. HF well stimulation in the United States (courtesy Trican Well Services).

Hydraulic Fracture Stimulation: Once all drilling equipment and related surface facilities are withdrawn and the site re-prepared, the HF equipment and materials are assembled on site, and each well, one after the other, is stimulated by MSHF. Preparation may take a month or more, and the entire stimulation operation may take as much an additional 100-125 days for a large number of wells (12-20).

Production: Once all HF equipment is removed, the site is partially rehabilitated and prepared for long-term production by installing well pumps and tubing using a service rig; by installing flowlines, tanks and other equipment needed to support the production phase; and, by making provision for future re-stimulation of wells or other well entry activity such as re-installation of pumps. Figure 21 shows an array of “donkeys” on a production pad in North Dakota. Many operators use electrical submersible pumps, and the surface view for electrical pump wellheads is surprisingly unimpressive.



Figure 21. A multi-well pad during production in the Bakken Shale: likely, electrical pumps would be used in Western Newfoundland

The pad is designed so that re-stimulation of wells and other well maintenance functions can take place over the course of the well life. The ultimate well life for a shale oil well is not yet well understood because significant scale development only began in 2009-2010, and one may rest assured that as time goes on, new, less costly, and less complex stimulation methods will be implemented to extend the profitable life of the well as much as possible. A pad life of between 20 years and 40 years seems reasonable, taking into account previous oil industry experience.

Rehabilitation: After the last production well is deemed uneconomic and well decommissioning is complete, the development site is returned as much as is economically feasible to its original condition, or to a condition agreed upon when the development license was issued. Desirable infrastructure (roads, bridges, power lines...) may be left in place and handed to local authorities, or removed if considered invasive. Site rehabilitation and revegetation tend to be pushed back in time because new technologies for enhanced oil recovery tend always to be developed, and these technologies are then applied to the wells to recover more oil. For example, in the future, enhanced recovery may be economic using supercritical carbon dioxide (miscible CO₂ injection⁹⁶) or special solvents, and this would extend the economic life of the site. Realistically, and sometimes regretfully, delaying well decommissioning for cost reasons can also delay rehabilitation.

HYDRAULIC FRACTURE MECHANISMS

HF has been criticized as an environmentally dangerous technology. Practice in Canada shows that this is not correct and the environmental impacts are reasonably well understood. Although all industrial activities have risks, hydraulic fracturing does not stand out in any way as a major risk element to public health nor to environmental protection.

For example, the references in footnotes 44 and 45, which are reports of Canadian expert panels that tabled their conclusions with respect to the Canadian context in 2014, analyze and largely dismiss subsurface risks associated with the HF practice itself.⁹⁷ However, they do not dismiss the need for regulations, quality control, surface risks mitigation, and well integrity concerns. In other words, risks arising only from the well stimulation practice of hydraulic fracturing are extremely small, and regulatory attention should be focused mainly on two issues: surface activities (traffic, spill potential, storage of chemicals) and long-term well integrity, mainly the issue of slow natural gas migration along the exterior of cased wellbores.

These studies did not undertake independent research, but depended exclusively on the scientific and engineering literature to arrive at their conclusions. Other studies around the world have reached similar conclusions, and in January of 2016, one of the more definitive assessments of hydraulic fracturing risks was published by the BGR in Germany.⁹⁸ The conclusions, after deep and exhaustive studies are direct and clear. The most pertinent one to the discussion here can be summarized as:

*"From a geoscientific perspective, protection of drinking water and hydraulic fracturing are compatible [in the context of possible shale gas development in Germany]."*⁹⁹

⁹⁶ Yu W., Lashgari H.R., Sepehrnoori K. 2014. Simulation Study of CO₂ Huff-n-Puff Process in Bakken Tight Oil Reservoirs. *Proceedings Society of Petroleum Engineers Western North American and Rocky Mountain Joint Meeting*, Denver, Colorado, 16 p. (SPE #169575-MS available through OnePetro™)

⁹⁷ To be clear, in this discussion, a strict differentiation is made between hydraulic fracturing as a well stimulation practice (*sensu strictu*) and the tendency for those not familiar with oil industry technology to use the term hydraulic fracturing as a globally inclusive term for all the activities associated with the processes of exploration, drilling and producing resources from unconventional sources such as shales and tight sandstones.

⁹⁸ BGR Deutschland [German Federal Institute for Geosciences and Natural Resources]. 2016. *Schieferöl und Schiefergas in Deutschland – Potenziale und Umweltaspekte*. Downloadable (in German) from: www.bgr.bund.de/DE/Themen/Energie/Downloads/Abschlussbericht_13MB_Schieferoelgaspotenzial_Deutschland_2016.html To be translated into English in months to come.

⁹⁹ Translated by the writer from the German press release issued by the BGR on January 18 2016.

Thus, the fact-based opinion of the scientific world is that, with appropriate care and regulatory practices, HF itself is not an issue. Explaining why this is so can be challenging, and this section is dedicated to explaining and understanding the physical mechanisms associated with hydraulic fracturing.

As mentioned previously, HF can take place as a natural process or as a process induced by human activity. Learning from nature can give valuable insights into fracturing processes. However, each reservoir reacts differently, and the examples from nature are sufficiently different from man-made fracturing to make it necessary to develop mathematical modeling methods and measurements to aid in the design and assessment process. Because the process is complex and there are always uncertainties, and although modeling approaches are widely used, trial fracturing and early development fracturing is necessary to achieve good HF designs in practice and to understand the process for the particular reservoir case.

Fracturing in Nature

In nature, examples of hydraulic fracturing processes include the emplacement of dikes and sills during volcanic activity¹⁰⁰, the creation of sediment bodies called injectites¹⁰¹, quartz vein development in igneous rocks¹⁰², gas release from subsea reservoirs¹⁰³, and so on. Several of these are described because understanding the natural occurrences of HF helps to understand the behaviour of man-made HFs.



Figure 22. The world's mid-oceanic ridges are natural hydraulic fracturing sites.

The ash clouds arising from the eruption of the Icelandic volcano Eyjafjallajökull in 2010 caused major air traffic disruption over Europe and the North Atlantic for weeks. Iceland is on the Mid-Atlantic Ridge, part of a global pattern of ridges that are the growth centers for the World's oceanic crusts (Figure 22).

Deep convection currents in the Earth's mantle (Figure 23), moving at rates of a few millimetres per year, are slowly pulling apart the crust in the regions of the mid-oceanic ridges. Generally, the lateral stress is the smallest, or the

¹⁰⁰ Delaney P.T., Pollard D.D., Ziony, J.I., McKee E.H. 1986. Field relations between dikes and joints: Emplacement processes and paleostress analysis. *Journal of Geophysical Research* **91(B5)**, 4920–4938.

¹⁰¹ Braccini E., de Boer W., Hurst A., Huuse M., Vigorito M., Templeton G. 2008. Sand Injectites. *Oilfield Review*, Summer Issue, 34–49, www.slb.com/resources/oilfield_review.aspx

¹⁰² Sibson R.H., Scott J. 1998. Stress/fault controls on the containment and release of overpressured fluids: Examples from gold-quartz vein systems in Juneau, Alaska; Victoria, Australia and Otago, New Zealand. *Ore Geology Reviews* **13,1-5**, 293–306

¹⁰³ Clennell M.B., Judd A., Hovland M. 2003. Movement and Accumulation of Methane in Marine Sediments: Relation to Gas Hydrate Systems. Chapter 9 in *Natural Gas Hydrate*, V. 5 in Springer Link (Publishers) series: Coastal Systems and Continental Margins, Editor Max M.D., 105–122. doi:10.1007/978-94-011-4387-5_9

minimum principal compressive stress in these cases ($\sigma_{hmin} = \sigma_3$), and the slow movements in the upper mantle tend to slowly pull apart the rocks, although no open cracks are created. The process might be more correctly called “extensional straining” or “extensional deformation”. The magnitude of σ_{hmin} is reduced by this process until it becomes less than the pressure (p_f) in the molten lava in the magma chambers under the ridges; then, a hydraulic fracture takes place relatively suddenly, as in the Eyjafjallajökull eruption. The process involves millions and millions of cubic meters of fluid lava moving upward, relieving the pressure in the magma chamber to the point where the lava can no longer be pushed upward. At this point, the eruption ceases, the lava filling the new hydraulic fracture freezes, and the process of crustal extension continues episodically, driving continental drift and mid-oceanic ridge growth.

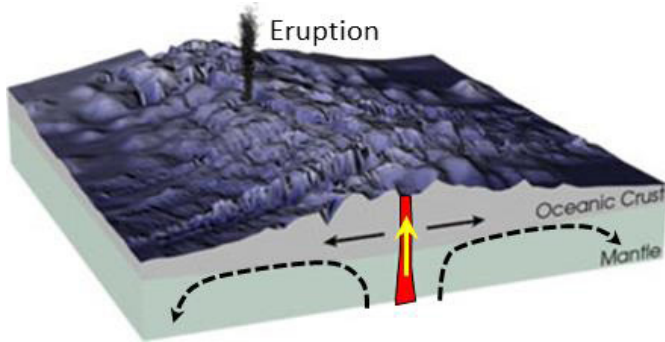

Figure 23. Deep mantle convection reduces horizontal stress, and hydraulic fracturing ensues.

HF processes generate the dikes and sills that are seen in ancient rocks, or around active volcanoes or eruptive sites nowadays. Earth scientists understand that these features propagated as planar features normal to (at 90° to) the smallest stress in the ground (σ_3 or σ_{hmin} if it is horizontal). In Figure 23, the horizontal arrows show the direction of crustal “pull-apart” or extension, and this corresponds to the direction of σ_3 – the least compressive horizontal stress in this case. The fracturing pressure in the fluid lava – p_f – had to overcome the value of σ_3 in order to rise, and this is known as the HF condition: a HF in the earth, whether natural or man-induced, can only form when the pore fluid pressure (the lava in the case above) exceeds the minimum stress: $p_f \geq \sigma_3$. If the orientation of σ_3 is horizontal, the HF will be vertical, as in the dikes shown below. If σ_3 is vertical, a condition that is common near the surface of the earth in the first 1000 m or so, a sill will form. If old dikes are noted at the surface because of uplift and erosion, as in Figure 24, one may be sure that at the time of the emplacement of the liquid lava as a HF, the compressive stress at 90° to the plane of the dike was also the smallest principal stress at that time.



Figure 24. Dikes radiating from shiprock NM are natural hydraulic fractures.

Nature tells us a great deal about the role of stresses and induced stress changes in hydraulic fracture emplacement. The two major dikes visible in Figure 24 are at 90° to each other, and one dike (the closer one) is far larger than the other. This is in keeping with the existence of a natural stress field in the earth, as well as the changes that can be induced in that stress field by the fracturing process. In this case, the earlier fracturing episode led to one set of dikes, but the forcing open of the HF plane affected the local stresses until the secondary set was emplaced. The same happens in man-made HF, and some of these effects are discussed below.

Induced HF Behaviour and the Earth's Stress Field

A hydraulic fracture is an opening in the earth generated by injecting a fluid at a bottom-hole pressure somewhat greater than the minimum principal stress – $p_f > \sigma_3$. Because the earth is a rigid material, it must deform smoothly, and mathematical mechanics¹⁰⁴, confirmed by laboratory¹⁰⁵ and field measurements¹⁰⁶, show that the opening created by a fracture must have an approximately elliptical cross-section for all the major axes, it must be very thin in the direction of σ_3 compared to the other directions, and the deformation shape must be relatively smooth.

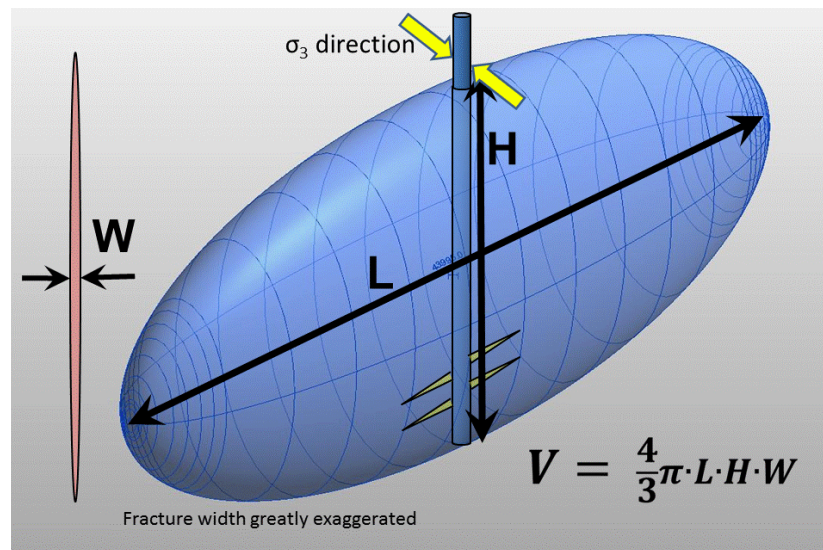

Figure 25. A hydraulic fracture in the Earth is approximately ellipsoidal in shape.

In Figure 25, a vertical wellbore is sketched, with perforations at the bottom of the well to access the rock formations. The wellbore could just as well have been horizontal; it is the orientation of the Earth's stress field, not the wellbore orientation, which controls the hydraulic fracture attitude. In this case, which is the most common case at depth (though not necessarily for the Green Point Formation and almost certainly not for shallow fractures), it has been assumed that the minimum stress is horizontal, therefore the orientation of the hydraulic fracture is vertical, and at 90° to the direction of σ_3 . In terms of relative scale, one may assume that the length and height of hydraulic fractures in a MSHF well are on the order of tens of meters to perhaps 250 m (tip to tip), whereas the thickness is on the order of millimeters to several centimeters, depending on the fracture size, the rock properties, and the Earth's stress field. So, the ellipsoid in the diagram, and even the small cross-section to the left, greatly exaggerate the typical width of a HF plane.

¹⁰⁴ Wang G., Dusseault M.B., Rothenburg L., Pindera J. 1994. Influence of Subsurface Fractures on Surface Deformation of an Elastic Half-space. *International Journal of Analytical and Numerical Methods in Geomechanics*, **18**, 287-303.

¹⁰⁵ Wang G., Dusseault M.B., Pindera J. 1995. Experiments on Surface Deformation from a Sub-Surface Fracture. *Canadian Geotechnical Journal* **32(6)**, 1024-1034.

¹⁰⁶ Dusseault M.B. Simmons J.V. 1982. Injection-induced stress and fracture orientation changes. *Canadian Geotechnical Journal* **19(4)**, 483-493.

The fracture length and height are not the same, but in a uniform stress field and uniform rock they will be roughly equal so that a vertical view would be approximately circular in shape. Cases where a vertical HF propagates laterally considerably more than vertically will be discussed, but in general the height cannot be much larger than the horizontal length for a vertical hydraulic fracture. From the point of view of mechanics, during propagation the fracture length and height tend to stay similar to each other because of viscous energy dissipation within the thin fractures. Although a fracture can grow vertically more than it grows horizontally (perhaps by a factor of two), it is not realistic to postulate a fracture with a height several times greater than the horizontal length in a layered sedimentary rock mass such as found in the Port au Port area. Long thin fractures are not energetically feasible.

In HF stimulation using horizontal wells, the preferred orientation of the well is in the same direction as σ_{hmin} (which is generally also σ_3). The reason is shown in Figure 26. If the well is aligned parallel to the largest of the horizontal stresses, σ_{HMAX} , the fracture planes will parallel and intersect the wells, and will not depart laterally. In the orthogonal direction, the fractures are transverse, and a larger volume of reservoir rock can be accessed by the induced fractures, hence it is the preferred well orientation used during development of shale oil and shale gas development, in order to optimize the stimulation process.

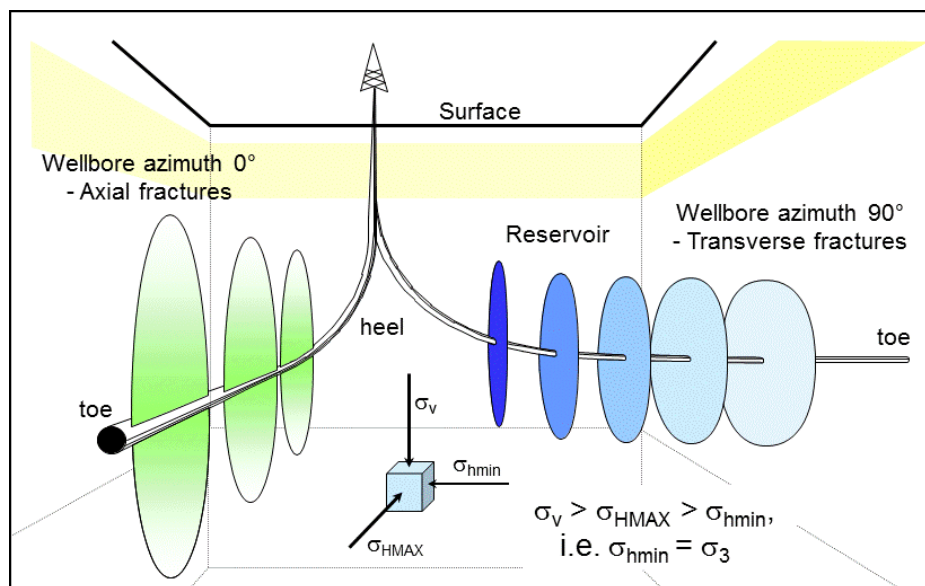

Figure 26. Preferred well orientation is parallel to σ_{hmin} .

This knowledge means that a development pattern will likely be quite different from the general concept shown in Figure 3. More likely, the wells will be drilled in more parallel directions over the entire Port au Port Bay area once knowledge of the stress directions is acquired.

Figure 24 shows several dikes emanating from a volcanic stock, the longest and widest dike was placed first, and as the dike grew longer, it also had to grow wider (a principle of mechanics), and this increased the stress acting normal to the plane of the dike. At some point, the stress acting normal to the dike became locally greater than the other vertical stress, so the continued lava injection led to a secondary dike at 90° to the first one, initiating at the injection point, which is the eroded volcanic stock remnant in the lower left hand corner of Figure 24. This concept is expressed in Figure 27; here, a hydraulic fracture was initiated and it propagated some distance at 90° to the initial direction of σ_3 . However, as the fracture propagated, it also had to become thicker in the middle (i.e. the fracture aperture had to increase). This increasing aperture caused enough of a stress increase that at some point the fracture re-initiated near the wellbore, and a secondary fracture propagated out, at about 90° to the original fracture, as shown in the case of the volcanic dikes, and observed in practice.

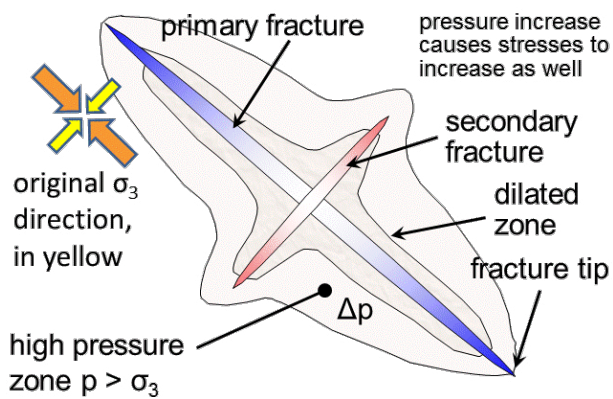

Figure 27. Induced fracturing can change local stresses.

This figure therefore represents an important principle of fracture propagation. It is not mechanically possible for an induced fracture to propagate indefinitely in one orientation; after some volume of injection, the local stress fields are altered, and the fracture will change direction. Footnote 107 refers to an article that studied this effect in the field and in mathematical modelling. Changes in fracture orientation during pumping were observed decades ago, and the physical reasons are well understood. Hence, because of several factors, the length of induced fractures tends to be limited.

Hydraulic Fracture Rise

The issue of hydraulic fractures rising has attracted attention in the non-refereed media as a potentially important environmental issue. For example, in Québec, concern has been specifically expressed¹⁰⁷ that hydraulic fractures could rise in an uncontrolled manner so that the HF fluids might interact with the GW. The mechanics of HF placement is further investigated in this section, specifically focusing on the potential for fracture rise and the risks of intersecting shallow potable GW in the Western Newfoundland region.

Figure 28 shows a serious **misrepresentation** of the behaviour of hydraulic fractures.¹⁰⁸ This diagram seems to imply that fractures are generated close to the groundwater zone, and therefore that potable water resources are at great risk because of potential contamination from the subsurface. As mentioned previously in this report, all science panels and research groups with the proper expertise have debunked such claims.

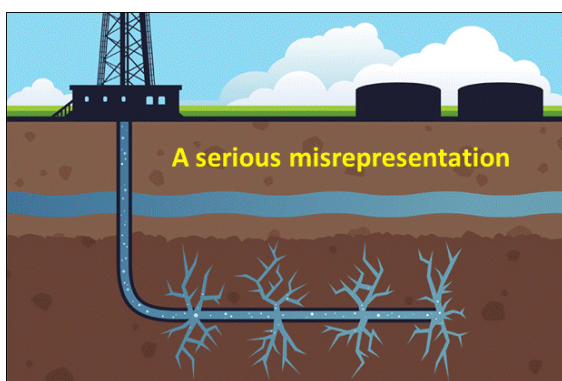

Figure 28. Hydraulic fractures do not behave in this manner.

¹⁰⁷ Professor Marc Durand in Québec (UQAM) has published non-refereed internet-based documents that infer that hydraulic fracturing has a high risk of resulting in HF fluids rising 100's of metres to interact with the groundwater zone. It is important to emphasize that this non-refereed claim has no basis in fact, is purely speculative, and is based on incorrect assumptions and inappropriate interpretation of the data of others.

¹⁰⁸ blog.worldwidemetric.com/trade-talk/the-pros-and-cons-of-fracking-for-oil/

Regulatory Issues

Although investigations have been done and information published, the specific details of the depth to the base of potable water in the Port au Port area – BGWP – are not fully clarified, and this will constitute a “work-in-progress” if and as development takes place. Because of the topography and the steepness of the water table gradient in most areas, plus the proximity to the sea, it is likely that aquifers are relatively shallow, and isolated one from the other. For example, the residents of Lourdes use local groundwater, but the aquifers exploited do not flow into the Lourdes area from the north east or southwest; the groundwater almost certainly flows from the south east, down the slope of the land. Furthermore, the west coast of Newfoundland is a region of appreciable rain. This means that the fresh groundwater is being continuously renewed, and the older groundwater is flushed toward the sea quite rapidly, compared to the case in a dry climate with very flat topography. Nevertheless, risks must always be properly managed, and this may affect regulatory controls in various ways.

It may, for example, be required of each operator of a multi-well pad that a GW surveillance well be installed before drilling and that the water at different levels be sampled to determine BGWP. The GW well would then also be used to establish baseline GW geochemistry, and serve as a surveillance well to allow periodic (e.g. each two years) assessment of the GW quality. It is suggested that a standard be adopted, such as 3000 or 4000 ppm total dissolved solids¹⁰⁹, to define empirically the boundary between GW that is potentially useable for human use (not only direct consumption, but for other uses), and GW that is too saline to be of direct use.

It might be mandated that drilling sites be close to the sea coast and not “upstream” of villages so that if any surface spill occurs, the flow tendency would be towards the sea and any contaminated GW would not intersect private or village wells. Locating development pads to meet the needs of local communities is feasible because directional drilling and extended reach wells can be used to access the resource at some distance from the well pad. Assessing such possible guidelines and potential regulations is part of any possible development path, not only in Western Newfoundland, but anywhere in Canada that resource development or industrial activity takes place.

It is important to remember throughout the technology assessment activities linked to possible Western Newfoundland shale oil development that ultimately the regulatory agency established by the NL government has the right to establish and modify guidelines to mitigate risk, if these risks are considered to be large enough to warrant changes in the development approach. These guidelines (rules) are based on a vast body of experience in other jurisdictions, modified for local conditions. For example, regulatory guidelines designed to reduce risks associated with HF typically include:

- Requirements placed on the corporations to carry out quantitative risk management if HF is to take place within some specified distance to BGWP (e.g. within 200 or 300 m of BGWP). This issue could not arise in the case of the Green Point shale.
- Limits on depths at which HF is allowed (e.g. no HF within 50 or 100 m of BGWP, or shallower than 500 m). Again, such a constraint is likely irrelevant to HF in the Green Point shale.
- Limits on total HF volumes or volumes of individual stages for wells closer to BGWP (e.g. smaller injection volumes per stage for shallower wells).
- Restrictions or prohibitions on the use of certain chemicals (e.g. prohibition of the use of fluids containing certain concentrations of heavy metals in solution).

¹⁰⁹ Different jurisdictions use somewhat different values for this limit. Alberta uses 4000 ppm tds, for example. The limit could also be expressed in terms of electrical conductivity, as this is easily measured immediately in the field, and the relationship between conductivity and total dissolved solids – salts – is well-understood. See Rhoades J.D. 1996. Salinity: Electrical Conductivity and Total Dissolved Solids. Chapter 14 in *Methods of Soil Analysis, Part 3: Chemical Methods* – Soil Science Society of America Book Series, No. 5. p 417 ff

- Requirements that fracturing be supervised directly by a professional engineer or accredited technical expert who is not an employee of the fracturing company or the oil company.
- ...and so on...

Guidelines for risk mitigation of hydraulic fracture operations promulgated by the regulatory agency should be based on science and engineering experience, substantiated by monitoring, and applied systematically. However, as mentioned previously, there is merit to consider outcomes-based regulations rather than prescribed values. Increased understanding of fracture behaviour, development of non-hazardous fracturing fluid formulations, use of other fluids or gases (CO_2 , N_2 , CH_4 , C_3H_8 ...), better monitoring approaches, and other developments will gradually change how HF's are designed and implemented, and too rigid a regulatory framework leads to suppression of innovation. Because these guidelines are evolving rapidly at the present time in various jurisdictions in North America and Europe, it is appropriate to establish a separate study to assess the usefulness of various guidelines and rules in the context of Western Newfoundland (modest population, little agriculture, vast quantities of water available, etc.), and to assess the value of outcomes-based regulations.

Injection vs. Hydraulic Fracture

Active HF conditions means that the pressure in the induced fracture (during injection) is slightly higher than the value of σ_3 in the ground ($p_f > \sigma_3$) at the depth at which the fracturing is taking place. Typically, at a depth of 2.5 km¹¹⁰ in the Port au Port area, given the fact that the major tectonic features are associated with compression along the WNW-ESE directions (roughly 90° to the coastline) one would expect a σ_3 ($= \sigma_{\text{hmin}}$) value at these depths to be similar to or perhaps slightly less than the value of the vertical stress $-\sigma_v$.¹¹¹ The average density of the overlying rocks at this depth are about 2.5 g/cm³, so $\sigma_v \approx 62\text{-}63$ MPa, and σ_{hmin} is likely similar, although it would not be surprising to see a condition where the vertical stress is smaller than the horizontal stresses.

Fluids in the Green Point Formation are at a pressure that is roughly equal to the column of seawater, perhaps up to 10% higher (a vertical gradient of 1.03 to 1.2 g/cm³, Hinchey et al. 2015). This means that the pore fluids are approximately "normally pressured"¹¹² and not under an unusually high pressure at depth. At 2.5 km depth, the existing pressures are almost certainly in the range of 27-32 MPa.

During hydraulic fracturing, a process which, for each stage in a MSHF well, will take no more than several hours, the fracturing pressure is much larger than the in situ pore pressure: $p_f \approx 63$ MPa; $p_o \approx 30$ MPa. There would be a large pressure gradient outward from the open fracture as long as pumping continues. However, this high pressure gradient also causes fluid "leak-off" during fracturing, so that the volume (and therefore the extent) of the open hydraulic fracture is invariably less than the volume of fluid injected.¹¹³ It is possible to give reasonable predictions of the "largest possible extent" by assuming that the leak-off is zero, but this condition never exists in practice, and the leak-off behaviour during hydraulic fracturing can only be determined through trial measurements. In extreme cases of substantial rock deformation by tectonic movements, some of the naturally existing fractures are significantly open; this may be the case in some areas of the Green Point Formation although the high stresses at depth predicate

¹¹⁰ Probably the majority of the prospective region is less deep than 2.5 km; then, the estimates of stresses and pore pressures are adjusted accordingly.

¹¹¹ The assumptions in this section are reasonable, given the lack of specific data, but the numbers will be modified slightly if and when data become available. There is substantial uncertainty about the value and orientation of the horizontal minimum stress at this time.

¹¹² These technical terms are defined in glossaries that can be easily accessed. One of the better ones is found at www.glossary.oilfield.slb.com/. Other glossaries in print accompany government and review panel publications from various agencies and countries. It is recommended to also access the following text: Zoback, M.D. 2007. *Reservoir Geomechanics*. Cambridge University Press, Cambridge UK, 449 pp.

¹¹³ The most recent and definitive text on hydraulic fracturing is considered to be: Smith, M.B., Montgomery, C. 2015. *Hydraulic Fracturing*. CRC Press (Taylor and Francis Group), 812 pp. ISBN 9781466566859

against this. In such a case, the leak-off may be so severe that it becomes impossible (or impractical) to propagate a hydraulic fracture outward a significant distance from the injection point.

Once active HF ceases, high fracturing pressures start to dissipate, but they also continue to diffuse out into the medium. The fluids that are moving through the rock mass beyond the hydraulic fracture do not have a tendency to move up or down; as long as there is a zone of higher pressure remaining for a while after pumping ceases and the densities of the fluids are roughly the same, the fluids move preferentially along paths of higher permeability. These more permeable paths can be permeable zones, usually parallel to bedding (e.g. in a fine-grained sandstone), or fluids can flow along joints and other natural fractures (e.g. in a permeable naturally fissured carbonate).

Fluids may also be injected under pressures higher than the fluid pressures elsewhere in the rock mass¹¹⁴, but without fracturing, as might be the case for example of an acid treatment to clean the near-wellbore environment. These fluids will also flow outward from the injection point. In the case of the Green Point shale and its overlying strata, the intrinsic permeability of the rock matrix is probably too low to permit appreciable matrix flow; it is likely that the only pathway for significant flow is through discontinuities such as joints or fractured zones. Also, flow through joints can take place only if these joints are sufficiently conductive; i.e., if the aperture of the natural joints are sufficiently large to allow significant flow, and if the joints are interconnected so that there is a continuous pathway for fluids to take. In all cases, the higher pressure in the local area of the hydraulic fracture at depth will dissipate with time as a function of the large-scale formation permeability.

If a formation that is to be stimulated by HF is found to have a high fluid leak-off coefficient that severely inhibits fracturing, as determined by well testing during the exploratory phase well before fracturing, additives can be used in the fracturing fluids to partially counteract this fluid loss. For example, the HF fluid viscosity can be increased by adding polymers, or finely ground materials such as CaCO₃ are added to block conductive joints and reduce the rate of fluid loss so that the efficacy of the HF treatment is improved. The leak-off of the fluids during HF into low permeability rocks takes place in all directions, but generally the greatest flux will be in the direction along the joints of largest conductivity, unless a more permeable stratum is encountered.

The proportion of the HF fluid that leaks off during HF stimulation is typically in the range of 5-50%. A fracture stage may involve 1000-2000 m³, but in the context of the storage capacity of the porous rock mass (≈10%) and the natural fracture system, the HF fluids can invade only a comparatively small region surrounding the wellbore being stimulated. Hence, these fluids will flow limited distances from the actual hydraulic fracture, perhaps 100-150 m. Note that pressure responses can be recorded at great distances from a HF injection point because aqueous HF fluids are of low compressibility and a pressure increase is easily transmitted with little movement of the pore fluid. However, bulk flow is quite local to the region around the well that is being stimulated.

Many other factors exist that give effective constraints to the long-distance propagation of HF fluids, justifying the conclusions of the BGR mentioned previously. These factors can be demonstrated by straightforward calculations, and verified in practice or in the laboratory through measurements and experiments. A few of these factors are listed here, before the discussion is continued:

- Fractures will be at most in the range of 100-200 m in maximum dimension, compared to depths of perhaps 1000-3000 m in the Green Point strata, so the size of barriers between the zone at depth and the surface is large. Also, shallower HF involves lower volumes.

¹¹⁴It is a widely-held and perhaps appropriate professional opinion that in SW Newfoundland the use of deep-well waste liquid disposal techniques for large volumes of aqueous waste water will not take place. This is because of generally low permeability and low porosity strata, making the disposal of significant volumes (e.g. 500,000 m³ of waste water into a single disposal well) or rates (e.g. 1000 m³/day) problematic. However, this opinion remains conjectural, and smaller-scale disposal wells (lower rates and volumes) may be technically feasible and if these wells are sufficiently deep, environmentally secure. Such wells are used throughout the oil industry in Canada.

- As fluids flow through the porous and naturally fractured rock mass, they are diluted through dispersion, so that if there is any flow away from the HF location over time (not likely), any remnant chemicals in the fluid become attenuated dramatically.
- Clay minerals in the surrounding rocks will adsorb most chemicals found in fracturing fluids, so that over time the natural processes in the Earth lead to partial immobilization and cleaning of the injected water. (This is a standard purification process of filtering used to clean modest volumes of industrial waste water.)
- Minerals in the surrounding rocks will neutralize any excessive acidity or alkalinity of the fluids that might be used in HF.
- Production involves a drop in pressure, and 30-50% of the fracture fluids are removed as flowback during the first few days of well flow.
- Because of pressure depletion in the reservoir, outward flow from the producing formation ceases, and all flow is directed down-gradient, toward the producing well.
- HF fluids are not significantly buoyant and do not have a potential to rise upward strongly, as may be the case for oil (density as low as 0.75 g/cm³) or natural gas.
- There are small distortions that are generated in the rock mass during hydraulic fracturing and these create better flow pathways. However, these distortions are minor (several millimeters opening is probably the limit), and opening of natural fractures is limited to a region around the induced fracture zone. (In other words, long pathways are not opened by HF.)

Conclusions such as these are stated in general terms, quantification of the specifics must depend on the acquisition of data from the target formations.

Why Fractures Rise

Various stress conditions may exist at depth in the Green Point shale, an issue to be resolved only when accurate stress estimates are performed. The stress condition in the ground governs the attitude and orientation of the hydraulic fracture stimulated zone. A HF that is induced in a stress regime where the minimum principal stress is vertical ($\sigma_v = \sigma_3$) will propagate approximately horizontally, with little tendency to rise. The near-horizontal HF will propagate outward from the injection point and often tends to propagate along a single horizontal bedding plane that is a plane of relative weakness. So, the tendency for an induced fracture to rise out of the zone being stimulated is essentially zero if the vertical stress is less than the horizontal stresses. This condition may exist at depth in the Green Point shale because of the general large tectonic compression that took place in the millions of years of geological history after the strata were laid down.

However, a HF that is propagating vertically in a stress condition where the smallest stress is horizontal will have an additional tendency to rise. The reason for this is shown in Figure 29 where an image of a propagating hydraulic fracture plane is sketched in vertical plan view and in vertical cross-section. In the case of aqueous-based HF fluids, the density is usually in the range of 1.0 to 1.2 g/cm³, depending on the amount of proppant and the salinity of the water. For example, fresh water with a small amount of polymer to reduce frictional pressure losses ("slickwater") has a density of 1.0 g/cm³. Even high viscosity HF fluids constituted with polymers such as guar gum or xanthates will have a density only slightly larger than 1.0 g/cm³, if the water is not saline. If a HF fluid has 15% quartz sand proppant by volume in fresh water, the total fluid density is still only 1.25 g/cm³. Within the open HF plane during pumping, the pressure at the top of the fracture is less than the pressure at the bottom of the fracture because of the density of the water, and the change in pressure is about 10-12 kPa per vertical meter. This is called the "pressure gradient". However, the horizontal stress in the rock mass almost invariably has a gradient that is much higher, in the range of

17 kPa/m to as high as 23-24 kPa/m. The difference between the stress gradient in the rock mass and the pressure gradient in the HF leads to an excess of pressure at the top of the fracture, helping it rise, and to a deficiency of pressure at the bottom of the fracture, inhibiting downward propagation. This has been referred to as buoyancy, but in the strict sense, it is more rigorously interpreted in the manner described above.

HF carried out with gases or gelled propane will tend to lead to greater fracture rise because the densities of these fluids are lower than water, and their viscosities are also low. However, in all cases, whether aqueous or non-aqueous fluids are used, once the active fluid injection with a water-base fluid ceases and the fracture closes, this effect of induced fracture rise disappears, and there is also no further tendency for the HF fluids to rise, although there will continue to be some outward flow until the excess pressure dissipates.

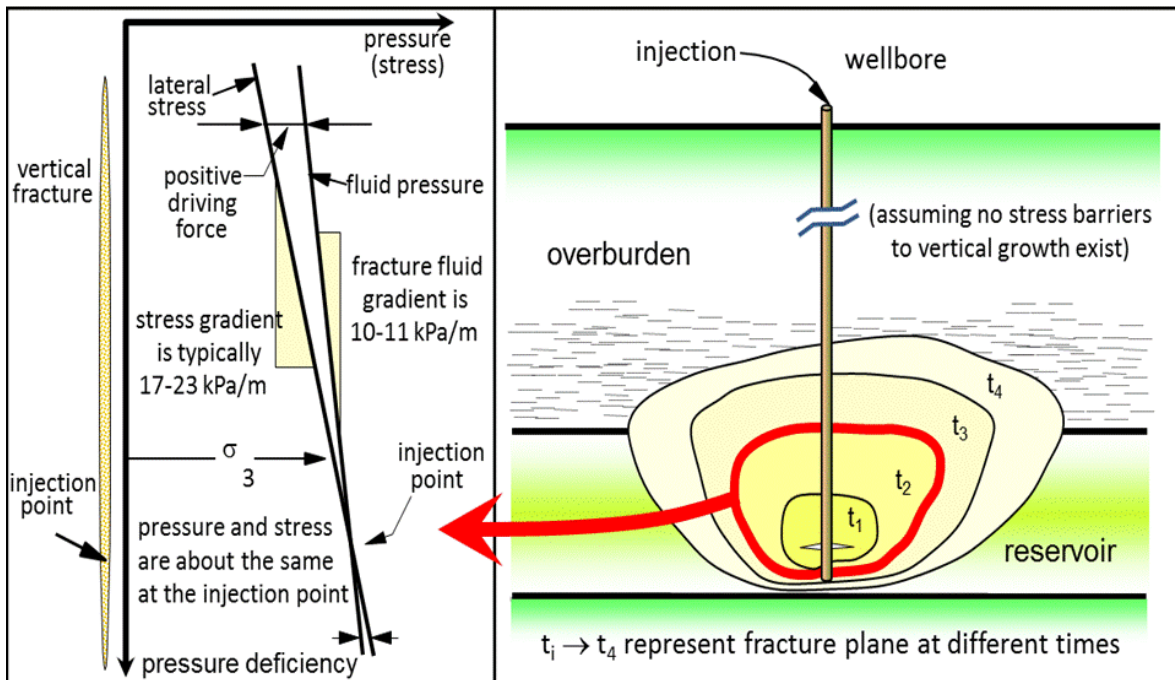

Figure 29. Why hydraulic fractures tend to rise.

Because fractures can rise only while there is active HF going on, the next issue is how much can they rise.¹¹⁵ The next sections will show that the amount of fracture rise is severely limited by a number of factors. In fact, microseismic information collected over the last 10 years shows that fracture rise is quite limited.¹¹⁶ Figures 30 and 31 are taken from the paper by Fisher and Warpinski (2012) and modified slightly; work by these authors in the period 2000-2015 (much earlier in the case of Warpinski) is considered seminal in the understanding of how hydraulically induced fractures propagate.

Figures 30 and 31 demonstrate that the tendency for HF rise above the target formation is generally limited to several hundred feet (100-200 m). The maximum height above the fracture stage at which a microseismic event is registered and recorded in this figure. The black circles are drawn to highlight several cases where MS events were recorded at extreme heights above the injection point. Most cases shown here and in other similar data plots show few or no

¹¹⁵ Daneshy, A.A. 2009. Factors Controlling the Vertical Growth of Hydraulic Fractures. Proceedings, Society of Petroleum Engineers Hydraulic Fracturing Technology Conference, The Woodlands, Texas, SPE #118789.

¹¹⁶ Fisher K., Warpinski N. 2012, Hydraulic fracture height growth: Real data: *SPE Journal of Production & Operations* **27(1)**, 8-19 (SPE #145949-PA). This article, based on hundreds of cases of data collection in practice, discusses fracture vertical growth, showing that induced fractures terminate far below the groundwater level, generally close to the top of the target formation several kilometers down.

microseismic events more than ≈200 m above the injection point. However, the highest microseismic event recorded during a fracture stage is neither the true height of the HF, nor is it even the height of the HF stimulation fluid migration during injection. When fluids are injected aggressively during HF, pressures are altered far from the opened fracture itself, and far from the actual physical presence of fracture fluids. The fluids used are water-based, and water is almost incompressible. Because the formation pore and joint fluids are also largely incompressible (there is probably no free gas in the Green Point Formation), they can also transmit pressures easily over great distances, and during HF the pore pressures in conductive natural joints will increase substantially far in advance of the presence of any actual HF fluid.

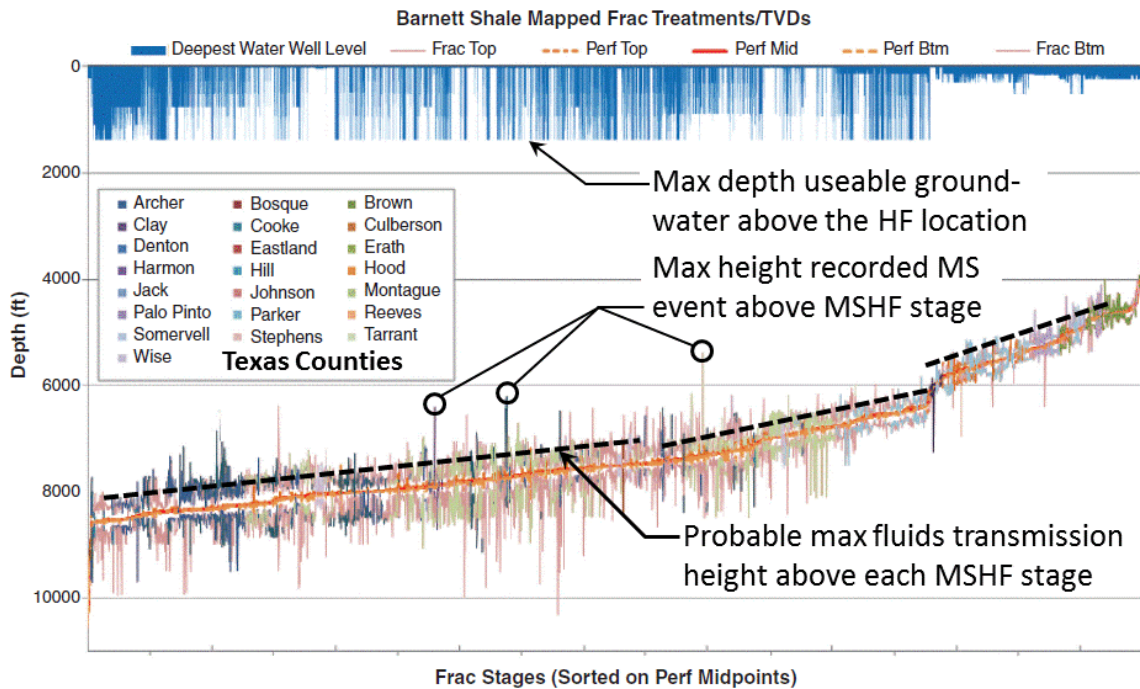

Figure 30. Microseismic emissions for MSHF stages, Barnett Shale (Fisher and Warpinsky 2012).

The opening of a hydraulic fracture under aggressive pressurization also distorts (strains) the rock mass for a limited region around the open HF, and this can change the stresses on joints that are somewhat more distant from the injection point than the open fracture itself. This combination of high pressure transmission and stress change far in advance of (above) a propagating fracture can generate a small stick-slip event on a bedding plane or a favorably oriented joint in the NFR mass. This stick-slip event is what generates a microseismic (or acoustic) emission, which can be recorded on nearby geophones or accelerometers, and is now widely used as an aid to HF design in practice.¹¹⁷

On the plot in Figure 30, several dashed lines were added by the author and labeled as the probable maximum bulk fluids transmission height above the injection point. Although the specific location of this line is somewhat conjectural (there are differences in volumes and rates among different MSHF stages, as well as differences in fracture fluid formulation and rock properties), it was drawn at a reasonable location, approximately 400-500 feet (150 m) above the fracture initiation depth. Assuming that induced fractures rise far above the initiation point is not factually supported nor is such a conclusion advocated by any author who has extensively studied field data. The microseismic events that are recorded in the field can take place far above the point where HF fluids have penetrated. They are not “maps” of the extent of hydraulically induced fractures.

¹¹⁷ Warpinski N.R., Wolhart S.L., Wright C.A. 2001. Analysis and Prediction of Microseismicity Induced by Hydraulic Fracturing. *Proceedings of the Society of Petroleum Engineers Annual Technical Conference and Exhibition*, New Orleans, Louisiana, 13 p, (SPE #71649-MS, available through OnePetro™).

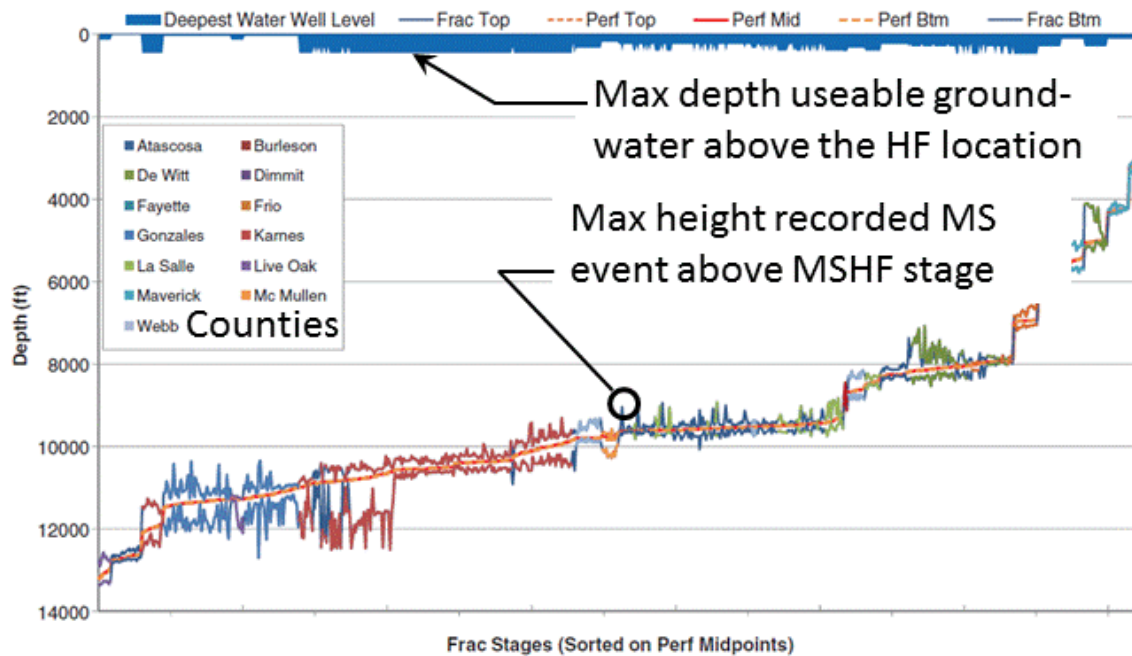

Figure 31. Microseismic events in Eagle Ford hydraulic fracturing (Fisher and Warpinsky 2012).

Figure 31 is likely more representative of what might occur in the Green Point Formation if stage volumes of 200–500 m³ are used. The Eagle Ford is a shale oil play, whereas Figure 30 was developed for the Barnett Shale, a shale gas play (also in Texas). The size of hydraulic fracture treatments tends to be smaller in shale oil plays, not least because the zones to be stimulated are generally thinner than in shale gas plays. The conclusions from the data are clear: the actual rise of fractures is limited to several hundred feet, and because shallower HF operations use smaller volumes, the risks of fracture fluid intersection with shallow groundwater are remote.

The Fracture Volume Effect

Any fluid leak-off occurring during active HF means less fluid volume within the HF opening, restricting growth and reducing fracture height for a given volume of fluid injected. Because HF fluid leak-off always happens, especially with low-viscosity slickwater fracturing (fracturing with water that contains a small amount of a polymer, usually some form of acrylamide polymer), the predicted HF shape and extent must be modified to account for the lower volume of HF fluids available to grow the fracture.

The volume of a crack in the Earth as a first approximation is that of an extremely flat ellipsoid, Figure 25. Suppose that a fracture with these dimensions is created by injection: $H = 100$ m, $L = 100$ m, $W = 0.03$ m. The volume is about 1250 m³ if there is no leak-off, an extreme assumption (see equation in Figure 25). This volume is much larger than typical single stage volumes used in shale oil development in places such as the Eagle Ford or the Bakken plays, but similar to or somewhat smaller than the volumes used in shale gas plays such as the Marcellus and the Horn River plays. Corporations have no incentive for vertical fracture propagation much above the top of the target; this is a waste of fluids, energy and time. However, some height above the target formation is needed to help transport proppant far enough in the productive formation to maintain the fractures open, especially with the use of slickwater fluids.

The fracture thickness (W – width or aperture) is a mainly a function of fluid viscosity during injection, the difference between fluid pressure and earth stresses ($p_f - \sigma_3$), the rock mechanical properties, and leak-off (Smith and Montgomery 2015). However, as a fracture grows in length, the width and height have to grow proportionately if other factors remain the same. This means that, other factors being equal, about eight times the volume is required

to double the height of a fracture. In other words, if H, L and W are each doubled, the volume increases by a factor of $2 \times 2 \times 2$, or eight times the volume of a fracture with half the height.

Returning to the example above, to double H in a single fracture stage, roughly eight times the volume with no increase in leak-off rate is needed, so a 200 m high fracture for a single stage would need $8 \times 1250 \approx 10,000 \text{ m}^3$. This is far larger than the largest stages used in extremely thick reservoirs (Montney or Horn River Formation). The largest stage volumes used are $\approx 3000 \text{ m}^3$, so vertical growth is constrained by the volumes available to inflate the fracture.

There are additional effects that limit vertical fracture growth, such as an increase of leak-off rate with time. As the area contacted by a HF increases during pumping, the fluid is contacting more and more surface area, including more conductive joints and other conduits for fluids. Thus, the leak-off rate gradually increases with fracture size, so as constant-rate pumping continues, less and less fluid is available to provide more volume for propagating the fracture. Even in thick shale oil zones, it becomes uneconomical to simply increase the volume of fracture treatment to achieve more formation contact, and in these cases more wells with smaller MSHF treatments will probably yield better results.

If low viscosity water-based HF fluids are used ("slickwater"), proppant carrying is not as efficient as with high viscosity fluids, so the proppants tend to settle in a typical vertical fracture configuration. Fluid leak-off rates are also higher because of the low viscosity, and the pumping rate (volume rate) is increased to improve the proppant distribution area and the stimulation effectiveness. So, the extent of fracture rise above the target zone is likely to be greater in such cases, compared to the use of a viscous fluid, and the overall volumes pumped are larger as well, to compensate in part for the increased leak-off rates. However, low-viscosity slickwater fracturing uses fluids that are non-hazardous (e.g. water with a non-toxic polymer in concentrations less than 0.2%), so the consequences of communication with aquifers are moderate to very low. As fracture fluids flow through porous media after fracturing ceases, the clay minerals and other silicate mineral adsorb molecules such as polymers, attenuating their concentration in a short distance. All these factors together, including those in the list outlined earlier, mean that the actual risks of HF to GW are very small.

Because of pressure losses in the fracture, viscous HF fluids and high pumping rates lead to shorter, fatter fractures, so fracturing with high viscosity fluids leads to less fracture rise. High viscosity fracture fluids are also much more expensive than slickwater, so smaller volumes are used.

Thus, in extreme cases a HF might have a vertical height of 150-200 m. This means that the top of the HF might rise above the top of the target formation by 50-150 m, although the probability of this happening is small in practice, given all the energy and mechanical constraints on fracture shape and growth, and the desire not to waste fracture fluids or pumping time. In cases of extremely thick reservoir intervals, companies tend to limit their initial developments to exploit the richest interval in the target formation to achieve good extraction ratios and production rates. This is happening, for example, in the Montney Formation in Alberta and British Columbia; within the 200-350 m thick prospective interval, development is focused on the best zone, near the formation top. In the future, companies will return to develop the less productive zones (and technology will continue to progress).

One may be sure that the Green Point shale is heterogeneous. As more information is extracted from cores and geophysical logs, the richer intervals will be delineated, and it is unlikely that attempts to fracture the entire vertical prospective extent of the Green Point shale would be carried out.

In the case of productive shale oil formations with great vertical extent, companies tend to use two or more levels of wells to have more control over the treatments and to achieve more economical limited height fracturing (Figure 32), as it becomes impractical at some point to try and gain more fracture height because of the additional volumes of fluid needed. A greater density of wells will also lead to higher recovery factors, and the wells can be repeatedly re-stimulated as the need arises.

Current Development: Bakken & Three Forks

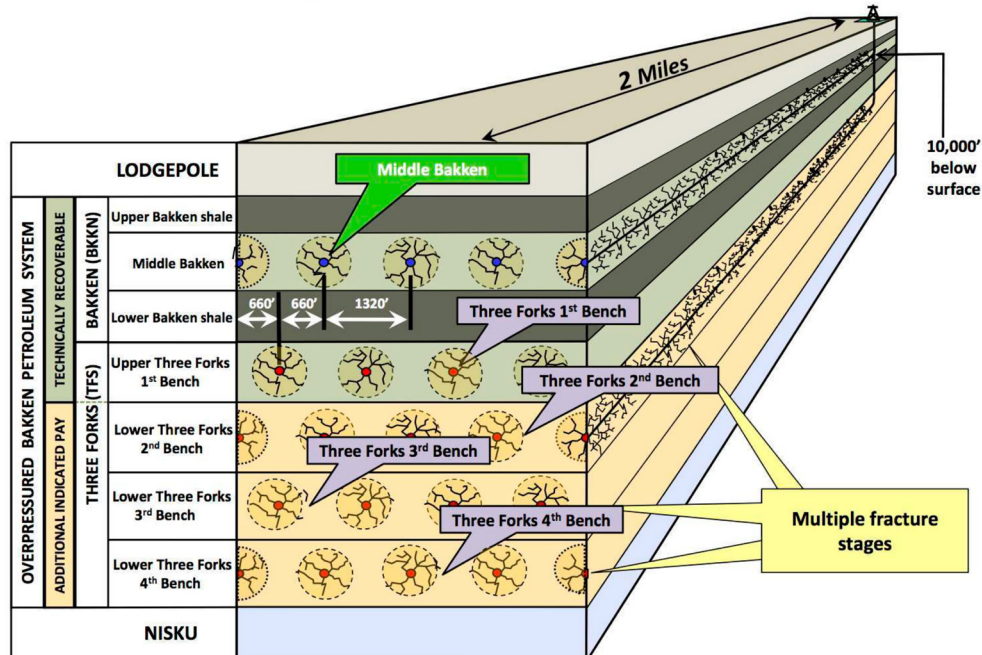

Figure 32. Small hydraulic fractures used in wells at different levels to control outcomes.

Stress Barriers to Fracture Rise

Although vertical stresses tend to increase uniformly with depth because of the increasing overburden weight as one goes deeper, horizontal stresses are more variable. It is often found that the horizontal stresses in the rocks above the target zone are slightly higher than in the target formation. If this is the case, an induced fracture tends to propagate much farther horizontally because it is more difficult from the point of view of work to push upward through the barrier. The concept is shown in Figure 33, and the limited vertical extent of induced microseismic events in the Barnett shale data shown in Figure 30 is considered to be evidence of a stress barrier that inhibits vertical fracture growth.

In the figure, the vertical stress $-\sigma_v$ is seen to rise steadily with depth, but the horizontal stress does not rise consistently and is a few percent larger in the caprock than in the reservoir. This situation arises because of differences in mechanical properties, tectonic history, stress and pressure changes over time, and diagenesis. For example, if the non-prospective cap rock above the prospective interval in the Green Point shale is denser, the porosity will be lower and it will be stiffer, Under the lateral compressive loading that occurred during the last significant tectonic episode, this stiffer stratum would have led to a higher horizontal stress, and hence a barrier. The condition as shown leads to excellent containment of the HF within the reservoir and this is conducive to more successful HF stimulation because more of the rock laterally can be drained by the fracture and little of the energy of fracturing is wasted on vertical fracture growth above the target stratum.

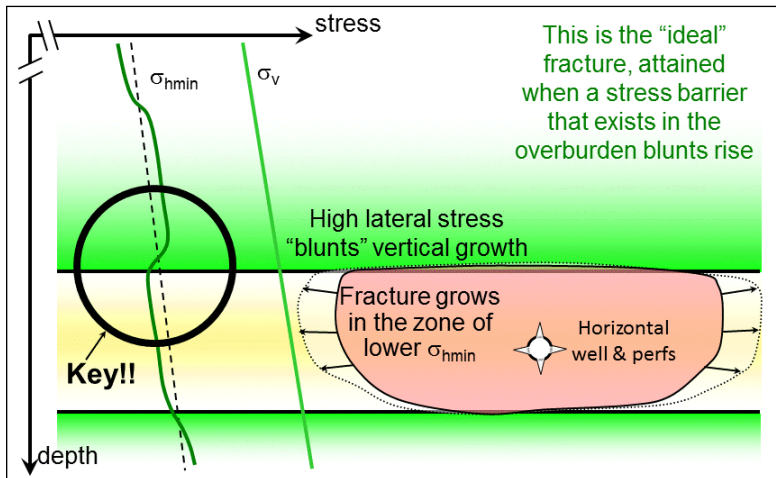

Figure 33. A stress barrier at the top of the prospective horizon blunts vertical fracture growth.

The details of the lateral stress distributions in the Green Point Formation or indeed in any parts of the stratigraphic column in the Port au Port Peninsula and Bay areas have not been measured, or are not public knowledge at the present time if any measurements were made in the few exploratory wells that have been drilled. Part of the exploration and evaluation activities of this play if more drilling takes place would be using small-scale trial fracturing to measure the stresses, combined with dipole and quadrupole acoustic logs to help extrapolate measurements and determine preferred stress directions in the ground. These small-scale HF trials use volumes that are a small fraction, perhaps less than 1%, of a HF well stimulation episode, and are used deliberately to estimate the horizontal stresses in the sedimentary column. If the favourable condition of a stress barrier exists, similar to the condition shown above, concerns about and significant vertical fracture growth above the target stratum can be set aside. Also, such a case leads to excellent lateral fracture growth, which means that development wells can be placed farther apart, with a large positive economic impact. If the other condition is found to occur, with a lower horizontal stress in the cap rock that promotes vertical fracture growth, then companies will have to modify their HF strategies to minimize wasting fluids, and they will have to drill wells at closer spacing and with smaller fracturing volumes to achieve reasonable recovery factors.

Permeability Blunting of Fracture Rise

The permeabilities of different strata are different because of pore structure and the rock mass discontinuities (joints, bedding planes, microfissures). If there are more permeable beds overlying the HF zone, even thin ones, that can drain the HF fluids, the tendency for vertical fracture growth will be reduced. This effect is also called fracture “blunting”, and the process is shown in Figure 34.

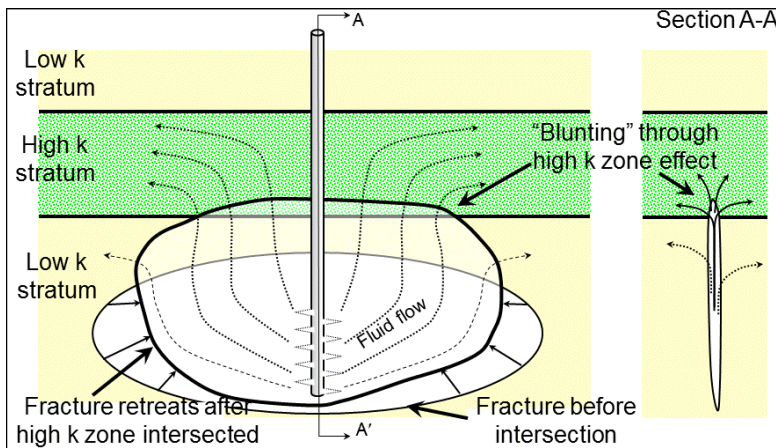

Figure 34. Fracture blunting because of increased fluid leak-off.

In this scenario, a fracture initiates in the target formation and propagates in a normal manner until it makes contact with the more permeable zone. At this point, the leak-off rate suddenly increases significantly because the fluid drains more readily into the high permeability zone. This not only blunts vertical growth, it generally terminates horizontal growth because the fluid can now simply leak off into the surrounding rocks, and the fracture treatment may even cease to be effective. However, if the fracturing fluid escapes laterally in the permeable zone, and all tendencies for fluids to migrate upward are lost, such a condition further reduces the potential for fracture rise

To address this issue, which is not a favourable condition for MSHF well stimulation, the company will revisit their fracture design program, adding more fine-grained particles to plug the permeable zone during active fracturing, increasing HF fluid viscosity to reduce leak-off, adding gas to the fracture fluid so that the small bubbles tend to block the more permeable zone pores, reducing the volumes of fluid used, and so on.

As with the distribution of the lateral stresses, the distribution of the permeability in the zones at the top of the Green Point Formation and in a few hundred metres above are not well-defined at the present time. Note that it is not necessary that such a zone have a large permeability (i.e., larger than 1 Darcy); it is sufficient to have a modest permeability such as 0.01 to 0.1 Darcy over a vertical extent of 50 m to serve as a blunting zone that inhibits vertical fracture propagation.

Depletion Effect

Questions have been posed as to whether fluids could rise from an exploited zone, or whether later re-stimulation activities could lead to a greater potential for fluids to move toward the surface. With a high degree of certainty, the following conclusions can be made:

- The exploited zone – the prospective zone or zones in the Green Point Formation – would be depleted in pressure as a result of the production of oil and gas. As a result, it would no longer be a pressure source, but a pressure sink, and fluids would thus tend to move toward the pressure-depleted zone, not away from it. Hence, risks of fluid migration toward the surface are unequivocally reduced by production, not increased.
- Pressure depletion also reduces the lateral total stress in the target formation, creating a stress barrier in the caprock if it is not depleted. This phenomenon is well understood in the oil and gas industry; it takes place because as one depletes the productive zone, it shrinks a little bit (a fraction of 1% in the case of the Green Point Formation), and therefore sheds some of its lateral stress, but this stress must be carried somewhere, so it is transferred to the non-depleted strata above and below the depleted zone.
- Subsequent re-stimulation activities (re-fracturing) that would undoubtedly take place in almost any development scheme would therefore tend to be more confined to the production zone because of the increased stress in the caprock; any tendency for fracture rise would be reduced, perhaps even eliminated, so risks of HF fluids going much beyond the top of the depleted zone during re-stimulation becomes extremely small, essentially zero.
- Pressure depletion increases the compressive effective stress (the stress transmitted through the rock matrix, as opposed to the fluid pressure) across natural fracture surfaces. Hence, the natural fractures (vertical joints) in the upper parts of the Green Point shale or in the adjacent caprocks will experience an increased compression, and this has the effect of reducing the aperture of the vertical joints, and thus reducing the joint conductivity (the ability to transmit fluids).

For example, if a HF treatment or re-stimulation takes place in a well or a zone already partly depleted (pressure reduction) as the result of previous production from the well or production from that zone through offset wells, there will have been a reduction in horizontal stress in the target zone, and a concomitant increase in the horizontal stress

in the caprock.¹¹⁸ This creates a stress barrier if one did not previously exist, as shown in Figure 35. This behaviour is widely observed in practice: HF stimulation of depleted zones or HF re-stimulation of wells that have already produced oil and gas so that the formation pressure is now well below the original pressure is characterized by excellent containment.

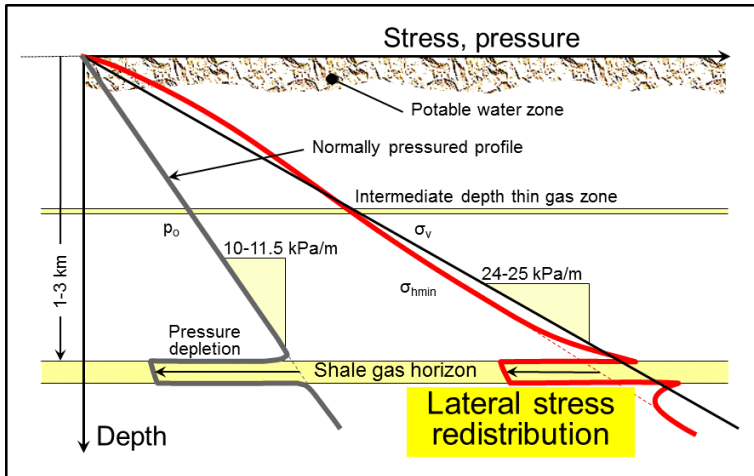

Figure 35. Depletion decreases lateral stresses, favouring lateral fracture growth in the depleted zone when HF restimulation takes place.

It can be shown for a linear elastic rock mass that pressure depletion (Δp) will result in a reduction of the lateral stress (σ_{hmin} or σ_3), approximately according to the following relationship: $\Delta\sigma_{hmin} = -\Delta p(1 - 2\nu)/(1 - \nu)$, where ν is the Poisson's ratio of the rock mass. So, for example, if the pressure depletion is 10 MPa and Poisson's ratio is 0.15 to 0.2 (reasonable value for the Green Point Formation), then $\Delta\sigma_{hmin} \approx 7-8$ MPa. Clearly, this is a substantial reduction in the lateral stress that was previously estimated to be about 60 MPa at a depth of 2.5 km, and of course it means that subsequent re-fracturing will be much better contained within the depleted horizon than was the case for the primary stimulation. This means that the tendency for fracture rise is more and more reduced with exploitation (continued pressure depletion) of the target formation. In the Green Point strata, there have as yet not been production episodes resulting in any depletion. There is no evidence of significant overpressuring (p_o more than 20% higher than the pressure of a fresh water column), so one may assume that this is not a large issue. If the pore pressures are depleted by 10 MPa as in the example above from the original value previously estimated to be 27-32 MPa at a depth of 2.5 km,

- The total horizontal stress in the zone decreases by about 7-8 MPa, improving fracture containment.
- The effective stress increases, tending to squeeze natural and induced fractures tighter, making them less conductive, restricting vertical flow.
- The horizontal stress in the overlying strata increases by some amount (5-8 MPa?), creating a barrier to upward fracture propagation
- The reduced pore pressure creates a condition where fluid flow is now everywhere directed toward the producing well, and upward flow of fluids becomes impossible.

In summary, depletion reduces all future risks of vertical fluids migration through impacts on the pressure distribution at depth, on the magnitude of lateral stresses at depth, which affects future fracture re-stimulation, and on the hydraulic conductivity of existing joints in the unproped part of the formation and in the overlying caprock.

¹¹⁸ Warpinski N.R., Schmidt R.A., Northrop D.A. 1982. In-Situ Stresses: The Predominant Influence on Hydraulic Fracture Containment. *Journal of Petroleum Technology* **34(03)**, 653-665.

Stress Conditions and Hydraulic Fracturing at Shallow Depths

Stresses in the ground in strong and stiff rocks can be locked in for hundreds of millions of years. The last tectonic event in this area of Western Newfoundland seems to have been a compression event, creating thrust faulting and inversion in the region. If there has been no subsequent extensional episode, and this seems to be the case, some proportion of the high horizontal stresses that acted during this compression will still be in the rocks. Stresses control HF orientation and propagation, and shallow (300-800 m) hydraulic fracturing in uplifted and eroded basins has shown that the magnitudes of stresses at shallow depth cannot be predicted from elastic theory, extrapolated from data obtained at greater depth, nor measured reliably from geophysical logs; small scale hydraulic fracture tests are needed. However, it is not only tectonic compression that can lead to a high horizontal stress at shallow depth.

The Port au Port Peninsula and Bay area has been tectonically quiet for several hundred million years, but throughout this time it has undergone slow erosion and uplift. These processes also have affected the stress state, and understanding the stress distributions that arise in such basins is important for assessing the behaviour of hydraulically induced fractures. If during the active propagation phase a rising fracture encounters a transition to a different stress condition, it will change orientation. Because near the surface in these cases the vertical stress – σ_v – becomes less than the two principal compressive horizontal stresses, induced fractures will become horizontal. Because there is an absence of stress data from Western Newfoundland at this time, the only method to estimate the magnitudes of the stresses is by analogy to other cases.

Many onshore basins, such as the Western Canada Sedimentary Basin, the Michigan Basin, and the Wind River Basin¹¹⁹ in Wyoming, were formed by sedimentary processes in a subsiding basin that later experienced tectonic compressive loading (as in Alberta), and then later become tectonically quiet, experiencing tens of millions of years of slow erosion and uplift. Other basins, such as the Michigan Basin, never experienced significant tectonism, but underwent slow relative uplift so that erosion then took place for several hundred million years. In all such tectonically quiet basins that have been more recently dominated by erosion, the horizontal stresses have been affected substantially. Because of the rigidity of rocks, when stress is removed in the vertical direction through erosion, the stress drop in the horizontal direction is far less, perhaps half to even a quarter of the change in vertical stress. In all such cases, providing that there has not been a renewal of tectonic loading (extensional or compressional), a layer close to the surface will become more highly stressed horizontally than vertically. This leads to a surface layer, from perhaps 200 m to as much as 1000 m thick, where horizontal stresses are greater than the vertical stress ($\sigma_v = \sigma_3, \sigma_{hmin} > \sigma_v$).

This condition is shown in Figure 36 for a site northeast of Medicine Hat, AB, where many careful measurements in shallow natural gas sandstones and surrounding rocks led to a conclusion that the depth at which σ_v becomes σ_3 (instead of σ_{hmin}) is between 340 and 420 m. The uncertainty arises because of measurement limitations, but also because there are differences in the elevation of the ground surface of about 80 m in the region from where the data came, so a range of this magnitude is considered perfectly normal. Note in the figure the orientation of the hydraulically induced fractures that were used to stimulate shallow gas wells in the region: above a depth of about 350 m, all the measurements indicated horizontal fractures, which is the expected condition if $\sigma_v = \sigma_3, \sigma_{hmin} > \sigma_v$. In this case, the change in the direction of σ_3 from horizontal ($\sigma_{hmin} = \sigma_3$) to vertical ($\sigma_v = \sigma_3$) affects the success of fracture stimulation, as vertical fractures can contact more of a formation than horizontal fractures.

Over one hundred fracture gradient measurements in the Pavillion Field in the Wind River Basin, Wyoming, carried out by Encana Energy and published in a report to the Wyoming Oil and Gas Conservation Commission (the state regulatory agency) show a similar trend.

¹¹⁹ These basins are mentioned because the author has worked professionally in these basins and studied the stress distributions with depth.

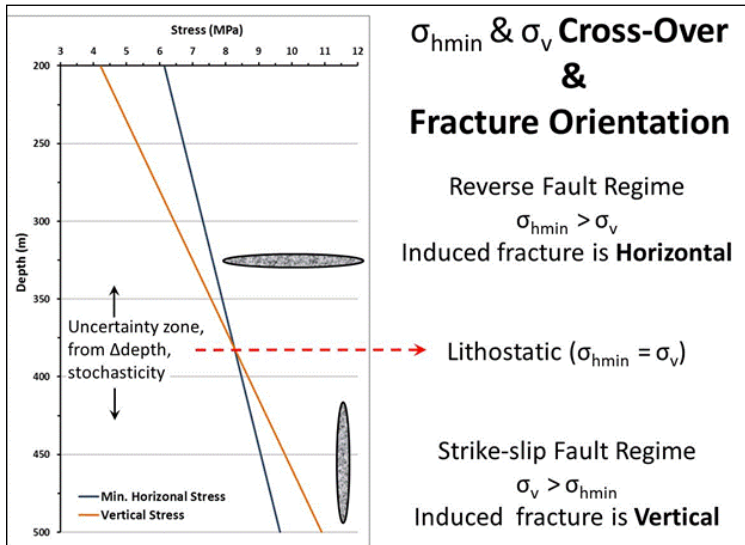

Figure 36. Stress and fracture orientation in an uplifted, eroded basin, north of Medicine Hat, Alberta.

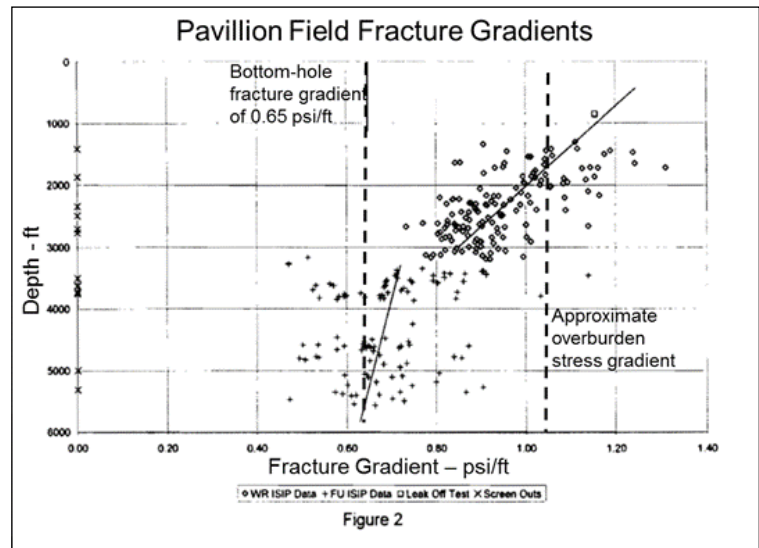

Figure 37. Measured fracture gradients Pavillion Field, WY (Encana Energy).

In the Wind River Basin data plot (Pavillion Field) shown in Figure 37, the overburden stress is the right-hand vertical line, and the cross-over point is at a depth of about 1500' - 2500' (450-750 m). As in the Medicine Hat, AB, case shown in Figure 36, induced hydraulic fractures above this depth will propagate horizontally, not vertically, with a minimal tendency to rise during the short high pressure injection period. The specific location of the cross-over point depends mainly on the amount of erosion that has taken place since the strata were affected by compressional or extensional tectonic activity. This type of stress distribution was pointed out for the Western Canada Sedimentary Basin about 40 years ago,¹²⁰ and it appears that the condition of higher horizontal stress in the upper few hundred meters of eroded, uplifted basins is a broadly general condition and should apply to Western Newfoundland as well. However, the rocks in Western Newfoundland are much denser and stiffer than the sediments in the Alberta and Wyoming cases, and the soft rocks in these examples are perhaps not the best analogues.

There are excellent analogues in the Michigan Basin, and specifically in Ontario, for strata of the same geological ages (Lower Paleozoic: Ordovician and Silurian age) that are not deeply buried at present. In fact, many of the strata

¹²⁰Dusseault M.B. 1977. Stress state and hydraulic fracturing in the Athabasca Oil Sands. *J. of Canadian Petroleum Technology* **16(3)**, 19-27.

in Ontario are of the same age and stratigraphic position as the Anticosti Basin and other sub basins in the region because they were all laid down in the same large sedimentary basin several hundred million years ago.

The strata in Ontario were not significantly affected by the compressive thrust faulting of the Appalachian mountain-building episode: there are no thrust faults in the strata, and the dip of the strata is very gentle, approximately 1°-2°. The normal faults do not penetrate significantly through the younger Silurian sediments nearer the surface, so it seems that the tectonic activity that created the faulting is no later than the Silurian in age.

As in Western Newfoundland, the strata in Ontario were buried perhaps 1-2 kilometer more deeply than at present, and during burial underwent densification to quite low porosities, particularly in the shales and carbonates (generally less than 5-6% porosity). The rocks became very stiff, and natural fractures (joints) formed as the strata were buried and underwent diagenesis before being uplifted.

After several hundred million years this part of North America was uplifted again at about the beginning of the Cenozoic Era but without renewal of tectonic activity. The Appalachian Mountains as they are today were in large part formed because of erosion within the last 200-250 million years, and this erosion continues to this day.

In Ontario, the horizontal stresses at shallow depth (0-50 m) can be several times the vertical stress, leading to features such as pop-ups (compressive buckling leading to chevron-shaped rupture features).¹²¹ High horizontal stresses lead to some operational problems during rock quarrying, and issues of creep and instability in tunnelling under cities such as Toronto and Buffalo.¹²² This zone of high horizontal stresses extends down at least several hundred meters below the surface, although the specific cross-over point has not been determined.

From energy conservation and work minimization principles in mechanics¹²³, during active fracturing, more energy is expended in forcing a unit mass of water vertically than forcing it horizontally if the minimum stress is vertical. This leads to the conclusion that a propagating fracture tip rising through a rock mass will reorient itself so that the fracture plane is normal (at 90°) to the smallest compressive stress, and rising hydraulic fractures will not propagate vertically much above the cross-over point (several 10's of meters maximum) before becoming horizontal. This is likely to be the condition in Western Newfoundland and this is consistent with observations of natural dikes and sills in other similar geological environments.

Figures 38 and 39 show the results of some HF experiments carried out in a 1×1×0.8 m rigid sandbox.

In Figure 38, the sand was densified and then fractured with a blue-dyed viscous fluid: a vertical fracture was generated, quite symmetric around the wellbore. The height-to-width ratio in this case where $\sigma_v = \sigma_1$ is about 1.5:1, and the tendency toward more vertical growth than lateral extension is quite clear. The pressure gradient in the fracturing fluid was 10 kPa/m; the lateral stress gradient in the sand was about 16 kPa/m. The blue colour extends beyond the actual fracture surface because of flow through the permeable sand

Figure 39 has identical conditions except that the sand was surcharged to simulate burial to a depth of about twice the sandbox depth and then the surcharge was removed to try and emulate the loading/unloading behaviour that takes place in a basin that is undergoing erosion and slow uplift. The induced fracture is completely horizontal because in this case, as the result of the loading history, $\sigma_v = \sigma_3$. (The blue colour above the base of the sandbox in Figure 39 arises

¹²¹ Karrow P.F. 1993. Bedrock Stress Release Features on Manitoulin Island, Ontario. *Géographie Physique et Quaternaire* **47(3)**, 389-393.

¹²² Lo K.Y. 1978. Regional distribution of in situ horizontal stresses in rocks of Southern Ontario. *Canadian Geotechnical Journal* **15(3)**, 371-381.

¹²³ The principles of energy conservation and minimization of work are fundamental to all processes in mechanics, and allow analysis and predictions to be made. A natural process will adopt a configuration that involves work minimization, and this means that induced fractures must be thin and normal to the direction of σ_3 , and propagate in such a manner as to maximize surface area for a volume of fluid injected.

from fluid flow through the sand; the actual fracture is right at the base, at the perforated interval.) This is visual proof of the importance of loading history and the influence of the principal stress directions on fracture propagation.



Figure 38. Vertical fractures develop when $\sigma_{\text{hmin}} = \sigma_3$.



Figure 39. Horizontal fractures develop when $\sigma_v = \sigma_3$.

Some important conclusions can be drawn from this section:

- Western Newfoundland, similarly to other uplifted basins, almost certainly has a shallow in situ stress condition that predicates the propagation of horizontal fractures during HF (i.e. $\sigma_v = \sigma_3$).
- The depth to the stress transition zone is probably much deeper than several hundred metres; more likely it is close to 1000 m because of the additional effect of the tectonic compression history.
- It is reasonable, in the absence of measurements, to assume that hydraulic fractures induced at depths of 1000-3500 m will tend to propagate vertically.
- If fracturing takes place at shallow depths such as 1000 m, a vertical fracture rising 400-800 m to intersect the shallow groundwater would be impossible with this $\sigma_v = \sigma_3$ condition, considering the volumes needed.
- Risks of HF rise above the BGWP in the Port au Port area are considered to be, in the context of what is known and what can be reasonably surmised at this time, as close to zero as it is possible to estimate.

Nonetheless, these conclusions have not been unequivocally proven in the field, and therefore the following recommendations are made:

- Future exploration activity should include determination of stress orientations and magnitudes.
- The methodology should be based on direct measurements using MiniFrac™ or similar approaches in open-hole conditions, supplemented with dipole or quadrupole acoustic geophysical logging, borehole breakouts analysis (borehole ellipticity), and core analysis if possible.
- A geological stress history study for public distribution should be compiled once some additional information becomes available from exploration activity.
- The geology of Western Newfoundland is complex and therefore caution should be exercised in excessive lateral extrapolation of stress data; there may be, for example, regions where ancient karst activity or old faults where stresses could vary locally from the regional stress fields.

Lateral Fracture Migration during HF and Offset Well Intersection

Incidents where HF fluids have propagated laterally to offset wellbores during active injection and interacted with shallow sediments appear to be extremely rare, but several cases have been reported.¹²⁴ The reduced lateral stress associated with depletion aids fracture containment within the reservoir for later re-stimulation activities, but this also means that if large HF injection is taking place relatively nearby within the reservoir, there is a tendency for the fractures to propagate toward the low stresses around the old production well. Of interest perhaps are several documents that have been posted since the well intersection event described in the ERCB (2012) report took place. First is a new set of regulatory requirements to reduce the probability of offset well intersection,¹²⁵ second is an industry consortium document on recommended practices from the Drilling and Completion Committee, Alberta.¹²⁶

This is not a significant issue in Western Newfoundland because there are no previously existing long-term production wells. Furthermore, it is clear that this issue can be successfully regulated and the risks of groundwater interaction from this mechanism mitigated if any issues are suspected.

¹²⁴ ERCB (Energy Resources Conservation Board) 2012. Midway Energy Ltd. Hydraulic Fracturing Incident: Interwellbore Communication January 13, 2012. ERCB Investigation Report filed Dec 2012, 11 p, available on the Alberta Energy Regulator website. www.aer.ca/documents/reports/IR_20121212_Midway.pdf

¹²⁵ ERCB Energy Resources Conservation Board 2013. Directive 083: Hydraulic Fracturing – Subsurface Integrity. 14 p, available on the Alberta Energy Regulator website: www.aer.ca/rules-and-regulations/directives

¹²⁶ Drilling and Completion Committee, Alberta, 2013. IRP 24 FRACTURE STIMULATION: INTERWELLBORE COMMUNICATION. Available from www.enform.ca/resources/detail/29/dacc-irp-volume-24-interim-fracture-stimulation-interwellbore-communications (Other IRP documents are available from www.enform.ca)

ENERGY WELL INTEGRITY¹²⁷

Cased, cemented wells are designed and drilled to access various types of resources beneath the surface of the Earth. Groundwater, oil and gas, thermal energy, salt, sulphur, and even deeply-buried leachable mineral ores (Nacholite, Dawsonite, some Uranium compounds, etc.) are accessed through designed wellbores. Deep environmentally secure disposal of aqueous liquids and even fine-grained solid wastes can be achieved by deep well injection, but design and operation of these various types of wells is a vast topic. Hence, this discussion paper on Energy Well Integrity will focus on typical onshore unconventional oil or gas wells, which are generally similar to wells used for conventional oil or coal bed methane production. The major topics covered in this paper are well design, construction, use and decommissioning. Issues of cementing practices and gas migration pathways are given special emphasis because they are key aspects in establishing and understanding well integrity.

Section Summary

Unconventional oil and gas development using modern cementing and completion techniques usually benefits from good wellbore integrity, but, as in any industrial activity, there will never be a 100% success in sealing all wellbores against all possibilities of future leakage. Technology advances have helped reduce the incidence of leaking wells and now provide better quality control, leak detection capabilities, and improved methods for rectifying leakage issues, once properly identified. The most common long-term well integrity issue after wellbore decommissioning is slow gas seepage around the external casing. The consequences of such leaks, though negative from a climate change perspective, are not a great public health threat because natural gas is not a toxic substance, the number of wells that display high-rate leaks is low, and the overall average leakage rates appear to be low. When leakage is identified, appropriate corrective measures involving well re-entry can rectify problems. Though rigorous statistics remain elusive (and this should be studied quantitatively), it seems that the number of significant problems encountered in Alberta and British Columbia, relatively mature regulatory environments, is not large.

Because possible future unconventional resource development in western Newfoundland or even in the Gulf of St Lawrence (Old Harry prospect for example) would take place using modern technology with multiple wellbores installed at each drilling site (or platform), it is a relatively straightforward task to establish good regulatory practices (guidelines and enforcement), quality control, and monitoring to ensure that the site is geologically understood, that wells are properly installed, and that well decommissioning is performed according to best practice guidelines. The establishment of an appropriate monitoring and regulatory system for onshore hydrocarbon development in Newfoundland to complement the existing offshore regulatory experience would take place before any large-scale unconventional oil and gas resource development occurs. Hence, risks related to energy well integrity will be reduced to values considered appropriate, given the consequences of such occurrences. More specifically, it seems clear that the public health consequences and other risks associated with some natural gas leaking from energy wells is small, given that natural methane seepage into groundwater has been occurring forever in some regions, without apparent health consequences.

Geological conditions in the region of the Port au Port Peninsula and Bay are extremely stable. Although the magnitudes and orientations of the principal stresses remain partly unquantified at present, there is no tectonic activity, and the region is quiet from a seismic point of view. This should lead to a low incidence of poor wellbore integrity for the following reasons:

¹²⁷ This section is a modification of a general discussion paper written by the author for the Nova Scotia Hydraulic Fracture Review Panel that submitted its report to the Government of Nova Scotia in August 2014. The original paper and other parts of the Panel's report may be found at: energy.novascotia.ca/sites/default/files/Report%20of%20the%20Nova%20Scotia%20Independent%20Panel%20on%20Hydraulic%20Fracturing.pdf

- Moderate tectonic stresses and dense competent rock in the subsurface mean that wellbore quality will be excellent, giving good stability with little drill-hole sloughing. This will facilitate the installation of high quality well casings, and therefore result in fewer cases of leaking wells in the long-term. As wells are drilled in the area, the oil companies will soon find ways to become more efficient in installing high quality boreholes, as there is a strong economic incentive to do so.
- There appear to be few large gas sands or other significant sources of gas at more shallow depths above the Green Point Formation that might lead to problems with long-term gas migration behind the casing. This must be confirmed in more detail, and if such zones are found, it might be taken into account in the well design and installation protocols.
- Oil and gas in the Green Point strata are likely to be sweet (little or no associated hydrogen sulphide gas), making all operations easier and casing life longer, compared to some other jurisdictions. Again, this conclusion comes from knowledge from other adjacent basins (New Brunswick, Moncton Subbasin, Anticosti Island), and must be verified by drilling.

Introduction to Well Integrity

Deep wellbores (below the BGWP) to provide access to various types of resources beneath the Earth's surface are designed, drilled, cased and cemented, exploited for some time, then decommissioned. Groundwater, oil and gas, thermal energy (geothermal energy), ordinary salt and other salts such as KCl or Nahcolite, sedimentary uranium and other deeply-buried leachable mineral ores, can all nowadays be accessed and exploited through designed wellbores. The focus in these pages is on wells drilled through sedimentary rocks to access deep resources of natural gas and oil in onshore operations. There are a number of stages in the life of an Energy Well.

Well Design is carried out through a process that involves assessment of the subsurface geology, knowledge of the shallow groundwater hydrology (e.g. the regional value of BGWZ), understanding of the nature of the fluids to be produced (oil, natural gas, water), and knowing the nature of the service to which the wells will be exposed (temperatures, pressures, fluid chemistry). This engineering design process is informed by decades of experience for millions of oil and gas wells worldwide, over 500,000 in Canada alone.

The western part of Newfoundland has been penetrated by a small number of deep wells in the Port au Port region, but the complex tectonic history means that the nature of the rocks and the geological disposition of the strata are not nearly as well understood as, for example, in Anticosti Island, where there have been only a few wells drilled over a much larger area. This is because the geology in Anticosti Island had no tectonic episodes after deposition, so all the strata are relatively consistent from place to place, and construction of a good geological model from drilling and seismic work is straightforward. This drilling and logging data in Anticosti Island have been extrapolated by onshore and offshore seismic surveys, which allow anomalies to be identified and therefore action taken to make sure that the drilling program and well design are properly planned to mitigate risk. The same would be done in Newfoundland, but the geological complexity means that much more effort is necessary to generate a well-defined geological model. This is a natural part of the exploration program if moves toward commercialization are ever made. The ongoing improvement of the geological model and the approval of well designs are invariably done in coordination with the regulatory agency responsible for protecting the financial and environmental interests of the various stakeholders.

Once a well design has been approved to meet specific needs (an exploratory well, a development well, a monitoring well...), the chosen surface site is prepared, a drilling contractor hired, and **Well Construction** begins. A drill rig is erected, and the borehole is advanced by rotating a drill bit at the bottom of the drill pipe, while circulating out the drill cuttings using a drilling fluid pumped down the center of the drill pipe. During this process, the borehole is protected through the installation of a set of concentric steel casings cemented into place. Drilling and well construction practices have evolved over many decades, as experience has been gained in different geological conditions and

as new materials and techniques have been developed.¹²⁸ For example, using modern practices and polycrystalline diamond bits, a vertical three kilometer deep borehole that took six weeks to drill in 1985 in Alberta might now be completed in two weeks. Also, more and more, horizontal wells are used for the final drilled section to provide access to a long section of the reservoir, an approach that means that fewer wells have to be drilled than in decades past. Standards for casings and cement have also changed: in some jurisdictions it is still permitted to leave some upper sections of casing uncemented, leaving the rock exposed to the open (but fluid-filled) borehole, but new regulations generally require that all steel casings be cemented to surface. In many cases, companies are installing "premium thread" steel casings or higher grade steels, either voluntarily or because of changing regulatory guidelines, to reduce the incidence of well integrity issues such as slow gas leaks at connections.

During well construction, after a steel casing is cemented into place into the borehole, then another wellbore section may be drilled and cased, until the last string, which is called the production string, is installed. In the case of shale oil wells in the Green Point Formation in the Port au Port regions, the final section will most likely include a horizontal section from 1-3 km long that has to be completed properly to allow good production rates. Depending on issues such as borehole stability problems or high overpressures in some regions of the world, there may be several casings. In the Green Point development, oil companies would install a surface casing and a production casing, but there may be need for an intermediate casing, depending on various factors that remain ill-quantified at present (lost circulation zones, gas zones, unstable zones, etc., if these exist).

Conventionally, perforation technology was used to create holes through the steel casing and cement of the final string – the production casing – which used to invariably be vertical, to allow direct access to the target strata that contain the oil and gas. This is part of **Well Completion** practices, which have evolved to include not only perforating, but various well stimulation processes such as acidizing and HF that are designed to enhance access from the steel-cased well to the potentially productive geological formations. New stimulation and production technology that avoids cementing the final, horizontal section of the energy well may be installed instead of standard cemented steel casing. This special equipment also allows access to the productive formations and permits more efficient well stimulation methods during the completion process.

HF stimulation^{129,130} increases the surface contact area of the formation so that fluids may be produced more effectively – leading to a commercially viable recovery rate and a higher recovery factor (% of the resource ultimately produced). Since the HF technique was first introduced in the late 1940's, more than a million wells have been hydraulically fractured worldwide, most of them in the USA. About 175,000 wells have been hydraulically fractured in Alberta¹³¹ starting with the Pembina Oilfield in the early 1950's. In Québec, a number of wells in the St Lawrence Lowlands have been hydraulically fractured on a limited basis, but in the Anticosti region, the drilling of long horizontal wells and extensive HF has not yet been issued permits, nor has this been permitted in the Port au Port region. It is important to understand that current multi-stage HF approaches in horizontal wells involve much larger fluid volumes and injection rates, compared even to the period 2000-2005, and the technology continues to evolve. Some have speculated that, in the future, 95% of all wells in North America will be hydraulically fractured, and the technology continues to advance, with numerous articles on optimization and planning of such wells.¹³²

Well Operation comprises the period of time from initiation of fluid production to the end of commercially viable

¹²⁸ Cochener, J. 2010. Quantifying Drilling Efficiency. US EIA (Energy Information Administration). 16 page discussion paper available on the EIA webpage www.eia.gov/workingpapers/pdf/drilling_efficiency.pdf

¹²⁹ Valkó P., Economides M.J. 1995. *Hydraulic Fracture Mechanics*, John Wiley & Sons Ltd., Chichester, England.

¹³⁰ Yew C.H. 1997. *Mechanics of Hydraulic Fracturing*, Gulf Publishing Company, Houston.

¹³¹ environment.alberta.ca/04131.html; www.capp.ca/aboutUs/mediaCentre/NewsReleases/Pages/governments-regulate-shale-gas.aspx; www.oilandgasinfo.ca/fracopedia/hydraulic-fracturing-explained/

¹³² Yu W., Sepehrnoori K. 2013. Optimization of Multiple Hydraulically Fractured Horizontal Wells in Unconventional Gas Reservoirs. *Journal of Petroleum Engineering*. Hindawi Publishing, Number **151898**, 16 p.

production. During this time, the well may be re-stimulated with HF to encourage production, acidized or subjected to other actions to clean the near-well environment and remove blockages, and other activities. There may be periods when the well is shut-in for one of a number of technical or commercial reasons. For example, the well may be held in an inactive status to conform to agreed-upon limits (prorated production contracts), awaiting a decision to re-stimulate or develop another formation intersected by the wellbore, waiting for equipment availability, left for future new technology or enhanced oil recovery method implementation, or awaiting decommissioning. The well at the tip of Shoal Point is inactive and suspended, awaiting further action; it has not been decommissioned.

Once the resource that can be accessed by a single well has been developed and depleted, a stage that can vary from a decade to 50 years, the well must be decommissioned properly and the ground rehabilitated. **Well Decommissioning**¹³³ involves making sure that the wellbore possesses integrity (no leaking of fluids), rectifying any problems that might exist, then placing a series of sealing plugs, usually only within the innermost open part of the well, to insure that there is no pathway for fluids to migrate from one zone to another, or to migrate up to the surface. Decommissioning implies that all surface disturbance that does not constitute infrastructure of local value (access roads for example) be returned to stipulated standards set by regulatory agencies.

Well Integrity as used in this discussion includes integrity internal and external to the casing strings; that is, maintaining the initial goal of the cemented steel casing strings to isolate the strata and prevent unwanted fluid flow either inside or outside of the casings during production and after decommissioning. The cemented casings installed during the well drilling and completions stages are specifically placed to control fluid flow. During active production from the energy well, the company will be more concerned with internal and external well integrity issues in or close to the target formation, and this involves many other topics – tubing condition, packer reliability, threaded connection integrity, etc. This type of integrity is far more easily monitored and managed than post-decommissioning integrity because the well is active when such issues of internal integrity and inter-formational fluid migration might arise. Hence, intervention to rectify a problem such as a casing breach or leakage behind casing is more straightforward.

These stages of well design, construction, operation, and decommissioning, take place within a regulatory framework that is a provincial responsibility. **Regulatory Guidelines** have been developed in all provinces that have a significant oil and gas industry, although by virtue of the size and age of its oil industry, Alberta's regulatory body, the AER (Alberta Energy Regulator), is the senior one in Canada. Many provinces take advantage of the vast amount of work that has gone into development of AER regulatory guidelines.¹³⁴ Modern regulatory bodies in Canada have broad authority for the setting and enforcement of guidelines covering all active wells, suspended wells (inactive but not plugged and decommissioned), and decommissioned wells. Complete documentation of Canadian practices can be downloaded from the websites of the major regulatory agencies.¹³⁵

Wells drilled to access unconventional oil and gas resources are not significantly different from other wells used in the oil and gas industry around the world. However, the relatively recent developments of long horizontal wells, multi-stage high-rate hydraulic fracturing (MSHF), and multi-well pad design are novel, compared to the old paradigm of one vertical wellbore per surface site and a limited volume of fracture injection, so consideration should be given to the impacts of changing development practices.

¹³³ The term "decommissioning" is preferred to the far more common term "abandonment" because in modern practice, the well site and wellbore are never fully abandoned; the well is plugged, but in principal it can be accessed and rehabilitated if problems are found to occur.

¹³⁴ An idea of how the oil and gas industry is regulated in Canada can be obtained by studying the AER website and their various guidelines and enforcement actions: www.aer.ca/ As an example, the rules for land reclamation can be found at this webpage: www.aer.ca/abandonment-and-reclamation/reclamation

¹³⁵ For example: British Columbia: www.bcogc.ca/industry-zone/documentation; and for Alberta: www.aer.ca/rules-and-regulations/directives

Well Design

The design of an unconventional oil or gas well requires decisions in advance for the size of the steel casings. This depends on many factors; several of the most important are listed here:

- What is the desired diameter of the final wellbore? Different completion technologies may require different borehole diameters for the installation of well completion equipment.
- What is the depth required for surface casing installation? This may be controlled by the local depth to the Base of the Ground Water Protection zone (BGWP), perhaps defined by the geochemistry of the groundwater, as is done in Alberta for example.¹³⁶ On the other hand, it may be a depth stipulated solely by regulation (e.g., 150 m from surface).
- Are there formations between the surface casing depth and the target formation that are prone to instability during drilling and must therefore be protected with an intermediate casing string?
- Are there zones that will be encountered during drilling that have significantly higher pressures than predicted by the hydrostatic pressure gradient (10 MPa/km) and present risks of blowouts during drilling?
- What is the target formation and depth of the well, and if a horizontal leg is to be drilled, where will it be and how long will it be?
- Will the horizontal leg completion be fully cased and cemented or will a multiple inflatable packer system be used?
- Once the design is finalized, the permit application for regulatory approval is filed. The design details must allow for some flexibility; for example, if the length of the horizontal well is designed to be 2.0 km, drilling difficulties may truncate this length somewhat.

Two possible designs for new wells targeting unconventional resources in Western Newfoundland are sketched in the following diagrams, the first – Figure 40 – including a long horizontal section in the producing horizon, the second design only considering a vertical array of casings.

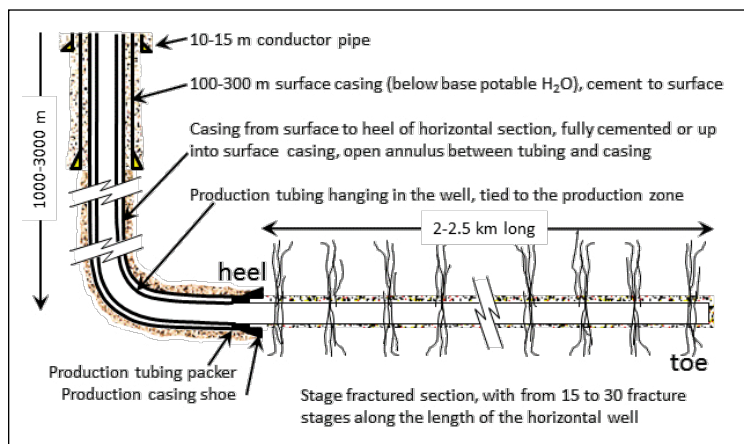

Figure 40. A typical shale oil well with a long horizontal section and no intermediate casing string.

¹³⁶ Alberta defines the BGWP as 4000 ppm tds (parts per million total dissolved solids such as sodium chloride). "Water containing TDS concentrations below 1000 mg/litre is usually acceptable to consumers..."; quote from WHO 1996, *Total dissolved solids in drinking-water*. In Guidelines for drinking-water quality, 2nd ed. Vol. 2. *Health criteria and other supporting information*. World Health Organization, Geneva, 1996. WHO/SDE/WSH/03.04/16.

The horizontal configuration shown in Figure 40 has become a standard design for unconventional energy wells, but vertical wells are still used (Figure 16) if the resource is in a very thick zone (hundreds of metres) and is best accessed through a number of perforated zones and hydraulic fractures spaced vertically along the wellbore. In Western Newfoundland, large volumes of gas at depth and pressures far above hydrostatic pressure (>12 MPa/km pressure gradient) do not likely exist. Hydrostatic pressure is considered "normal", in contrast to the condition of "overpressure", which refers to pressures substantially greater than the pressure from a static column of water. Thus, in contrast to offshore Nova Scotia or Newfoundland where pressures far above hydrostatic are well-known, it is not necessary to take exceptional measures onshore to guard against a gas blowout; standard well designs and safety measures such as conventionally rated blowout preventers are sufficient to address the small risk of a blowout. If parts of the Green Point shale are somewhat overpressured, the probability of a loss of well control remains small because the permeability of the strata is low, therefore large volumes of pressurized fluids cannot enter the wellbore suddenly.

The vertical well in Figure 41 shows more modern completion practices on the left, and practices that are no longer considered appropriate on the right. Specifically, high-quality cement must be brought to surface or far into the previous steel casing string to give a higher assurance of well integrity.

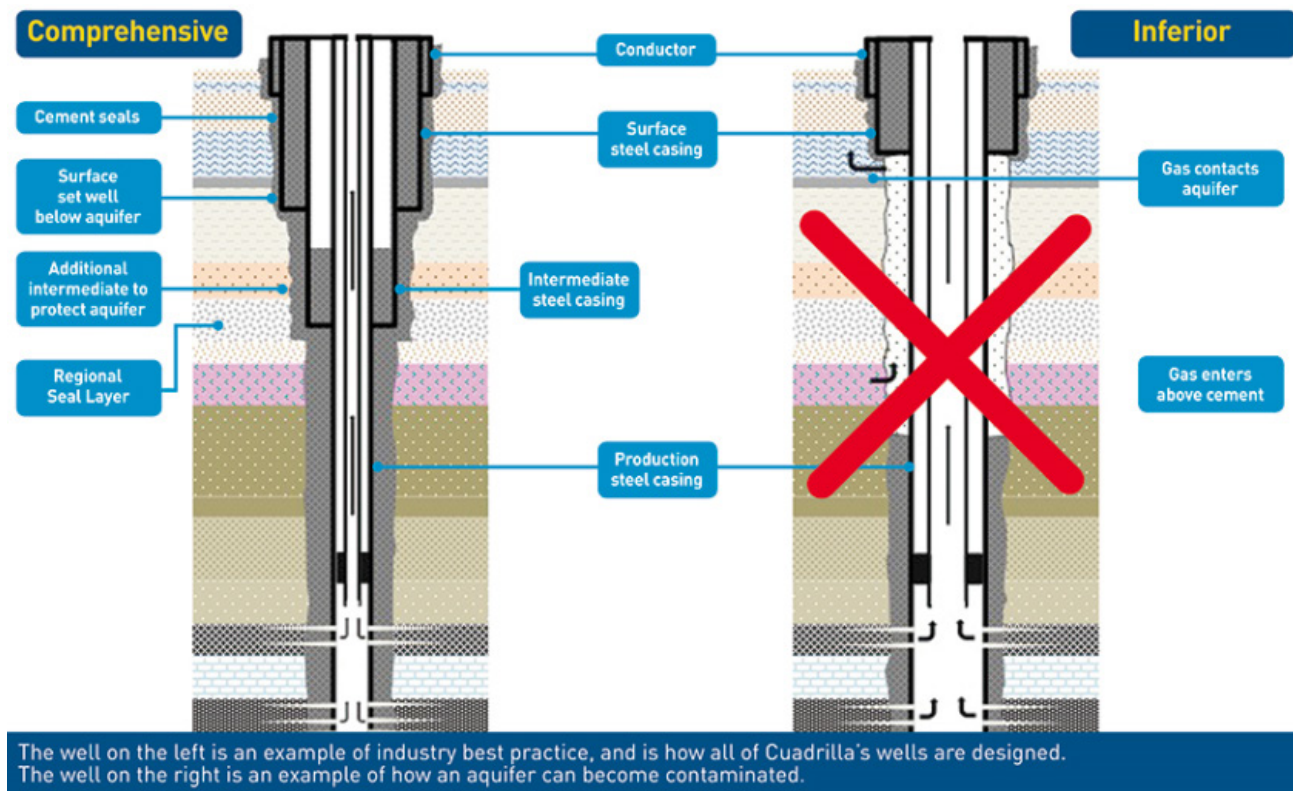

Figure 41. Contrasting older and newer vertical wellbore designs, courtesy of Cuadrilla: www.cuadrillaresources.com/protecting-our-environment/well-design/

The well construction on the left includes:

- A **conductor pipe** that typically will be 8-15 m deep for onshore wells, cemented around the exterior to allow drilling fluid circulation.
- A **surface casing** string that typically will be from 100 to 200 m deep, depending on regulations and local geological conditions, fully cemented to the surface.
- An **intermediate casing** string that may be required to control borehole instability or pressures, cemented to surface or well into the previous casing string (e.g. a minimum of 250 m into the previous casing).
- A **production casing** string cemented to surface or well within the previous casing string. The figure shows perforations in two productive zones to create access to the reservoirs.
- A **production tubing** hung and anchored within the production casing through which fluids are produced. There will usually be a pump attached to the bottom of the production tubing. In the case of dry gas wells (no co-produced fluids), the production tubing may be left off.

Well Construction

Drilling and Casing the Well

A finished oil or gas well has several casing sections that are cemented in place to the surrounding rock or to the previous casing section. Each casing section is assembled from many joints of steel pipe, and the total length of a casing section comprised of many joints is referred to as a “casing string”. The major casing strings that might be used in a vertical section of a Western Newfoundland energy well are discussed in more detail.

The first element in creating good wellbore integrity¹³⁷ is to make sure each casing joint (usually 10 m or 13 m long) is properly connected to the previous one so that no fluid leakage (such as gas seepage) can take place through the threaded connections. To this end, the casing strings are assembled by experienced crews with specialty equipment to provide the right make-up torque and avoid any cross-threaded connections. Regulatory guidelines may stipulate certain grades of casing and casing thread connection types for specific conditions, although in general, regulations are not so detailed. Instead, regulations tend to stipulate performance goals, as determined by measurements, such as a measurement of casing string pressure integrity before it is cemented into place. A properly assembled casing string has adequate pressure integrity for its entire length, and this integrity is tested to meet regulatory standards before well assembly is complete. If there is concern that integrity has been impaired during the service life, or if the nature of the service is changed, the casing is re-tested and certain types of cased-borehole geophysical logs may be run to identify leaks (e.g., cement bond logs, noise logs or other specialty logs) or to detect cement impairment behind the steel casing. For example, if a producing oil well is ever converted to an injection well, the production casing must be scanned with geophysical logging devices (cement bond log) to ensure zonal isolation.¹³⁸

¹³⁷ King G.E., King D.E. 2013. Environmental risk arising from well-construction failure—Differences between barrier and well failure, and estimates of failure frequency across common well types, locations, and well age. *Society of Petroleum Engineers Journal of Production & Operations* **28(4)**, 323-344. (SPE #166142-PA).

¹³⁸ Bellabarba, M. and nine other authors. 2003. Ensuring Zonal Isolation Beyond the Life of the Well. *Schlumberger Oilfield Review*, Vol 20, No 1, 18-31. Abbas, R. and nine other authors. 2002. Solutions for Long-Term Zonal Isolation. *Schlumberger Oilfield Review*, Vol 14, No 3, 16-29. (Note: Oilfield Review is published by a single company – Schlumberger – an oilfield service company – and is not independently refereed. Its articles are known as useful overviews with excellent graphics and explanations. They are recommended to those who want technical insight into oilfield upstream practices, yet do not want to cope with the details of accessing a number of fully refereed scientific papers. Free subscriptions and downloads of previous issues may be requested at www.slb.com/resources/publications/oilfield_review.aspx.)

Part of good practice is also making sure that cementing is carried out properly, discussed below.

The **conductor pipe** is a thin steel casing placed into a large diameter hole drilled to a depth of 8 to 15 m using a typical water-well drilling truck and a large auger. The conductor pipe is lowered into the open hole, and sacks of cement or concrete and gravel are manually placed to fill the gap between the steel and the soil so that drilling fluids cannot flow upward along the outside of the conductor pipe during drilling. This conductor pipe is then connected to the drill rig system so that as the surface casing hole is drilled, the drilling fluids are contained and circulated through the tanks so that the drilling fluid properties can be controlled.

To install the **surface casing**, a suitable diameter vertical hole, 12¾" (324 mm) is a typical size for onshore drilling, is drilled with a bentonite-water fluid (drilling "mud") to a depth below BGWP, or to a minimum depth stipulated by the regulatory agency such as 150 or 200 m. A strong steel casing, perhaps 10¾" (273 mm) diameter, is placed into the hole and cemented to the surface. When the cement has set adequately and the casing has been pressure tested appropriately, a flange is welded on to the casing, and a blow-out preventer and other sealing equipment attached for assurance of security and unimpeded fluid circulation. All elements bolted to the flange must meet rigorous standards and they must also be tested frequently so that deeper drilling and later operations such as well stimulation and production can be executed with minimal risk.

In Western Newfoundland, because essentially all of the groundwater being used by the local population is less than 100 m deep, mandating a specific depth such as 150 m or 200 m for the base of surface casing would seem to be appropriate minimum, but such stipulated depths must nonetheless be based on collection and analysis of adequate geological and hydrogeological data

An **intermediate casing** string may be required if there are unstable formations to be traversed during drilling, if there are numerous thin and uncommercial oil and gas zones in the rocks above the production zone that must be more carefully isolated, or if there are high formation pressures that could lead to drilling risks. In Western Newfoundland, although the rocks from the surface casing shoe to the potential targets at depth are competent (dense and strong) and pressures are moderate, it is likely that an intermediate casing string will be required in development wells. There may be exceptions to this in developing the shallowest part of the Green Point Formation, but with depths on the order of 3 km, with long horizontal sections, and if extended reach wells are used as shown in Figure 3 to access as much as possible of the off-shore region from land-based sites, it is almost certain that an intermediate casing strings will be incorporated. At this stage of exploration, it appears that there are few significant oil or gas zones in the region between 200 m depth and the top of the Green Point shale that would present significant risks to drilling, but this observation remains preliminary at this time and there may be local accumulations that have not yet been identified. The locations of such zones will have an influence on the design depth of the intermediate casing string.

Because the strata to be penetrated by drilling in this region have been significantly deformed and may be intensely naturally fractured, an intermediate casing string that is installed once a borehole has penetrated through the highly deformed zone (the "allochthonous" strata called Humber Arm, see Figure 9) may be necessary to continue stable drilling to the Green Point Formation target zone. Thus, the surface casing almost certainly has to be larger than 10¾" (273 mm) diameter to accommodate the additional concentric casing string. This means that the initial hole has to be drilled at a larger diameter from the beginning so that larger diameter casings can be installed.

Alternatively, rather than for borehole stability and pressure control, an intermediate casing string may be drilled specifically to just above the "kick-off" point where the vertical well starts to be deviated to horizontal, so that the horizontal section can be drilled with greater ease and without concern about uphole problems. In Figure 42, an explanation of the borehole strategy for the deep part of the Eagle Ford Formation play in southern Texas is

shown.¹³⁹ The target zone in this case is hundreds of meters lower than the Green Point strata, the geological age of the overlying strata are much younger and far less consolidated, and there is a greater likelihood of having thin gas-containing sands in the region from 2 to 4 km depth. In this case a deeper surface casing is used, on the order of 300-600 m, then an intermediate string to about 1500 m, another intermediate string to 3500 m, followed by the production casing which is subjected to perforating and HF to develop the target. One might suppose that in later development stages, once the drilling has been optimized, that it would be possible to eliminate one of the intermediate strings, especially if the surface casing string were installed quite deep.

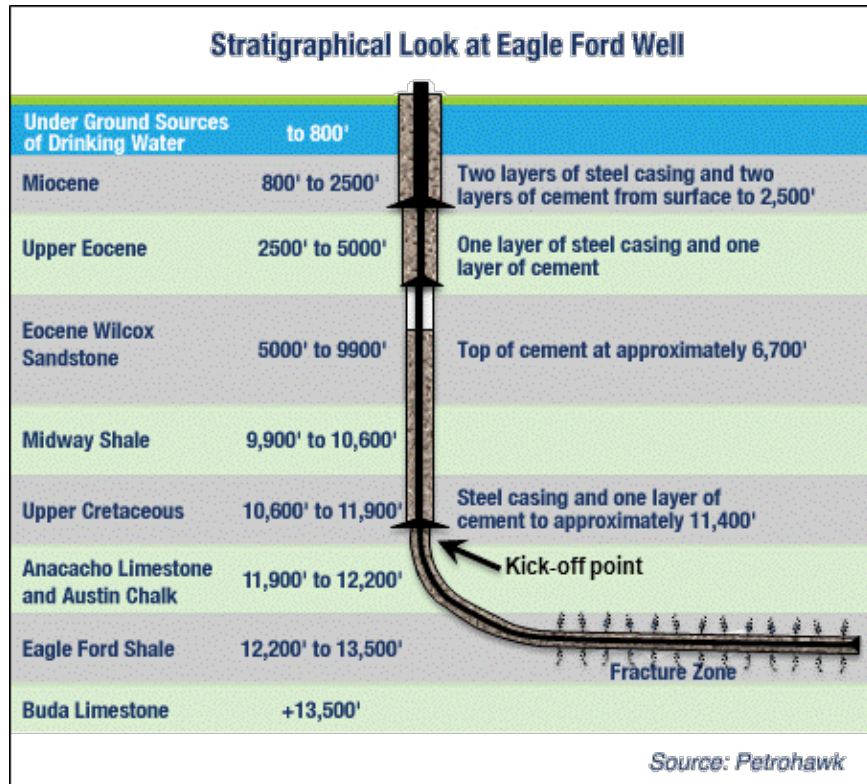

Figure 42. Eagle Ford completion strategy (modified from source, not to scale).

Modern practice is more-and-more to have a single intermediate casing string cemented all the way to surface with controlled quality cement. In some jurisdictions in the past, as shown on the right hand side of Figure 41 and in Figure 42 above, cementing only partway up the exterior of the casing was permitted. Because an uncemented portion has been found to be associated with more frequent incidents of gas migration, the evolution of regulations has been toward more complete cemented columns. In any case, a possible developer of the Green Point shale would design a well plan and then discuss it and justify it with the regulatory body. The ability to drill much more quickly than even 10 years ago means that as a new region develops into a play, the companies involve find ways to reduce hole costs through better drilling practices, potential elimination of one casing string, and even more rapid hydraulic fracturing methods

¹³⁹ The company that produced this graphic, Petrohawk, was acquired in 2011 by BHP Billiton. Of particular interest is that the Eagle Ford play was pioneered by Petrohawk, a small company with flat management. Virtually all of the shale oil and shale gas plays in the United States and Canada were initiated by small and medium sized companies, and the large multinational companies entered only once the play became clear and somewhat "derisked". It is widely acknowledged that the presence of many small and intermediate companies in North America has fostered risk-taking and rapid innovation. In contrast, Europe has few such companies and a heavier regulatory hand, so rapid development and risk-taking in Europe is widely viewed as being virtually impossible.

The **production casing** is the final cemented casing string placed in the bore hole. For shallow wells less than 2 km deep, the borehole may be drilled in its entirety from beneath the surface casing to the kick-off point where the well is gradually turned to horizontal. The full horizontal section is drilled in one run if borehole stability is adequate, but it is not yet known what is achievable in the Green Point Formation because of the complex subsurface conditions and highly deformed strata in the upper section. In many jurisdictions there are few drilling problems and wells are vertical and relatively shallow, as in the vertical gas and oil wells that were used to develop fields in east central Alberta, generally less than 2000 m deep. In such cases, if there is no intermediate casing, the production casing is cemented all the way to the surface.

Because the horizontal section to be drilled requires considerable care, it is more common in shale oil development to adopt a strategy such as shown in Figure 42, where the beginning of the "kick-off" is the bottom of the intermediate casing, and curved portion of the well and the horizontal section are drilled, and then the production casing installed and cemented to the toe of the well. Then, to access the formation, it is necessary to perforate the steel casing and hydraulically fracture the section, and this is still perhaps the most common approach for the MSHF technology known as "plug-and-perf". Figure 14 shows the plug-and-perf approach with packers and fractured intervals.

An alternative approach is to drill and install the production casing to the beginning of the horizontal section, as shown in Figure 40. Once the cement is set, the horizontal section of the borehole is drilled in its entirety, the drill string withdrawn, and a special assembly consisting of special swelling packers and sliding sleeves is installed and fastened with an anchor to the interior of the bottom part of the production casing. The swelling packers expand over the course of several days, isolating the horizontal wellbore at many points, and then stimulated by HF. This approach is becoming more common for the MSHF technology known as the "ball-drop" method.

In all cases, the production casing is cemented from the shoe, either all the way to surface or well into the previous intermediate casing string, so that a seal is ensured. The high alkalinity of the cement used in the oil industry also protects the steel casing from deterioration if there are acidic fluids in the formation such as carbon dioxide (CO₂) or hydrogen sulphide (H₂S) acid gases dissolved in water.

Cementing Practices

Well cementing requirements and integrity testing are covered in part by mandated regulations. The goal is to achieve a continuous, effective seal between the casing and the rock mass, or between the current casing and the previous casing, so that the wellbore has full pressure integrity along its length for its active life for the range of conditions it will experience¹⁴⁰ (also see previous footnotes). If this integrity is initially inadequate, after the hole is completed, or if it is breached any time during active well life, the operator must fix the problem immediately. Casing integrity testing is performed during production if there is concern about issues such as thread leakage development, casing rupture, corrosion, or wear. With modern cementing practices and quality control, having to immediately repair a new well is rare, but during operations, impairment may take place. Because the production casing is not exposed to mechanical wear with downhole electrical pumps, wellbore integrity for a shale oil well is seldom an issue after the well is completed. Nevertheless, as discussed later, behind-the-casing gas migration continues to be an issue for a small percentage of energy wells.

As each casing string is assembled and lowered down the borehole with the joints properly threaded together with thread sealant, centralizers and scratchers are attached to the exterior of the steel casing (Figure 43). The current tendency in the industry is to increase the number of centralizers and scratchers to assure a better seal for the region between the casing and the rock mass. Regulatory guidelines are not so proscriptive as to specify the

¹⁴⁰Dusseault, M.B., Jackson, R.E. and MacDonald, D. 2014. Towards a Road Map for Mitigating the Rates and Occurrences of Long-Term Wellbore Leakage. 69 pages. Report funded by a grant provided by the Alberta Department of Energy, available from the author or at www.geofirma.com/

number of centralizers or scratchers; rather, the guidelines require a specific level of performance. Because attaching centralizers and scratchers takes some extra time during installation of a casing string,

There is considerable merit in "...getting it right the first time..." with a high-quality casing and cementation, as this apparently greatly reduces the chances of wellbore integrity impairment later in the life of the well.¹⁴¹ The article by King and King (2013) referred to in a previous footnote is worthy of review, but there is some concern that that article does not address all of the critical mechanisms; nonetheless, it is one of the best compendiums available in the literature.

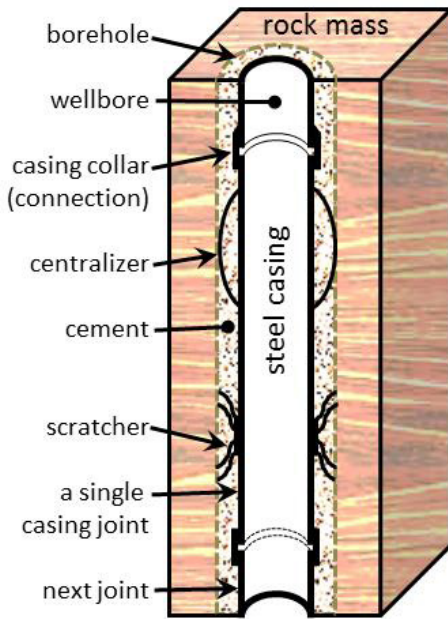

Figure 43. Casing-cement-rock system, with centralizers and scratchers.

Centralizers are springs designed to keep the casing in the center of the hole so that the drilling fluid is adequately displaced and the cement slurry can completely surround the casing to set and form an integral sheath. Before the cement slurry is pumped, the casing string is lifted up and down 25-35 m (reciprocated) and rotated while fluids are circulated to clean the borehole wall and flush out residual drilling fluids. Scratchers help remove drilling mud caked on to the borehole wall, and often special chemical solutions precede the cement placement to help disperse and dislodge this drilling fluid mud cake so that the cement can make direct contact with the rock formation. If there is a cake of drilling fluid solids left on the side of the hole that is not removed, this material can shrink in reaction with the alkaline cement and this could result in a thin channel (less than a millimeter in width) behind the casing that could serve as a conduit for fluids. This issue becomes of greater concern if there are extensive borehole breakouts and hole enlargement that developed during drilling, as it becomes impossible to dislodge all of the drilling fluid cake in such cases, so there is a greater probability of having well integrity problems in the future.

To place the cement behind the casing, a rubber plug is placed inside the casing, then cement slurry is placed on top of the rubber plug as it is pumped to the bottom of the casing (the shoe), and this wiping action cleans the drilling fluid off the inside of the casing and keeps the downward moving cement from mixing with the fluid in the casing. Once the plug hits the shoe at the bottom of the casing, it opens, and the cement slurry flows out of the shoe and up and around the casing. The casing is perhaps rotated and reciprocated during this displacement process to try and ensure a good

¹⁴¹Rigorous statistics for some of these statements, such as the widely-held view that current well completions are better quality than a decade or several decades ago, are not available in Canada, but are generally held to be true, based on various conference article and discussions among professionals working in these areas. Old legacy wells leak more frequently than newer wells, but there are also geographical differences, depth differences, and so on, that make it challenging to be quantitative.

contact of the cement with the formation all around the borehole wall. Once the appropriate volume of cement is mixed, a second wiper plug is placed in the casing to displace all of the cement into the exterior annulus while wiping the inside of the casing clean of cement. The amount of cement that is mixed and pumped down the hole is calculated from borehole shape information garnered from borehole geophysical logs that were run in the hole before the casing was placed.

Because once the trailing plug has been sent down the interior of the casing it is impossible to mix and inject more cement to rise around the casing, it may be necessary to correct some problems, should they occur. For example, suppose that for some reason the cement did not reach the surface, as required by the well permit, either because of a miscalculation or some lost cement (cement is dense – 2.05-2.10 g/cm³ ideally, and can fracture into formations where the lateral stresses are low). A temperature log will be run inside the casing to determine the height of the cement behind the casing. Then, an attempt will be made to snake down a thin steel string in the uncemented annulus to try and continue the cementing process.

Other measures can be required to achieve a more complete seal around the casing and many products are promoted as good sealants.¹⁴² This may involve special additives to the cement to increase density or facilitate placement (e.g. latex, retardants, super-plasticizers, etc.), creating a light-weight cement (with hollow glass spherules, vermiculite, foaming agents) in cases where it is necessary to use a cement of lower density to avoid lost circulation, creating a cement more resistant to thermal deterioration by using finely ground silica, and so on. However, in some cases these products have not been independently tested by third parties under real conditions to verify claims, and there has not been a compendium of publicly available data collected from case histories in the field on which to base assessments. In areas where claims remain dubious or at least unsubstantiated, additional research activity in a field mode is probably warranted.

Once the cement is placed around the casing, it is allowed to set for a stipulated time period, the cased hole is examined to look at the quality of the cement behind the casing, tested to insure it is capable of withstanding the pressures which might, in extreme circumstances, be expected, and then drilling proceeds or the well is completed. Particularly if it is the production casing that was just installed, the cased well is logged with special tools called “cement bond logs” that use high-frequency acoustic waves to help assess the condition of the cement behind the steel casing (see footnote 138, 139 for example) to assure that a good cement-rock seal has been achieved. Pressure testing of the casing involves filling the casing with water and raising the pressure while measuring if there any losses of water or pressure losses. Pressure testing of the casing and cement bond logs can be repeated at any time during the well life if concerns exist as to the integrity of the well.

Well cement is placed as water-based Portland cement slurry; the great majority of energy wells in Canada use Class “G” Oilfield cement and a target slurry density of about 2.05 g/cm³. In some applications, as mentioned above, additives may be used to improve the performance properties of the cement (those properties needed to achieve the goal of sealing the well under the service conditions it will encounter). Replacing 70-75% of the cement with silica flour (finely ground quartz – SiO₂) is required in thermal wells (steam injection wells in viscous oil development) to create cement that is stronger and more resistant to thermal dehydration. Special cement formulations are used in the presence of salt beds to avoid dehydration and shrinkage. Latex-based additives are said to lower the permeability of the cement and give it more ductility (the ability to deform without losing sealing characteristics), and certain types of cement are said to be “self-healing” in the sense that if small cracks develop, these are blocked (sealed) by products in the set cement. In cases where natural gas entering the fluid cement during the emplacement process is a concern, chemicals are added to scavenge the gas and suppress the development of gas channels. Foamed cements or cements that have additives that produce gas are intended to counteract the natural tendency of neat

¹⁴² To get an idea of the wide range of additives, visit websites of the companies that offer well cementing services, with names such as Schlumberger, Halliburton, Trican, BJ, and so). Also, the website PetroWiki has good industry information: petrowiki.org/Cement_slurry_design#Categories_of_additives (and for many other industry topics as well)

cement slurries to shrink a small amount when setting. Use of additives is typically not mandated or controlled by the regulatory agency; it is the responsibility of the owner of the well to assure that appropriate cement formulations and additives are used in the conditions encountered so that the energy well is properly sealed, ready for service, and resistant to impairment.

The best guarantee against future leaky well problems is a high quality initial well installation (primary cementation), so attention should be paid to well casing and cementing. Although well cementing does not have to take place under direct supervision of a professional engineer at this time in Canadian jurisdictions, it is important to verify that the appropriate materials and procedures are used and that the installed well meets mandated performance criteria (pressure tests, bond log quality). In this way, future issues relating to well integrity and risks of interaction with shallow aquifers will be minimized. In the Green Point shale region around Port au Port Bay, there appear to be no exceptional conditions such as very unstable shales, high pressures, numerous gas zones, or serious lost-circulation¹⁴³ zones that would impede installation of high quality cement-sealed casings. Nevertheless, as in any complex industrial activity, there will always be some cases where sealing of all leakage pathways for the entire life of the well, including the post-decommissioning period, is not achieved. Quality control and assurance, good quality materials and placement, and good surveillance are needed to achieve good performance; regulatory guidelines and enforcement are needed to ensure the process. There may be improvements in outcomes if the cementation processes during well emplacement are overseen by a third-party licensed professional with experience.

In any case, realistic concerns exist about the quality of cementation and the sealing characteristics of cemented energy wells. Assuming that the cementing operation was carried out correctly, some of these concerns include:

- In the curved part of the wellbore from the “kick-off” point (Figure 42) to where the well becomes horizontal, it is difficult to centralize casing, and this can lead to unequal cement thicknesses and incomplete cementing around the entire steel casing in this interval.
- Cement tends to shrink during and after setting, and this shrinkage can lead to the development of microannular (very thin aperture) fractures behind the casing, generally circumferential fractures between the cement and the rock.¹⁴⁴ If the placement density of the cement is low, this problem is exacerbated.
- If the production casing is subjected to the many pressure cycles of a MSHF completion, the cement can develop radial microfractures as well as circumferential microannular fractures.
- In some conditions, high permeability strata can lead to water loss from the cement while it is in a fluid state, giving problems in the achieving of a high-quality cement sheath condition.
- During production, when the fluid pressure in the production casing is drawn down to very low levels, the internal pressure on the casing is at its lowest, and this can cause the microannular (circumferential) fractures to have a larger aperture, allowing a continuous gas column to develop (a vertically buoyant bubble)¹⁴⁵, making slow gas seepage more likely.

¹⁴³ A lost-circulation zone is a bed of extremely high permeability through which the drilling fluid can escape without forming a seal. Usually, such zones are associated with limestones and dolomites that have been locally dissolved, leaving large cavities and channels, or intensely fractured rocks with wide-open fractures.

¹⁴⁴ Oyarhossein M., Dusseault M.B. 2015. Wellbore Stress Changes and Microannulus Development Because of Cement Shrinkage. Proceedings 47th American Rock Mechanics Symposium, San Francisco, Paper ARMA 15-118, (available on OnePetro™), 9 p

¹⁴⁵ Jackson R.E., Dusseault M.B. 2014. Gas Release Mechanisms from Energy Wellbores. Proc. 48th American Rock Mechanics Association Symposium, Minneapolis, Paper ARMA 14-7753 (available on OnePetro™), 5 p

Inadequate cementation is a problem that leads to perhaps 5% of energy wells leaking slowly.¹⁴⁶ It can be greatly reduced through better quality control, better materials, and better surveillance of cementing operations by a licenced professional.

Well Completion

Once a wellbore has been drilled, cased and cemented, it is necessary to “complete” the well, linking it to the rock mass so that oil or gas can flow at a rate that is commercially viable. Pathways must be created between the wellbore and the rock mass at many locations (stages) along the horizontal well so that a large rock volume of rock is accessed, and many previous figures in the report showed elements of this process. Typically, from 15 to 40 “stages” will be fractured along the horizontal well length for shale gas and shale oil development, spaced as closely as 30-40 m in some low-permeability fields and particularly in cases of thinner zones in shale oil plays, and as much as 120-150 m apart in other formations of higher permeability that are thicker, and particularly in shale gas plays.

There are several different methods to access the rock mass, of which the two most common are described here. Well completion generally has no effect on well integrity in the long term or the short term, as all the activity is taking place at the bottom of the well, and the critical part of the wellbore where good seals are needed and casing must be intact is the section from the producing formation to the surface. Later in this discussion paper, the possibility of interwell communication during hydraulic fracturing is discussed, as this involves a potential impairment of wellbore integrity.

Different approaches are available to provide access from the wellbore to the formation, and these approaches are implemented only in the productive horizon. The productive horizon in a vertical well case can be quite thick (several hundred meters vertically upward from the bottom of the wellbore), and in vertical wells there is almost always fully cemented production casing from the surface to the bottom of the borehole. Geophysical logs combined with geological modeling, core and cuttings examination, and HF mathematical simulations are used to decide where to place perforations and carry out HF stimulation.

In the approach shown in Figure 14, the production casing is installed to the toe of the well and cemented. To pierce it, perforating devices in a linear array about 3-4 m long are sequentially placed at each location and detonated to create a set of 30 to 60 holes 15 to 20 mm in diameter over the length of 3-4 m. Then, another section is perforated, and so on until all the locations for well stimulation are finished. Now, injection tubing¹⁴⁷ with a double packer system is lowered into the wellbore, and the packers are expanded against the inside of the casing to isolate one or several of the perforated zones. These perforations now become the channels through which hydraulic fracturing is carried out. Note that the production casing is protected against any issues that might arise from repeated high pressure flexing of the cemented casing if injection tubing is used. If HF is repeatedly carried out with massive pressurization of the production casing itself (i.e. without injection tubing), the integrity of the seal between the production casing and the rock mass between the surface casing shoe and the productive horizon can be impaired through the formation of a very narrow microannular space.

Once hydraulic fracturing is carried out successfully at one site along the horizontal wellbore, the packers are released, moved to isolate another section of the horizontal well, and the hydraulic fracture well stimulation process is repeated. There may be various flow tests done during or after the process for evaluation, and the procedure can allow for flow-

¹⁴⁶ Slow leaking means on the order of 200-400 gm of methane per day, enough to give small but steady bubbling around the exterior casing if the ground is water saturated, but not enough to sustain a flame, for example. The figure of 5% is highly conjectural, and more research work is needed to quantify such estimates, which range from less than a few percent to as much as 20%, depending on region and geology.

¹⁴⁷ The word “tubing” describes a string of pipe that is suspended in the hole without cement (e.g. production tubing), or that is introduced into the hole for a special purpose, such as perforating or fracturing. Once operations cease, tubing is removed from the well. Tubing protects the integrity of the production casing.

back fluids to return to the surface immediately after each fracturing period. Once the well is completed, the injection tubing is removed, production tubing is installed if required, and the well placed on production.

A recent and more-and-more adopted new method for completing an unconventional oil and gas well is the sliding sleeve and drop-ball method (Figure 44 – www.packersplus.com/). This method was developed in Alberta and usually makes completing a well easier and quicker.



Figure 44. The ball drop and sliding sleeve method of completing a horizontal well.

The horizontal section is left as an open drill hole (no cement beyond the shoe of the production casing shown in Figure 40) but a special assembly with fluid ports, sliding sleeves, and hydrophilic expanding packers is installed, anchored to the inside of the production casing and attached to a tubing string. To access the formation, after the packers have swelled because of the contact with water, a small ball is dropped to seal an internal seat, pressure is increased on the sealed seat to slide a sleeve towards the toe of the horizontal section to open the ports accessing the formation, and hydraulic fracturing is carried out. For the next stage, a slightly larger ball is dropped to seal the next internal seat, and pressure is used to open the next sleeve, and so on. The balls dissolve slowly in water and the resulting debris is flushed out so the wellbore can produce freely.

Well Integrity During Production

Production of gas or oil may take place directly into the production casing, but for all shale oil wells, installing a pump is needed to sustain oil lifting capability, and common practice is to install a pump on the bottom of the production tubing string, which in turn is anchored to the production casing. The pump may be mechanical (the classic “donkey”) or electric submersible. All the fluids being produced (gas or oil, plus formation water in most cases) pass through the pump, and through this production tubing out of the wellhead to be processed. This means that the annulus between the production tubing and the production casing is inactive, and can therefore be monitored for any pressure changes that might indicate a loss of pressure integrity in the tubing or the casing during the production life, which may extend to two or three decades for shale oil wells, perhaps longer if new technologies are developed in the future to stimulate more oil recovery. Monitoring the pressure in this annulus is standard practice, and is a great aid in avoiding serious leaks and wellbore problems.

Gas Migration during Production

With some technologies and in some geological environments, maintaining wellbore integrity is challenging because of severe demands placed on the casing-cement system. For example, this occurs in thermal wells for heavy oil production in Alberta, where steam at temperatures as high as 325°C may be injected through the production/injection tubing. Not only does this cause thermal expansion and contraction over the injection/production cycles, the high temperatures accelerate electrochemical corrosion of the steel casing and can dehydrate shales around the wellbore, leading to a loss of wellbore integrity through the opening of a pathway outside the casing and cement. Other reasons for casing integrity loss include large-scale reservoir compaction and casing rupture, or the triggering

of formation shear between the reservoir and the overlying rock as the result of large changes in pressure.¹⁴⁸

There is a low likelihood of casing integrity loss in the Port au Port Bay area from the reasons in the previous paragraph because the formations are low porosity and therefore resistant to shearing, the temperature effects that would be imposed upon the wellbore are minor, and the volume changes associated with the depletion of a shale oil reservoir are very small compared to a conventional oil reservoir in a porous sandstone (usually 10-20% porosity) because the shale oil reservoir rock is stiff. All these factors, plus the fact that the pressure in the productive horizon is being lowered because of continued depletion, mean that maintaining well integrity would be relatively straightforward during exploitation of the Green Point shale, providing the casing were properly sealed during primary cementation. Also, any well integrity problems that arise outside of the casing will most likely be associated with seepage of gas, not oil or saline water, because free gas is buoyant (saline water is not buoyant whatsoever).

If loss of casing integrity is observed at any time during production or while the well is inactive but not decommissioned, the operator must fix the problem under the requirements of the regulatory agency. This involves identifying the location and nature of the leakage problem, implementing a suitable method to stem the leak such as perforating and pressure-squeezing a sealant into the region behind the casing ("perf-and-squeeze"), followed probably by placement of an expanding steel sleeve (a casing patch) to restore the pressure integrity of the production casing.

During production, the annulus between the surface casing and the production casing is monitored for gas flow (called SCVF – Surface Casing Vent Flow). There is often a small amount of gas escaping from this annulus, and often much of the SCVF gas is coming from intermediate depth zones – thin gassy zones that are not commercially exploitable, or even from organic matter deterioration at depths as shallow as a few hundred meters – called biogenic gas. There are regulatory guidelines for how much SCVF is permitted during production in Alberta (for example), and it is important not to allow this gas pressure to build up, as this would promote the forcing of the gas outside of the surface casing shoe, where it can migrate toward lower-pressure regions such as shallow aquifers and the surface.¹⁴⁹ It is most likely that any drillhole in the Port au Port Bay area would encounter some strata that are gassy in the sedimentary section above the Green Point Formation, within the Humber Arm deformed group of rocks that overlie the less deformed underlying strata. The gas will be thermogenic in nature, not biogenic. There is no evidence that such gassy strata are overpressured, although such data are not exhaustive and this would be verified during the early phases of any protracted exploration activity.

There is a virtual certainty that shale oil production wells will be re-entered several times during their life span in order to do some stimulation of production (re-fracturing or limited volume acid treatment to clean near-wellbore formation damage), changing the pump, or some other form of stimulating the near-well environment to promote improved liquid flow. In the extreme, a new horizontal section could be drilled from the existing cased wellbore, but more likely the previously fractured horizontal section will be partially or entirely re-fractured several times during a 20-30 year well life to rejuvenate old pathways or open new pathways for oil or gas to flow to the wellbore. It is common practice before restimulation (or it could be mandated) to run another cement bond log to give some assurance that the behind-the-casing pathway has remained sealed.

Leakage Behind the Casing

It appears that the major wellbore integrity issue in the unconventional oil and gas industry is related to gas migration outside of the production casing, up around the surface casing shoe, and interacting with shallow GW or venting

¹⁴⁸ Dusseault M.B., Bruno M.S., Barrera, J. 2001. Casing shear: causes, cases, cures. *Society of Petroleum Engineers Drilling & Completion Journal* **16(2)**, 98-107

¹⁴⁹ Harrison S.S. 1985, Contamination of aquifers by overpressuring the annulus of oil and gas wells: *Ground Water*, **23(3)**, 317-324.

to the surface.^{150,151} This pathway, as well as other subsurface pathways shown in Figure 45, is common to all oil and gas wells¹⁵², and is now discussed in more detail. Although stray gas has been studied in the literature¹⁵³, there is little quantitative information about the behind-the-casing pathway (how often it develops, magnitude of gas seepage, etc.). This suggests that baseline assessment of groundwater and natural methane occurrences would be an important activity in areas that may experience oil and gas development. Surface casing vent flow data must be registered with the regulatory agency; for example, the AER keeps records of all occurrences, therefore there are excellent statistics available in this area. There are, in contrast, few data on gas migration behind casing, insufficient to draw strong quantitative conclusions, although there is a great deal of indirect evidence that gas leaking into groundwater wells is not a major public health issue.¹⁵⁴

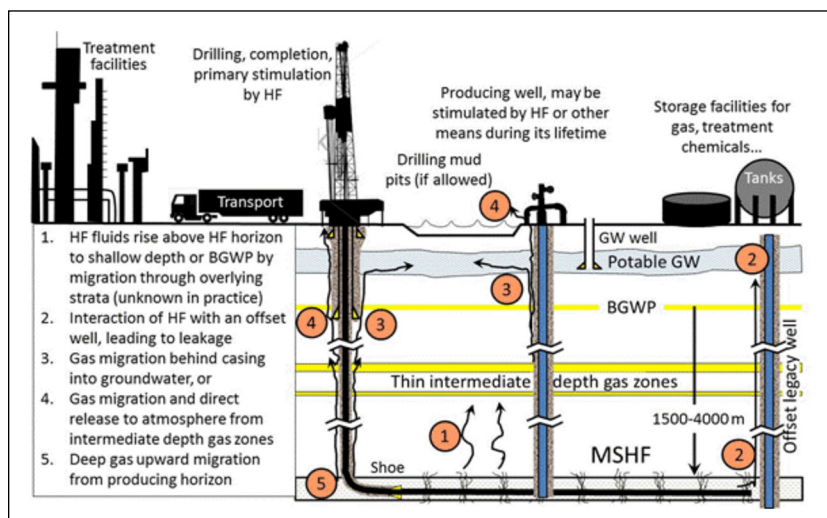

Figure 45. Potential subsurface GW contamination pathways.

One approach to a better understanding of methane in groundwater wells is to sample the wells being used as sources of water for consumption. However, because many water wells are improperly sealed and the wells may access multiple zones or only one non-defined or ill-defined zone, such data cannot be considered to be scientific baseline data for a regional study, although it serves as a baseline for that well. An example of a recent survey of domestic wells above an American oilfield (Wattenburg, CO) that has been active since 1970 and has more than 19,000 producing wells and more than 7500 decommissioned wells was published in early 2014.¹⁵⁵ The study found that in a sample of 223 domestic GW wells, a number of which were resampled over a period of five years, 78% had dissolved methane, and some had free methane. The occurrence of methane did not correlate with proximity to energy wells, and the methane was found to be more than 98% of biogenic (shallow) origin, therefore not from thermogenic sources (deep, from the intermediate or producing zone). Even for the few cases where the gas was of thermogenic origin, the specific pathway (natural or man-induced) could not be deduced. Similarly Siegel et al. 2015 (footnote 65) found no

¹⁵⁰ Watson T., Bachu S. 2009, Evaluation of the potential for gas and CO₂ leakage along wellbores: *SPE Drilling & Completion* **24(1)**, 115-126. SPE #106817.

¹⁵¹ Dusseault M.B., Gray M.N., Nawrocki P. 2000. Why oilwells leak: Cement behaviour and long-term consequences. *Proceedings Society of Petroleum Engineers Int. Oil and Gas Exhibition, Beijing*. SPE #64733.

¹⁵² Dusseault M.B., Jackson R. 2014. Seepage pathway assessment for natural gas to shallow groundwater during well stimulation, in production, and after abandonment. *Environmental Geosciences* **21(3)**, 107-126.

¹⁵³ Gorody A.W. 2012. Factors affecting the variability of stray gas concentration and composition in groundwater: *Environmental Geosciences* **19(1)**, 17-31.

¹⁵⁴ Natural gas is not toxic in any way, but if it enters an aquifer, it can sour the water, making it unpalatable. Gas seeping into basements and confined spaces from energy wells is an exceedingly rare event, therefore the risk of explosions from such a pathway is vanishingly small (methane is very buoyant in air, and tends to easily escape).

¹⁵⁵ Li, Huishu, Carlson, K.H. 2014. Distribution and Origin of Groundwater Methane in the Wattenburg Oil and Gas Field of Northern Colorado. *ACS Journal of Environmental Science and Technology* **48**, 1484-1491.

relation between methane occurrence and energy wells in a large shale gas development area in Pennsylvania.

In contrast, some work has shown that methane found in domestic GW wells in certain areas in Pennsylvania is somewhat correlated to the distance from recent energy wells drilled in the 5-6 year period before the study was done.¹⁵⁶ Specifically, in the limited number of wells in this study, it appeared that methane occurrences in groundwater wells are statistically more common nearer to energy wells. These different results may reflect geological differences, as the strata in Colorado are quite different from the strata in Pennsylvania, and there are different protocols for sampling, and water wells are very poor as “scientific instruments”. The results are reminders that vigilance is needed, baseline data should be established (too late in many oil and gas areas), and careful scientific analysis performed before wide-sweeping conclusions about well integrity, groundwater contamination and gas migration pathways can be drawn. Furthermore, there is an inherent danger in taking the well-documented cases in the USA as suitable analogues for Canadian plays, as the regulatory environment and the resource ownership position in the two countries are radically different. It also deserves mention that thermogenic gas in shallow wells is commonplace. In the St Lawrence Lowlands, for example, many wells have either shallow biogenic methane, but also deep thermogenic methane coming from the gases in the deep Paleozoic strata (Utica, Lorraine Formations). This is not unusual; thermogenic gas in domestic water wells above deep gas zones in sedimentary basins is common throughout the world,¹⁵⁷ which also suggests that in any new area to be developed for oil or gas, a carefully designed survey of natural gas occurrence and origin should be executed.¹⁵⁸

Clearly, potential pathways should be understood and assessed in order to develop rational regulatory guidelines and to execute safe and reliable well installation and management practices.

Pathway 1 in Figure 45 has triggered much concern among opponents of unconventional oil and gas development. However, there is apparently no known case of fracturing liquids or gas migration from the shale oil or shale gas target horizon directly up through the rock mass to the surface or into shallow aquifers during or after well stimulation. Reasons for this were discussed previously in the section on hydraulic fracturing. Nonetheless, the persistence of claims in the grey literature and in the public perception is evidence of a profound mistrust of technology and large companies who appear to be non-transparent, deceptive, or patronizing.

Pathway 2 in Figure 45, fluid migration up an offset well during hydraulic fracturing, has happened at least once in practice in Canada.¹⁵⁹ In 2012, injected fluids rose to the surface in an offset legacy well producing from the same formation during active fracturing of a horizontal well north of Calgary, AB. This incident caused the Alberta Energy Regulator to publish a detailed study¹⁶⁰ of the event and led to the issuance of new guidelines to reduce the probability of such an incident in the future.¹⁶¹ In Alberta alone, over 450,000 oil and gas wells have been drilled, and approximately 175,000 of these wells have been subjected to hydraulic fracturing operations to date, so the presence of nearby active or legacy wells must be considered during planning for drilling and well stimulation in order to preserve the integrity of the offset wells. By contrast, in Western Newfoundland Port au Port area, legacy wells penetrating to the depth of the Green Point Formation target horizon are uncommon (only a few in the immediate area), their locations

¹⁵⁶ Jackson R.B. and eight other authors. 2013. Increased stray gas abundance in a subset of drinking water wells near Marcellus shale gas extraction. *Proceedings of the National Academy of Sciences, U.S.A.* **110(28)**, 11250-11255.

¹⁵⁷ Kappel W.M., Nystrom E.A. 2012. Dissolved Methane in New York Groundwater. *United States Geological Survey Open File Report 2012-1162*. 6 p (available from the USGS website www.usgs.gov/)

¹⁵⁸ Lan X., Talbot R., Laine P., Torres A. 2015. Characterizing Fugitive Methane Emissions in the Barnett Shale Area Using a Mobile Laboratory. *Environmental Science and Technology* **49**, 8139-8146.

¹⁵⁹ Fluid migration is not the same as a detectable pressure pulse. High pressure fracturing operations can create a pressure response some distance away, certainly hundreds of meters in some cases, but because water is relatively incompressible, a pressure response can be detected at great distance, and is not proof that a breaching of a barrier has taken place.

¹⁶⁰ www.aer.ca/about-aer/media-centre/news-releases/news-release-2012-12-12-nr2012-12

¹⁶¹ AER, 2013, Directive 083: *Hydraulic Fracturing – Subsurface Integrity*: May 21 2013, 15 pages, The Alberta Energy Regulator, Calgary, Alberta, Canada, www.aer.ca/documents/directives/Directive083.pdf

are well known, and their histories are available. This pathway is therefore not an issue in the Port au Port Bay area.

Pathways 3 and 4 in Figure 45 are the pathways of greatest concern, especially after well decommissioning when the inside-the-casing pathway has been plugged with several long cement plugs and mechanical packer seals. Because of cement placement issues and cement shrinkage¹⁶², gas influx from intermediate-depth gas zones can lead to the development of gas columns behind the external casing, and the buoyancy of the long gas column can lead to slow seepage, either into shallow aquifers or to the surface where methane enters the atmosphere. The seepage rates are generally slow because the aperture (width) of the pathways is small, far less than a millimeter, a conclusion based upon cement bond logs, laboratory tests, and other sources. Also, the source of the methane may not be a zone of high permeability; rather, it is likely a limited thickness zone of tight rock, otherwise it would be a target for exploitation.

General methane emissions including all fugitive gas sources from natural gas development have recently been studied¹⁶³, but there exist few systematic regional studies of gas migration from energy wells in Canada or elsewhere. Such studies have been recommended (see previous footnotes), and would serve as an excellent guide to development of regulatory requirements to reduce the incidence and rate of gas migration. In Western Newfoundland there are likely few intermediate-depth gas-bearing zones, so these two pathways are expected to be far less frequent and problematic compared to some other jurisdictions such as eastern Alberta and western Saskatchewan where there may be a half-dozen thin gas sands at depths of 200 to 1000 m (i.e. below the surface casing shoe but above the producing zone).¹⁶⁴ In the Alberta case, these thin gas sands can be less than a metre thick, but they are regionally continuous over substantial areas, as they are encountered in all wells in a small field, for example.

Pathway 5 in Figure 45 comprises leakage of target formation gas upward along the outside of the casing toward the surface. The Green Point Formation is a shale oil play, but there is much methane dissolved in the oil. In fact, as the pressure in the oil is dropped during production, some of the gas comes out of solution once the pressure drops below the “bubble point” (the equilibrated natural saturation pressure).

Cases where the deep target gas is found to seep up slowly along casings seem to be associated exclusively with poor primary cementation of wells, or in wellbores that were subjected to severe conditions during service. Because a reservoir is depleted by production, the fluid pressure in the target horizon is reduced over time to much lower values than in the fluids above the reservoir. This inhibits gas migration and acts against the development of a continuous buoyant gas column behind the casing having its origin in the producing formation.

In addition, the lower 500 m of a 1000–3500 m deep casing string is likely to be well-sealed because of the high static pressure that is generated in the column of liquid cement during primary cementation of the production casing. This high pressure actually helps densify the cement through filtration, reducing cement issues and improving the seal between the rock and cement. Pathway 5 would be of limited concern in the Port au Port Bay area, providing that good quality assurance of the primary cementing operation is maintained

This leaves only Pathways 3 and 4 as significant concerns, and indeed there is good evidence that a significant percentage (from a few % to as many as 10%)¹⁶⁵ of oil and gas wellbores in some areas experience gas migration. It

¹⁶² Reddy B.R., Xu Y., Ravi K., Gray D., Patillo P.D. 2009. Cement shrinkage measurement in oil-well cementing – a comparative study of laboratory methods and procedures: *Society of Petroleum Engineers Journal of Drilling & Completion* **24(1)**, 104-114 (SPE #103610-PA).

¹⁶³ Pétron G., and 29 others. 2012. Hydrocarbon emissions characterization in the Colorado Front Range – A pilot study. *Journal Geophysical Research, Atmospheres* **117(D4)**, D04304, doi:10.1029/2011JD016360.

¹⁶⁴ Erno B., Schmitz R. 1996. Measurements of soil gas migration around oil and gas wells in the Lloydminster area: *Journal of Canadian Petroleum Technology* **35(7)**, 37-46.

¹⁶⁵ Bexte, D.C., Willis, M., De Bruijn, G.G., Eitzen, B, Fouillard, E. 2008. Improved cementing practice prevents gas migration. *World Oil Magazine* **229(6)**, 73-75.

is generally straightforward to differentiate between shallow biogenic or coalbed methane and the deep gas found in unconventional oil and gas formations¹⁶⁶, so once a gas migration event has been identified during operations (by the company) or at a later date, sampling and analysis helps reveal the source and gives clues about the pathway. It is a standard regulatory requirement that the corporation that is producing the well report gas migration events. Once the source is located, perf-and-squeeze operations can be used to shut the pathway above the source and greatly reduce the chances of further gas seepage.

Although an undesirable event from a greenhouse gas and aesthetic perspective, the impact of methane entering potable water sources is not a serious health issue in comparison to many other chemical contaminants.¹⁶⁷ Gas in groundwater is a widespread natural phenomenon, especially in geological conditions where there are deep or shallow methane sources, such as coalbeds, intermediate depth gas accumulations, and other organic sources. The gas in water wells may even come from great depth under the right geological circumstances.^{168,169} Gas entering shallow groundwater wells may be a nuisance, including exceptionally an explosion hazard if gas accumulates in poorly ventilated spaces, but other than making groundwater unpalatable in some cases, no severe health impacts appear to have been demonstrated at this time.

However, a recurring issue in well integrity assurance and development of unconventional oil and gas in new areas is the lack of scientific-quality baseline groundwater data.¹⁷⁰ Often, the only data available are from local water wells which may be tapping only one zone or may be mixing water from several undifferentiated groundwater zones, or may be contaminated by organic matter in the well. If only this quality of data is available, it becomes more challenging to address cases where there is a concern over the source of methane (or other compounds) in the groundwater.

Another valuable source of information needed to address cases of claimed seepage of gas from energy wells into groundwater wells is good-quality data on the composition and geochemical nature of the gases in the ground. This information is relatively straightforward to collect through what is referred to as “mud-gas logging”, the collection of samples of gas released from the rocks during drilling.¹⁷¹ However, energy companies regard this information as strategic and therefore confidential. Means should be established in a regulatory framework to store this data with the regulator and make it available only under controlled conditions when claims are made related to fugitive gas emissions, in order to protect the resource owners (people of NL), the claimant, and the corporation.

Well Decommissioning and Long-Term Integrity

The Decommissioning Procedure

Once the commercial life of a shale oil well is over, and this is expected to be fifteen or more years, it must be decommissioned according to stipulated practices laid down by the regulatory body. If there is any detectable surface

¹⁶⁶ Molofsky L.J., Connor J.A., Wylie A.S., Wagner T., Farhat S.K., 2013. Evaluation of methane sources in groundwater in Northeastern Pennsylvania. *Groundwater* **51(3)**, 333-349.

¹⁶⁷ Goldstein B.D., Brooks, B.W., Cohen S.D., Gates A.E., Honeycutt M.E., Morris J.B., Orme-Zavaleta J., Penning, T.M., Snawder, J. 2014. FORUM on The Role of Toxicological Science in Meeting the Challenges and Opportunities of Hydraulic Fracturing. *Toxicological Sciences* **139(2)**, 271–283.

¹⁶⁸ Wilson B. 2014. Geologic and baseline groundwater evidence for naturally occurring, shallowly sourced, thermogenic gas in northeastern Pennsylvania. *American Association of Petroleum Geologists Bulletin* **98(2)**, 373-394.

¹⁶⁹ Stahl W., Faber E., Carey B.D., Kirksey D.L. 1981. Near-surface evidence of migration of natural gas from deep reservoirs and source rocks: *American Association of Petroleum Geologists Bulletin* **65(9)**, 1543-1550.

¹⁷⁰ Jackson R.E., Gorody A.W, Mayer B., Roy J.W., Ryan M.C., and Van Stempvoort D.R. 2013. Groundwater protection and unconventional gas extraction: the critical need for field-based hydrogeological research: *Groundwater* **51(4)**, 488-510.

¹⁷¹ Rowe, D. and Muehlenbachs, K. (1999). Isotopic fingerprints of shallow gases in the Western Canadian Sedimentary Basin: tools for remediation of leaking heavy oil wells. *Organic Geochemistry* **30**, 861-871.

casing vent gas flow, which occurs in perhaps 10-15% of wellbores¹⁷² before decommissioning, or evidence of seepage or loss of pressure integrity between the intermediate string and the production string, remediation must be implemented to reduce such flows to negligible values before the well is sealed. This would typically involve perf-and-squeeze of neat cement slurry into the location of the casing above where the gas is percolating. Cement bond logs, temperature logs, and noise logs may be used to identify the source of the gas migration to guide the location of the perforating action, and the well will have to be monitored for SCVF before decommissioning. Exceptionally, several perf-and-squeeze operations may be required to reduce seepage rates to mandated levels.

Perf-and-squeeze operations are less likely to be needed in Western Newfoundland than in regulatory jurisdictions in western Canada, for reasons discussed before and because general oilfield practice continues to improve. If they are required, there is a concern that in very stiff dense rocks, the high pressures needed to force the cement into the cement-rock system will tend to slightly wedge open natural fractures that could serve as future seepage pathways behind the casing. This opening of very small cracks in a stiff rock is perhaps less of a concern in jurisdictions such as Alberta where the rocks in the upper portion of the wells tend to be ductile and granular in nature (ductile shales, clayey high-porosity sandstones, porous coaly seams...). Better sealing agents that can flow into small cracks and which tend to wet the surfaces of the cracks would be more effective than cement to seal wellbores, but such materials (low viscosity resins for example) have not been widely adopted. As in many other cases, there is insufficient publicly available data on the efficacy of practices such as cement squeezing, and there is also a reluctance to adopt somewhat more demanding and expensive techniques for sealing wells. Although current practices generate good results, heightened public concern over issues such as gas migration would suggest that energy companies, regulators, and the public might benefit from enhanced developments in this area, and there is every reason to believe that better materials and methods could lower aggregate costs of well leakage and remediation.

Once these activities are done, or if the well has displayed no SCVF gas emissions and it is not necessary to attempt to seal the behind-the-casing pathway, the wellbore can be plugged and decommissioned. Plugging a well requires that the geological information for the well be used to locate zones above where plugs should be placed, and there are regulatory criteria that must be followed. Each plug includes a mechanical seal, a metal or polymer bridge plug or packer placed inside the casing, and an amount of cement sufficient to seal 30 to 50 m of the wellbore on top of the bridge plug. A number of these seals will be placed along the length of the production casing so that the interior of the wellbore is sealed.

Statistics are available on the total number of wells that have been drilled, that are active, that are suspended, and that have been plugged and decommissioned in Canada. Worldwide, the majority of wells drilled have been in the United States, over 2.5 million since 1950, and somewhat more than 500,000 in all of Canada (mainly in Alberta). Probably 70% of these wells have been plugged and decommissioned, and although there are many instances of gas migration, which must be fixed when noted, there do not seem to be major environmental problems arising from the existence of these decommissioned wells at this time. This is not an easy statement to verify because methane seepage has not been considered by toxicologists as an issue worthy of their attention, simply because it is considered non-toxic, therefore there is no "absolute proof" that methane seeping into groundwater has few to no health risk issues. The issue of proof and risk are challenging one to address to the satisfaction of everyone. For example, if a citizen asks for "proof that methane does not have any public health risk", all that realistically can be done is to look at what data are available, and even if the evidence that gas seepage is innocuous is overwhelming, opponents do not accept such conclusions readily, and continue to quote cases that are not relevant or that are not well understood.

¹⁷²In Alberta and British Columbia, surface casing vent flow data are registered with the regulatory agency; therefore, there are excellent statistics available in this area, in contrast to gas migration behind casing, where there are few data, insufficient to make strong quantitative conclusions. Other jurisdictions may not be as comprehensive in demanding full reporting of SCVF incidences as AB and BC, hence data from elsewhere are viewed as less reliable in comparison to data from western Canada.

There are many areas in the world (Pennsylvania, central Alberta, central Colorado, St Lawrence Lowlands, above most coal areas...) where natural seepage of methane is endemic, and major health concerns have not been identified at this time.¹⁷³ In any case, most jurisdictions have “orphan well” funds, provided by a levy on production, that are used to fix leaking wells for which an owner cannot be found; otherwise, the responsibility is that the owner fix the leaking decommissioned well to the standards set by the regulatory agency.

Long-Term Wellbore Integrity

Once a well is properly decommissioned and there is no detectable leakage, is there a chance that Pathways 3 and 4 could develop (Figure 45)? The answer to this question is yes: there is evidence that the development of slow gas migration can take place years after well decommissioning if a buoyant gas column develops behind the casing. In such cases, the gas seepage rate may be small, but it may remain entirely undetected if the gas is entering shallow aquifers rather than venting visibly at the surface. Furthermore, if gas migration is detectable at the surface, there is a very high probability, almost a certainty, that some gas is entering into sand aquifers behind the surface casing. In Alberta, especially in the Lloydminster area and the heavy oil fields of east-central Alberta, gas migration developing long after decommissioning is not uncommon. The gas seepage rates are low, and the environmental impacts are almost certainly small, but as mentioned previously, the incidence and rates of such events remains unquantified. Only if surface-visible evidence of a leaking well is noted and reported is it re-entered and re-sealed.

How long after decommissioning will the sealed wellbore integrity be maintained? The answer to this question is not well-known at present. Modern well cementation practices are barely 60 years old, and the life-span of steel in the ground, subjected to electro-chemical corrosion (the steel is a good electrode), is not known, nor is it known if gas migration pathways could develop once the casing has corroded and is breached in many places. The presence of strongly alkaline cement around the steel casing inhibits acidic reactions and therefore reduced that type of corrosion. This issue of long-term cement/steel integrity is a complex question that is also worthy of investigation, probably starting with assessment of some old wells in Ontario, New Brunswick and Alberta, for example. At the present time, there is no evidence of significant increases in the incidence of leaky wellbores with time, but the studies remain at the anecdotal level in large part because old wellbore sites are not subjected to systematic re-examination over time. As mentioned in the first section, the report issued in May 2014 by the Council of Canadian Academies (footnote 44) deals with many issues related in particular to shale gas wells, but which are also common to all conventional and unconventional oil and gas wells, including potential shale oil wells in Western Newfoundland.

¹⁷³It is important not to accept claims as proof. Many unverified claims may be found in the press, reported in electronic media, and even quoted by some professionals as evidence that something is happening. In regulatory systems in Canada, there are well-accepted ways of treating such claims with fairness (independent committees, third-party evaluations, scientific investigations...). Practices, claims, and legal proceedings in the United States involving privately-held energy resources and landowners cannot be extrapolated to Canada where resources are publicly owned and practices much more regulated.

Summary and Conclusions – Energy Well Integrity

Unconventional oil and gas development using modern well cementing and completion techniques leads to generally good wellbore performance, but there will never be a 100% success level in sealing all wellbores against all possibilities of future impairment. Continued technological advances are helping to reduce the incidence of well leakage through use of better quality casing (better threads in particular), improvements in cementing methods (for example more centralizers and scratchers, more consistent and denser cement formulation and placement, etc.), new materials for correcting leakage problems, better methods for detecting poor-quality cement behind the steel casing, even better methods of detecting slow methane seepage (or exceptionally oil seepage) around old decommissioned wellbores. Nevertheless, vigilance and explicit quality assurance practices are necessary to keep incidents of human error low, and to rectify problems that may have arisen because of such an error.

The most important integrity problem after wellbore decommissioning appears to be natural gas seepage along the outside of casing because of the buoyancy of the gas. The numbers of leaking decommissioned energy wells and the rates of leakage are not well-understood, and it appears that this varies with geology and geographical region (and probably age of well and quality of cement, etc.). Probably from a few percent to 10% of energy wells may be slowly leaking natural gas, most likely sourced from intermediate depth uncommercial gas zones rather than the zone that was exploited, and almost all such leaks are undetected because they are small or slow, or because the methane is not appearing at the surface. The public health and safety risks associated with inadequate well integrity are not great if the issue is only very slow methane seepage (e.g. less than 500 g/day), as shown by years of experience with hundreds of thousands of wells in the western provinces. Four known consequences exist: contamination of groundwater, turning it unpalatable; escape of natural gas to the atmosphere, where it has a greenhouse gas effect; chemical reactions that can lead to the release of other agents such as trace amounts of heavy metals into the water; and, direct safety risks associated with potential explosion of an accumulation of gas in a confined space. The latter is extremely rare and entirely avoidable with a properly vented well design. Groundwater impairment from natural methane occurrence is widely known but apparently not common in Western Newfoundland (this should be verified). Verified contamination from energy well sources also appears to be extremely rare, even in regions with wide-spread shale gas developments. Although not desirable, groundwater souring is not a serious public health issue because methane and its decomposition products are not toxic, and tens of thousands of groundwater wells in North America have methane naturally present in free form or dissolved in the water without evidence of health effects. For example, in regions above shallow coal beds in Wyoming or Alberta, and even in the St Lawrence Lowlands, many wells naturally have methane present, yet the water is used for domestic consumption.

The greenhouse gas effect of escaping methane is well-known, but the amount escaping into the atmosphere from energy wells can be shown, by simple estimates and calculations, to be small compared with other well-defined sources (e.g., automotive fuels, city natural gas transmission systems, coal mining and combustion, cattle husbandry, natural seepage), and good practices in primary well cementation and decommissioning should reduce gas migration to substantially lower levels than at present. Finally, ancillary effects such as triggering the release of other agents appear to be rare issues in practice. Nevertheless, their quantification is recommended, as when something is being measured, it is far easier to control and reduce the incidence of negative consequences.

Because any possible unconventional oil development in Western Newfoundland would take place using modern technology with multiple wellbores installed at each drilling site, it is a relatively straightforward task to establish good regulatory practices in advance to ensure that the site is geologically understood, that wells are properly installed with good quality assurance, that well decommissioning is done according to best practice guidelines, and that the groundwater is monitored. The mature practices of jurisdictions such as Alberta can serve as a guide to the establishment of an onshore regulatory system in Newfoundland, with modifications as deemed necessary by local regulators, scientists and engineers. Operators are required to be vigilant and collect relevant environmental data (e.g., groundwater quality, gas analyses, cementation reports). Data should be made public so that industrial activities and impacts may be subject to transparent oversight to assure citizens that environmental and rights protection is taking place.

Developments in regulatory practices continue to be made. For example, a multi-level groundwater monitoring well at each multi-well drilling site may be required in the future in some jurisdictions, and is currently being debated in the regulatory world. If this is mandated, the well should be installed under the supervision of a licensed third-party professional before the first borehole is drilled, and the groundwater well should be sampled and analyzed initially and each two to three years thereafter and until perhaps ten years after the last well is decommissioned. In this way, a problem with energy wellbore integrity that impacts groundwater could be identified soon and corrective measures taken before a more severe problem develops over a larger area. Because each unconventional oil and gas multi-well pad would be draining the gas from an area of several square kilometers ($\approx 6-12 \text{ km}^2$), the number of sites will remain few and fairly widely spaced, so that it is far easier to detect issues and rectify them.

As has happened repeatedly in many other jurisdictions, Western Newfoundland's shale oil regions can be developed with hydraulic fracturing safely, and the use of modern practices should lead to a much lower incidence of impaired wellbore integrity compared to historical practices in other jurisdictions. Nevertheless, all industrial activities carry some level of risk, and the balancing of risks and rewards is an important government role, and the regulation of complex technologies must be done based on excellent science, with continued vigilance and regulatory oversight with rapid enforcement.