

# Review of the Newfoundland and Labrador Electricity System

Prepared for:

Newfoundland and Labrador  
Department of Natural Resources

October 26, 2015



[poweradvisoryllc.com](http://poweradvisoryllc.com)

978-369-2465

Hatch Ltd.

# 1. Table of Contents

Executive Summary .....	ES-1
Introduction .....	ES-1
The Focus of the Review.....	ES-1
Jurisdictional Review .....	ES-5
Review of Electricity Sector Legislation .....	ES-6
Review of Agencies with Oversight over Newfoundland and Labrador Electricity Sector .....	ES-7
Department of Natural Resources .....	ES-7
Board of Commissioners of Public Utilities .....	ES-7
Consumer Advocate .....	ES-9
Summary of Governance and Regulatory Best Practices .....	ES-9
Electric Power System Fundamentals .....	ES-13
Electric Power Systems - Isolated and Interconnected .....	ES-14
Electric Industry Reliability Organizations.....	ES-15
Electric Power System Reliability Criteria .....	ES-15
Energy Efficiency Programs .....	ES-17
Load Forecasting.....	ES-17
Investment Planning.....	ES-17
Asset Management.....	ES-18
System Operations .....	ES-18

## Part 1 - Overview

1. Introduction .....	20
1.1 Scope of Review and This Report .....	20
1.1.1 Role of Consulting Team.....	21
1.2 Approach Followed in Preparing this Report.....	21
1.3 Contents of Report.....	21
2. Overview of Newfoundland and Labrador Electricity Sector.....	23
2.1 Broad Overview of Sector .....	23
2.2 Electricity System Composition .....	24
2.2.1 Island Interconnected System .....	24
2.2.2 Labrador Interconnected System and Labrador West System.....	34
2.2.3 Isolated Systems .....	39
2.3 Electricity Supply and Distribution Service .....	42
2.3.1 Nalcor Energy .....	42
2.3.2 Newfoundland and Labrador Hydro .....	42
2.3.3 Churchill Falls.....	45
2.3.4 Lower Churchill Project.....	47
2.3.5 Newfoundland Power .....	47
2.3.6 Non-Utility and Industrial Generators .....	52
2.4 Development of Muskrat Falls .....	53
2.5 Forecast of Future Energy Requirements .....	58
2.6 Electricity Rates in Newfoundland and Labrador .....	62

2.6.1	Analysis of Rate Drivers.....	64
2.7	Summary.....	68
3.	Review of Electricity Sector Legislation, Agencies with Oversight and Major Changes to Sector.....	70
3.1	Electricity Sector Legislation.....	70
3.1.1	<i>The Electrical Power Control Act</i> .....	70
3.1.2	<i>The Public Utilities Act</i> .....	72
3.1.3	<i>Hydro Corporation Act</i> .....	73
3.1.4	<i>Energy Corporation Act</i> .....	73
3.1.5	Other Ancillary Legislation.....	73
3.2	Review of Agencies with Oversight over Electricity Sector.....	74
3.2.1	Department of Natural Resources.....	74
3.2.2	Board of Commissioners of Public Utilities.....	76
3.2.3	Consumer Advocate.....	79
3.3	Changes to Electricity Sector since <i>EPCA</i> Enacted.....	80
3.3.2	Changes to North American Electricity Sector Since <i>EPCA</i> Enacted.....	81
3.4	Summary.....	88
 Part 2 - Legislation/Regulation		
4.	Review of Canadian Provinces Governance, Legislation and Regulations.....	89
4.1	British Columbia.....	89
4.1.1	Legislative Review.....	90
4.1.2	BC Hydro Review.....	94
4.1.3	Industrial Electricity Policy Review.....	95
4.1.4	BCUC Review.....	96
4.2	Alberta.....	97
4.2.1	Major Electricity Sector Institutions.....	98
4.2.2	Transmission Infrastructure.....	99
4.2.3	Market Reforms.....	101
4.3	Saskatchewan.....	101
4.4	Manitoba.....	104
4.4.1	Provincial Legislation.....	106
4.5	Ontario.....	109
4.5.1	Legislation.....	109
4.5.2	Major Electricity Sector Agencies.....	110
4.5.3	Ministerial Directives.....	113
4.5.4	NERC Reliability Obligations.....	113
4.5.5	Ongoing Efforts to Rationalize Ontario’s Electricity Sector.....	115
4.6	Quebec.....	117
4.6.1	Ministère des Ressources naturelles.....	119
4.6.2	Régie de l’énergie.....	119
4.6.3	HQ Energy Services (U.S.).....	120
4.6.4	Legislative Review.....	121
4.6.5	NERC Reliability Obligations.....	121
4.6.6	FERC Obligations and Québec’s Participation in Export Markets.....	122
4.7	New Brunswick.....	123
4.7.1	Organization of NB Power.....	123

4.7.2	Legislation .....	124
4.7.3	The New Regulatory Framework .....	125
4.8	Prince Edward Island.....	127
4.8.1	Island Regulatory and Appeals Commission.....	128
4.8.2	Legislative Review .....	128
4.8.3	Maritime Electric’s Open Access Transmission Tariff .....	129
4.8.4	PEI Energy Accord .....	129
4.8.5	PEI Energy Commission.....	130
4.9	Nova Scotia .....	130
4.9.1	Legislative Review .....	131
4.9.2	NERC Reliability Obligations .....	133
4.9.3	Integrated Resource Plans.....	133
4.9.4	Efficiency Nova Scotia .....	134
4.10	Summary and Conclusions .....	134
5.	Assessment of Agencies with Oversight over Electricity Sector .....	137
5.1	Assessment of the PUB .....	137
5.2	Assessment of Consumer Advocate .....	143
6.	Governance and Regulatory Best Practices.....	146
6.1	Governance.....	146
6.1.1	Clearly Articulate Government Objectives for the Crown Corporation.....	147
6.1.2	Attract Directors with Desired Skills and Experience.....	148
6.1.3	Develop the Knowledge and Understanding of Board Members .....	149
6.1.4	Have Independent Appointment Process for NLH Board and CEO .....	150
6.2	Regulatory Oversight.....	150
6.2.1	Employing a Public Interest Test.....	151
6.2.2	Employing Outcome-Based Policy Direction.....	152
6.2.3	Utilizing the Regulatory Process to Review the Need and Cost-Effectiveness of New Resource Options .....	153
6.2.4	Providing Oversight over Resource Planning.....	154
6.2.5	Employing a Capital Budget Review Process .....	155
6.2.6	Appropriate Weight and Attention Given to Rate Regulation Function .....	156
6.2.7	Ensuring Appropriate Balance to the Rural Subsidy.....	157
6.2.8	Ensuring Timely Rate Review Processes .....	158
6.3	Commercial Issues regarding Integrating Major Hydroelectric Facilities .....	159
6.3.1	Ensuring Sufficient Resources are Devoted to Participation in Export Markets.....	159
6.3.2	Enabling Appropriate Transmission Access.....	160
6.3.3	Providing Appropriate Degree of Functional Separation of System Operator Functions.....	163
6.3.4	Enabling Oversight of Long-term Export Contracts.....	163
6.3.5	Protecting the Benefits of NLH’s Hydroelectric Generation to Customers .....	164
6.4	Electricity Sector Institutions .....	166
6.4.1	Ensuring Appropriate Levels of Investment in Energy Efficiency and Demand Management.....	166
6.5	Summary of Best Practices.....	166

## Part 3 - Reliability

7. System Reliability .....	172
7.1 Introduction .....	172
7.2 Reliability Targets Used for Planning and Key Planning Parameters.....	173
7.2.1 Generation System Planning.....	173
7.2.2 Transmission System Planning.....	177
7.2.3 Distribution System Planning .....	182
7.2.4 Planning of Remote Isolated Micro Systems.....	183
7.3 Operational Reserves.....	183
7.3.1 Operating Reserve.....	183
7.3.2 Maintaining Spinning Reserves.....	184
7.3.3 Available Generation Reserve .....	184
7.3.4 Post Interconnection of Muskrat Falls Hydroelectric Plant.....	186
7.3.5 Interconnection with Nova Scotia System.....	187
7.4 NERC Reliability Standards.....	187
7.4.1 Overview.....	187
7.4.2 Application to Canadian Provinces.....	188
7.4.3 Assessment.....	191
7.4.4 NLH Review to Date .....	191
7.4.5 NPCC Regional Reliability Criteria .....	195
7.4.6 Benefits and Costs from NERC and NPCC Compliance .....	196
7.5 Failure Modes.....	199
7.5.1 Generation Forced Outage Rates.....	199
7.6 Coordination.....	200
7.7 Service Reliability in Newfoundland and Labrador.....	200
7.7.1 Generation Outage and Availability Measures.....	201
7.7.2 Transmission and Distribution Reliability Measures.....	202
7.7.3 Island Interconnected System: Challenges of Isolated System .....	203
7.7.4 NL Service Reliability Measures.....	205
7.7.5 Comparison of Distribution Service Reliability .....	223
7.7.6 Summary and Conclusions Regarding Service Reliability.....	224
8. Load Forecasting.....	226
8.1 Energy Efficiency.....	226
8.2 Load Forecasting .....	228
8.2.1 Short-term Forecast.....	228
8.2.2 Medium-Term Forecast .....	229
8.2.3 Long-Term Forecast .....	229
8.2.4 Peak Load Forecast.....	232
9. Investment Planning.....	233
9.1 Regulatory Requirements .....	233
9.2 Capital Budgeting Process.....	234
9.3 Recent Capital Budget Applications.....	237
9.3.1 NLH.....	237
9.3.2 NP .....	238
9.4 Capital Budget Preparation.....	238
9.4.1 NLH.....	239
9.4.2 NP .....	243

9.5	Long-term Planning.....	243
10.	Asset Management .....	246
10.1	Summary of Existing Assets.....	246
10.1.1	NLH .....	246
10.1.2	NP .....	246
10.2	Asset Management Strategy .....	249
10.2.1	NLH .....	249
10.2.2	NP .....	250
10.3	Asset Management Process .....	251
10.3.1	NLH .....	251
10.3.2	NP .....	254
11.	System Operations.....	256
11.1	Operations Planning.....	256
11.2	Operations Planning – Planned System Equipment Outages .....	257
11.2.1	Outage Request .....	257
11.2.2	Outage Approval.....	259
11.2.3	Deviation from Standard.....	259
11.2.4	Forced Removal of Equipment .....	259
11.2.5	Preparation for Winter Readiness .....	259
11.3	Generation Dispatch .....	260
11.4	Daily Operation Coordination .....	261
11.5	Demand Response Program.....	261
11.6	Response to Emergency Conditions .....	262
11.6.1	NLH .....	262
11.6.2	NP .....	264
12.	Conclusions .....	265
	Appendix A: Glossary.....	267
	Appendix B: Generation Asset Summary Table.....	270
	Appendix C: Electricity System Demand Summary Table.....	274
	Appendix D: Electricity System Reliability Metrics Table .....	275
	Appendix E: Calculation of LOLP versus LOLH.....	276
	Appendix F: Cost Comparison with Interruption Damage Cost.....	278
	Appendix G: Forced Outage Rates .....	279
	Appendix H: Incremental Cost of a Higher Level of Reliability Criterion.....	282

## 2. List of Tables

Table 1: Island Interconnected System Supply (MW).....	25
Table 2: Labrador Interconnected System Generation Resources .....	35
Table 3: Average Electricity Prices by Canadian Cities on April 1, 2014.....	64
Table 4: NLH and NP Capital Budgets.....	66
Table 5: NLH and NP Capital Budget Forecasts .....	66
Table 6: Exemptions from all or portion of EPCA .....	76
Table 7: Summary of Electricity Market Structures in Canadian Provinces .....	136
Table 8: Operating Costs and Staffing Levels at Public Utility Commissions across Canada.....	138
Table 9: PUB and Consumer Advocate Annual Hearings Expense .....	144
Table 10: Weighted Capacity Factory Performance .....	206
Table 11: DAFOR Performance.....	207
Table 12: CEA Annual Report Generation Equipment.....	208
Table 13: NERC GADS - Forced Outage Rate (FOR) .....	209
Table 14: Under Frequency Load Shedding Unsupplied Energy (MW-min).....	215
Table 15: NP SAIDI Normal Operations and Significant Events.....	219
Table 16: NP SAIFI Normal Operations and Significant Events .....	220
Table 17: NP SAIFI by Cause.....	220
Table 18: NP CAIDI by Cause.....	222
Table 19: Capital Budget Application Schedule.....	234
Table 20: NLH Capital Budget Preparation Time Line .....	241
Table 21: NLH Transmission Facilities by Age .....	247
Table 22: NLH Distribution Facilities by Age.....	247
Table 23: Distribution of NP Transmission and Distribution Facilities by Age.....	248
Table 24: Distribution of NP Transformers by Age.....	248

## 3. List of Figures

Figure 1: IIS Hourly Load: Peak and Low Load Days .....	27
Figure 2: IIS Monthly Peak and Energy Requirements .....	28
Figure 3: IIS Annual Load Duration Curve: 2014 .....	29
Figure 4: Annual Energy Requirements for Island Interconnected System (GWh) .....	30
Figure 5: Total Island System Energy Requirements (GWh) .....	30
Figure 6: Total Island Interconnected System Peak (MW).....	31
Figure 7: NLH Provincial Generation and Transmission Grid .....	33
Figure 8: IIS Transmission Network after ML and LIL .....	34
Figure 9: Labrador Electricity System Map.....	36
Figure 10: LIS Hourly Load Curves: Peak and Low Load Day .....	37
Figure 11: LIS Monthly Load and Energy Requirements.....	38

Figure 12: LIS Annual Load Duration Curve .....	38
Figure 13: Labrador Annual Energy Requirements (GWh).....	39
Figure 14: Isolated Diesel System Annual Energy Requirements (GWh).....	40
Figure 15: Newfoundland and Labrador Hydro Isolated Diesel System Map.....	41
Figure 16: NLH Generation Capacity by Fuel Type (MW).....	44
Figure 17: NLH Age of Generating Assets.....	45
Figure 18: Newfoundland Power Service Territory.....	48
Figure 19: Newfoundland Power System Peak Demand (MW).....	49
Figure 20: NP Annual Energy Sales (GWh).....	49
Figure 21: Newfoundland Power Generation Capacity by Fuel Type (MW).....	50
Figure 22: Newfoundland Power Age of Generating Assets by Type of Units.....	51
Figure 23: Newfoundland Power Age of Generating Assets by Capacity.....	51
Figure 24: Newfoundland Power Transmission Assets by Vintage.....	52
Figure 25: Muskrat Falls Development.....	55
Figure 26: Forecast Island Interconnected System Energy Requirements (GWh).....	58
Figure 27: Forecast Island Interconnected System Peak (MW).....	59
Figure 28: Labrador Interconnected System Forecast .....	60
Figure 29: Labrador-Island Transmission Link .....	60
Figure 30: Annual Energy Requirement for LIS and IIS.....	61
Figure 31: Combined Peak Demand Forecast for IIS and LIS (MW) .....	62
Figure 32: Costs of Electricity Service .....	65
Figure 33: NLH and NP 2009-2013 Capital Budgets and 2014-2018 Capital Expenditure Forecasts.....	67
Figure 34: NLH Capital Budget Forecast Separated by Major Projects.....	68
Figure 35: NERC Regions .....	85
Figure 36: BC Shareholder and Regulatory Relationship Framework .....	92
Figure 37: Hydro One Networks Inc. Organizational Chart.....	88
Figure 38: Summary of the Powers of the Régie de l'énergie .....	120
Figure 39: Key Factors in Meeting Customer Requirements.....	172
Figure 40: Weighted Capability Factor (WCF) Performance 2004 to 2013.....	205
Figure 41: Weighted DAFOR Performance 2004 to 2013.....	207
Figure 42: Outage Duration (T-SAIDI) Forced & Planned Outages .....	210
Figure 43: Total Outage Duration (minutes) from 2009 to 2013 by Voltage Class .....	210
Figure 44: NLH T-SAIDI by Interconnected System.....	211
Figure 45: T-SAIFI Forced & Planned Outages .....	212
Figure 46: NLH T-SAIFI Interconnected Systems.....	212
Figure 47: Number of Interruptions by CEA Cause Code from 2009 to 2013 .....	213
Figure 48: T-SARI Forced & Planned Outages .....	214
Figure 49: Under Frequency Load Shedding Events .....	214
Figure 50: NLH D-SAIDI.....	216
Figure 51: NLH Distribution Customer Minutes of Interruption.....	216
Figure 52: NLH SAIFI.....	217
Figure 53: NLH Distribution Customer Interruption from 2009 to 2013 .....	218
Figure 54: Comparison of Reliability Indices for NLH and NP .....	224
Figure 55: Nalcor Asset Management Framework.....	251



## 4. Abbreviations

AESO	Alberta Electric System Operator
AUC	Alberta Utilities Commission
BCTC	British Columbia Transmission Company
BCUC	British Columbia Utilities Commission
CAGR	Compound Annual Growth Rate
CEA	Clean Energy Act (British Columbia)
CIC	Crown Investment's Corporation (Saskatchewan)
CTI	Critical Transmission Infrastructure
DOE	Department of Energy
DSM	Demand Side Management
FERC	Federal Energy Regulatory Commission
IES	Integrated Electricity System (New Brunswick)
IESO	Independent Electricity System Operator
ISO-NE	Independent System Operator-New England
IPP	Independent Power Producers
IRAC	Island Regulatory and Appeals Commission (Prince Edward Island)
IRP	Integrated Resource Plan
LDC	Local Distribution Company
MAPP	Mid-continent Area Power Pool
MATL	Montana-Alberta Tie Line
MISO	Midcontinent Independent System Operator
MOA	Memorandum of Agreement
MOU	Memorandum of Understanding
MRO	Midwest Reliability Organization
MSA	Market Surveillance Administrator (Alberta)
NERC	North American Electric Reliability Corporation
NFAT	Needs For and Alternatives To
NPCC	Northeast Power Coordinating Council
NSPI	Nova Scotia Power
NSUARB	Nova Scotia Utility and Review Board
OATT	Open Access Transmission Tariff
OEB	Ontario Energy Board
OEFC	Ontario Electricity Financial Corporation
OPA	Ontario Power Authority
OPG	Ontario Power Generation
ORCP	Ontario Reliability Compliance Program
PUB	Public Utilities Board
RC	Reliability Coordinator
RTO	Regional Transmission Organizations
UCA	Utilities Consumer Advocate (Alberta)

# **Executive Summary**

## **Introduction**

The Newfoundland and Labrador electricity system is largely isolated from the North American electricity grid, which is highly interconnected. While the Churchill Falls hydroelectric project in Labrador is interconnected to Québec, there are no interconnections between Labrador and Newfoundland, and as such these two systems operate independently. As a largely isolated electricity system, electricity supply planning standards and operating practices in Newfoundland and Labrador in a number of areas are different than those of most other electric utilities in North America. Other electric utilities in North America have interconnections with adjacent systems which can be relied upon to provide power during low probability events such as multiple generator or transmission line outages and extreme weather. This allows these interconnected systems to achieve higher reliability levels at a lower cost.

With the development of the Muskrat Falls hydroelectric project, Newfoundland and Labrador will be connected and the province will be interconnected to Nova Scotia and the greater North American electricity grid. This will represent a major change to the province's electricity system; present opportunities to realize higher reliability at a lower cost; and create new opportunities for the export of power when it is surplus to the province's needs.

## **The Focus of the Review**

In January 2014 the Government of Newfoundland and Labrador announced an independent review “to look at the current electricity system in Newfoundland and Labrador – how it operates, is managed and regulated as the province moves from an isolated system to an interconnected system.” Power Advisory LLC (Power Advisory) was engaged by the Department of Natural Resources to undertake this review.<sup>1</sup>

The focus of this project is to present options to support the province's interest in ensuring that its electricity system: (1) has the optimal structure, governance and regulatory processes as it transitions from an isolated system to a North American interconnected system; and (2) is positioned to maximize value over the long term from electricity available for export by maintaining access to these export markets.

## **Overview of Electricity System**

The Newfoundland and Labrador electricity system has nearly 7,500 MW of electrical generating capacity and serves approximately 290,000 customers. This generating capacity includes hydroelectric, residual oil-fired, wind, biomass and diesel generation. The province's electricity customers are connected to the Island Interconnected System (IIS), which includes the major

---

<sup>1</sup> Power Advisory partnered with Hatch Ltd. (Hatch) to provide this review.

population centers on the Island of Newfoundland (Island); the Labrador Interconnected System; or one of 21 isolated diesel systems located in coastal communities.

Electricity supply and distribution service in the province is primarily provided by two utilities: Newfoundland and Labrador Hydro (NLH, a subsidiary of Nalcor Energy) and Newfoundland Power (NP). The *Energy Plan* of 2007 outlined that the Energy Corporation of Newfoundland and Labrador, later branded as Nalcor Energy (Nalcor), would play “a lead role in the province’s participation in the development of our energy resources...will be wholly owned by the province and will be the parent company of Newfoundland and Labrador Hydro (NLH), Churchill Falls Labrador (CF(L)Co) Corporation, other subsidiaries currently owned by NLH and new entities created to manage the province’s investments in the energy sector.”

Nalcor has six primary lines of business: NLH, Churchill Falls, Oil and Gas operating as Nalcor Energy – Oil and Gas Inc., Lower Churchill Project, Bull Arm Fabrication operating as Nalcor Energy – Bull Arm Fabrication Inc., and Energy Marketing. The President and Chief Executive Officer of Nalcor also serves in these roles for each of these businesses. Nalcor provides functional support to these lines of business in the areas of finance, strategic planning and business development, engineering, human resources, communications, legal and audit.

NLH is primarily an electricity generation and transmission organization that operates the larger generation and transmission assets in the province. In Labrador, NLH undertakes generation, transmission and distribution of electricity. NLH also distributes power to rural customers on the Island. A majority of NLH’s generation assets are hydroelectric, representing over 50% of its generation capacity. Once Muskrat Falls comes into service 98% of the province’s electricity generation will come from renewable generation.<sup>2</sup> The remaining NLH generation assets are thermal generation, with the oil-fired Holyrood generating station representing the majority of this thermal generation. Two of the three Holyrood units are over 40 years old and the third is 35 years old, which is significant, given the planned operating life for many thermal units is 35 years. The age of these units increases the importance of appropriate maintenance practices and can contribute to poor reliability of the generating station. As a residual oil-fired station, greenhouse gas and sulphur dioxide emissions have been a source of environmental and health concerns.

NP is primarily an electricity distribution company and serves the vast majority of customers on the Island. NP purchases the majority of its power from NLH, but generates a portion of its customers’ requirements from facilities that it owns.

In addition to NLH and NP, there are other entities within the province that provide generation and transmission service. These include Churchill Falls (Labrador) Corporation Limited (CFLCo), which owns and operates the Churchill Falls hydroelectric facility, which has a rated capacity of 5,428 MW. A significant portion of the electricity produced by Churchill Falls is sold to Hydro-

---

<sup>2</sup> The Muskrat Falls project has been structured such that a Nalcor subsidiary other than NLH will own the generation plant with energy being made available to NLH under a long term Power Purchase Agreement.

Québec under long-term contracts, with the balance available to customers in Labrador and for export through Québec. CFLCo is jointly owned by NLH (65.8%) and Hydro-Québec (34.2%). CFLCo has two consecutive power sale agreements with Hydro-Québec. The initial CFLCo contract with Hydro-Québec expires in 2016, and a twenty-five year renewal contract expiring in 2041. Under this Power Contract, CFLCo is required to make available to Hydro-Québec approximately 4,100 MW in the winter and 3,860 MW in the summer subject to limitations of the 225 MW Twinco Block and 300 MW Recall Block which may be withheld by CFLCo.<sup>3</sup> The current contract price is approximately \$2.50/MWh. This price is valid until 2016 when the renewal contract at \$2.0/MWh takes effect. After expiration of the contract with Hydro-Québec in 2041, CFLCo will be able to sell the approximately 30 million MWh per year from Churchill Falls at market rates. Hydro-Québec will continue to own a 34.2% interest in CFLCo.

With no transmission connection between Labrador and the Island, any surpluses from Churchill Falls currently cannot be made available to the Island. However, with the development of the 824 MW Muskrat Falls hydroelectric project on the lower Churchill River in Labrador, the Labrador Transmission Assets, which will connect Muskrat Falls and Churchill Falls, and the Labrador-Island Link, which will interconnect Labrador and Newfoundland, energy and capacity in Labrador will be able to be used to serve customers on the Island.

Reflecting the different electricity systems in the province, there are five distinct costs of service for customers in Newfoundland and Labrador: (1) Island Interconnected System; (2) Island Isolated System; (3) Labrador Interconnected System; (4) Labrador Isolated System; and (5) L'Anse au Loup System. Domestic customers on the three isolated systems receive an initial block of energy that is priced at the same level as that paid by other domestic customers on the relevant interconnected system (i.e., Island or Labrador) as a result of ratepayer and Government subsidies (i.e., the Northern Strategic Plan).

A comparison of residential rates for homes using 1,000 kWh/month in 14 Canadian cities, including St. John's, is presented in Figure ES-1 below. Newfoundland and Labrador has the sixth lowest residential electricity rates among these cities, based on the electricity rates for the Island Interconnected System. Interestingly, the cities with the three lowest residential rates are served by predominately hydroelectric Crown-owned utilities.

Increasing investment to replace and refurbish the province's aging infrastructure is likely to contribute to increases in electricity rates in the future. These same rate pressures are being experienced across Canada. Where large capital projects can cause significant short-term rate increases, it is common practice to spread out the impacts over a longer period of time where possible.

---

<sup>3</sup> The Twinco obligations expired on December 31, 2014, but the CFLCo contract still ensures that this energy is available to industrial customers in Labrador. NLH has 265 MW of firm transmission rights on the Hydro-Québec TransÉnergie system, which it can use to deliver energy from CFLCo to export markets.

**Figure ES-1: Residential Electricity Rate Comparison**

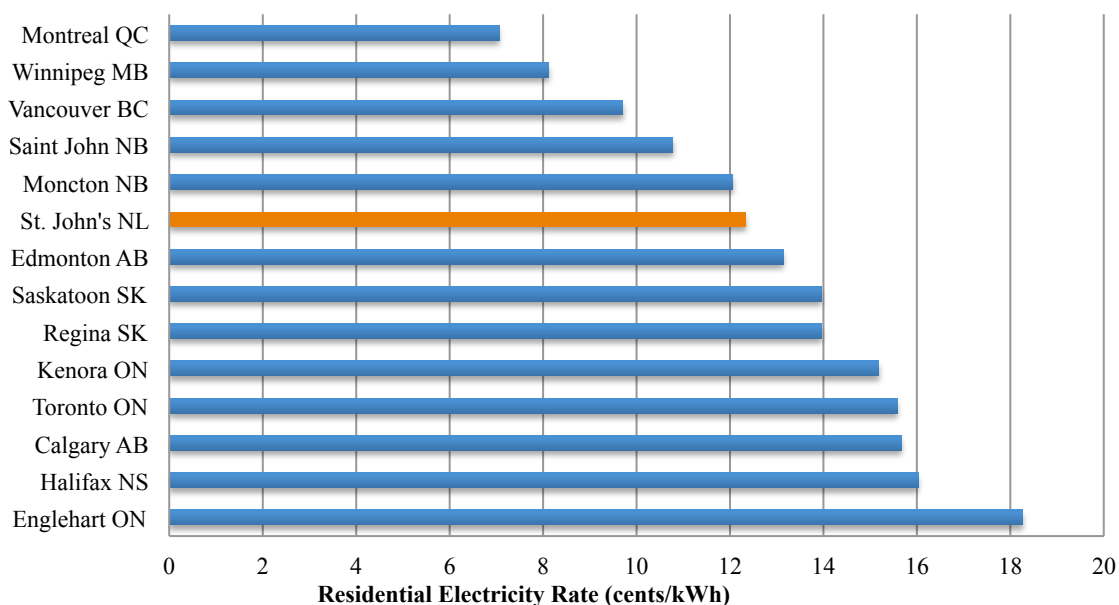

Source: Manitoba Hydro, *Utility Rate Comparison*, 2014. Available at: [https://www.hydro.mb.ca/regulatory\\_affairs/energy\\_rates/electricity/utility\\_rate\\_comp.shtml](https://www.hydro.mb.ca/regulatory_affairs/energy_rates/electricity/utility_rate_comp.shtml).

### Changes to Newfoundland and Labrador’s Electricity Sector

One of the most significant reforms to Newfoundland and Labrador’s electricity sector was the enactment of *The Electrical Power Control Act, 1994 (EPCA)*, which put NLH on a full commercial basis, with formal financial reporting and subjected it to full regulatory oversight by the Newfoundland and Labrador Board of Commissioners of Public Utilities (PUB) similar to NP. The PUB sets rates based on the cost of providing service. Prior to this there were no formal PUB orders on NLH’s rates, just recommendations to government who had final authority over rates. NLH’s experience mirrors that of other Crown-owned electric utilities who have typically migrated from oversight by government to formal regulatory oversight by independent regulators who apply traditional cost-of-service regulation principles to rate setting.

Since the *EPCA*, possibly the most significant legislative change in the electricity sector has been the introduction of the *Energy Corporation Act*, which ultimately resulted in the creation of Nalcor to “take a lead role in the province’s participation in the development of our energy resources.”<sup>4</sup> This Energy Corporation was to be the parent company of NLH, CFLCo, and new entities established to manage the Province’s investments in the energy sector. As a holding company, it provided a structure that permits both regulated (e.g., NLH) and non-regulated entities to exist and grow within separate legal entities. This enabled the vehicle that the Province used to pursue the development of offshore oil and the Lower Churchill project.

<sup>4</sup> Newfoundland and Labrador, *Energy Plan (2007)*, p. 14.

## **Development of Lower Churchill**

The Lower Churchill Project is composed of two sites on the Churchill River in Labrador downstream from the Churchill Falls hydroelectric generation facility. The first phase of Lower Churchill development is the 824 MW Muskrat Falls project which is under construction and includes the Muskrat Falls generating station, the Labrador Transmission Assets, the Labrador-Island transmission link to deliver the project's energy to the Island and the Maritime transmission link to allow surplus energy to be sold to Eastern Canada and beyond. The second phase of Lower Churchill development will be the larger 2,250 MW Gull Island hydroelectric project upstream from Muskrat Falls.

For the first phase of the project, the Power Purchase Agreement (PPA) between NLH and Muskrat Falls Corporation provides for the purchase by NLH and the sale by Nalcor subsidiary Muskrat Falls Corporation of energy, capacity, ancillary services and greenhouse gas credits. Muskrat Falls Corporation will provide to NLH energy based on a forecast of its requirements for energy from the project, with payments based on the project's capital and operating costs and structured to recover its full costs. Under the PPA the monthly capital costs escalate over time, reducing the initial rate impacts to Newfoundland and Labrador customers.

In addition, Nalcor executed various agreements with Emera Inc, parent of Nova Scotia Power, for the construction of the Maritime Link, which will interconnect the Island of Newfoundland with Nova Scotia, and the provision of energy and capacity from Muskrat Falls. In return for building the Maritime Link and providing Nalcor with transmission service on the Maritime Link and through Nova Scotia, an Emera affiliate will receive 20% of the energy from Muskrat Falls.

Beyond Muskrat Falls Corporation's sales obligations to NLH and Emera, additional energy will be available for resale in various export markets including Nova Scotia (for energy beyond the Nova Scotia Block), New Brunswick, PEI, Quebec and the US Northeast. Therefore, maintaining access to these markets will be important to ensuring that the full value of Muskrat Falls is realized. With the growth in Newfoundland and Labrador electricity requirements, the amount of energy from Muskrat Falls available for sale in these export markets is forecast to decline.

## **Jurisdictional Review**

To provide context for our review of the governance, legislation and regulation of Newfoundland and Labrador's electricity market a review of other Canadian jurisdictions was undertaken. Most utilities in Canada are faced with the challenges associated with replacing aging infrastructure, meeting future growth in customer requirements, and managing rate increases, while ensuring favourable access to needed capital. These challenges can be most significant for Crown utilities that are highly levered and as a result have reduced cash flow to fund such investments.

There are a range of viable and effective electricity sector structures employed across Canada. Those employed in the predominately hydro jurisdictions (i.e., BC, Manitoba and Québec) are among the most relevant to Newfoundland and Labrador as it becomes a predominately hydroelectric system. Both BC and Québec have opted for heritage pools or contracts, which effectively ring-fence existing facilities and guarantee the benefits of low cost energy from these facilities to customers. In Québec the structure results in the risks and rewards of new facilities being borne by the shareholder, rather than customers.

These predominately hydroelectric utilities have pursued different strategies for serving domestic customers and pursuing export opportunities. These differences are dictated in part by the differences in the hydraulic resources, market access, and market volatility. The significant storage capability of Hydro-Québec has allowed it to participate opportunistically in these markets and enhance the value of its hydroelectric facilities. With a heritage pool to protect customers and ready access to export markets, Hydro-Québec offers its customers low rates and has been able to provide significant dividends to its shareholder, the government.

### **Review of Electricity Sector Legislation**

*The Electrical Power Control Act, 1994 (EPCA)* sets the electricity policy of the province with respect to electricity rates, criteria for the production, transmission and distribution of electricity, and gives the Board of Commissioners of Public Utilities (PUB) the authority to implement these policies, but with provisions for direction from the government by the Lieutenant-Governor in Council (Lieutenant Governor). The *EPCA* also specifies that “all sources and facilities for the production, transmission and distribution of power in the province should be managed and operated in a manner (i) that would result in the most efficient production, transmission and distribution of power, (ii) that would result in consumers in the province having equitable access to an adequate supply of power, and (iii) that would result in power being delivered to consumers at the lowest possible cost consistent with reliable service.”

In addition, the *EPCA* gives the PUB authority and responsibility to ensure adequate planning by the utilities for the future production, transmission, and distribution of power in the province and to direct utilities to perform such activities and provide such information as it considers necessary under terms and conditions it may prescribe.

The *EPCA* provides for the Government to refer to the PUB issues associated with electricity rates and more broadly any general matters related to electricity. Since the mid-1990s major supply additions have typically been exempted from PUB oversight under various directives. This practice is common throughout Canada.

In 2012 to facilitate financing for the Muskrat Falls project, legislative amendments were enacted to: (1) expand the scope of the direction that the Lieutenant Governor may give the PUB regarding the Muskrat Falls project; (2) provide NLH with the exclusive right to supply and sell electricity to

retailers and industrial customers in the IIS; and (3) require retailers (e.g., NP) and industrial customers in the IIS to buy electricity exclusively from NLH.

The *Public Utilities Act (PUA)* sets out the structure of the PUB and defines its powers. The PUB has responsibility for the general supervision of public utilities in the Province, which requires the PUB to approve rates, capital expenditures and other aspects of the business of public utilities. NLH is regulated under the *PUA* but its parent, Nalcor is specifically exempted from it. To discharge its *PUA* responsibilities, the PUB has established an annual capital budget review process and procedures for general rate applications. Section 118 provides that the “Act shall be interpreted and construed liberally in order to accomplish its purposes” and “the board created has, in addition to the powers specified in this Act, all additional, implied and incidental powers which may be appropriate or necessary to carry out all the powers specified in this Act.” In sum, the *PUA* and *EPCA* appear to provide the PUB with all necessary authorities to oversee the public utilities it regulates, including overseeing the reasonableness of the rates.

### **Review of Agencies with Oversight over Newfoundland and Labrador Electricity Sector Department of Natural Resources**

The Newfoundland and Labrador Department of Natural Resources (Department) is responsible for the stewardship and development of the province's natural resources. The Department’s Energy Branch has responsibility for legislative, regulatory and policy functions related to the oil and gas and electrical utility sectors. The Department works with Nalcor in policy-related areas for various energy sector activities. Areas of collaboration include issues related to the province’s electricity system and the execution of key policy actions set in the 2007 Energy Plan. The Department also plays an important role in providing the public information on key projects.

### **Board of Commissioners of Public Utilities**

The Board of Commissioners of Public Utilities is an independent, quasi-judicial regulatory body. As is common across Canada, the PUB operates under a policy and regulatory framework established by the government, but with distinct roles and responsibilities. In particular, the PUB’s legislative focus is least cost, whereas the government has a broader public policy focus. Regulation of a Crown utility such as NLH leads to further complexity, since the utility can be an agent for social, economic and environmental objectives in the broader public interest, which are beyond the PUB’s “lowest possible cost consistent with reliable service” focus.

The PUB issues an Annual Report which reviews its mandate and annual performance. This is a best practice.<sup>5</sup> The PUB’s 2013-14 Annual Report indicates that its strategic priorities include enhancing regulatory efficiency and effectiveness and corporate capacity. These priorities are appropriate and reasonable for the PUB. The PUB’s focus on corporate capacity is particularly

---

<sup>5</sup> Best practices are based on Power Advisory’s professional experience and the results of our jurisdictional review.



appropriate for a small jurisdiction, with limited regulatory resources. However, there is evidence that the PUB's regulatory efficiency is an issue.

Given the relatively small size of Newfoundland and Labrador's electricity sector and the corresponding limited resources available to it for this task, the PUB has distinct challenges associated with efficiently and capably regulating the sector. The PUB has sought to address this issue by retaining senior staff and engaging consultants when specialized expertise is required. However, two of the most senior staff members in the regulatory and advisory services section are scheduled to retire. The PUB has focused on expanding and developing staff resources in light of these retirements. This is a critical issue which warrants continued attention given the small staff complement focused on regulatory and advisory services and the PUB's reliance on consultants.

The PUB is also focused on communications with stakeholders, in particular its website as the portal for this communication. Given the volume of information submitted to the PUB and the importance of ready access to this information to stakeholders and their effective participation before the PUB, devoting sufficient resources to the website is critical. Therefore, it is important that the PUB website continue to receive appropriate attention.

Of importance to the regulated community is regulatory predictability and certainty. This is a critical indicator of the quality of regulation. In assessing the performance of the PUB it is useful to evaluate its performance with respect to the oversight and regulation of NP and NLH separately. The PUB's oversight of NP is effective and efficient and results in decisions which generally provide predictability and certainty.

The PUB's experience with NLH is very different. First of all, the PUB has more limited experience regulating NLH given that it only became fully subject to PUB regulatory oversight under the *EPCA* and there have been relatively few GRAs filed by NLH over this time. NLH's business in many ways is more complex than NP's; it is primarily a generation and transmission company, not primarily a distribution company. NLH's 2013 GRA is indicative of the differences with respect to the PUB's oversight. There appear to be inefficiencies evident with respect to the execution of this GRA. For example, over 1,000 information requests were filed and NLH ultimately refiled its application to provide a more current test year.

Another consideration in assessing the performance of the PUB is the fact that a PUB decision was remanded by the Newfoundland and Labrador Court of Appeals (Court) and that a second decision on this very same matter was overturned. Having a decision remanded by the Court is significant, particularly where the Court suggests that the PUB took too narrow a perspective in interpreting its mandate. Furthermore, having a second decision overturned is more problematic. In its decision the Court ruled that the PUB's "decision was unreasonable." This clearly suggests the PUB's decisions with respect to NLH cannot be viewed as being predictable and providing certainty.

The length of time between GRAs and the Court overturning of PUB decisions suggest regulatory inefficiency involving the roles of the PUB, NLH and Government. In sum, there are clearly issues

with respect to the relationship between NLH, the PUB and Government. As a regulated electric utility it is best practice to give greater attention to the regulatory function within the company than is presently the case at NLH. Under the *EPCA* and *PUA*, the PUB has broad powers to provide the required regulatory oversight. With significant government participation in the electricity sector, in some instances the PUB appears to have been reluctant to exercise this discretion. Experience across Canada indicates that the regulator needs to be able to act and operate independently, but this requires that government and stakeholders have confidence in the regulator. This confidence will be enhanced when the knowledge and expertise of the PUB is accepted, making it critical that the PUB attract and retain a qualified staff with deep industry knowledge.

### **Consumer Advocate**

The Consumer Advocate is appointed by the Lieutenant Governor under the *PUA* to represent the interests of domestic and general service customers in the province. All costs of the Consumer Advocate are borne by the PUB and are ultimately paid by customers. The Consumer Advocate represents the interest of customers in each application submitted by electric utilities before the PUB. Currently, the Consumer Advocate is appointed for a standing one-year term to represent the public interest of these customers before the PUB. The existing Consumer Advocate has served in this function since 2004. A majority of Canadian jurisdictions do not have a formal consumer advocate including BC, Saskatchewan, Manitoba, Ontario, New Brunswick and PEI. However, most of these jurisdictions have intervenor funding and organizations which represent small consumer's interests and thereby effectively satisfying the purpose of a consumer advocate.

The presence of the Consumer Advocate in a relatively small jurisdiction such as Newfoundland and Labrador is a best practice. Furthermore, the Consumer Advocate plays an important role before the PUB and has effectively represented domestic and general service customers' interests before the Newfoundland and Labrador Supreme Court, Court of Appeals.

All interveners are able to recover their costs from the utility in whose proceeding they intervene. While this is appropriate for residential and domestic customers who cannot be expected to independently band together to fund an intervention that addresses their interests, it is less so for industrial customers who are better able to assess whether an intervention is likely to be cost-effective. For this reason, in Alberta industrial interveners are often responsible for covering their own intervention costs under the test used by the Commission to determine eligibility for cost recovery. This is a policy that the PUB may wish to consider when determining intervenor funding for interventions.

### **Summary of Governance and Regulatory Best Practices**

The jurisdictional review identified a number of best practices. Those that are relevant to Newfoundland and Labrador are outlined below. The identification of these best practices should not be viewed as indicating that this is necessarily an area of deficiency in Newfoundland and Labrador, only that these are important issues. Furthermore, for some areas the determination of

best practice for Newfoundland and Labrador will be guided by government and stakeholder objectives. In these instances, alternatives are discussed.

### **Governance: Best Practices**

The formal articulation of Government's objectives for Nalcor and NLH can be found in the "strategic directions" reflected in the *Energy Plan*. Government is better able to assess the appropriateness of these strategic directions in light of current objectives for the electricity sector. It is best practice for such strategic directions to be periodically reassessed, particularly after fundamental changes in industry conditions.

To perform their duties effectively Nalcor and NLH board members must have the requisite skills and expertise. It is best practice to appoint board members using a merit-based and objective approach, which ensures that the board as a whole has the necessary skills and qualifications to carry out its functions. Providing directors with a formal Terms of Reference which outlines the province's expectations is also a best practice. It is also best practice to make adequate resources available to board members to enhance their understanding of the electricity sector. This can include formal briefings led by members of the management team on the full range of relevant topics.

*Guidelines for the Governance of the Electricity Sector in Canada* recommends that Board members be appointed for fixed five-year terms to enhance their independence and that the CEO should be appointed by the Board.

### **Regulatory: Best Practices**

Regulators need an explicit standard to guide their decision making. What that appropriate standard is, is a public policy question, best determined by government. However, the degree to which the PUB departs from a narrowly defined public interest test expressed in terms of "least cost", the greater the likelihood that higher costs will be incurred. The *Alberta Energy and Utilities Board Act* is perhaps the most descriptive in defining the public interest for facility reviews as considering the "economic effects of the development, plant, line or pipeline and the effects of the development, plant, line or pipeline on the environment."

Best practice from a regulatory efficiency and outcome perspective is for government to delineate policies to the Crown utility and the regulator clearly and in advance of the specific regulatory proceeding, then leave them to act independently within their mandates.

Best practice is to rely on the regulatory process to assess the need for new facilities and their cost-effectiveness relative to alternatives. However, there may be situations where government wishes to retain the final decision in a matter to itself, rather than defer decision-making to the regulator. This is often the case with respect to oversight of major capital projects such as large new hydro developments. A case can be made that these types of projects require a broader scope for the public interest that recognizes their strategic significance to the Province. Therefore, these are

legitimate decisions for governments to make and it is appropriate for Government to exempt such projects from formal regulatory review.

The capital budget review process conducted by the PUB and its Capital Budget Filing Guidelines are consistent with best practices. However, the \$50,000 capital expenditure and \$5,000 capital lease threshold are much too low. As discussed above, expanding the scope of the capital budgeting process to more broadly consider resource planning issues may also be appropriate. Experience elsewhere indicates that consultative resource planning processes enhance public confidence in investment decisions and aligns stakeholder views.

NLH is a regulated electric utility, with regulatory oversight provided by the PUB who has responsibility for overseeing rates, and reviewing NLH's capital expenditures. The regulatory function in NLH doesn't appear to be given the prominence that reflects best practice. It is common with many other regulated utilities to have an officer responsible for the regulatory function.

Customers on the 21 isolated systems in Newfoundland and Labrador and in rural areas in Newfoundland receive a subsidy that is funded by Newfoundland Power and Labrador Interconnected System domestic and general service customers. With this subsidy paid only by domestic and general service customers it represents a significant portion (about 8%) of NP customers' total electricity costs. Given the cost impact on these customers, a case can be made that a lower subsidy for a lifeline block would send customers receiving the subsidy a better price signal to reflect the high cost of serving them so that they use this energy efficiently and aggressively pursue energy efficiency alternatives.

Prior to its July 2013 GRA filing, NLH's previous GRA was in 2007. Waiting six years between GRA filings cannot be viewed as best practice even with an annual capital budget process and a Rate Stabilization Plan that accommodates changes in fuel prices for Holyrood and the impacts of changes of load and hydro output on Holyrood's fuel requirements. Nonetheless, Power Advisory understands that there were a series of events and outcomes, which contributed to the length of time between GRAs. A second aspect to the timeliness of the rate review process is that of the regulator in reviewing the GRA. The conduct of the regulator has a bearing on the pace at which the rate review proceeds. Best practice is to establish an issues list early in the proceeding and to ensure the list is used to guide the scope of the case. It is also best practice that there be a requirement or a formal goal that decisions be issued within a set period from when the record is closed, e.g., within 90 days.

### **Commercial: Best Practices**

A best practice is recognizing the importance associated with active participation in export markets and developing a strategy for doing so that is well suited to the province's electricity resources and objectives. In Nalcor's case this would include considering the resource portfolio, energy and capacity available for export, tax considerations, and market access alternatives.

Having an Open Access Transmission Tariff or a tariff that provides a comparable level of service is a best practice. A key related decision for NLH or a Nalcor affiliate is which form of transmission service it will offer once Newfoundland and Labrador is interconnected with the rest of the North American electricity grid. Specifically, the choices are to implement: (1) an OATT patterned after the FERC pro forma tariff; or (2) a transmission tariff which provides virtually comparable level of service, but differs from the FERC pro forma tariff. The final implementation question to be addressed is what process will be available for hearing any disputes that may arise from the administration of the tariff. In most Canadian provinces (all except Manitoba and Saskatchewan, which does not have a formal regulator) disputes are heard by the provincial regulator. This is best practice.

Another related decision for Newfoundland and Labrador is to determine where the system operator functions will reside. Options include: (1) have functions reside within NLH, but with functional separation consistent with the framework outlined by FERC Order 889;<sup>6</sup> or (2) create a separate entity to provide these services. Clearly, the first option is the easiest and the lowest cost. The second option is progressively more complicated and costly. Functional separation of these functions at a minimum is best practice where multiple parties will avail themselves of the transmission facilities.

In many jurisdictions regulators have authority to approve long-term contracts. This is important where the risks associated with such contracts ultimately are borne or shared with ratepayers. Where these risks reside with the utility there is no need for the regulator to oversee or approve such contracts. Government may desire that any oversight regarding such contracts reside with it, as shareholder.

BC and Québec have opted for heritage pools or contracts to ensure the benefits of low cost energy from their hydroelectric facilities to customers. If Newfoundland and Labrador were to implement a Heritage Pool a number of decisions would need to be made regarding its structure. The two most fundamental are the: (1) assets to be covered; and (2) framework that would be used to establish the Heritage rate over time. The most obvious facilities to be included in the Heritage Pool in Newfoundland and Labrador are NLH's existing hydro facilities.

The PUB could be given authority to establish the Heritage rate (e.g., as in BC) or the Heritage rate could be prescribed by Government (e.g., as in Québec). Having the PUB establish the Heritage rate enhances transparency, but can increase administrative complexity. Alternatively, the Heritage rate can be set by government based on an assessment of what is the appropriate return to be earned and the underlying cost of providing the service.

In Newfoundland and Labrador similar to Nova Scotia, utilities incentives to aggressively pursue energy efficiency programs are muted by ratemaking practice, whereby fixed costs are recovered in

---

<sup>6</sup> FERC Order 889 clearly doesn't apply to NLH, but it does represent an operating construct that has been widely implemented.

energy charges such that reductions in load can result in reduced cost recovery and lower net income. Therefore, having an independent organization pursue such programs may be beneficial. However, this typically comes with an additional cost as reflected by the overheads associated with this organization.

### **Electric Power System Fundamentals**

All businesses plan, invest and ensure operational readiness to serve their customers. These basics are also applicable to the electricity industry, but given the safety, environmental impacts, need for high reliability, cost, technical complexity and major project lead times inherent in the industry, each of these basic business practices requires detailed and carefully developed plans and operating procedures. Having satisfied safety and environmental requirements, reliability of service and cost of supply become a power system's key measures of success.

Electricity customers evaluate the reliability of a power system by the extent to which it supplies power to them in accordance with their requirements, i.e. sufficient amounts of power are available when they wish to use it within the committed quality parameters such as voltage level. Many factors and processes affect the ability of power system operators to supply power to electricity consumers at these expected reliability levels. These include the ability to forecast customer requirements accurately far enough in advance; plan how to best meet these requirements allowing for unexpected events; timely place into service the new facilities identified in the plan, adequately maintain all assets, and operate the assets safely under the full range of system conditions. Finally, this must all be done at a cost that is not inconsistent with the willingness of electricity consumers to pay for the reliability that they desire. This is illustrated schematically in Figure ES-2. Problems or shortcomings in any one of these elements, or a combination of issues, can result in reliability levels that do not meet customer requirements or result in unacceptable costs.

**Figure ES-2: Factors in Meeting Customer Requirements**

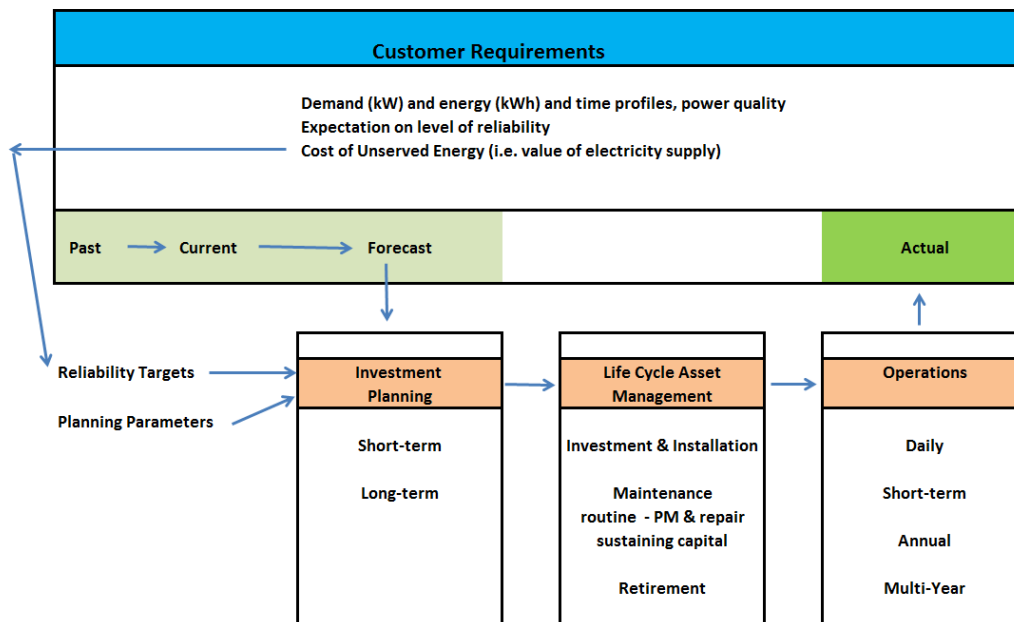

Source: Hatch

### Electric Power Systems - Isolated and Interconnected

Electric power systems can be connected to each other in various ways. As discussed above, Newfoundland and Labrador is largely isolated from the North American grid and has 21 remote, isolated systems. When a power system is electrically isolated decisions on investment and operation have a direct impact only on its own customers and stakeholders. Once safety and environmental requirements are met, choices can be made independently by balancing reliability and cost of service objectives. On the other hand, the system is wholly dependent on its own resources and if in the short-term these resources cannot meet customer requirements this will result in some or all customers losing service for a period of time. Once a power system is interconnected to one or more neighbouring systems these systems can often provide resources to it when needed and synergies from joint operation can be realized. However, there is also a responsibility to ensure that operation of a power system does not jeopardize the performance of the system or systems to which it is interconnected.

The IIS has been electrically isolated and decisions on planning and investment have reflected this. As it transitions to an interconnected system it will be less costly to provide a higher level of reliability than in the past and there will also be options to export electricity that is not needed in Newfoundland and Labrador. But there will also be changes that are necessary, or desirable, to operate the Newfoundland and Labrador system as part of the broader North American power system.

## **Electric Industry Reliability Organizations**

The current framework for reliability of the bulk power system in North America has its origins in the Northeast blackout of 1966. Several years after that, the National Electric Reliability Council was formed to set reliability standards and criteria and this became the North American Reliability Corporation (NERC) when electric utilities in Canada and Mexico joined the various regional reliability councils. Following the Northeast Blackout of 2003, the US government passed the 2005 *Energy Policy Act* which included provision for mandatory compliance of reliability standards to be developed by an agency subject to US Federal Energy Regulatory Commission (FERC) jurisdiction. Also in 2005 a document entitled “*Principles for an Electric Reliability Organization that can Function on an International Basis*” was developed by the joint Canada-US Bilateral Electric Reliability Oversight Group and agreed to by the US and Canadian federal governments and various Canadian provinces and territories. NERC was tasked with responsibility for enforcing compliance with reliability standards. While NERC does not have jurisdiction in Canada, most provinces have either adopted or are in the process of adopting all or some of the NERC reliability standards. The NERC reliability standards have essentially become the industry standard for utilities to follow to achieve reliable operation of their power grids.

There are also Regional Reliability Organizations (RRO) across North America that work in coordination with NERC to ensure the reliability of the power grid by region. They are responsible for the compliance monitoring and enforcement of the reliability standards for their region. The RRO responsible for the northeastern region of North America (adjacent to Newfoundland and Labrador) is the Northeast Power Coordinating Council (NPCC).

As part of its preparation for further interconnection of Newfoundland and Labrador with the North American electric power system and participation in export markets, NLH has been assessing the NERC reliability standards and NPCC reliability criteria for applicability to its system. NLH intends to adopt those that are relevant to its system and to obtain membership in these organizations. This is considered a best practice as the standards and criteria have been developed by the industry and participation will ensure consistency with other jurisdictions in North America. The most recent study on this subject conducted for NLH in April 2015 indicates that significant additional work is needed to identify gaps and that the costs of attaining and maintaining compliance with these standards and criteria will be material.

## **Electric Power System Reliability Criteria**

The focus of the reliability organizations described above is to prevent operational issues in one power system from causing cascading events that have material impacts on the interconnected power systems. Standing behind this, are the reliability targets that are established by individual power utilities to ensure that they provide reliable service to their customers. The principle is that investing in higher levels of redundancy allows a system to maintain service even when equipment fails or when large load variations take place due to extreme weather. However, given that these investments increase costs to customers, at some point the incremental cost can exceed what the



service improvement is worth to the customers. In theory the amount a power system spends to ensure reliability should not exceed what its customers are willing to pay for, but such assessments are complex and different customers value reliability differently. Over time most electric power systems in North America have established the Loss of Load Probability (LOLP) criterion as the measure of reliability (adequacy) for their generation systems. Most North American electric utilities have established an LOLP target level of 0.1 day per year.

NLH determined that without connections to other power systems that could provide support when it was short of generation it would be too expensive to adopt the industry standard of an LOLP target of 0.1 day per year. NLH is planning to reevaluate its generation planning reliability criterion once it is interconnected to the Nova Scotia system and currently expects to adopt the equivalent of the best practice level of an LOLP target of 0.1 day per year.

NLH has established a set of transmission planning criteria for its bulk transmission system and a less stringent set for its radial systems. These criteria are the basis for assessing the adequacy of its existing systems and establish future reinforcement or expansion requirements. The criteria for its bulk transmission system include a requirement that the system be capable of sustaining an outage of any one transmission element (single contingency). However, on an overall basis NLH's bulk transmission system criteria do not adhere to NERC reliability standards. For instance load shedding is allowed in the event of the loss of a larger generator given the cost associated with having the system robust enough to serve full load under these conditions. NLH is planning to make its criteria more stringent after the Labrador-Island Link and Maritime Link are in service. However, it is also understood that there may still be some elements that do not fully meet utility best practices.

NP is the primary provider of distribution services on the Island with NLH having responsibility for distribution in Labrador. The distribution system capacity planning criteria used by both organizations are consistent with best practice for the industry.

### **Reliability of Service**

The reliability of electricity service in the province is a major element of our review. A range of different measures of service reliability are employed. From a customer-perspective the most meaningful indices are those that measure the service reliability that they experience. The average outage duration indicates the amount of time that a customer is without service. Given that it provides service to customers in the more remote areas of the province, NLH typically has higher total outage durations than other Canadian electric utilities including NP. Whereas, NP typically has lower outage durations than other Canadian electric utilities. NP statistics indicate that the largest contributor to outages for its system in the last two years was NLH system supply. Over the last ten years NP's system has generally experienced a decline in outages when loss of supply is excluded, whereas for NLH system outages have been increasing which appears to be attributable in part to an increase in extreme weather.

## **Energy Efficiency Programs**

NLH and NP have worked together to develop and offer programs to assist electricity consumers use electricity more efficiently. However, the impacts of these programs on electricity consumption to date have been quite modest relative to those achieved by some other Canadian electric utilities. Specifically, available information suggests a 1% saving as of 2012 in NL versus up to 5% energy efficiency savings claimed by Ontario and Nova Scotia.

The Newfoundland and Labrador electric power system records its highest loads during the winter months. In 2014 the IIS peak demand recorded in February was close to 900 MW higher than the monthly peak load levels of about 800 MW in July and August. The pattern is similar for the LIS; winter peak load of close to 400 MW and summer peak load of just over 200 MW. The principal reasons for the doubling of the system peak load in the winter months are residential electric space heating which is estimated to have a penetration rate of some 85% and lighting. A more aggressive effort to increase energy efficiency could focus on policies, programs and incentives that would be applicable to these end uses of electricity. NLH and NP are conducting a study to evaluate various energy efficiency and demand side management programs for the NL electricity systems. This is timely and the findings should help in developing new cost-effective programs that benefit customers.

## **Load Forecasting**

Load forecasting plays an important role throughout the planning and operating functions of NLH and NP. NLH has three durations of load forecasts: (1) a short-term forecast, which looks out over the next seven days and is used for operational purposes; (2) a medium-term forecast, which has a five-year horizon and is used for budgeting and medium-term operational planning (e.g., outage scheduling and hydro-thermal optimization); and (3) a long-term forecast with a twenty-year horizon, which is used primarily for investment analysis and planning. Our review of the procedures used for each of the forecast durations noted a continuous improvement approach which represents best practice. The future load growth for residential electric space heating is of critical importance.

## **Investment Planning**

Electric utilities conduct both short and long-term investment planning. The short-term planning relates to the annual capital budgeting process and the long-term planning can be generation planning, transmission planning or integrated resource planning (IRP) in which a preferred overall plan is identified taking into account the full range of generation, transmission and in some cases distribution factors. Under the legislation governing the provincial electricity sector (in particular, the *EPCA*) the PUB has jurisdiction over the planning for both of these time dimensions.

Both NLH and NP carry out robust internal planning that is consistent with utility best practices. NLH does not prepare and distribute for stakeholder review and comment a comprehensive plan for the long-term development of the Newfoundland and Labrador electric power system. Such plans, sometimes called integrated resource plans, are required by regulators or governments in several Canadian jurisdictions and are often subjected to some level of stakeholder scrutiny. Such plans were at one time regarded as best practice for the electric utility industry, but are considered to be inconsistent with competitive electricity market structures, where market forces drive the development of new generation. While generation investment in Newfoundland and Labrador isn't market-based, with the development of Muskrat Falls there will be no need for additional generation for a number of years. Nevertheless development and stakeholder review of such a plan could be beneficial longer term so as to provide stakeholders confidence that the power system investments being made are best meeting the needs of the province as a whole.

### **Asset Management**

Broadly speaking, asset management encompasses the procedures, programs and processes used to care for each utility asset over its lifecycle. This includes the design, implementation and commissioning activities to bring the asset into service, the routine operation and maintenance of the asset during its operating life, sustaining capital investments and ultimately the de-commissioning and removal of the asset. The period of years during which an asset can operate cost effectively and reliably is directly related to the effectiveness of the asset management program during each stage of its life. As assets age, the cost of keeping them operating efficiently typically increases as does the likelihood of operating problems that reduce reliability. Tradeoffs need to be considered between the cost of maintaining an asset and the cost of replacing it with a new asset. Both NLH and NP have detailed asset management programs that incorporate continuous improvement programs and the overall methods followed by both utilities meet utility industry best practices.

Given the sharp increase in the loads served by the power system during the winter months, it is absolutely critical that major maintenance activities are scheduled for the months when the system experiences low load and that schedules are maintained so that all major generating and transmission facilities are available when the high load period begins. NLH has taken effective steps over the last year to make sure this is the case going forward.

### **System Operations**

In essence, system operations involves meeting the changing requirements of electricity customers reliably utilizing the combination of available generation and power delivery resources to provide service safely and cost effectively. The forecasting, investment planning and asset management activities described in previous sections are focused on allowing system operations to constantly satisfy customer requirements.

In addition to increasing generation capability through the commissioning of the 123.5 MW combustion turbine at Holyrood in early 2015, NLH has taken steps to increase the load it can control through demand response. The Energy Control Centre is now able to dispatch off up to 105.8 MW of load under the provisions of NLH agreements with various customers. While this is a relatively small amount in absolute terms (about 7% of system peak load), it could be very significant under certain system conditions. This approach with large industrial customers is considered a best practice and appropriate given the generation resource constraints that the system has been facing (and is expected to prevail until Muskrat Falls and the Labrador-Island Link are in service). Furthermore, demand response provides a low cost source of reserves even when there aren't impeding capacity resource constraints. Other utilities that face steep weather-driven peak loads have provided incentives to smaller customers to allow their weather dependent loads (such as electric heating) to cycle off for short periods of time under critical system conditions. Given the importance of electric heating to NLH's system peak, such a program may be attractive.

# 1. Introduction

In January 2014 the Government of Newfoundland and Labrador announced an independent review “to look at the current electricity system in Newfoundland and Labrador – how it operates, is managed and regulated as the province moves from an isolated system to an interconnected system.” To initiate this review process the Newfoundland and Labrador Department of Natural Resources (Department) issued a Request for Proposals (RFP) to seek consulting expertise to “undertake a review and analysis of the legislation, regulation, management and operation of the Newfoundland and Labrador electricity system.” Power Advisory LLC (Power Advisory) was engaged by the Department to undertake this review.<sup>7</sup>

## 1.1 Scope of Review and This Report

This report presents the findings from Power Advisory and Hatch Ltd’s review. We first provide an overview of Newfoundland and Labrador’s electricity system. This overview provides an inventory and review of the performance of Newfoundland and Labrador’s electricity system and reviews various stakeholder roles and responsibilities in relation to planning, management, regulation, and operations of the provincial electricity system.

After this, we review the governance, legislation and regulation of Newfoundland and Labrador’s electricity sector. This review draws upon the experience in other Canadian provinces focusing on the: (1) structure of their electricity sector; (2) enabling legislation; (3) the roles, responsibilities, and practices of key electricity sector institutions; and (4) various reforms to the electricity sector to enhance effectiveness and achieve efficiencies. The report then reviews system reliability, operations, performance and accountability and draws comparisons with best practices used in other jurisdictions.

The ultimate objective is to identify best practices for Newfoundland and Labrador’s electricity sector to ensure that (1) it promotes the appropriate balance between reliability and affordability; (2) it enables Newfoundland and Labrador to maximize value over the long term from electricity available for export; and (3) the regulatory process is appropriately streamlined, yet contains sufficient protections to ensure that rates paid by customers are just and reasonable and promote reliable service.

Power Advisory has sought to minimize duplication with a review being conducted by the Newfoundland and Labrador Board of Commissioners of Public Utilities (PUB) into the reasons for the January 2014 power outages and appropriate solutions to avoid such outages in the future.<sup>8</sup>

---

<sup>7</sup> Power Advisory partnered with Hatch Ltd. (Hatch) to provide this review. In general, Power Advisory had primary responsibility for the overview of the provincial electricity sector and the governance, legislative and regulatory review (Chapters 2-6). Hatch had primary responsibility with respect to the review of system reliability and operations (Chapters 7-11).

<sup>8</sup> In its Interim Report on Supply Issues and Power Outages Review: Island Interconnected System (Interim Report), Liberty Consulting Group (Liberty), the PUB’s consultant, noted that “coming work will address matters with long-

### **1.1.1 Role of Consulting Team**

As consultants to government, Power Advisory was asked to identify best practices that could be employed by Newfoundland and Labrador to enhance the performance of its electricity sector. It is ultimately up to government to determine which of these best practices are most appropriate for the province. This requires weighing various policy considerations and objectives and making decisions that it is not appropriate for a consultant to make. Therefore, we don't offer recommendations in this report.

### **1.2 Approach Followed in Preparing this Report**

To prepare this report Power Advisory relied on the data request responses from Newfoundland and Labrador Hydro (NLH) and Newfoundland Power (NP); had face-to-face meetings with the utilities, the PUB staff, and the Consumer Advocate; had follow-up phone calls with these parties on specific issues; conducted a review of the electricity sectors in other Canadian provinces to identify best practices; and conducted phone interviews with individuals from different Provinces.

### **1.3 Contents of Report**

This report contains eleven chapters within what are three separate Parts. Part 1 provides an overview of Newfoundland and Labrador's electricity sector and serves as an introduction. Part 2 reviews the governance, legislation, and regulation of Newfoundland and Labrador's electricity sector and the third reviews system reliability, operations, performance and accountability and draws comparisons with best practices employed in other jurisdictions.

In Part 1, the first chapter is this introduction and reviews the overall scope of the project and of this report. Chapter 2 provides a general overview of the Newfoundland and Labrador electricity system and the electric utilities and companies that participate in it. The third chapter reviews relevant electricity sector legislation, agencies with oversight over the electricity sector, and major changes to the sector in the last twenty years.

Part 2 contains Chapters 4 through 6. The fourth chapter reviews other Canadian provinces' electricity sectors and provides the foundation for many of the best practices reviewed later in Chapter 6. The fifth chapter assesses the performance of the agencies with oversight over the electricity sector including the PUB and Consumer Advocate. Chapter 6 identifies governance and regulatory best practices drawing upon the discussion in Chapter 4 and experience elsewhere.

Part 3 contains Chapters 7 through 11. Chapter 7 reviews system reliability; Chapter 8 assesses load forecasting and Chapter 9 reviews investment planning. Chapter 10 reviews asset management and Chapter 11 reviews system operations.

Finally, high level conclusions are presented in Chapter 12.

---

term reliability implications. In particular, the reliability implications of Hydro's system after Muskrat Falls enters service will form a major focus of our coming review. Hydro's structure and organization will as well." (p. 13).

Appendix A is a glossary of key industry terms and Appendix B reviews the relevant statistics for the generation assets in the province. Appendix C provides the electricity demand and load summary statistics for the various systems in the province. Appendix D presents the reliability metrics for Newfoundland Labrador Hydro and Newfoundland Power. Appendix E reviews the derivation of Loss of Load Probability versus Loss of Load Hours calculations; Appendix F reviews how reliability impacts can be considered when assessing system costs; and Appendix G reviews how various reliability metrics are calculated. Finally, Appendix H reviews NLH calculations regarding the cost of maintaining additional generation reserves.

## **2. Overview of Newfoundland and Labrador Electricity Sector**

This chapter provides an overview of the Newfoundland and Labrador electricity sector. It is organized in six sections. The first provides a broad sector overview. The second section reviews the province's electricity systems including the Island Interconnected System (IIS), the Labrador Interconnected System (LIS), and the various isolated systems. The next section describes the key electricity sector service providers including the two electric utilities, key affiliates, and various other entities that provide electricity in the province. For each utility, a summary of generation assets, historical energy requirements, and customer information is provided. In the fourth section the Muskrat Falls hydroelectric project and the commercial arrangements associated with the project are reviewed. The chapter then reviews forecasts of the future energy requirements for the IIS, the LIS, and the Newfoundland and Labrador Combined Interconnected System. The penultimate section reviews electricity rates in the province. The final section is a summary.

### **2.1 Broad Overview of Sector**

The Newfoundland and Labrador electricity system has nearly 7,500 MW of electrical generating capacity and serves approximately 290,000 customers. This generating capacity includes hydroelectric, residual oil-fired, wind, biomass and diesel generation. The province's electricity customers are connected to the IIS, the LIS, or to one of 21 isolated diesel systems located in coastal communities.

Among the province's hydroelectric generating stations is the Churchill Falls generating facility, which has a rated capacity of 5,428 MW. A significant portion of the electricity produced by Churchill Falls is sold to Hydro-Québec under a long-term contract, with the balance available to customers in Labrador and for export.<sup>9</sup> With no transmission connection between Labrador and Newfoundland, any surpluses in Labrador currently cannot be made available to Newfoundland. However, with the development of the Muskrat Falls project, the Labrador Transmission Assets, which will connect Muskrat Falls and Churchill Falls, and the Labrador-Island Link, which will connect Labrador and Newfoundland, energy and capacity in Labrador will be able to be used to serve customers on the Island of Newfoundland (Island).

Electricity supply and distribution service in the province is primarily provided by two utilities: Newfoundland and Labrador Hydro (NLH, a subsidiary of Nalcor Energy) and Newfoundland Power (NP). NP is primarily an electricity delivery and customer service organization and serves customers exclusively on the Island, while NLH is primarily an electricity generation and transmission organization. NLH operates the larger generation projects and high voltage transmission systems. NP, owned by Fortis Inc., a publicly traded company, is the distributor serving the vast majority of customers on the Island. NP purchases the majority of its power from NLH, but generates a portion of its customers' requirements from facilities that it owns. In Labrador, NLH undertakes generation, transmission and distribution of electricity. NLH also

---

<sup>9</sup> This includes energy from the former Twinco Block 225 MW and 300 MW from the Recall Block.



distributes power to rural customers on the Island. Utilities in the province are regulated by the Newfoundland and Labrador Board of Commissioners of Public Utilities (PUB). *The Electrical Power Control Act 1994 (EPCA)*, which regulates the electrical power resources of the province, sets policy regarding electrical power rates and establishes provisions for the determination of those rates by the PUB.

In addition to NLH and NP, there are other entities within the province that provide generation and transmission service. These include Churchill Falls (Labrador) Corporation Limited (CFLCo), which owns and operates the Churchill Falls project and associated transmission facilities that interconnect the project to the Québec transmission system. In addition, there are various non-utility generators (NUGs) on the IIS that provide energy and capacity to NLH under long-term power purchase agreements including two 27 MW wind farms and the Rattle Brook hydroelectric project. Corner Brook Pulp and Paper owns hydroelectric generation which provides power to its mill and makes surplus energy available to NLH and a biomass project which has a long-term power purchase agreement with NLH. Finally, the Province owns the Exploits hydroelectric generating stations, which were formerly owned by AbitibiBowater.

## **2.2 Electricity System Composition**

The province's electricity system is composed of: (1) IIS, which serves Newfoundland; (2) LIS, which serves Labrador; and (3) 21 isolated diesel systems in coastal communities throughout the province. A description of these systems is provided in the following sections.

### **2.2.1 Island Interconnected System**

The majority of customers within Newfoundland and Labrador are served by the IIS which has approximately 2,010 MW of net generating capacity. This system encompasses the main transmission grid on the Island and is physically isolated from Labrador and the North American grid. While the majority of electricity consumers and load are located in the eastern region of the Island (i.e. the Avalon Peninsula), the majority of IIS generation is located in western and central regions with the exception of the 490 MW Holyrood oil steam generating station,<sup>10</sup> the Hardwoods Gas Turbine (50 MW), a new 123.5 MW gas turbine located at Holyrood, the Fermeuse Wind Project (27 MW), and various NP small generating plants, which are primarily hydroelectric.

NLH owns and operates generating stations which provide approximately 80% of the total electrical power consumed by customers connected to the IIS. NLH generation assets serving the IIS include nine hydroelectric plants (954.4 MW),<sup>11</sup> the Holyrood Thermal Generating Station, three combustion turbines (223.5 MW), and two diesel plants (24.7 MW).<sup>12</sup> Additionally, NLH also

---

<sup>10</sup> The Holyrood generating station has a gross continuous capacity rating of 490 MW, but net capacity rating (excluding station service) of 465.5 MW.

<sup>11</sup> Included within the 954.4 MW is the capacity offered by Bay d'Espoir, Hinds Lake, Upper Salmon, Cat Arm, Granite Canal, Snooks Arm, Venams Bight, Roddickton, and Paradise River hydroelectric units.

<sup>12</sup> Newfoundland Power also owns various hydroelectric generating units, gas turbines and diesels which are embedded in its distribution system and provide 138.4 MW.

purchases power from various non-utility generators, including two wind farms offering 54 MW, a 15 MW biomass unit at Corner Brook Pulp and Paper, and Rattle Brook, a 4 MW hydroelectric unit. Deer Lake Power, which is owned by Corner Brook Pulp and Paper Limited, provides 135 MW<sup>13</sup> and Exploits, currently owned by the Province of Newfoundland and Labrador, offers up to 95.6 MW. In addition, NLH has a capacity assistance agreement with Vale which provides 11 MW. NLH recently installed a combustion turbine with an installed capacity of 123.5 MW to meet system supply adequacy between 2015 and 2017/18 when the Labrador-Island Link is scheduled to be energized. NLH synchronized the combustion turbine to the Island grid on January 21, 2015.

Table 1 below summarizes the generation supply on the IIS.

**Table 1: Island Interconnected System Supply (MW)**

<b>Island Interconnected Supply</b>		<b>Gross Continuous Unit Rating</b>	<b>Additional Capacity</b>	<b>Total Capacity</b>
<b>NLH System</b>				
NLH Owned	Hydro	954.4	4.4	958.8
	Holyrood	490		490
	Gas Turbine	223.5		223.5
	Diesel	24.7	4.6	29.3
	Total Owned	1,692.6	9	1,701.6
Purchased	Hydro	81	38.5	119.5
	Co-generation	8	7	15
	Wind	0	54	54
	Total Purchased	89	99.5	188.5
Total NLH System		1,781.6	108.5	1,890.1

<sup>13</sup> Some of this generation is only available at 50 Hz so it cannot all be made available to the IIS.

<b>Newfoundland Power</b>				
Newfoundland Power	Hydro	76.5	19.8	96.2
	Gas Turbine	36.5		36.5
	Diesel	5.0		5
Total Newfoundland Power		117.9	19.8	137.7
<b>Customer Owned</b>				
Corner Brook Pulp and Paper	Hydro	99.1		99.1
Vale Capacity Assistance	Diesel	11.0		11
Total Customer Owned		110.1		110.1
<b>Total Island Interconnected</b>		<b>2,009.6</b>	<b>128.3</b>	<b>2,137.9</b>

Excludes Corner Brook Pulp & Paper Interruptible Contract and various other interruptible resources

Source: NLH December 18, 2014 Email

### **2.2.1.1 IIS Load**

Figures 1 and 2 show the load characteristics and the annual energy requirements for the IIS. Initially, information is provided on the load curves for the peak and low load days, monthly peak and energy demands and the annual load duration curve and then historical energy and peak loads are presented.

In 2014 the peak load day occurred on February 10 and the low load day occurred on September 23.<sup>14</sup> The hourly load curves for these days are presented in Figure 1.

<sup>14</sup> Customer interruptions in early January 2014 may have obscured a peak during this period.

**Figure 1: IIS Hourly Load: Peak and Low Load Days**

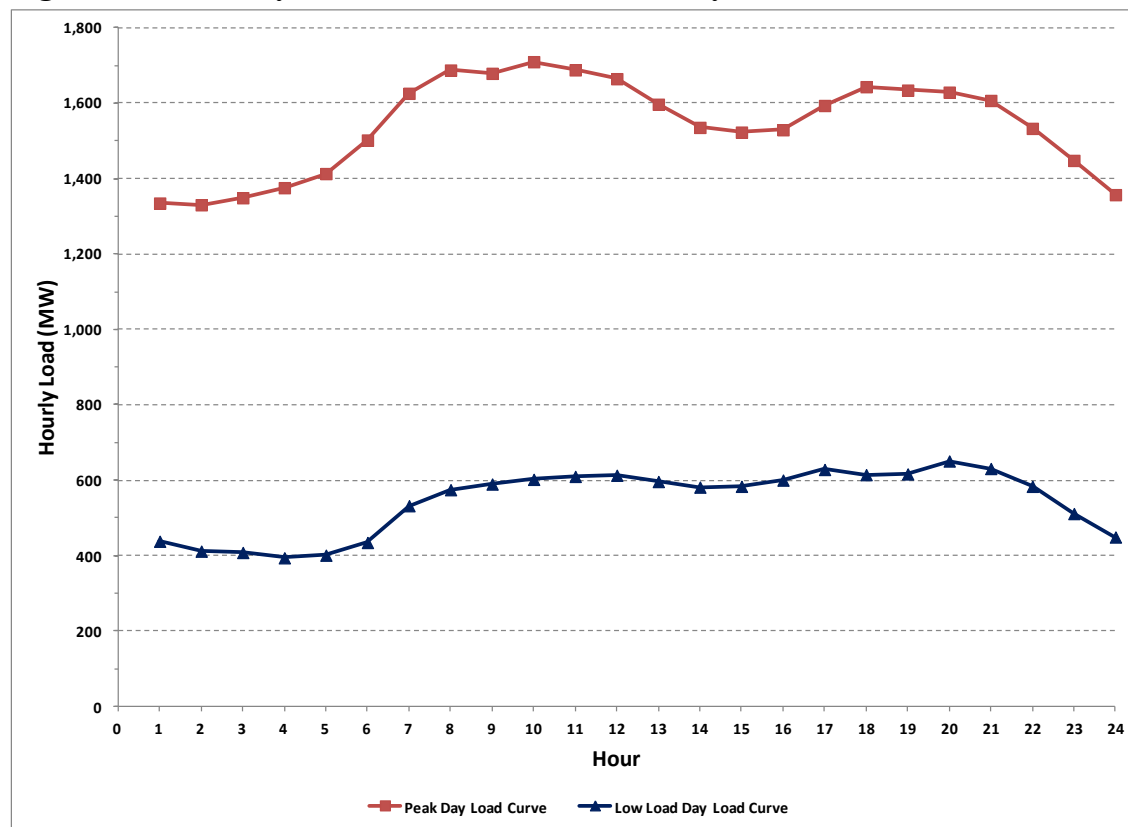

Source: NLH

On the peak day the system had dual peaks, one occurred from Hour 7 to Hour 13 in the morning and early afternoon and the other from Hour 17 to Hour 21 in the evening. The morning peak at approximately 1,700 MW was higher than the evening peak. The load variation within the day was approximately 380 MW. On many peak load days the evening peak demand is higher than morning-afternoon peak demand. While in 2014 the highest load day was in February, the annual peak day can occur on any day during the period December to March, depending largely on extreme weather conditions. A lower load during the evening peak than during the morning peak may reflect the longer daylight hours in February relative to December or January.

The load on the low load day was relatively flat, which was around or slightly over 600 MW from Hour 9 to Hour 22. The load variation within the day was approximately 200 MW, with the minimum load over the early morning hours about 400 MW.

Figure 2 presents the monthly peak and energy demands. As noted above, the 2014 annual peak occurred in February and the system had the lowest peak demand in the two summer months, of July and August. In those months the highest demand was in the 800 MW range. The energy demand was highest in January and March and the lowest in the July-September period. Even though February had the day with the highest power demand, the energy requirement over that month was lower than in January and March at least partly due to the fact that February had 28 days as opposed to 31 days in January and March.

**Figure 2: IIS Monthly Peak and Energy Requirements**

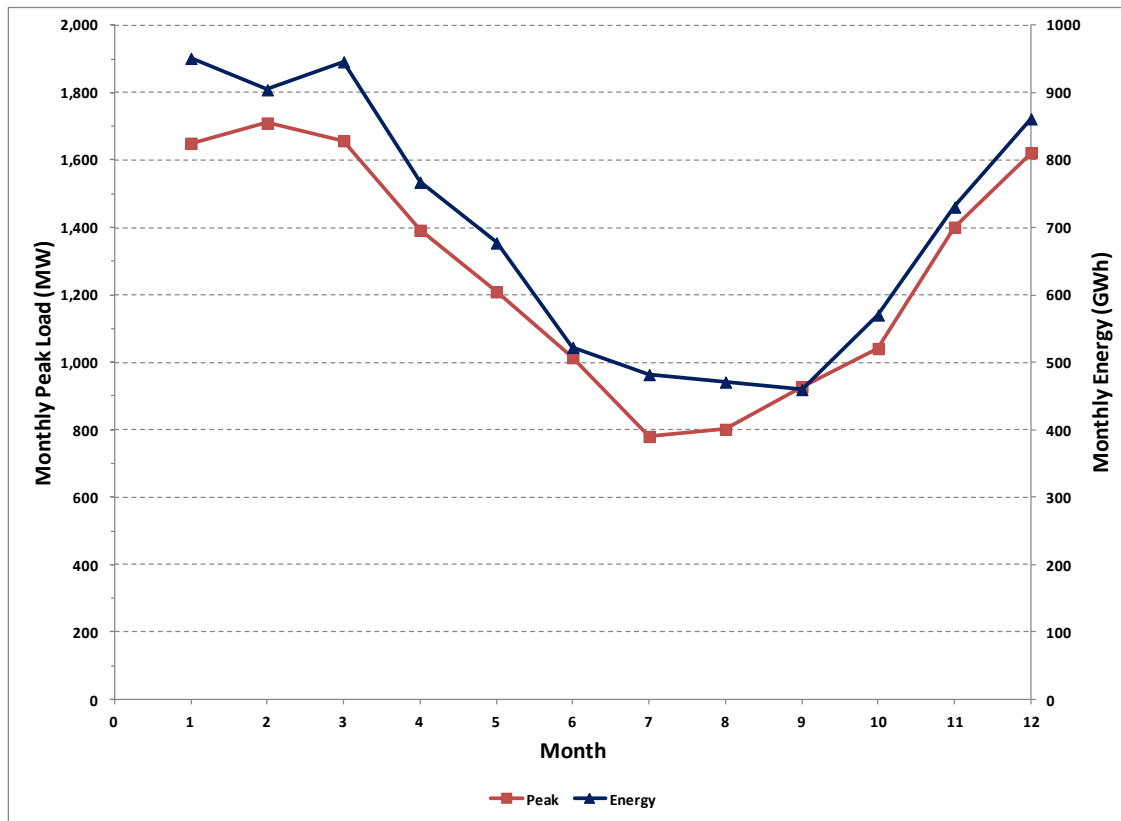

Source: NLH

Figure 3 shows the system hourly load duration curve in 2014. It could be seen from this figure that the annual peak was approximately 1,700 MW and there was a load level over 1,400 MW for only about 7% of the time during the year. For the load curve below 1,400 MW, it could be represented by several straight line segments. The lowest load in the year was only about 400 MW, which is less than 25% of the annual peak. Approximately 40% of the time the load was under 800 MW but there was only about 2% of time with a load level less than 500 MW. Supply of a power system’s peak loads is a challenge that is typically brought to the attention of all stakeholders through public notices encouraging energy conservation, but in some cases balancing supply and demand at times of very low load can be just as challenging for the system operator. In addition to electrical system challenges of maintaining power quality at low loads, with the significant hydroelectric resources available to the IIS very low loads can result in spilling water and the resulting loss of the energy production capability of this water.

**Figure 3: IIS Annual Load Duration Curve: 2014**

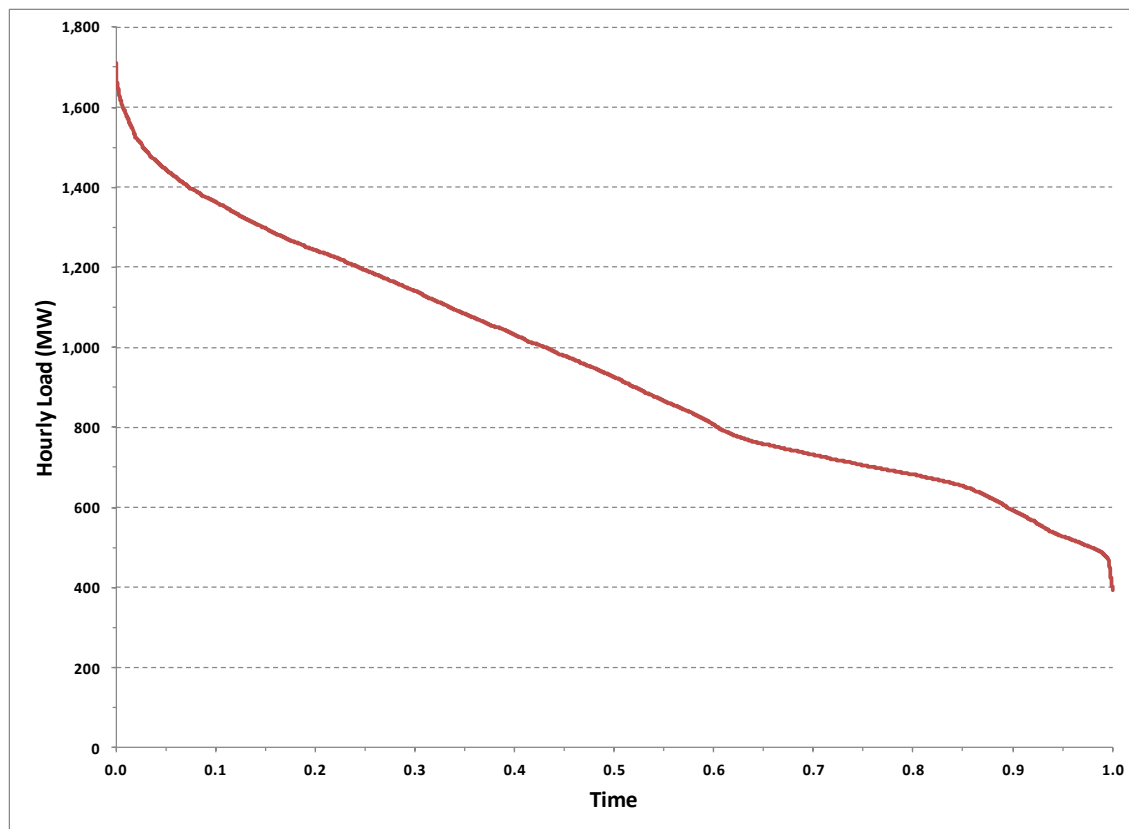

Source: NLH

Industrial customer load on the IIS has decreased significantly since 2003 with an annual decrease from 2003 to 2013 of 7.5%. The primary contributor to this decrease in industrial customer load has been the closure of newsprint mills in Stephenville and Grand Falls-Windsor as well as reduced paper production at the Corner Brook mill, resulting in a total reduction in industrial average demand of approximately 182 MW since 2004.<sup>15</sup> This decline in industrial load has been offset by increases in residential and commercial load. Since 2002, Island residential and commercial demand has increased by 17%. Over the same period, approximately 28,800 new homes were constructed with 85% of them using electric heat.<sup>16</sup> While industrial demand has fluctuated reflecting the referenced newsprint mill shutdowns in 2006 and 2009, the underlying growth in residential and commercial demand has sustained electricity demand. Future growth is forecast from the nickel processing facility in Long Harbour, which entered commercial operation in 2013. NLH's 2013 amended GRA indicates that the average monthly load for this facility is likely to be 77.6 MW in 2017.

<sup>15</sup> Department of Natural Resources, *Electricity Demand Forecast: Do We Need the Power?*, November, 2012, p. 5.

<sup>16</sup> The high proportion of new residential construction using electric heat is atypical relative to most other North American jurisdictions and reflects the more limited heating options available in Newfoundland and Labrador, particularly in remote areas. This underscores the importance associated with the thermal efficiency of these dwellings.

**Figure 4: Annual Energy Requirements for Island Interconnected System (GWh)**

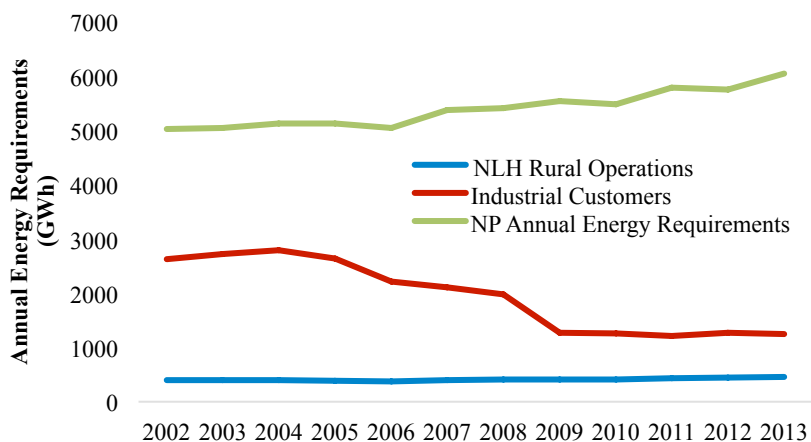

Source: NLH

The total island system energy requirements have also increased in the last 6 years since the most recent shut down of a paper mill. However, due to the decrease in industrial customer energy requirements, the total island energy requirements have not surpassed the level set in 2004.

**Figure 5: Total Island System Energy Requirements (GWh)**

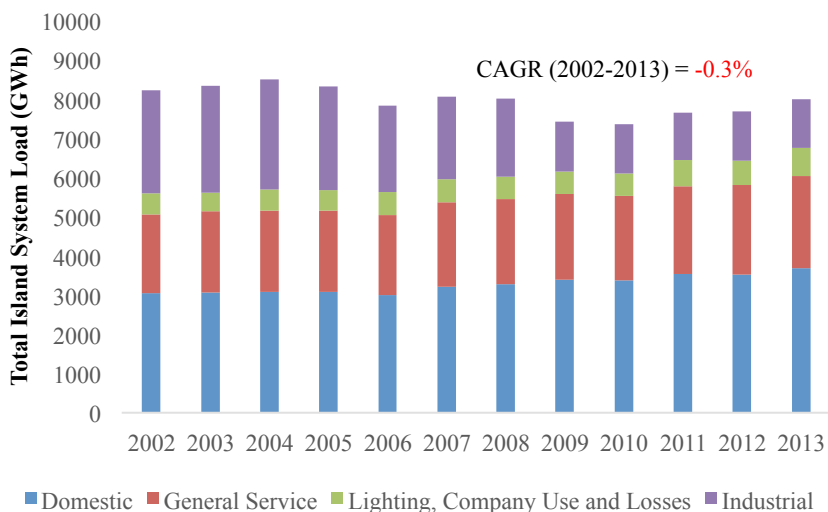

Source: NLH

Note: CAGR is compound annual growth rate.

The total IIS system peak has increased significantly over the last 5 years. As discussed, this reflects growth in residential and commercial customer requirements as well as increased industrial load given economic recovery.

**Figure 6: Total Island Interconnected System Peak (MW)**

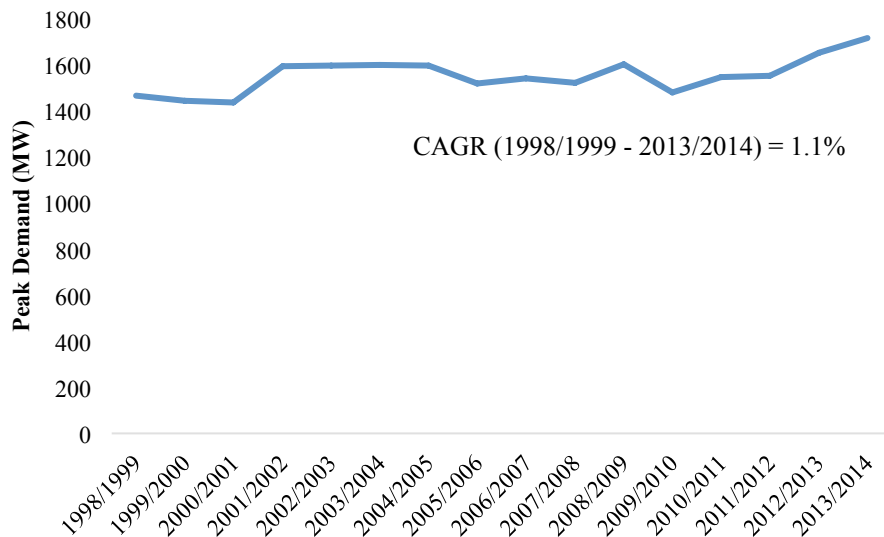

Source: NLH

### 2.2.1.2 *Island Interconnected System Transmission*

The IIS has a 230 kV backbone transmission system, which consists of 1,609 km of 230 kV transmission centered on the 604 MW Bay d’Espoir Hydroelectric Generating Station (Bay d’Espoir). There are eleven 230 kV lines totaling 628 km in length connecting Bay d’Espoir to the major load centers and generation in the eastern portion of the province. There are thirteen 230 kV lines totaling 981 km in length connecting Bay d’Espoir to major load centers and generation in the central and western portions of the province. The Upper Salmon and Granite Canal Hydroelectric Generating Stations are radially connected to Bay d’Espoir through two 230 kV lines. Figure 7 presents the province’s generation and transmission infrastructure.

The 230 kV transmission system to the west of Bay d’Espoir is relatively lightly loaded with a typical peak load of about 450 MW. The Cat Arm and Hinds Lake Hydroelectric Generating Stations and purchases from Non-Utility Generators (NUGs) supply more than 50% of the load requirements, resulting in the load on the 230 kV lines in the order of 210 MW. The minimum load on the west 230 kV lines during a typical summer night can fall to 115 MW. NLH has developed an operating strategy to control over-voltages on the lightly loaded lines by running generators in synchronous condenser mode.

NLH owns sixteen 138 kV transmission lines totaling 1,231 km, fifteen 66/69 kV transmission lines totaling 634 km and 52 high voltage terminal stations on the IIS. NLH’s 138 kV transmission lines are integrated with NP’s 138 kV transmission lines. The 138 kV network is supplied from six of NLH’s 230/138 kV substations, as follows:

- Deer Lake



- Bottom Brook
- Stony Brook
- Sunnyside
- Holyrood
- Western Avalon

In addition, NLH operates a number of radial transmission systems, as described below:

- Great Northern Peninsula (66/69 kV and 138 kV);
- White Bay (69 kV);
- Seal Cove Road to Bottom Waters (138 kV);
- Boyd’s Cove to Farewell Head (66 kV);
- Doyles – Port aux Basques (66 kV and 138 kV);
- Bottom Brook to Grandy Brook (138 kV);
- Bay d’Espoir to Barachoix (69 kV); and
- Burin Peninsula (138 kV)

### **2.2.1.3 Changes to the IIS**

With the development of the Muskrat Falls project, the IIS will gain two interconnection points: with Labrador by the Labrador-Island Link and with Nova Scotia by the Maritime Link. With the development of these two transmission facilities the IIS will be connected with the greater North American grid. This will have major implications for system operations and Newfoundland and Labrador’s electricity sector. As discussed further below, Nalcor will have access to additional electricity markets and there will be surplus energy available from Muskrat Falls. Therefore, ensuring access to the US Northeast market will be increasingly important making compliance with US Federal Energy Regulatory Commission (FERC) open access transmission requirements an important consideration.

Furthermore, with the IIS directly connected to the rest of the North American grid through the Maritime Link, the applicability of North American Electric Reliability Corporation reliability standards needs to be considered as well as the appropriate reliability standards for the IIS.

A new 230 kV transmission line is being added between Bay d’Espoir and the Western Avalon terminal stations. This line is required to be in service when the Labrador Island Link enters service but would also have been required for reliable operation of the system even if Muskrat Falls and the Labrador Island Link were not developed. An associated project to the Maritime Link is the construction of a 230 kV line between the Granite Canal and Bottom Brook terminal stations. These changes are illustrated in Figure 8.

**Figure 7: NLH Provincial Generation and Transmission Grid**



Source: NLH

Note: Figure excludes the 123.5 MW GT recently installed at Holyrood.

**Figure 8: IIS Transmission Network after ML and LIL**

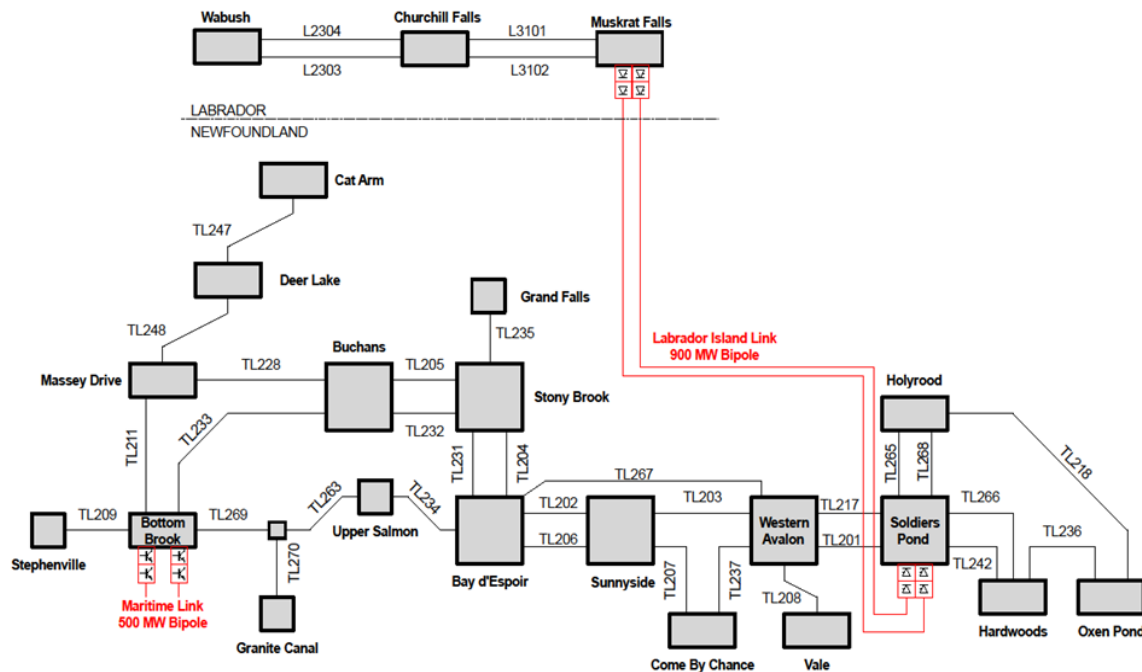

Source: NLH

Note: Figure excludes the 123.5 MW GT recently installed at Holyhood.

### 2.2.2 Labrador Interconnected System and Labrador West System

Customers connected to the Labrador Interconnected System (LIS) are supplied by NLH.<sup>17</sup> There are approximately 10,500 customers served on the LIS and hydroelectricity is the primary source of power generation.

The LIS has about 555 MW of hydroelectric, gas turbine and diesel capacity available to it. The vast majority of this capacity and energy is from the Churchill Falls generating station (i.e., the Recall Block and the former Twinco Block). The resources that comprise this capacity are identified below.

<sup>17</sup> Churchill Falls is referred to by some parties as Upper Churchill to distinguish it from the Muskrat Falls and Gull Island hydroelectric projects on the lower Churchill River. In this report, we refer to it as Churchill Falls.

**Table 2: Labrador Interconnected System Generation Resources**

<b>Resources</b>	<b>Capacity (MW)</b>
Happy Valley Goose Bay Diesels	5 <sup>18</sup>
Happy Valley Goose Bay Gas Turbines	25
Churchill Falls Recall Block	300
Churchill Falls former Twinco Block	225
Total	555

Source: NLH

---

<sup>18</sup> Derated due to fire.

**Figure 9: Labrador Electricity System Map**



Source: NLH

The Labrador electricity system depicted in Figure 9 consists of several 735 kV, 230 kV, and 138 kV lines that originate at Churchill Falls. There are three 735 kV transmission lines used for export, which are owned by CFLCo to transmit power and energy between Churchill Falls and the Hydro-Québec TransEnergie transmission network at Montagnais in northern Québec. In addition, there are two 230 kV transmission lines that transmit power and energy from Churchill Falls to various iron ore mines and other customers in Labrador City and Wabush in Labrador West. Finally, the LIS includes one 138 kV transmission line that transmits power and energy from Churchill Falls to Happy Valley – Goose Bay in eastern Labrador.

The “Labrador West Transmission Project” is a major new project for the LIS, which would add a new 230 kV transmission system between Churchill Falls and Labrador West. This project would

represent a significant change in the LIS. This transmission line is currently on hold until the Kami mine being developed by Alderon secures financing.

Figure 10 shows the daily load curves for the peak and low load days. The system experienced dual peaks on the peak day of approximately 440 MW although they are not much higher than the minimum load requirement on that day. One peak occurred in the morning and the other in the evening. The daily load variation was approximately 60 MW. The relative flatness of this load curve reflects the significant contribution of industrial demand, which is relatively constant.

The load demand on the low load day was quite flat, with only slight hourly variations. On that day load was in the 80 MW range.

**Figure 10: LIS Hourly Load Curves: Peak and Low Load Day**

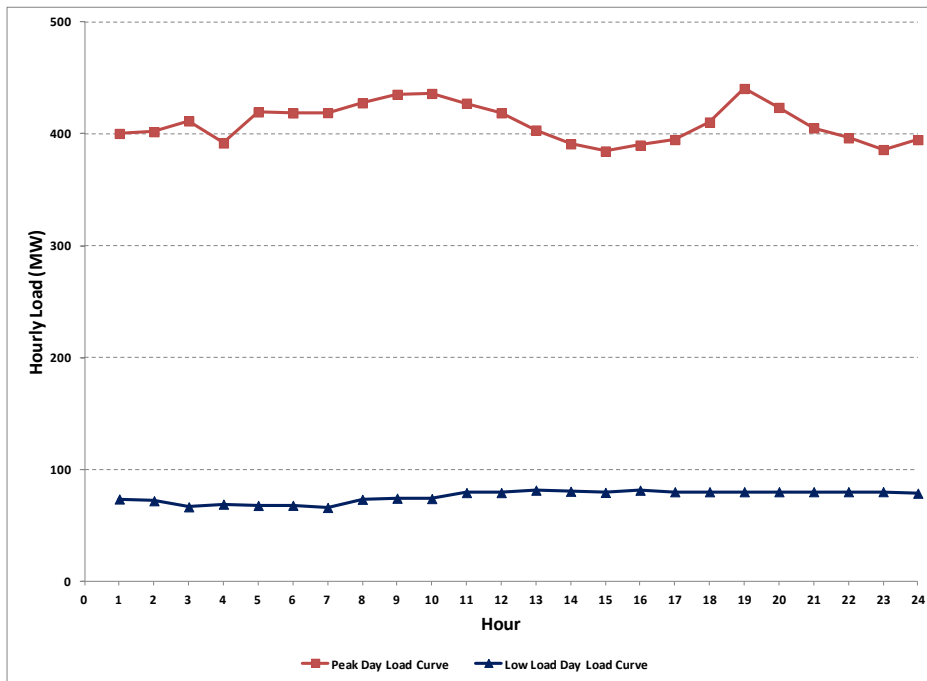

Source: NLH

Figure 11 presents the LIS monthly peak and energy demands in 2014. One could see from this figure that the annual peak occurred in February and the system had the lowest demand in two summer months, July and August. The energy demand in January was highest and in June was the lowest.

**Figure 11: LIS Monthly Load and Energy Requirements**

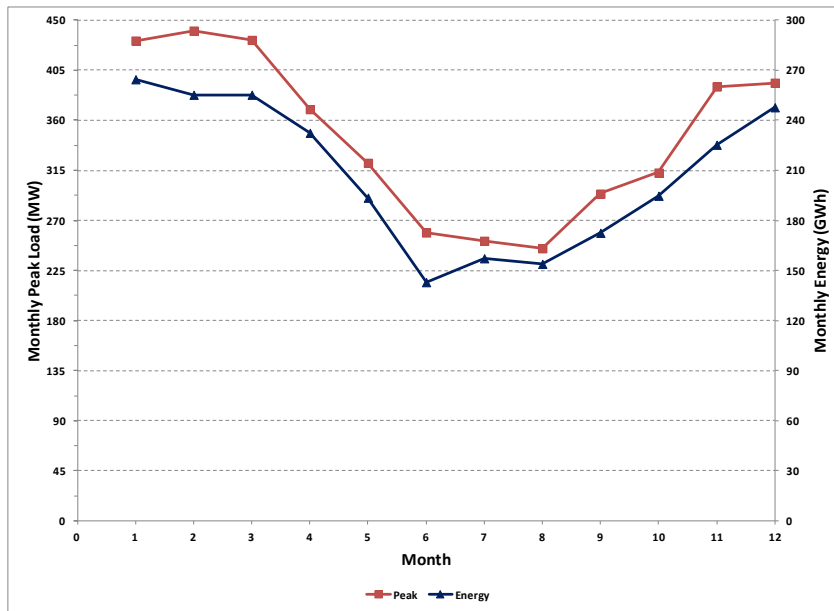

Source: NLH

Figure 12 presents the LIS hourly load duration curve in 2014. The annual peak was approximately 440 MW and there was only about 3% of the time during the year when the load level exceeded 400 MW. The lowest load in the year was only about 60 MW, i.e. less than 15% of the annual peak. There was about 8% of the year with a load level less than 200 MW.

**Figure 12: LIS Annual Load Duration Curve**

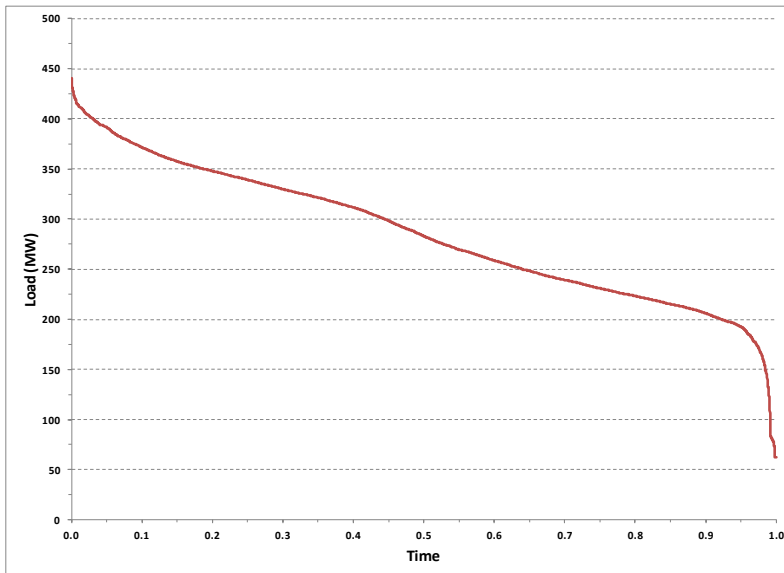

Source: NLH

As shown below in Figure 13, the annual energy requirement of the Labrador system has varied considerably since 2007, but forecast to recover. With electricity consumption in Labrador primarily attributed to industrial customers it varies based on their requirements and is more difficult to forecast.

**Figure 13: Labrador Annual Energy Requirements (GWh)**

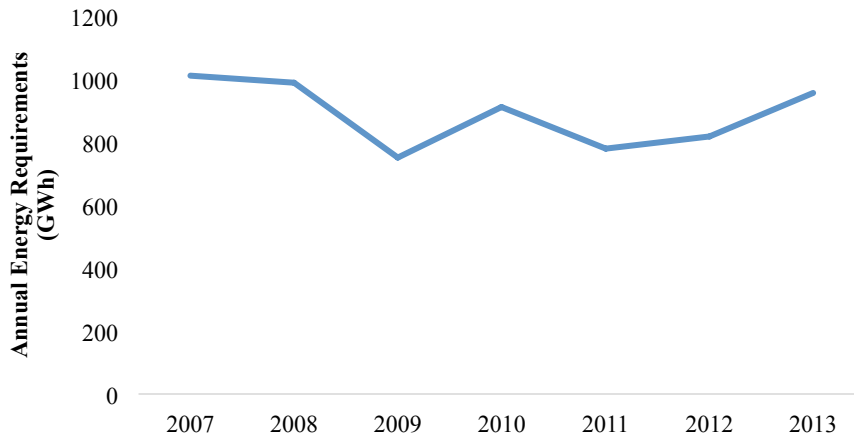

Source: NLH

### 2.2.3 Isolated Systems

Customers on 21 isolated systems on the coasts of Newfoundland and Labrador typically receive their power from diesel generators operated by NLH. Six of the isolated systems are on the Island and fifteen are in Labrador. The total installed capability of NLH's 21 isolated diesel peaking plants is 35.8 MW. The total isolated diesel system annual energy requirements have increased since 2007 at an annual rate of 3.4%, about twice the rate of IIS residential and commercial customers.



**Figure 14: Isolated Diesel System Annual Energy Requirements (GWh)**

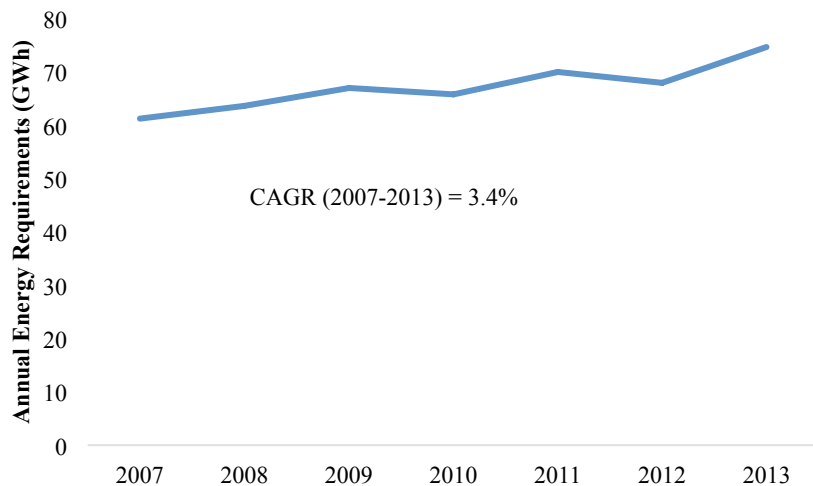

Source: NLH

Twelve of these isolated systems are accessible by boat or aircraft only, while the others can be accessed by the public highway system. The location of each of these systems is identified in Figure 15 below.

The isolated diesel customers in the Labrador Straits are also connected to Hydro-Québec’s Lac Robertson hydroelectric generating station which provides power when surplus hydroelectric energy is available. A brief description of the Island Isolated, Labrador Isolated, and Labrador Straights systems are provided below.

### **2.2.3.1 *Island Isolated***

On the Island portion of the province, approximately 800 customers in six communities are served by diesel generating plants with firm capacities ranging from 236 to 1,850 kW. Included in this area is the Ramea isolated system, which is served by a diesel/wind/hydrogen generation facility. This is a research and development project that uses renewable energy to displace the diesel requirements of this electrically isolated island community.

### **2.2.3.2 *Labrador Isolated***

In Labrador, including the Straits as discussed below, approximately 2,600 customers live in 27 rural isolated communities served by 15 diesel generation plants with firm capacities ranging from 90 to 6,050 kW. The locations of these diesel generators are indicated in Figure 15 below. In addition to the diesel generators, the Menihék Hydroelectric Generating Station provides surplus seasonal energy to the Labrador Iron Mines, and provides power to Hydro-Québec customers in the Schefferville region. Nalcor assumed ownership of this 18.7 MW generating station from the Iron Ore Company of Canada in 2007 and has entered into a 40-year power purchase agreement with

Hydro-Québec to supply electricity from this facility to its customers. The power generated from the Menihek Generating Station is the only source of electricity for this isolated area.

### 2.2.3.3 Labrador Straits

Customers in the L'Anse au Loup system area are connected to the Hydro-Québec Lac Robertson system and NLH purchases power from this hydroelectric plant. There is also a full diesel system operated by NLH. There are approximately 1,000 customers on this system.

**Figure 15: Newfoundland and Labrador Hydro Isolated Diesel System Map**



Source: NLH

## **2.3 Electricity Supply and Distribution Service**

A detailed description of the utilities, their affiliates and other entities that provide electricity in Newfoundland and Labrador is provided below.

### **2.3.1 Nalcor Energy**

The Energy Plan outlined that the Energy Corporation of Newfoundland and Labrador, later branded as Nalcor Energy (Nalcor), would play “a lead role in the province’s participation in the development of our energy resources...will be wholly owned by the province and will be the parent company of Newfoundland and Labrador Hydro (NLH), Churchill Falls Labrador Corporation (CFLCo), other subsidiaries currently owned by NLH and new entities created to manage the province’s investments in the energy sector.”

Nalcor is a provincial Crown corporation which was created in 2007. Nalcor has six primary lines of business: NLH, Churchill Falls, Oil and Gas operating as Nalcor Energy – Oil and Gas Inc., Lower Churchill Project,<sup>19</sup> Bull Arm Fabrication operating as Nalcor Energy – Bull Arm Fabrication Inc.,<sup>20</sup> and Energy Marketing.<sup>21</sup> The President and Chief Executive Officer of Nalcor also serves in these roles for each of these businesses. Nalcor provides functional support to these lines of business in the areas of finance, strategic planning and business development, engineering, human resources, communications, legal and audit.

Nalcor’s largest business is the generation and transmission of electrical power. Revenues from the sale of electricity represented approximately 87% of its revenue in 2013, with revenues from oil operations representing about 10% of the total; the remaining 3% is from a variety of sources including leases.<sup>22</sup>

### **2.3.2 Newfoundland and Labrador Hydro**

NLH is the primary generator and transmitter of electricity in Newfoundland and Labrador. Its mandate is to “ensure a safe, reliable and least-cost electricity supply to meet current demand and future growth.” NLH’s regulated operations consist of sales to three primary groups: (1) NP, which has 255,000 customers on the Island and represented 82.4% of regulated revenue in 2013; (2) over 38,000 residential and commercial customers in rural Newfoundland and Labrador, which comprised 14.6% of regulated revenue in 2013; and (3) major industrial customers including those in the pulp and paper, mining, and refining industries, which represented 3.0% of regulated revenues. The proportion of revenues from industrial customers in 2015 is expected to increase with the new industrial rate policy in Labrador and load growth from the Vale facility in Long Harbour.

---

<sup>19</sup> The various Lower Churchill Project entities are discussed in greater detail in Section 2.3.4.

<sup>20</sup> Bull Arm Fabrication serves the offshore petroleum industry and provides industrial fabrication capabilities.

<sup>21</sup> Energy Marketing’s present revenue and earnings are primarily from the sale of recall energy from Churchill Falls. This business segment also includes the Menihek Generating Station, which supplies power to Hydro-Quebec and a mining operation in Labrador.

<sup>22</sup> Nalcor, 2013 Annual Report, p. 76.

NLH provides distribution and retail services to customers in Labrador and in areas of the island of Newfoundland not served by NP, delivering power to utility, industrial, residential and commercial customers in more than 200 communities in the province.

As primarily a generation and transmission company, NLH has primary responsibility for demand forecasting, supply and transmission planning, system adequacy assessment, and system operations for the entire province. For its distribution systems, NLH also has responsibility for distribution system planning and operations.

NLH is regulated by the PUB, with rates set through periodic general rate applications using a cost-of-service methodology, which provides NLH with an opportunity to recover all reasonable and prudent costs incurred in providing electricity service to its customers including operating costs and a return on invested capital.<sup>23</sup> As discussed below, a relatively significant element of NLH customers' rates on the LIS (and NP customers' rates on the Island) are the Rural Subsidy which is used to subsidize rates of higher cost remote systems on the Island and in Labrador. The Rural Subsidy adds considerable complexity to the ratemaking process and has a significant impact on virtually all of the province's non-industrial customers' rates.

NLH's predecessor was the Newfoundland Power Commission (Power Commission), which was established by the government in 1954 to extend electrification within the province to rural areas. For the first few years, the Power Commission primarily served the Province in an advisory capacity. Between 1958 and 1964 the Power Commission was responsible for providing electrical service to many new customers, building transmission lines, and installing diesel plants. In 1975 the Power Commission was incorporated as NLH. In 2007 NLH became a wholly-owned subsidiary of Nalcor Energy.

Based on voltage, NLH has grouped its power delivery assets into two broad categories, as follows:

- Transmission: Transmission lines with a nominal operating voltage of 66 kV or greater and Terminal stations which contain a bus having nominal voltage equal to or greater than 66 kV
- Distribution: Transmission lines with a nominal three phase operating voltage of 46 kV and below. Distribution substations which contain nominal bus voltage equal to or less than 46 kV

NLH owns and operates over 3,700 kilometres of transmission lines on the IIS. This includes the high voltage (230 kV) transmission circuits which connect the system's largest generators, including those at Bay d'Espoir and Holyrood. In addition, NLH owns lower voltage (138 kV and 66 kV) transmission circuits which connect some of the more geographically remote distribution territories, including those on the Burin and Northern Peninsulas and the southwest portion of the IIS.

---

<sup>23</sup> Under cost-of-service ratemaking electricity rates are based on the underlying cost of providing the service.

NLH owns and operates 3,300 kilometres of distribution lines. Customer service activities address the requirements of its residential and commercial customers in rural areas of the province, NP, as well as all the Island’s industrial customers. NLH has the exclusive right to supply, distribute and sell electricity to a retailer or an industrial customer on the Island.<sup>24</sup> This right to sell power to all industrial customers is unique to the province, as service obligations are typically based on a defined service territory rather than a customer class.

To meet demand, which is growing (including residential demand growth and Vale’s industrial operation) at a .8% compound annual growth rate, NLH operates nine hydroelectric generating stations, one oil-fired steam plant, four gas turbines and 25 diesel plants. Figure 16 presents NLH’s generating capacity by fuel type. A majority of NLH’s generation assets are hydroelectric, currently representing over 50% of its installed capacity. Once Muskrat Falls comes into service, a significant amount of its energy will be made available to NLH<sup>25</sup> and 98%<sup>26</sup> of the province’s energy will come from renewable sources. At 490 MW, Holyrood’s three units represent approximately 25% of the island’s generating capacity. Two of the three units are over 40 years old and the third is 35 years old, which is significant, given the planned operating life for many thermal units is 35 years. As a residual oil-fired station, it represents a large portion of the island’s greenhouse gas emissions. Greenhouse gas and sulphur dioxide emissions from the facility have been a source of environmental and health concerns. The supply mix excludes the installed capacity of Churchill Falls which is owned by CFLCo.

**Figure 16: NLH Generation Capacity by Fuel Type (MW)**

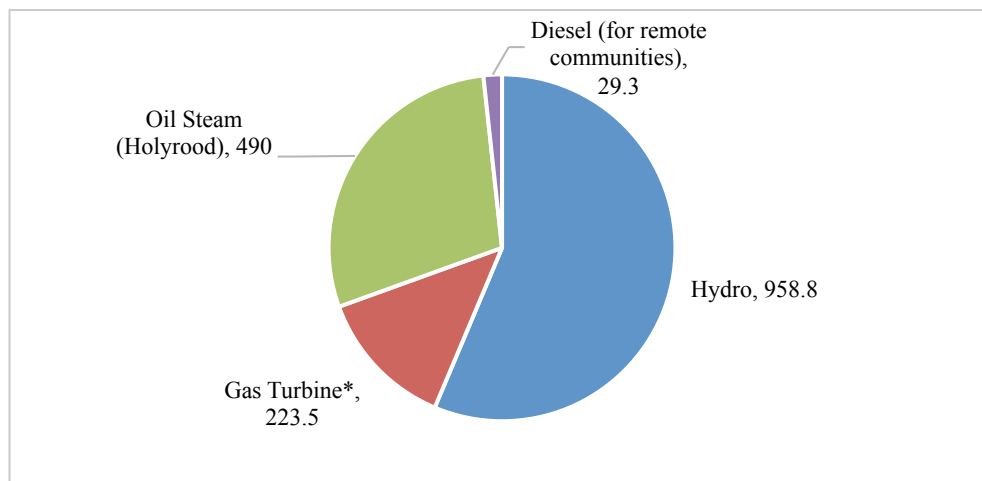

\* Includes 123.5 MW combustion turbine with first power in January 2015

Source: NLH

<sup>24</sup> Legislative amendments to the *Electrical Power Control Act, 1994* provided NLH the exclusive right to supply, distribute and sell electrical power or energy to a retailer or an industrial customer on the island portion of the province. See <http://www.assembly.nl.ca/business/bills/Bill1261.htm>. See further discussion in Section 3.1.1

<sup>25</sup> Muskrat Falls will be owned by the Muskrat Falls Corporation, not NLH.

<sup>26</sup> See <http://www.powerinourhands.ca/environment.asp>.

The figure below presents the ages of NLH’s generating assets by percent of generating capacity. Most of NLH’s generating assets are over 40-years old including the Holyrood generation station (two units over 40-years old) and the Bay d’Espoir hydroelectric generating station with six of the seven units over 40-years old. With periodic refurbishment of generator components (e.g., bearings and runners) the useful life of hydroelectric units can exceed 100 years.

**Figure 17: NLH Age of Generating Assets**

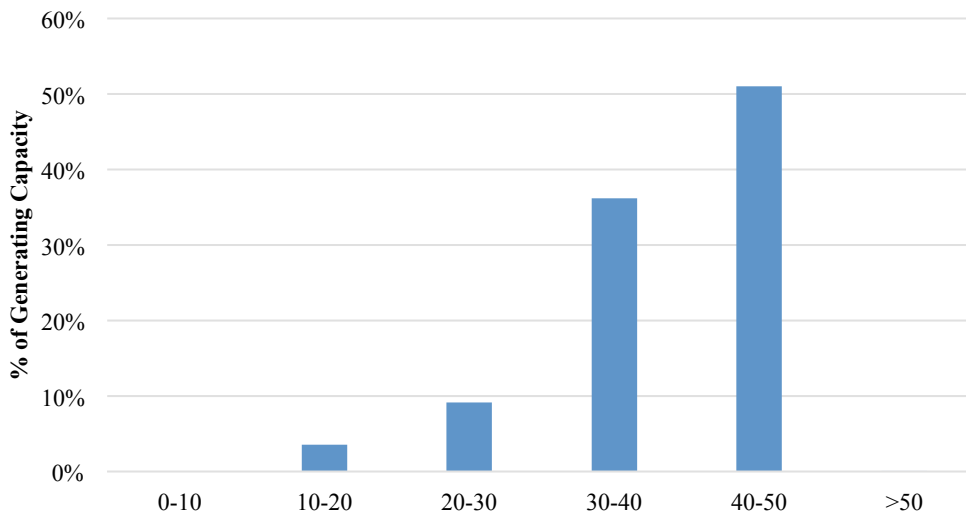

Source: NLH

NLH’s generation and transmission grid can be seen in Figure 7. NLH’s transmission system provides the transmission backbone for the island of Newfoundland with 230kV circuits running from Cat Arm in the northwest to the Avalon Peninsula in the southwest. Many parts of the NLH transmission system are supplied by radial circuits due to the low customer density and the geography of the Island.

### 2.3.3 Churchill Falls

The 5,428 MW Churchill Falls hydroelectric project is owned and operated by CFLCo, a single purpose entity, which in turn is jointly owned by NLH (65.8%) and Hydro-Québec (34.2%).<sup>27</sup> CFLCo has two consecutive power sale agreements with Hydro-Québec for the majority of the energy output of Churchill Falls with a total term of sixty-five years. In 1998, CFLCo signed a Guaranteed Winter Availability Contract with Hydro-Québec that guarantees the availability of firm capacity from the project during the winter period. A 2012 report by the Government of Newfoundland and Labrador noted that Churchill Falls produces significant wealth with the vast majority of value presently flowing to Québec:

<sup>27</sup> CFLCo also owns and operates three 735 kV transmission lines that transmit power and energy between Churchill Falls and Montagnais in northern Québec.

*“To illustrate how low the contract price is, in its 2010 annual report, HQ reported receiving \$1.034 billion for 12.6 Terrawatt hours (TWh) of electricity exports in that year - approximately \$82 per megawatt hour (MWh). By contrast, HQ currently pays only \$2.50 per MWh for Upper Churchill power and in 2010 NLH received just \$76 million in energy sales from its entire Upper Churchill business segment.”<sup>28</sup>*

The initial 1969 CFLCo contract with Hydro-Québec expires in 2016, with a twenty-five year renewal contract, expiring in 2041. The energy rate specified in the contract decreases from 0.25426 cents per kilowatt hour in 2013 to 0.20 cents per kilowatt hour when the second contract term begins in 2016.<sup>29</sup>

Following the 1961 sublease between CFLCo and Twinco, about 225 MW was provided to iron mines (IOC and Wabush Mines) in Labrador West, which replaced the capacity and energy that was provided by the Twinco hydroelectric facility, so that the water resource used by this facility could be used more efficiently in Churchill Falls.<sup>30,31</sup> The Twinco sublease expired at the end of 2014.<sup>32</sup>

In addition, as provided for in the CFLCo-Hydro-Québec contract, 300 MW at a 90% capacity factor is provided to NLH under the Recall Block. This energy is then sold by NLH to retail and industrial customers in Labrador and in various export markets in Eastern Canada and the US. To facilitate these export sales, NLH contracted for transmission capacity on the Hydro-Québec TransEnergie system under its Open Access Transmission Tariff (OATT). The agreement provides for long-term transmission of 265 MW of power through Québec to the New York border with the ability to transmit electricity to other markets. In 2013, NLH renewed this agreement for another ten years and under the OATT has a revolving renewal right.

In 2012, the government announced a Labrador industrial rate policy that provides for a single published electricity rate for all industrial customers on the LIS, coinciding with the conclusion of the Twinco sublease with CFLCo and consistent with the CFLCo Shareholders Agreement. The rate has generation and transmission components. The generation rate is posted by NLH and recalculated annually based on the formula outlined below, which allows NLH to realize market rates for a portion of these electricity sales as well as keeping the rate competitive with neighbouring provinces. The formula calculates a weighted average price from two blocks of power: a Development Block and a Market Block.

---

<sup>28</sup> Upper Churchill: Can we wait until 2041?, <http://www.powerinourhands.ca/pdf/UpperChurchill.pdf>

<sup>29</sup> 2013 Nalcor Energy Business and Financial Report, <http://www.nalcorenergy.com/uploads/file/Nalcor%202013%20Annual%20Report%281%29.pdf>

<sup>30</sup> <http://www.powerinourhands.ca/pdf/UpperChurchill.pdf>

<sup>31</sup> <http://www.pub.nf.ca/applications/Nalcor2009Water/files/applic/Application-VolumeII-Revised.pdf>

<sup>32</sup> Twinco was created to develop and own a 225 MW hydroelectric project on the Unknown River, a tributary to the Churchill River, in Labrador. Twinco was established by British Newfoundland Development Corporation, the original developer of Churchill Falls, in partnership with Wabush Mines Limited and the Iron Ore Company of Canada, the two mining corporations then operating in Labrador West.

The Development Block, supplied from the former Twinco Block and a portion of the Recall Block (both from Churchill Falls), offers below market prices. The Development Block price was set at \$22.43/MWh for 2015, which is considerably below market prices in order to encourage economic development. Nonetheless, the Development Block rate is considerably higher than the rate that was previously realized from these Twinco sales and therefore will provide additional revenue to CFLCo. The Development Block is available to all industrial consumers (existing and future) and fixed at 239 MW, the recent average consumption level of the existing customers in Labrador.

The Market Block includes all remaining industrial power required beyond the Development Block and its price is linked to market prices. It will be supplied from the remaining Churchill Falls Recall Block and other generation sources in Labrador, including Muskrat Falls. The Market Block allows NLH to earn market value for these electricity sales. It was set at \$45.52/MWh for 2015.<sup>33</sup>

In addition to charges for generation, industrial customers pay an additional amount based on the costs of required transmission. Under the policy, transmission service and rates became fully regulated by the PUB beginning in 2015 based on the cost of service, with rates recovering costs including a rate of return on the transmission assets in Labrador.

#### **2.3.4 Lower Churchill Project**

The first phase of the Lower Churchill Project includes various entities:<sup>34</sup> (1) the Muskrat Falls Corporation, which will own and operate the 824 MW Muskrat Falls Hydroelectric project; (2) the Labrador Transmission Corporation, which will own and operate the Labrador Transmission Assets which includes two 250 km, 315 kV HVac transmission lines between Muskrat Falls and Churchill Falls; and (3) the Labrador Island Link Limited Partnership (with Nalcor acting as the general partner and limited partnership holdings owned by both Nalcor and Emera), which will own the 1,100 km HVdc Labrador Island Link transmission facilities. Emera entered into various agreements with Nalcor to build the Maritime Link, which will connect Newfoundland and Labrador with Nova Scotia and provides a transmission path to the greater North American electricity market.

The second phase of the Lower Churchill Project involves the development of the 2,250 MW Gull Island (Gull Island) hydroelectric project. Development of Gull Island is contingent upon securing markets for this power. This project is discussed further in Section 2.4.

#### **2.3.5 Newfoundland Power**

NP, as a Fortis Inc. investor-owned utility, provides electricity distribution service to most of the Island. As primarily a distribution and customer service organization, NP has primary responsibility

---

<sup>33</sup> The Labrador Industrial Tariff provides for the price to be based on the average peak and off-peak price for NYISO Zone A as reported on New York Mercantile Exchange less losses on the Hydro-Quebec transmission system and other charges.

<sup>34</sup> This section describes the various Lower Churchill Project entities. The commercial arrangements for the development of the project are reviewed in Section 2.4.



for distribution system planning and operations within its service territories. NP also forecasts its customers' future requirements in coordination with NLH. NP's service territory is shown in Figure 18.

**Figure 18: Newfoundland Power Service Territory**

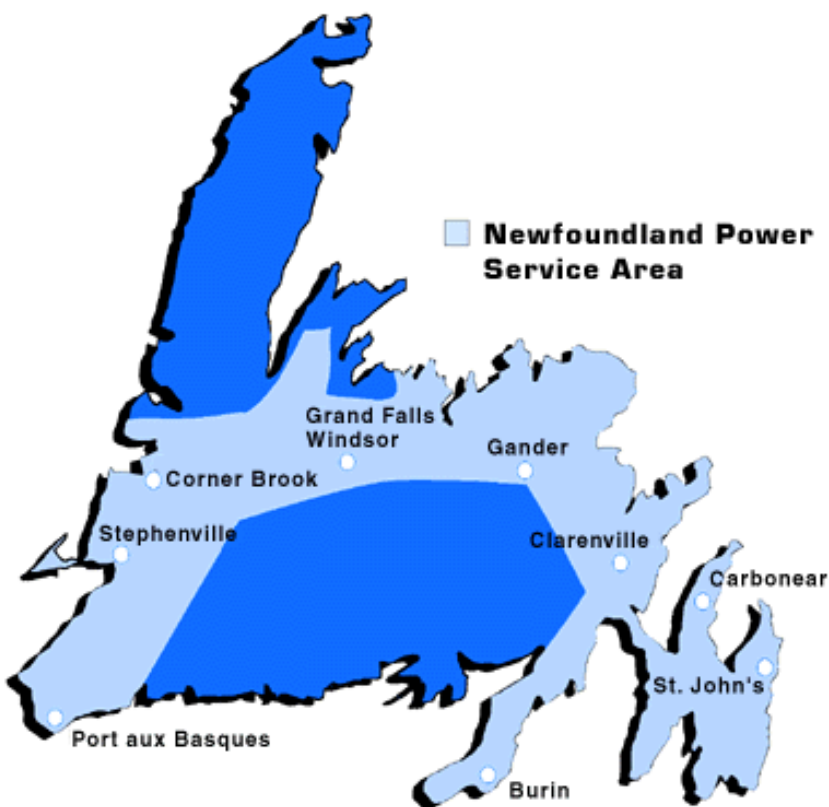

Source: NP

NP provides electrical service to three distinct categories of customers: domestic, general service and street and area lighting. The domestic service category refers to residential dwellings, and also includes non-residential services such as cottages, personal use garages and other metered services that qualify for the domestic rate category. In 2013, domestic customers accounted for 87% of NP's customers and 61% of its total energy sales. The general service category refers to commercial and institutional customers. In 2013, general service accounted for 9% of NP's customers and 38% of total energy sales. Street and area lighting represented 4% of NP's customers and 1% of total energy sales in 2013.

The following figure presents NP's system peak demand for the 2004-2013 timeframe. Reflecting growth in residential and commercial customer requirements, over this nine year period the peak

demand for NP has grown from 1,167 MW to over 1,300 MW with a compound annual growth rate (CAGR) of 1.5%. Since 2010/2011, NP’s peak demand has increased at a CAGR of 4.6%. An important driver of this growth is the residential sector where approximately 85% of the new homes have electric heat, which is a major contributor to peak load.<sup>35</sup>

**Figure 19: Newfoundland Power System Peak Demand (MW)**

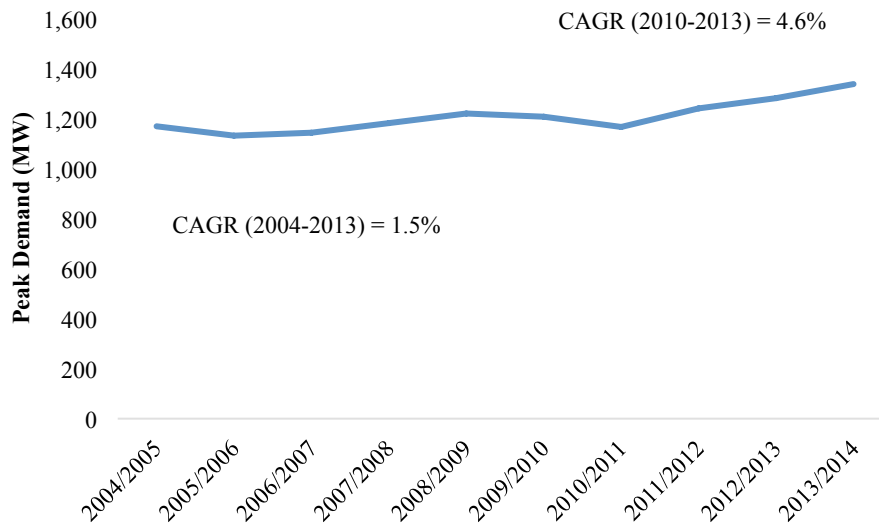

Source: NP

NP’s annual energy requirements from 2003 to 2013 are shown in the following figure. Annual energy sales for NP have increased at an annual rate of 1.7% since 2003 reaching over 5,700 GWh in 2013.

**Figure 20: NP Annual Energy Sales (GWh)**

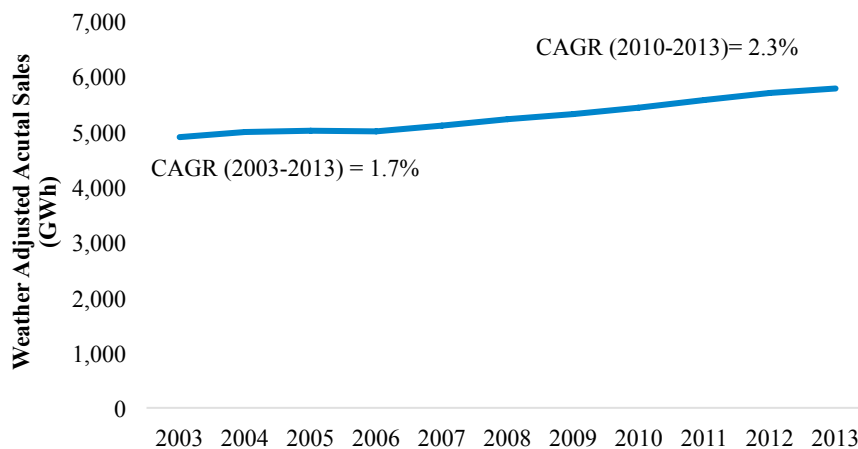

Source: NP

<sup>35</sup> Department of Natural Resources, p. 4.

NP-owned generation provides 137.7 MW of capacity, comprising approximately 6% of the total generating capacity of the IIS.<sup>36</sup> Approximately 70% of NP's generation is hydroelectric, representing 96.2 MW. The remaining 41.5 MW are fossil units, with 5 MW of diesels and 36.5 MW of gas turbines. The following figure presents NP's generating capacity by fuel type.

**Figure 21: Newfoundland Power Generation Capacity by Fuel Type (MW)**

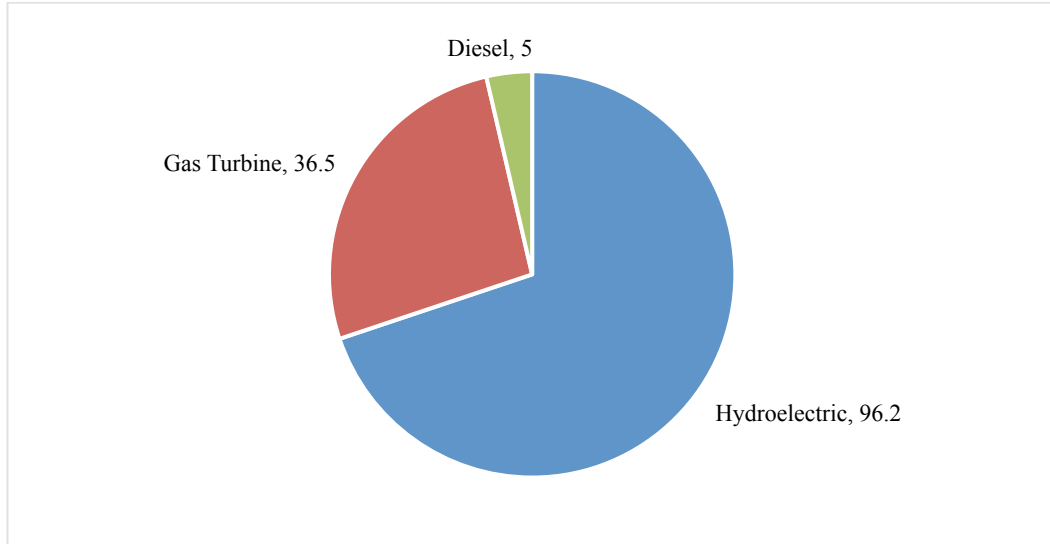

Source: NLH

Most of NP's generating units were constructed prior to the development of Bay d'Espoir and the subsequent creation of the IIS. They provided generation to isolated Island electricity systems which existed prior to the 1970s.

Figures 22 and 23 below present the ages of NP's generating assets by type of units and generating capacity, respectively.

---

<sup>36</sup> NLH Presentation to Power Advisory LLC, September 18, 2014.

**Figure 22: Newfoundland Power Age of Generating Assets by Type of Units**

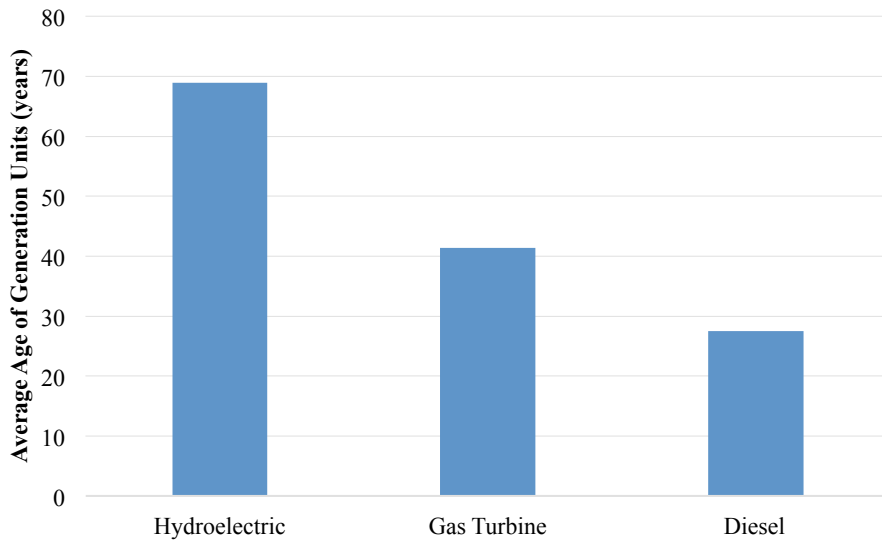

Source: NP

**Figure 23: Newfoundland Power Age of Generating Assets by Capacity**

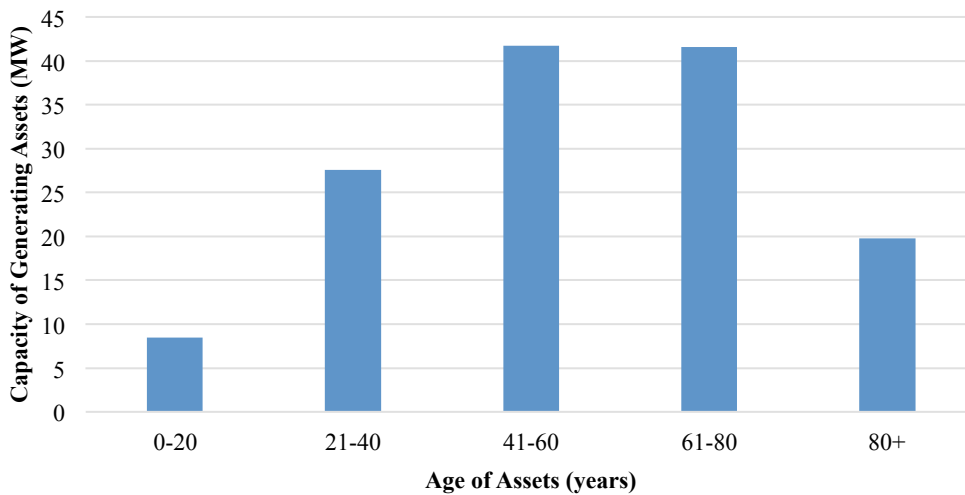

Source: NP

NP owns and operates, in coordination with NLH, approximately 2,100 km of transmission lines on the IIS. These all operate at lower transmission voltages (138 kV and 66 kV). NP transmission assets are primarily located in southeastern Newfoundland and concentrated on the Avalon Peninsula. Some were originally constructed by predecessor utilities or acquired in the 1960s as

part of the Provincial Rural Electrification Program.<sup>37</sup> Similar to its generation assets, the majority of NP’s transmission assets are over 30-years old, see Figure 24 below.

**Figure 24: Newfoundland Power Transmission Assets by Vintage**

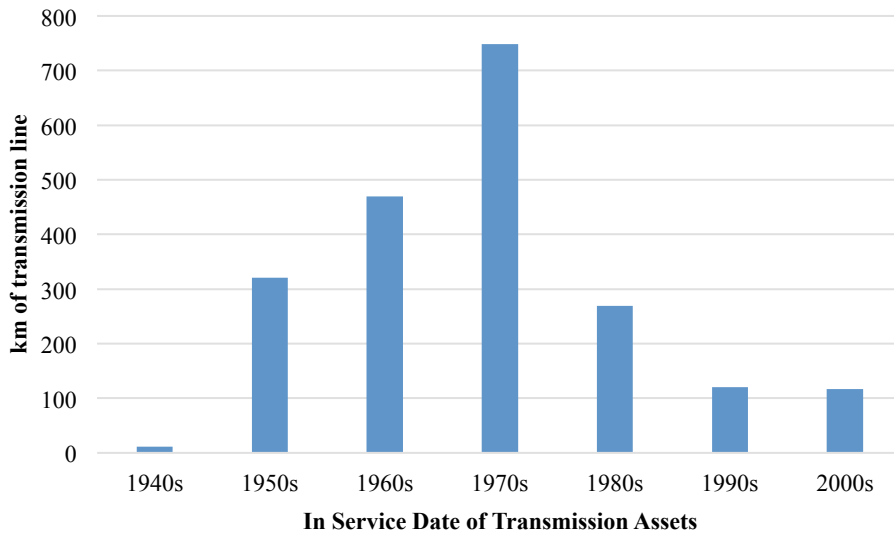

Source: NP

### 2.3.6 Non-Utility and Industrial Generators

Several industrial and non-utility generators operate in the province. These generators are described briefly below.

#### 2.3.6.1 Deer Lake Hydroelectric Generating Station

Deer Lake Power is owned and operated by Corner Brook Pulp and Paper Limited (Kruger Inc.) and has nine generating units with a total installed capacity of about 126 MW. Seven of these units operate at 60 Hz providing 81 MW while the other two operate at 50 Hz and provide 45 MW. However, only 18 MW from these 50 Hz units can be offered to the IIS through an NLH owned frequency converter. The 9 MW Watson’s Brook Hydroelectric plant is also located in Corner Brook. Corner Brook Pulp and Paper has an interim supply agreement with NLH that under normal conditions provides incentive for operating the generating units to most efficiently convert available water to energy. This agreement effectively reduces the amount of energy required from Holyrood and produces savings to customers.

#### 2.3.6.2 Corner Brook Biomass Project

The Corner Brook Pulp and Paper Mill also hosts a 15 MW biomass cogeneration project, which has a 20-year power purchase agreement with NLH and makes steam available to the mill.<sup>38</sup>

<sup>37</sup> How Things Run @ Newfoundland Power, Third Edition.

### **2.3.6.3 Fermeuse Wind Farm**

The Fermeuse wind farm is a 27 MW wind project located in Fermeuse on the Avalon Peninsula, with a 20-year PPA with NLH. The project consists of nine Vestas V90, 3 MW turbines and began supplying energy in April 2009. The project is owned by Elemental Energy. When announcing this contract, NLH indicated that the Fermeuse and St. Lawrence wind projects would displace 300,000 barrels of oil from Holyrood per year and would save about \$7 million annually compared to burning oil.<sup>39</sup>

### **2.3.6.4 St. Lawrence Wind Farm**

The St. Lawrence wind farm is a 27 MW project located in St. Lawrence on the Burin Peninsula, with a 20-year PPA with NLH. This project also has nine Vestas V90, 3 MW turbines and began producing wind power in October 2008. The project is owned by Enel North America Inc.

### **2.3.6.5 Rattle Brook Small Hydro**

Rattle Brook Hydro is a 4 MW hydroelectric project owned by Algonquin Power which has a 25-year PPA (started in 1998) with NLH.

## **2.4 Development of Muskrat Falls**

In December 2012, the Province sanctioned the development of the Muskrat Falls Project. The project sanctioning was the culmination of a comprehensive review of the environmental impacts of the project, its economics relative to alternatives as well as the reliability of the project. This review demonstrated that the project represented the least cost long-term option to provide electricity supply to the Island, with Holyrood nearing the end of its useful life. Furthermore, it offered significant environmental benefits given the sulfur, nitrogen oxide and carbon emissions that would be avoided by retiring Holyrood.

The 824 MW Muskrat Falls hydroelectric project depicted in Figure 25 below includes major transmission investments to deliver its energy to the IIS and to allow surplus energy to be sold to Nova Scotia, New Brunswick and further south into the US Northeast. In particular, the Muskrat Falls generating facility will be connected to the Churchill Falls Generating Station by two 315 HVac transmission lines (the Labrador Transmission Assets). At Muskrat Falls there will be an HVdc converter station and associated DC transmission facilities which will terminate at the Soldiers Pond converter station in Newfoundland. This HVdc system will be rated at 900 MW and these facilities are known as the Labrador-Island Link. This will be a  $\pm 350$  kV 900 MW HVdc bi-pole link based on conventional Line Commutated Converter technology with converter stations capable of operating in mono-polar mode. Each pole will be rated at 450 MW with 100% overload

---

<sup>38</sup> This unit is also capable of burning heavy oil.

<sup>39</sup> NLH News Release, *Hydro signs power purchase agreement for Fermeuse wind project*, <https://www.nlh.nl.ca/HydroWeb/NLHydroWeb.nsf/DisplayArchivedNews/ADBAC64CEBF33100A325754D0058A4FA?OpenDocument>.

capacity for ten minutes and 50% overload capacity for continuous operation. The bi-pole configuration provides two separate current carrying lines. If there is a failure that causes one of the poles to be taken out of service, the second pole could carry the entire 900 MW for up to ten minutes and could carry 675 MW indefinitely (450 MW plus 50% of 450 MW = 450 +225 = 675 MW). The converter stations will be located near Muskrat Falls in Labrador and Soldiers Pond near St. John's.

The completion of the Labrador-Island Link will result in major changes to the Newfoundland electricity system, as follows:

- Addition of a new 230 kV substation at Soldiers Pond in the St. John's area;
- Integration of the new Soldiers Pond 230 kV terminal station into the existing 230 kV network. The existing 230 kV network will be modified to establish new 230 kV transmission connections from Soldiers Pond terminal station, as follows:
  - Two 230 kV transmission lines to Holyrood terminal station,
  - Two 230 kV transmission lines to Western Avalon terminal station;
  - Two 230 kV lines to Hardwoods terminal station;
  - One 230 kV line to Oxen Pond terminal station.

In addition, there will be a 155 km HVac 230 kV transmission line from Granite Canal to Bottom Brook, a DC converter station at Bottom Brook and a 265 km HVdc 500 MW transmission interconnection from Bottom Brook, Newfoundland to Cape Breton, Nova Scotia where another DC converter station will be located. This will be a  $\pm 200$  kV 500 MW HVdc bi-pole link based on Voltage Sourced Converter technology and will connect Bottom Brook terminal station in Newfoundland to the Woodbine 345 kV substation in Nova Scotia. These facilities are known as the Maritime Link. The Maritime Link will be owned and operated by Emera Inc., an electric utility holding company, which also owns Nova Scotia Power, Inc., for thirty-five years and will revert to Nalcor at the end of this period. In addition, Emera will also invest in the Labrador-Island Link such that the sum of this investment and the investment in the Maritime Link does not exceed 49 percent of the aggregate capital costs of the Labrador-Island Link, the Labrador Transmission Assets, and the Maritime Link. Nalcor will be responsible for the design, engineering, construction, operation and maintenance of the Labrador-Island Link.

With the development of the Maritime Link, Labrador-Island Link and the Labrador Transmission Assets, the Island of Newfoundland will be directly connected to the North American electricity grid for the first time. This will result in the eventual shut down of the Holyrood Thermal Generating Station as a producer of power and electrical energy.

**Figure 25: Muskrat Falls Development**

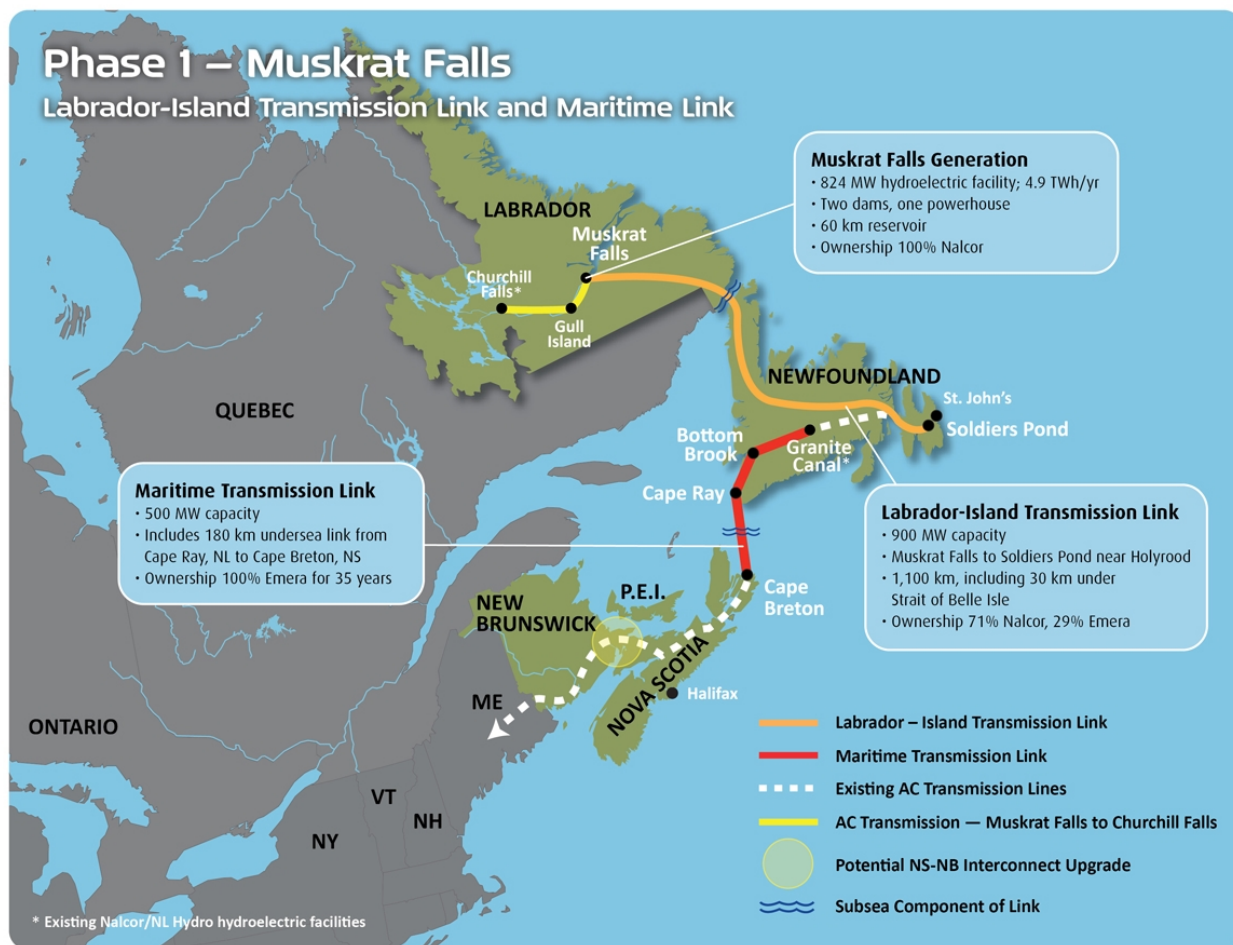

Source: Nalcor

### 2.4.1 Associated Power Sales Agreements

The PPA between NLH and Muskrat Falls Corporation provides for the purchase by NLH and the sale by Muskrat Falls Corporation of energy, capacity, ancillary services and greenhouse gas credits. Muskrat Falls Corporation will provide to NLH Base Block energy (Base Block) which is based on a forecast developed by NLH at the time of the execution of the PPA of its annual energy requirements from Muskrat Falls over a 50-year term. The Base Block Payments are based on the Project’s capital costs, which provides a return of and return on invested capital, and operations and maintenance costs. These Base Block payments are structured to recover the full costs of the project. For the purposes of capital cost recovery under the PPA, the Project consists of Muskrat



Falls and the Labrador Transmission Assets.<sup>40</sup> Under the PPA the monthly capital costs escalate over time which has the effect of reducing up-front rates.

In addition to the Base Block, Muskrat Falls will provide two additional blocks of energy to NLH: (1) Supplemental Block which is energy available to NLH if Island load requirements exceed the initial load forecast as reflected in the Base Block and is made available to NLH at \$1 per year; and (2) Commissioning Period Block which is energy available to NLH during the commissioning period at a price to be determined by NLH.

The PPA contains detailed provisions surrounding energy and capacity management/scheduling allowing the flexibility to export surplus power to export markets to the degree that Island native load requirements are met first. Muskrat Falls Corporation cannot sell excess energy to these export markets until NLH has an opportunity to nominate such energy to meet its load forecast in accordance with the stated scheduling provisions (e.g., NLH's 156 week forecast of energy requirements).

In addition, Nalcor executed various agreements with Emera for the construction of the Maritime Link and the provision of energy and capacity from Muskrat Falls. As noted above, in return for building the Maritime Link and providing transmission access through Nova Scotia, an Emera affiliate will receive 20% of the energy from Muskrat Falls, about a million MWh per year for 35 years (the "Nova Scotia Block"). The Maritime Link would be 100% owned by Emera for 35 years through a regulated utility, NSP Maritime Link Inc. The Nova Scotia Block will be available "on peak", between the hours of 7 am and 11 pm, seven days a week. Delivery quantities will be approximately 154 MW of firm capacity delivered to Nova Scotia (which corresponds to approximately 170 MW generated at Muskrat Falls). If transmission capacity is available, Nova Scotia Power can increase supply by up to 40 MW, to 194 MW, at any time during these hours, as long as the additional power is offset by a reduction to no less than 114 MW, resulting in exactly 2.46 GWh (154 MW x 16 hours) of supply every day. Schedule 5 to the Amended and Restated Energy and Capacity Agreement between Nalcor Energy and Emera (July 31, 2014) specifies the rights and scheduling procedures for shaping the profile, ramp rates, hours of delivery and other details.

The Nova Scotia Block also includes Supplemental Energy, which represents approximately 240,000 MWh per year for the first five years of the agreement as compensation for the fact that the useful life of the transmission facilities is at least 50 years whereas the Nova Scotia Block is only available for 35 years. This Supplemental Energy is available at a rate of 199 MW during off-peak hours (11 pm to 7 am only, seven days a week), during winter months only (November through March).

---

<sup>40</sup> The costs of the Labrador-Island Link are recovered under the Transmission Funding Agreement between the Labrador-Island Link Limited Partnership, Labrador-Island Link Operating Corporation and NLH.

In addition, Nalcor and Emera negotiated an Energy Access Agreement under which Nalcor commits to make available to Nova Scotia Power an additional 1.2 million MWh of non-firm energy per year on average over the course of the Agreement, which is expected to be from 2018 to 2041.

Beyond Muskrat Falls Corporation's sales obligations to NLH and Emera, additional energy will be available for resale in various export markets including Nova Scotia (for energy beyond the Nova Scotia Block), New Brunswick, PEI, Quebec and the US Northeast. With the growth in Newfoundland and Labrador electricity requirements, the amount of energy from Muskrat Falls available for sale in these export markets will decline.

#### **2.4.2 Implications of Project**

The development of the Muskrat Falls project and associated transmission facilities have significant implications for Newfoundland and Labrador's electricity system including the significant benefits of increased reliability and strategic export capabilities. With Newfoundland connected to the North American grid, it would be beneficial to reassess the appropriate reliability standard for the IIS including whether North American Electric Reliability Corporation reliability standards are appropriate for the province. These issues are considered further below.

A direct transmission connection, albeit through other provinces, to the competitive wholesale power markets in the US Northeast and surplus hydroelectric generation from Muskrat Falls and Churchill Falls also effectively ties the wholesale value of energy in Newfoundland and Labrador to these export markets.<sup>41</sup> With a direct transmission path to these markets, energy that is not consumed in Newfoundland and Labrador can be sold in these export markets. Under these conditions, the value of energy generated by hydroelectric plants in the province is based on prices in markets where Nalcor would be able to sell the power.<sup>42</sup> If policymakers are focused on maximizing economic efficiency this can have implications for how electricity should be priced in the province as well as conservation and demand management programs employed by NLH and NP to ensure efficient electricity consumption decisions by Newfoundland and Labrador consumers. These issues are considered further below.

With the development of the Maritime Link, Newfoundland and Labrador's transmission system will be a transmission path to other markets. Consideration will need to be given to the applicability of US Federal Energy Regulatory Commission open access transmission policies and to reciprocity provisions in interconnected Canadian utility transmission tariffs to ensure that various Nalcor affiliates are able to maintain access to export markets. These reciprocity provisions

---

<sup>41</sup> Effectively, the value of energy in Newfoundland and Labrador will be the "netback" of competitive wholesale prices in the US Northeast, which is the Northeast price less transmission losses and any transmission charges that would be incurred to deliver the power to that market.

<sup>42</sup> Under the *Public Utilities Act* and PUB precedent, electricity rates in the province will continue to be based on cost-of-service. However, with energy that is not consumed in the province potentially available for export it may make sense for Government to give consideration to the value of such exports in developing its electricity rates policy.

allow the transmission system operators to limit access to parties that are not viewed as providing an equivalent level of access to their transmission systems. This issue is discussed further in Sections 3.3.2.1 and 6.3.2.

## 2.5 Forecast of Future Energy Requirements

### 2.5.1 Island Interconnected System

A forecast of the energy requirements on the IIS from 2015 to 2032 is shown in Figure 26 below. NLH expects the annual energy requirements in the IIS to increase from 2015 to 2032 with a CAGR of 0.9%.

**Figure 26: Forecast Island Interconnected System Energy Requirements (GWh)**

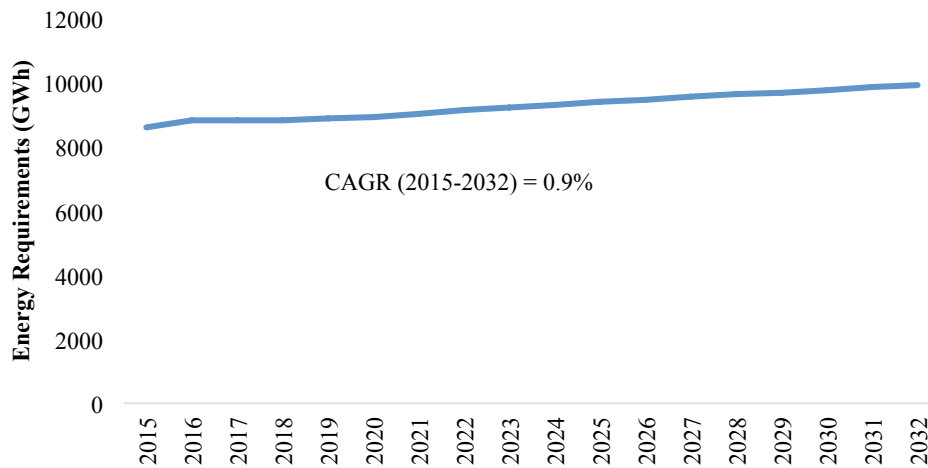

Source: NP and NLH

A forecast of the system peak, by utility, is presented below for the 2015-2032 timeframe. The system peak demand is forecasted to grow at a similar rate to annual energy requirements of 0.8% annually.

**Figure 27: Forecast Island Interconnected System Peak (MW)**

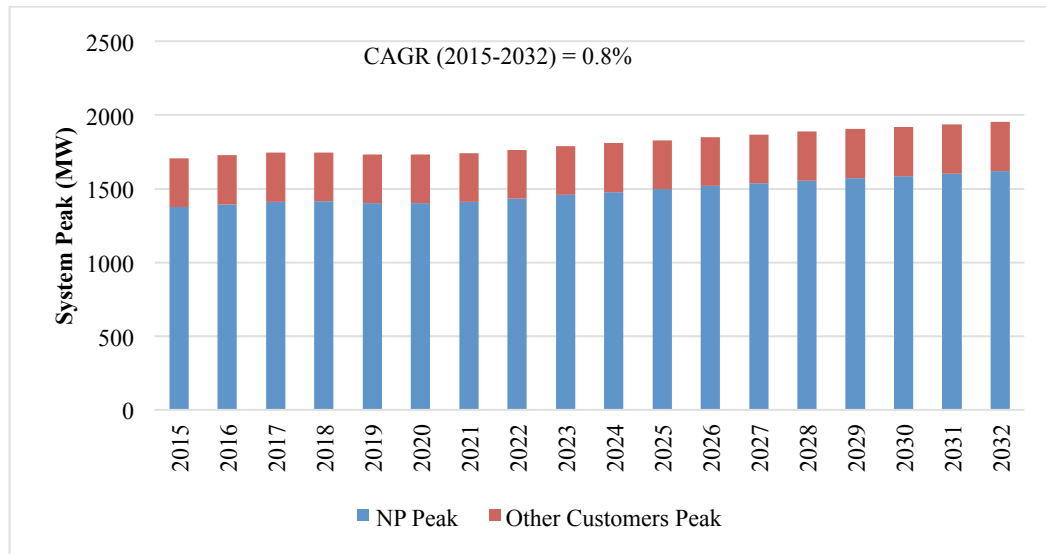

Source: NP and NLH

### 2.5.2 Labrador Interconnected System

At this time, the LIS is not resource constrained as available capacity and energy from Churchill Falls exceeds Labrador’s peak demand and energy requirements.

The system forecast to 2022 for peak demand and annual energy requirements for the LIS is presented in the following figure. The LIS annual energy requirement is expected to recover to historic levels. The LIS annual energy requirement decreased in 2009 by 25% from historical highs due to the global recession. NLH’s 2013 GRA indicated the company expected customer demand to return to the previous levels and to remain at that level to 2022.<sup>43</sup>

<sup>43</sup> NLH – 2013 General Rate Application – Section 1.1.3 Medium-Term Outlook. Page 1.10.

**Figure 28: Labrador Interconnected System Forecast**

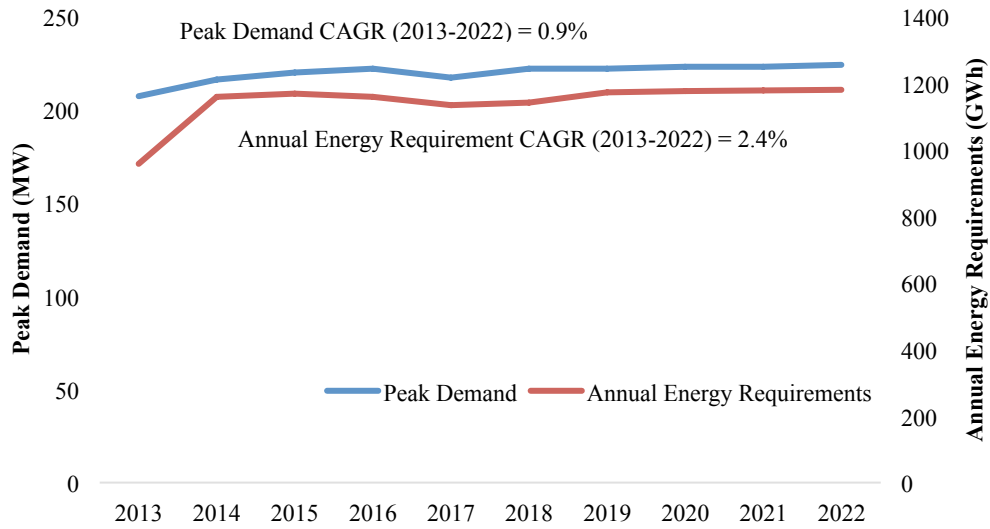

Source: NLH

### 2.5.3 Newfoundland and Labrador Combined Interconnected System

Nalcor expects to energize the Labrador-Island Link in 2017/18 which will for the first time connect the IIS with the LIS as depicted in Figure 29 below.

**Figure 29: Labrador-Island Transmission Link**



Source: Nalcor

The combined Newfoundland and Labrador interconnected system will allow NLH to consider pooled generation assets to meet future system needs for both the IIS and LIS, resulting in system efficiencies. The combined annual energy requirements and peak demand for IIS and LIS from 2017 to 2022 is shown in Figures 30 and 31 below. The peak demand for the IIS and LIS are not coincidental (i.e., at the same time). Therefore, the coincidental peak (i.e., the combined cumulative peak) is likely to be lower than the separate peaks which in the figure below are the simple sum of the IIS and LIS peaks.<sup>44</sup>

**Figure 30: Annual Energy Requirement for LIS and IIS**

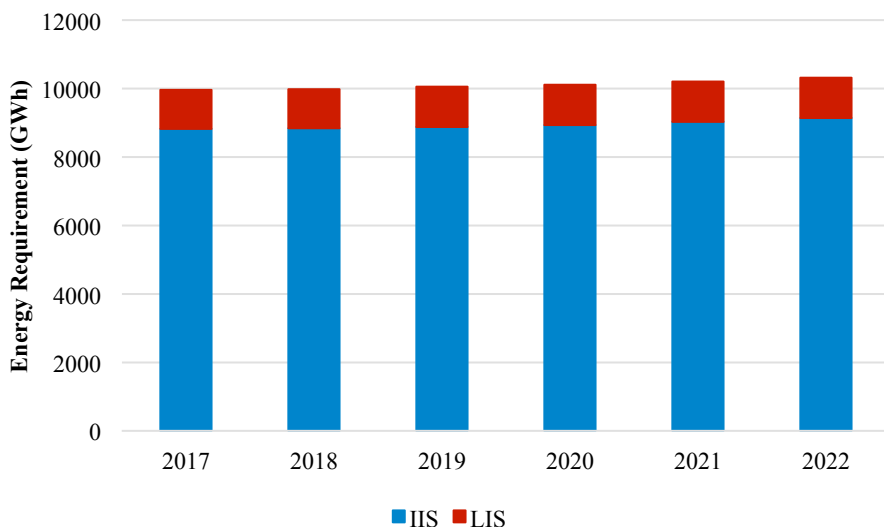

Source: NLH

<sup>44</sup> For example, if the IIS peak is typically at 6 PM on a cold winter weekday and driven by residential heating, lighting and cooking loads, whereas the LIS peak is driven by industrial requirements and therefore is typically from 9 to 11 AM as industrial demands ramp up, then the combined system peak will be less than the sum of the individual peaks of the two systems.

**Figure 31: Combined Peak Demand Forecast for IIS and LIS (MW)<sup>45</sup>**

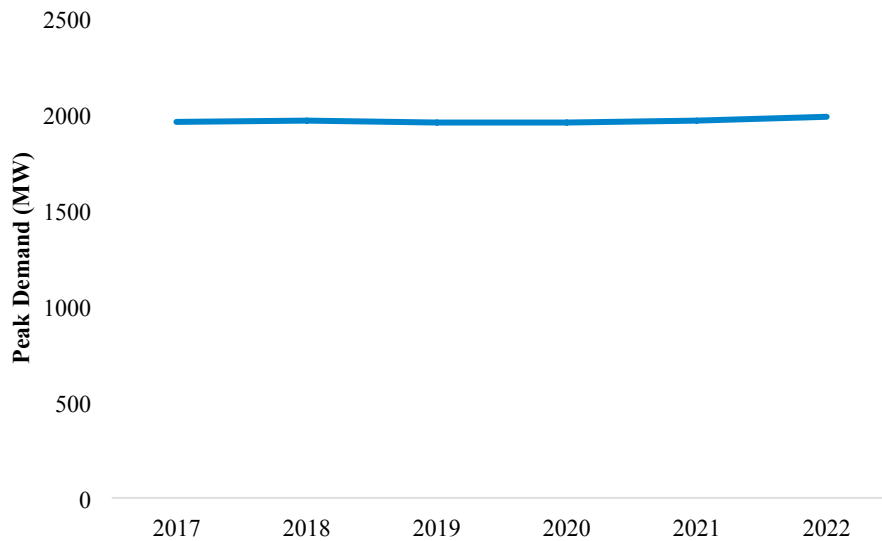

Source: NLH

## 2.6 Electricity Rates in Newfoundland and Labrador

There are five distinct electricity costs of service in Newfoundland and Labrador for the different systems which include the: (1) Island Interconnected System; (2) Island Isolated Systems; (3) Labrador Interconnected System; (4) Labrador Isolated Systems; and (5) L'Anse au Loup. For customers on the IIS there are rates for domestic service (residential), general service (based on four different ranges of demand levels), street and area lighting, and industrial customers.<sup>46</sup> Rates for NP and NLH customers on the IIS in the same rate class are the same.<sup>47</sup> On the Labrador Interconnected System and for the various isolated systems there are similar rate classes, but distinct rates that reflect differences in the costs of providing the service, particularly in the underlying cost of the generation resources. Domestic customers on the isolated systems receive an initial block of energy that is priced at the same level as that paid by other domestic customers on the relevant interconnected system (i.e., Island or Labrador) regardless of the underlying isolated system's cost of service. The differences in the cost and the revenue received in rates is funded by NP customers and Labrador interconnected retail customers who pay a premium to subsidize the cost of service for retail customers in more rural or remote systems through a mechanism called the Rural Subsidy. This subsidy provides domestic customers with a block of energy averaging 850 kWh per month (from 700 kWh in summer to 1,000 kWh in winter) at NP retail rates to cover basic needs, such as lighting, cooking and water heating, as well as the basic customer charge for residential customers. It also provides electricity at rates below cost for general service customers

<sup>45</sup> The peak demand hour for the IIS and LIS are unlikely to be coincident and therefore the peak demand of the combined system will likely be lower. Figure 31 is provided for illustration only.

<sup>46</sup> NP also has a curtailable service option for the two largest commercial service customer groups.

<sup>47</sup> Under NLH's Rate Manual, "as Newfoundland Power changes its rates, Hydro will automatically adjust all rates such that these customers pay the same rates as Newfoundland Power customers." (p. RR-14).

and for domestic customer consumption levels exceeding the basic needs block. The Rural Subsidy adds considerable complexity to the ratemaking process; has a significant impact on NP customers' bills and accordingly results in significant cross-subsidies among different customer groups. These issues are discussed further below.

Government's 2007 Northern Strategic Plan provides an additional subsidy to further reduce basic block rates for Labrador domestic diesel customers to the rates paid by Labrador interconnected domestic customers. L'Anse au Loup customers pay the same rate as IIS customers as a result of Northern Strategic Plan credit for the basic customer charge and the first block of energy. After the first energy block L'Anse au Loup customers pay a higher rate.

Table 3 compares average electricity prices in St. John's with those in eleven other Canadian cities. As indicated, electricity prices in St. John's typically are in the 2<sup>nd</sup> quartile (i.e., from 4<sup>th</sup> to 6<sup>th</sup> lowest). Rates in Montreal, Winnipeg and Vancouver, all of which are served by Crown-owned predominately hydroelectric utilities, are generally lower. Interestingly, average electricity prices in St. John's are the most competitive for the largest industrial customer category. For this rate category the average electricity price in St. John's is the second lowest and only 22% above the lowest rate whereas for the other rate classes average electricity prices range from about 40 to 80% higher than the lowest rate.

NP and NLH's rates have been subject to annual Rate Stabilization Plan (RSP) adjustments to account for differences between forecasts and actual results for hydraulic production, fuel oil costs at Holyrood, customer load and rural rates.<sup>48</sup>

---

<sup>48</sup> With the exception of those served from the Labrador Interconnected System.



**Table 3: Average Electricity Prices by Canadian Cities on April 1, 2014**

	Residential	Small Power	Medium Power			Large Power	
<b>Power Demand (kW)</b>		40	500	1,000	2,500	5,000	50,000
<b>Consumption (kWh)</b>	1,000	10,000	100,000	400,000	1,170,000	3,060,000	30,600,000
<b>Load Factor</b>		35%	28%	56%	65%	85%	85%
<b>Montreal</b>	7.06	9.5	11.7	7.66	6.5	5.05	4.78
<b>Calgary</b>	13.41	10.57	10.92	8.15	7.8	7.42	7.4
<b>PEI</b>	15.24	15.92	16.73	13.33	12.83	8.71	8.71
<b>Edmonton</b>	11.88	11.11	13.9	10.4	9.79	8.87	7.51
<b>Halifax</b>	16.03	15.38	17.09	12.83	11.17	9.86	9.86
<b>Moncton</b>	12.06	12.7	13.66	11.19	10.83	7.34	7
<b>Ottawa</b>	13.45	13.29	15.79	13.86	13.77	13.31	10.87
<b>Regina</b>	13.95	11.61	13.71	10.15	8.46	7.56	6.32
<b>St. John's</b>	11.34	11.39	11.9	9.32	8.81	8.42	4.77
<b>Toronto</b>	13.78	12.8	14.88	12.04	11.59	11.13	11.03
<b>Vancouver</b>	9.71	10.15	10.21	7.69	7.16	6.66	5.51
<b>Winnipeg</b>	7.89	7.34	8.56	5.96	5.03	4.54	3.91
<b>Analysis of Average Electricity Prices in St. John's versus other Canadian Cities</b>							
<b>Mean</b>	12.15	11.81	13.25	10.22	9.48	8.24	7.31
<b>Rank</b>	4	6	4	5	6	5	2
<b>% Above Lowest</b>	61%	55%	39%	56%	75%	85%	22%
<b>Relative to Mean</b>	-7%	-4%	-10%	-9%	-7%	2%	-35%
<b>Std Deviation</b>	265%	231%	254%	242%	254%	234%	230%

Source: Hydro-Québec, *Comparison of Electricity Prices in Major North American Cities*, 2014.

Available at:

[http://www.hydroquebec.com/publications/en/comparison\\_prices/pdf/comp\\_2014\\_en.pdf](http://www.hydroquebec.com/publications/en/comparison_prices/pdf/comp_2014_en.pdf)

### 2.6.1 Analysis of Rate Drivers

Provincial electricity rates are overseen by the PUB. The PUB employs cost-of-service regulation to establish electricity rates which reflect the cost of owning, operating and maintaining the generation, transmission, and distribution facilities required to serve different customer classes. Electricity rates are impacted by a number of factors including fuel costs, capital investments in the electricity system and overall cost of operations. In addition, the Rural Subsidy increases rates outside of rural areas so that the rates of customers in rural and remote areas can be lower. Government also provides subsidies (e.g., Northern Strategic Plan) to lower electricity costs.

Figure 32 indicates the various contributors to the costs of electricity service in Newfoundland and Labrador. This figure combines the cost of service for NLH and NP to estimate the total cost of electricity service for the province.<sup>49</sup> The power purchases reflect the costs paid by NLH for its various power purchase agreements.

**Figure 32: Costs of Electricity Service**

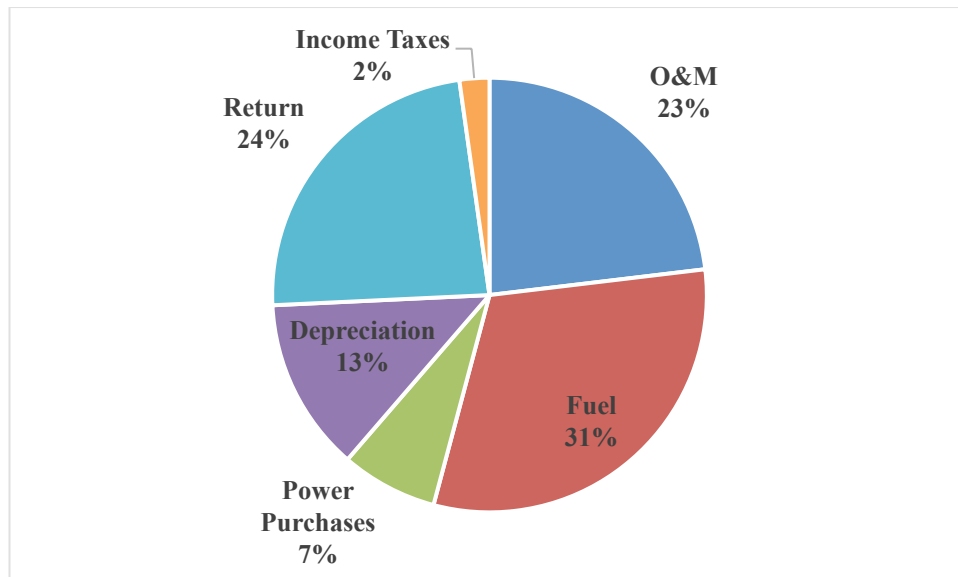

Source: Power Advisory Analysis of NLH and NP data

**2.6.1.1 Fuel Costs**

As shown in Figure 32 above, fuel costs represent a significant share of the total cost of service, with the vast majority of these costs represented by fuel oil for Holyrood. Clearly increases in fuel costs can drive rate increases. As the Holyrood Generating Plant, one of the largest generating stations on the island, is oil-fired, the cost of electricity produced by this station is susceptible to swings in oil prices. Increasing demand for electricity on the Island means greater production from Holyrood and a greater role in influencing electricity rates. Oil price increases have been a major contributor to rate increases for Island customers.<sup>50</sup> By comparison, customers on the Labrador Interconnected System benefit from lower electricity rates, which are attributed to hydroelectricity from Churchill Falls being the predominate source of power generation for that system.

<sup>49</sup> This is an approximation given no consideration is given to costs for other sources of power (e.g., 239 MW from CFLCo for the Development Block.) NP’s purchased power expense, which represents about 60% of its total cost of service, is not considered because it is based on purchases from NLH, the costs of which are already considered.

<sup>50</sup>NLH News Release: *Newfoundland and Labrador Hydro files for adjustment to electricity rates through the Rate Stabilization Plan*. Available here: [https://www.nlh.nl.ca/hydroweb/nlhydroweb.nsf/0/6D469EC5A96B0CF2A3257CCB0046671C/\\$File/News%20release\\_NL%20Hydro%202014%20RSP%20Rate%20change\\_Final.pdf](https://www.nlh.nl.ca/hydroweb/nlhydroweb.nsf/0/6D469EC5A96B0CF2A3257CCB0046671C/$File/News%20release_NL%20Hydro%202014%20RSP%20Rate%20change_Final.pdf).

### 2.6.1.2 Capital Investments

Not surprisingly given the capital intensiveness of the electricity sector, capital charges (return, depreciation and income taxes) represent almost 40% of the total cost of service. With much of the province's electricity infrastructure over 40 years old, significant investments in generation and transmission infrastructure are required to ensure reliability.<sup>51</sup> Reflecting in part this investment, capital spending for both NLH and NP has increased appreciably over the past five years with NLH's capital spending increasing over the past 5 years at a CAGR of 8.4% and NP's capital spending increasing at a 7.4% rate. The annual capital budgets between 2009 and 2013 for each utility are shown in the table and figure below. Additionally, Tables 4 and 5 and Figure 33 present capital expenditure forecasts for each utility over the 2014 to 2018 timeframe.

**Table 4: NLH and NP Capital Budgets**

Utility	Capital Budget <sup>52</sup> (\$000)				
	2009	2010	2011	2012	2013
NLH	47,856	52,775	65,058	87,862	66,144
NP	61,945	73,735	73,318	79,301	82,428

Source: NLH Five Year Capital Plans and NP Capital Expenditure Status Reports available on PUB website

**Table 5: NLH and NP Capital Budget Forecasts**

Utility	Capital Budget Forecast <sup>53</sup> (\$000)				
	2014	2015	2016	2017	2018
NLH	279,020	274,249	313,640	223,371	169,708
NP	84,462	89,765	95,325	93,975	91,943

Source: NLH Five Year Capital Plans and NP Capital Expenditure Status Reports available on PUB website

<sup>51</sup> See page 1 of NLH News Release: *Hydro investing \$55 million in the provincial electricity system in 2011*  
[https://www.nlh.nl.ca/HydroWeb/NLHydroWeb.nsf/DisplayArchivedNews/0E9B72E6AA9906E4A32578A90061C595/\\$File/NewsRelease2011CapitalProgram.pdf](https://www.nlh.nl.ca/HydroWeb/NLHydroWeb.nsf/DisplayArchivedNews/0E9B72E6AA9906E4A32578A90061C595/$File/NewsRelease2011CapitalProgram.pdf).

<sup>52</sup> Based on forecast.

<sup>53</sup> Based on forecast.

**Figure 33: NLH and NP 2009-2013 Capital Budgets and 2014-2018 Capital Expenditure Forecasts**

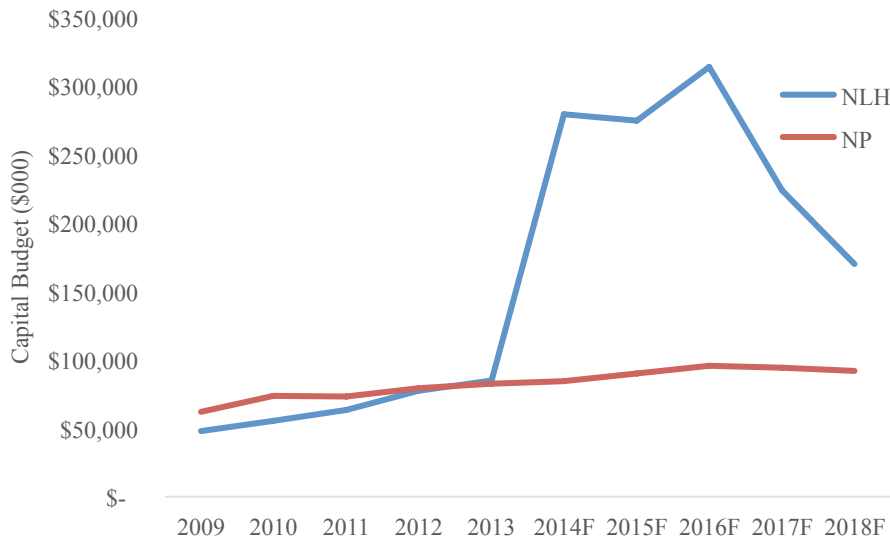

Source: NLH Five Year Capital Plans and NP Capital Expenditure Status Reports<sup>54</sup>

NLH’s capital plan over the 2014 to 2018 period anticipates average annual capital expenditures of \$252 million. The increase in overall capital expenditures reflects the requirement for specific projects to replace and upgrade deteriorating facilities, ensuring compliance with legislation, and most particularly additions required to meet load growth. The large increase over the 2014 to 2017 timeframe can be partially attributed to three large projects: the addition of a combustion turbine at Holyrood GS; the installation of 230 kV transmission lines from Bay d’Espoir to Western Avalon; and the Labrador West Transmission Line.<sup>55</sup> Even with these major projects removed, average annual capital expenditures for the period 2014 to 2018 is estimated to be \$103M which is almost 60% higher than the average during the 2009 to 2013 period. Figure 34 provides the capital expenditures forecast with these three projects shown separately. The projects are included in the capital expenditures forecast but have been filed or will be filed with the PUB separately for approval.<sup>56</sup>

<sup>54</sup> NP Capital Budget Application 2014 and NLH Capital Budget Application 2015.

<sup>55</sup> Construction work on the Labrador West transmission line has been paused, while financing for Alderon Ore’s mine is completed. The capital expenditure values in the figure have not been adjusted for this suspension given the uncertainty regarding the timing as to when construction may resume. Therefore, the figure clearly overstates 2015 capital expenditures and may understate near term future year expenditures.

<sup>56</sup> The Labrador West transmission project was exempted from the requirements of the *EPCA* and *PUA* by a government directive.

**Figure 34: NLH Capital Budget Forecast Separated by Major Projects**

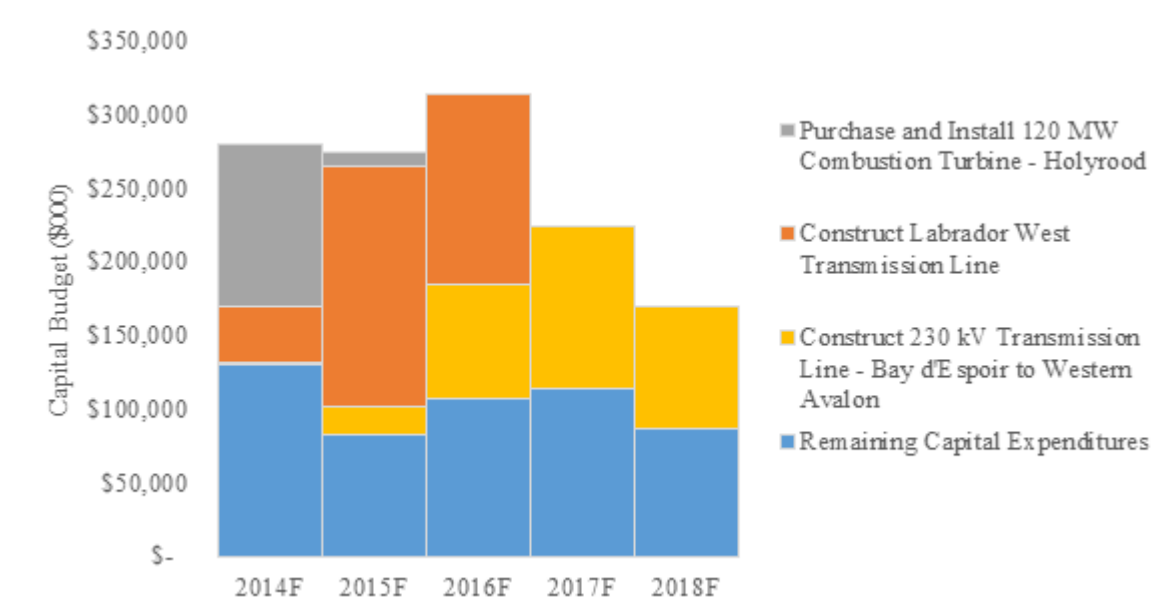

Source: NLH Five Year Capital Plans<sup>57</sup>

The Muskrat Falls project is an additional major capital investment that will also be recovered in electricity rates in the future. Given the magnitude of the investment, there will be rate increases associated with the project. In other North American jurisdictions where large capital projects have been added to the supply system and could have caused significant rate increases or “rate shock”, policy makers and regulators have mitigated the rate impacts through various measures such as spreading out the initial rate impacts over a longer period of time. Reducing significant rate increases for large long-term capital investments is a common practice.

### 2.6.1.3 Operating and Maintenance Costs

The operating and maintenance costs represent 23% of the total cost of service. These costs reflect salaries and wages and associated benefits for utility staff and various other operating expenses which include all non-fuel expenses and capital charges.

## 2.7 Summary

The Newfoundland and Labrador electricity sector generation supply mix is primarily composed of hydroelectric generation with supporting thermal units (diesel, gas turbine and oil steam). Many of the thermal generation assets owned by NLH and NP are old, with the larger units (e.g., Holyrood) requiring replacement or refurbishment in the near future.<sup>58</sup> The average age of all generation units is 45 years with a capacity weighted average age of 38 years.

<sup>57</sup> NP Capital Budget Application 2014 and NLH Capital Budget Application 2015.

<sup>58</sup> This and the units impending retirement are having an impact on NLH’s asset management strategy for Holyrood.

Annual energy requirements have not exceeded the level reached in the IIS and LIS since 2002. Industrial customer demand has decreased given reductions in paper mill loads in 2005, 2008 and 2009. The reduction in industrial demand has been partially offset by gains in the residential and commercial customer classes. Peak demand has grown by 1.1% in the IIS reflecting the contribution of residential and commercial heating requirements which are a significant contributor to peak demand. Future electricity demand growth is expected in both the LIS and IIS.

The transmission system in the IIS is primarily based around a 230 kV backbone which runs from Corner Brook to the Avalon Peninsula, centered around Bay d'Espoir with many lower voltage radial circuits serving remote areas of the island. Similar to the generation assets the transmission assets are relatively old and will require investment to replace or upgrade.

Similar to the IIS, many LIS assets face issues around aging. The average age of Labrador transmission system assets is in the range of 36-40 years thus requiring ongoing capital investments to ensure reliable service.<sup>59</sup>

To address the increasing peak demand on the IIS a 123.5 MW combustion turbine was added to be available for the 2014-15 winter peak. Longer term the Muskrat Falls hydroelectric generation facility is scheduled to achieve commercial operation in 2017/18. Major new transmission facilities to deliver the energy from Muskrat Falls are also under development and these facilities will interconnect the Island of Newfoundland with Labrador for the first time and provide new interconnections to the North America grid. This raises a number of market, planning and rate and regulatory issues, which are discussed further in this report.

Average electricity rates for residential, commercial and industrial customers in St. John's are generally below the average for other jurisdictions across Canada for those customer classes. Over the past 5 years capital budgets for NLH and NP have increased at 8.4% and 7.4% respectively. Future capital expenditures will continue this trend as both utilities address capital required to refurbish and replace aging assets as well as load growth. NLH in particular is expected to see a steep increase in capital expenditures over the next 5 years as major generation and transmission investments are required to integrate Muskrat Falls and maintain reliability on the IIS. The rate impacts from Muskrat Falls will be mitigated by the capital recovery schedule reflected in the PPA between Muskrat Falls and NLH, which results in a roll-in of the costs of these facilities and a more gradual increase in rates. Under typical cost-of-service ratemaking the most dramatic rate impacts are experienced in the initial years of commercial operation and decline over time as the cost of the facilities are amortized. Where large capital projects cause significant short-term rate increases, it is common practice to spread out the impacts over a longer period of time.

---

<sup>59</sup> <http://www.pub.nf.ca/applications/NLH2013GRA-Amended/files/rfi/IN-NLH-028.pdf> ;  
<http://www.pub.nf.ca/applications/NLH2013GRA-Amended/files/rfi/PUB-NLH-084%20rev%201.pdf>

### **3. Review of Electricity Sector Legislation, Agencies with Oversight and Major Changes to Sector**

#### **3.1 Electricity Sector Legislation**

Four key pieces of legislation govern Newfoundland and Labrador's electricity sector: (1) *The Electrical Power Control Act, 1994 (EPCA)*; (2) the *Public Utilities Act (PUA)*; (3) the *Hydro Corporation Act, 2007*; and (4) the *Energy Corporation Act, 2007*.<sup>60</sup>

##### **3.1.1 The *Electrical Power Control Act***

The *EPCA* in broad terms sets the electricity policy of the province with respect to electricity rates, criteria for the production, transmission and distribution of electricity, and gives the PUB the authority to implement these policies, but with provisions for direction from the government by the Lieutenant-Governor in Council (Lieutenant Governor). In particular, the *EPCA* specifies that the rates charged to electricity customers: (i) should be reasonable and not unjustly discriminatory, (ii) should be established based on forecast costs for that supply of power for one or more years; (iii) should provide sufficient revenue to allow the producer (generator) or retailer to earn a just and reasonable return and to achieve and maintain a sound credit rating, (iv) should eliminate rate subsidies from industrial customers to rural customers, and (v) should promote the development of industrial activity in Labrador.<sup>61</sup>

While the first four objectives are relatively common and seen in other jurisdictions, this last provision is not. Legislative objectives regarding electricity rates are typically to ensure that they are just and reasonable or not unduly discriminatory, promoting industrial activity is not typical. However, with relatively limited domestic or commercial load in Labrador, there's limited potential for cross-subsidization. This objective is clearly reflected in the Labrador industrial rate policy which is reviewed earlier and this rate policy does not appear to disadvantage domestic or commercial customers.<sup>62</sup> The primary party to be affected by such a policy is government, as shareholder/owner of Nalcor and NLH. This is clearly an example of broader government policy objectives being reflected in ratemaking and the appropriate exercise of government policy discretion.

The *EPCA* also specifies that "all sources and facilities for the production, transmission and distribution of power in the province should be managed and operated in a manner (i) that would result in the most efficient production, transmission and distribution of power, (ii) that would result

---

<sup>60</sup> In addition, Newfoundland and Labrador's electricity sector is governed by the *Energy Corporation of Newfoundland and Labrador Water Rights Act, 2008* and the *Churchill Falls (Labrador) Corporation Limited (Lease) Act, 1961* which are reviewed at the end of this chapter.

<sup>61</sup> Section 3 (a).

<sup>62</sup> Specifically, the Labrador industrial rate policy provides for a Development Block, which is provided at below market prices, and a Market Block, which is priced on a market-basis reflecting the net-backed (i.e., less transmission costs) price that Nalcor would receive for sales in the New York electricity market. Section 5.8 (2) of the *EPCA* states that the *PUA* shall not apply to the setting of electricity rates for industrial customers in Labrador other than the transmission component of those rates.

in consumers in the province having equitable access to an adequate supply of power, and (iii) that would result in power being delivered to consumers at the lowest possible cost consistent with reliable service.”<sup>63</sup> In directing the PUB to implement this power policy, the *EPCA* calls upon the PUB to apply tests that are consistent with generally accepted sound public utility practice.<sup>64</sup>

The *EPCA* also provides that in the event of an emergency arising from the loss of use of generating facilities, water shortage or failure of transmission or distribution facilities an emergency controller appointed by the government should have the responsibility and authority to determine policies, allocate available power, and make provisions for the supply and distribution of power.

In addition, the *EPCA* gives the PUB authority and responsibility to ensure adequate planning by the utilities for the future production, transmission, and distribution of power in the province and to direct utilities to perform such activities and provide such information as it considers necessary under terms and conditions it may prescribe.<sup>65</sup>

The *EPCA* provides for the Government to refer to the PUB issues associated with electricity rates and more broadly any general matters related to electricity. Pursuant to Section 5.1 of the *EPCA* the Lieutenant Governor is empowered to give direction respecting the policies and procedures to be implemented by the PUB in determining rate structures for public utilities. This provision details the specific issues upon which direction can be provided, including the setting and subsidization of rural rates and the setting of industrial rates in Labrador as well as the setting of a debt-equity ratio and rate of return for NLH. Specific guidance from the government to the PUB is also provided for the following items for Muskrat Falls: (i) costs to be included in rates and other general rate-making matters; and (ii) whether or not a hearing will be held. The issues associated with providing such direction are discussed more fully in Section 6.2.

Pursuant to Section 5.2 of the *EPCA* the Lieutenant Governor is empowered to exempt a utility from the Act when it is in the best interests of the Province as a matter of public convenience or general policy. Since the mid-1990s major supply additions have typically been exempted from PUB oversight under various directives.<sup>66</sup> While these exemptions can be viewed as preventing the PUB from exercising the appropriate degree of regulatory oversight, this practice is common throughout Canada. This issue is addressed further in Section 6.2

---

<sup>63</sup> Section 3 (b) This language clearly gives the PUB authority to conduct the sort of investigation such as it has engaged in regarding the January 2014 power outages.

<sup>64</sup> Section 4.

<sup>65</sup> Section 6 of the *EPCA* states that:

“(1) *The public utilities board has the authority and the responsibility to ensure that adequate planning occurs for the future production, transmission and distribution of power in the province.*  
(2) *The public utilities board may direct a producer or retailer to perform such activities and provide such information as it considers necessary for such planning to the public utilities board or to any other producer or retailer on such terms and conditions as it may prescribe.*”

<sup>66</sup> See for example, *Granite Canal Hydroelectric Project Exemption Order* (O.C. 2000-169/170), *The Newfoundland and Labrador Hydro-Corner Brook Pulp and Paper Limited Exemption Order* (O.C. 2000-489/490), and *Muskrat Falls Exemption Order* (O.C. 2013-342).



In addition, the government can request the PUB to conduct a provincial supply and demand inquiry; declare that a state of emergency (e.g., supply shortfall or inability to deliver energy) exists or has existed; and approve regulations made by the PUB.

In 2012 to facilitate financing for the Muskrat Falls project, legislative amendments were enacted to: (1) expand the scope of the direction that the Lieutenant Governor may give the PUB regarding the Muskrat Falls project; (2) provide NLH with the exclusive right to supply and sell electricity to retailers and industrial customers in the IIS; and (3) require retailers (e.g., NP) and industrial customers in the IIS to buy electricity exclusively from NLH. These changes were reflected in amendments to the *EPCA*.

The *EPCA* provides the PUB with the authority to regulate and approve water management agreements recognizing that “all sources and facilities for the production, transmission and distribution of power in the province should be managed and operated in a manner that would result in the most efficient production, transmission and distribution of power.”

The *EPCA* also requires Nalcor Energy and CFLCo, the two power producers on the Churchill River, to use available storage and their respective generating facilities to optimize the production of power while maintaining the contractual obligations of Churchill Falls to its customers, including Hydro-Québec. The terms of the Water Management Agreement, which have already been established, require Muskrat Falls and Churchill Falls to operate as an integrated system so as to optimize and maximize output of the available water resources. This is best practice and critical to ensuring that this resource provides the greatest benefits to customers and the province.

### **3.1.2 The *Public Utilities Act***

The *PUA* sets out the structure of the PUB and defines its powers. The PUB has responsibility for the general supervision of public utilities in the Province, which requires the PUB to approve rates, capital expenditures and other aspects of the business of public utilities. To discharge these responsibilities the PUB has established an annual capital budget review process and procedures for general rate applications, both of which are reviewed in Sections 3.2.2.1 and 3.2.2.2. The *PUA* defines a public utility in the province as an entity that owns, operates, manages or controls equipment or facilities for the production, generation, storage, transmission, delivery, or provision of electric power or energy, water, heat or sewage to or for the public or a corporation for compensation. Section 118 provides that the “Act shall be interpreted and construed liberally in order to accomplish its purposes” and “the board created has, in addition to the powers specified in this Act, all additional, implied and incidental powers which may be appropriate or necessary to carry out all the powers specified in this Act.” In sum, the *PUA* and *EPCA* appears to provide the PUB with all necessary authorities to oversee the public utilities it regulates, including overseeing the reasonableness of the rates.<sup>67</sup>

---

<sup>67</sup> Like regulators in other jurisdictions the PUB has the authority to call a utility in for a rate filing, but the PUB did not do so.

### **3.1.3 Hydro Corporation Act**

The *Hydro Corporation Act* established Newfoundland and Labrador Hydro (NLH) in 1975. The *Hydro Corporation Act* provides NLH with all the rights and responsibilities required to carry on business as a Crown utility in the province of Newfoundland and Labrador.

### **3.1.4 Energy Corporation Act**

The *Energy Corporation Act* established Nalcor and granted it the rights to act as a corporation and as a Crown agency, but independent of the Crown. With respect to the Muskrat Falls project, Nalcor may operate as an agent of the Crown where the contract is approved by the government and states that it was entered into by Nalcor as an agent of the Crown, and independently of the Crown. The activities that Nalcor can carry out in the energy sector are broad and include investing and carrying out activities in all areas of the energy sector in the province and elsewhere. This includes: (1) all elements of the value chain for electric power including generation, transmission, distribution, export and purchase of power from wind, water, steam, gas, coal, oil hydrogen and other products for the generation of electricity; (2) the exploration, development, production, refining, marketing and transportation of hydrocarbons and related products; (3) the manufacture, production, distribution and sale of energy related products and services; and (4) research and development. Nalcor is allowed to engage in other activities with the approval of the government.

Under the *Energy Corporation Act*, Nalcor's Board is appointed by the government and serves at its pleasure. The *Energy Corporation Act* also provides for the appointment of the chief executive officer and a chair of the Board, responsible for the direction, supervision, and control of the board and the corporation overall by the Government. The board may appoint an acting CEO if the existing CEO is incapacitated or absent until the CEO returns, resumes duties, or another is appointed.

Nalcor is specifically exempted from the *Public Utilities Act*. The government can elect to guarantee the debt or otherwise provide a performance guarantee of Nalcor and its affiliates.

### **3.1.5 Other Ancillary Legislation**

The *Energy Corporation of Newfoundland and Labrador Water Rights Act (Water Rights Act)* terminated any pre-existing water rights in the Lower Churchill River and allowed the Lieutenant Governor to grant to the Energy Corporation (i.e., Nalcor) water rights on the Lower Churchill River. The *Water Rights Act* empowers the Lieutenant Governor to, upon the request of Nalcor, issue a license for the water rights for the Lower Churchill River to Nalcor for electricity generation.

The *Churchill Falls (Labrador) Corporation Limited (Lease) Act* authorized the Lieutenant Governor to lease to CFLCo water rights on the Churchill River and exempted CFLCo from the *PUA*.

## 3.2 Review of Agencies with Oversight over Electricity Sector

This section reviews the roles and assesses the performance of the agencies with oversight over the electricity sector including the Department of Natural Resources, PUB, and Consumer Advocate.

### 3.2.1 Department of Natural Resources

The Newfoundland and Labrador Department of Natural Resources (Department) is responsible for the stewardship and development of the province's natural resources through the Mines and Energy Branches and the Forestry and Agrifoods Agency. The Department's Energy Branch has responsibility for legislative, regulatory and policy functions related to the oil and gas and electric utility sectors.

The branch is divided into several sub-sections. The Energy Policy Section is responsible for developing, planning and coordinating legislative, regulatory and policy matters relating to the province's energy sector. The Electricity and Alternative Energy Division operates under this section, which is responsible for electricity industry governance and structure, electricity markets, alternative energy, and the *EPCA*.<sup>68</sup>

The Department works with Nalcor in policy-related areas for various energy sector activities. Areas of collaboration include issues related to the province's electricity system and the execution of key policy actions set in the 2007 Energy Plan. The Department also plays an important role vis-à-vis public information on key projects. For example, the Department had a major role in developing information regarding the role that Muskrat Falls could play in the province's electricity sector.

#### 3.2.1.1 Government Direction

As noted in Section 3.1, the *EPCA* of 1994 as amended sets policy regarding electric power rates and establishes provisions for the determination of those rates by the PUB. The role of the government is outlined in the *EPCA*. Among the responsibilities are:

- The government may direct the PUB with respect to policies and procedures for determining rate structures;
- The government may direct the PUB to implement policies, procedures and directives for the Muskrat Falls Project;
- The government may exempt a public utility from the application of all or a portion of the Act;
- The government can request the PUB to conduct a provincial supply and demand inquiry;

---

<sup>68</sup> Newfoundland and Labrador Regulation 51/08 states that the powers, functions and duties of the Minister of Natural Resources include the supervision, control and direction of all matters relating to the *EPCA*. See <http://www.assembly.nl.ca/legislation/sr/annualregs/2008/nr080051.htm>.

- The government may declare that a state of emergency (e.g., supply shortfall or inability to deliver energy) exists or has existed; and
- The government may approve regulations made by the PUB.

Since the mid-1990s major supply additions have typically been exempted from PUB oversight under various directives. While exemptions can be viewed as preventing a regulatory body from exercising the appropriate degree of regulatory oversight, this practice is common throughout Canada and reviewed below, in the Newfoundland and Labrador context. The exemptions to date provided in Newfoundland and Labrador are outlined in Table 6.

**Table 6: Exemptions from all or portion of EPCA**

<b>Exemption Order</b>	<b>Exemption For</b>
Abitibi-Consolidated Inc. and Abitibi Partner Exemption Order	Abitibi-Consolidated's 27 MW hydroelectric project redevelopment at Bishop Falls from the requirements of the <i>EPCA</i> and <i>PUA</i>
Biogas Project Exemption Order	NLH purchases of power from biogas projects under long-term PPAs from the requirements of the <i>EPCA</i> and <i>PUA</i>
Corner Brook Pulp and Paper Limited Exemption Order	Corner Brook Pulp and Paper's 15 MW biomass project from the requirements of the <i>EPCA</i> and <i>PUA</i>
Granite Canal Hydroelectric Project Exemption Order	NLH's Granite Canal Hydroelectric Project exempted from the <i>EPCA</i> and <i>PUA</i>
Labrador Hydro Project Exemption Order	NLH's planning, design and construction of generation at Churchill Falls, Gull Island, and Muskrat Falls
Labrador West Transmission Exemption Order	NLH's planning, design and construction of a 230 kV transmission line from Churchill Falls to Labrador West
Maritime Link Exemption Order	Muskrat Falls Corporation for sale of energy and capacity from elements of <i>EPCA</i> and NSP Maritime Link from various sections of the <i>PUA</i> given that it is not recovering costs from ratepayers in the province
Muskrat Falls Exemption Order	NLH from payments to Muskrat Falls Corporation and obligations as part of financing of facilities; and various entities created to design, own and operate relevant generation and transmission facilities from <i>EPCA</i> and <i>PUA</i>
Newfoundland and Labrador Hydro-Abitibi Consolidated Inc. Exemption Order, 2002	NLH from purchases of power from Abitibi's generation facilities at Grand Falls and Bishop Falls from <i>EPCA</i> and <i>PUA</i>
Newfoundland and Labrador Hydro-Abitibi Consolidated Inc. Stephenville Operations Exemption Order	NLH from all aspects of <i>EPCA</i> and <i>PUA</i> for a contract for interruptible power from the Abitibi Stephenville mill
Newfoundland and Labrador Hydro-Corner Brook Pulp and Paper Limited Exemption Order	NLH from the <i>EPCA</i> and <i>PUA</i> pertaining to purchases of power from a 15 MW biomass project at Corner Brook Pulp and Paper
Newfoundland and Labrador Hydro-Exploits Generation Exemption Order	NLH from the <i>EPCA</i> and <i>PUA</i> pertaining to purchases of power from Nalcor from the Exploits hydroelectric projects

Source: [http://assembly.nl.ca/Legislation/sr/reg\\_140.htm](http://assembly.nl.ca/Legislation/sr/reg_140.htm)

### 3.2.2 Board of Commissioners of Public Utilities

The Board of Commissioners of Public Utilities is an independent, quasi-judicial regulatory body that operates primarily under the *PUA* and *EPCA*.<sup>69</sup> Among other responsibilities relating to oversight of petroleum pricing and automobile insurance, the PUB is responsible for the regulation

<sup>69</sup> The PUB also operates under the *Hydro Corporation Act, 2007*.

of the electric utilities in the province to ensure that the rates charged are just and reasonable, and that the service provided is safe and reliable. To enable it to carry out these responsibilities, the PUB also has statutory responsibility under the *EPCA* to ensure that adequate electrical system planning occurs for the province.

The *PUA* explicitly provides for four full time Board Members including the Chair and Chief Executive Officer and Vice Chair. All are appointed by the Lieutenant Governor.<sup>70</sup> The *PUA* appropriately provides that “In making appointments [for Commissioners] the Lieutenant-Governor in Council shall take into consideration the need of the board to be composed of commissioners who have expertise in law, engineering, accountancy or finance.”<sup>71</sup> This is a best practice.

Commissioners are appointed for terms of 10 years, which when combined with staggered appointments assists in ensuring that the PUB is experienced and knowledgeable. Ten-year terms are long relative to practice elsewhere.<sup>72</sup> For example, the *Ontario Energy Board Act* provides for two years for the initial term and for up to five years for reappointments. A report reviewing governance best practices, *Guidelines for the Governance of the Electricity Sector in Canada*, recommended five-year terms, with one five-year renewal. Power Advisory doesn’t believe that the long length of terms is a major issue; it will presumably make it easier to recruit Commissioners and will enhance institutional knowledge.

We understand that the Vice Chair is very active in CAMPUT,<sup>73</sup> which provides broad exposure to other regulators and assists in staying abreast of regulatory best practices. The *PUA* gives the Chair and Chief Executive Officer full authority for the operation, management and administration of the PUB. The PUB has seventeen full-time staff and utilizes consultants to support its activities in regulatory filings.

The PUB is organized in terms of regulatory and advisory services and corporate services. As their names imply, the regulatory and advisory services section oversees the PUB’s regulatory mandate and the corporate services section is responsible for the management of the administrative functions of the PUB.

The PUB has responsibility for the general supervision of public utilities in the Province, which requires that it approve rates, capital expenditures and other aspects of the business of public utilities. With respect to the regulation of the electric utilities in the province, the PUB is responsible for ensuring that the rates charged are just and reasonable, and that the service provided

---

<sup>70</sup> The legislation in other jurisdictions that enables public utility commissions typically isn’t so prescriptive in terms of specifying the number of commissioners.

<sup>71</sup> Section 6.(3).

<sup>72</sup> However, the New Brunswick Energy and Utilities Board has ten year terms for its commissioners.

<sup>73</sup> CAMPUT is an organization of Canada’s federal, provincial and territorial regulatory bodies, which are responsible for providing regulatory oversight over the electric, gas, pipeline and water utilities in Canada.

is safe and reliable.<sup>74</sup> The PUB's processes and procedures for overseeing capital investment and rates are reviewed below.

### **3.2.2.1 Annual Capital Budget Review**

Electrical utilities are required to submit an annual capital budget for review and approval by the PUB. The annual capital budget submitted to the PUB must include any proposed improvements or additions to the electrical utility's asset base that is in excess of \$50,000 or a capital lease amount in excess of \$5,000. These thresholds were identified in our interviews with stakeholders as inappropriately low. Their appropriateness will be evaluated in section 6.2.5 of this report.

The annual capital budget review process requires electric utilities to report actual expenditures from the previous year and provide an explanation as to increases in the costs relative to the amounts approved by the PUB as part of previous capital budget submissions. The PUB has established capital budget application guidelines to provide clarity and consistency in the submission of capital expenditures while ensuring transparent and fair oversight. The capital budget application guidelines provide an outline of the application format for the electric utilities' capital budgets.

### **3.2.2.2 General Rate Application**

The PUB provides regulatory oversight of electricity rates in Newfoundland and Labrador by presiding over a general rate application (GRA) process where NLH and NP are required to submit to the PUB a GRA when they require an adjustment to their rates. A GRA is expected to justify requested changes in electricity rates and any adjustments to rate classifications. The PUA entitles electrical utilities to earn a reasonable rate of return as determined by the PUB on their approved rate base. The electric utility may also request changes to their allowed rate of return.

There is no formal schedule for the submission of GRAs by public utilities. However, the PUB can order a public utility to file a GRA. Historically, NP has submitted a GRA on a two to three year cycle to recover capital expenditures, increases in costs and any changes to general economic conditions that would affect the company's cost of capital and funding capabilities. The last GRA submitted by NLH and approved by the PUB was in 2007. Since that time NLH has continued to operate their system under the approved rates. In 2013 NLH submitted a GRA; this GRA generated an extensive number of requests for information (i.e., in excess of 1,400). Due to the anticipated timing of the PUB's final order for this GRA, NLH filed an interim rate application in November 2013 for rates to be effective January 1, 2014 until a final order is issued. A second interim rate application was filed May 12, 2014. The PUB denied or dismissed both interim rate applications. NLH submitted an amended 2013 GRA with a 2015 forecast test year on November 10, 2014. NLH filed another interim rate application with the PUB on January 28, 2015. On May

---

<sup>74</sup> The PUB also regulates auto insurance rates and insurance underwriting guidelines for the province. The PUB also sets the maximum rates for gasoline, automotive diesel, and home heating fuels and licenses ambulance and bus service providers.

8, 2015, the PUB approved interim rate increases to take effect July 1, 2015, but the increases differed from those proposed by NLH.

### **3.2.2.3 Authority for Oversight over Resource Planning**

As discussed above in Section 3.1, to enable it to carry out these responsibilities the PUB also has statutory responsibility under the *EPCA* to ensure that adequate electrical system planning occurs for the Province. With respect to resource planning the PUB has found that:

“The Board has authority and responsibility to ensure that adequate planning occurs in the production, transmission and distribution of least cost reliable power in the Province. While the Board will make no order at this time with respect to Integrated Resource Planning, the utilities may be required by the Board, consistent with its mandate, to participate in a generic process to address issues and benefits associated with Integrated Resource Planning.”<sup>75</sup>

In its review of the Muskrat Falls project, the PUB noted that it “has an explicit mandate with respect to reliability of the system as set out in s. 3(b)(iii) of the *EPCA*. While Nalcor is exempted from the *EPCA* and the *Public Utilities Act* the PUB still has a responsibility to ensure that electricity supply for the Island Interconnected System is adequately planned and operated reliably at the lowest possible cost consistent with an acceptable level of reliability.”<sup>76</sup>

As is common across Canada, the PUB operates under a policy and regulatory framework established by the government, but with distinct roles and responsibilities. In particular, the PUB’s traditional focus is least cost, whereas the government has a broader public policy focus. Regulation of a Crown utility such as NLH leads to further complexity, since the utility can be an agent for social, economic and environmental objectives in the broader public interest, which are beyond the PUB’s “lowest possible cost consistent with reliable service” focus.<sup>77</sup> These issues are discussed further in Section 6.2.

### **3.2.3 Consumer Advocate**

The Consumer Advocate is appointed by the Lieutenant Governor under the *PUA* to represent the interests of domestic and general service customers in the province. The *PUA* gives wide discretion to the Lieutenant Governor specifying that the terms and conditions of the appointment are at the discretion of the Lieutenant Governor and that all costs of the Consumer Advocate are borne by the PUB.<sup>78</sup> The Consumer Advocate represents the interest of customers in each application submitted by electric utilities before the PUB. Currently, the Consumer Advocate is appointed for a standing one-year term to represent the public interest of these customers before the PUB as the need arises

---

<sup>75</sup> Order No. P.U 14 (2004), p. 149.

<sup>76</sup> Review of Two Generation Expansion Options for the Least-Cost Supply of Power to Island Interconnected Customers for the Period 2011 – 2067, p. 100.

<sup>77</sup> An example of this, albeit imperfect because it is codified as the policy of the Province, is promoting “the development of industrial activity in Labrador”.

<sup>78</sup> Section 117.



rather than having to seek a specific appointment by Order-in-Council. The PUB has encouraged electric utilities to correspond with the Consumer Advocate as part of a pre-application process and to share information related to the nature of the application, hopefully to improve the efficiency of hearings. The general interest of the Consumer Advocate is to seek to ensure that electricity rates requested by electrical utilities are just and reasonable for domestic and general service customers. The Consumer Advocate's primary objective is to ensure these customers are properly represented during the rate setting and capital expenditure approval process.

A majority of Canadian jurisdictions don't have a formal consumer advocate including BC, Saskatchewan, Manitoba, Ontario, New Brunswick and PEI. However, most of these jurisdictions have intervener funding and organizations which represent small consumers' interests and thereby effectively satisfying the purpose of a consumer advocate.

Unlike Alberta where there's an Office of the Consumer Advocate which has a staff,<sup>79</sup> in Newfoundland and Labrador the function is provided by an individual who typically engages consultants to provide technical support. A similar approach is used in Nova Scotia. While the Consumer Advocate is appointed for a one-year term, the existing Consumer Advocate has served in this role since 2004.<sup>80</sup>

### **3.3 Changes to Electricity Sector since *EPCA* Enacted**

#### **3.3.1 Newfoundland and Labrador's Electricity Sector since *EPCA* Enacted**

There have been a number of significant changes to Newfoundland and Labrador's electricity sector since the *EPCA* was enacted in 1994. Among the most important are: (1) the commercialization and formal regulation of NLH through the *EPCA*, which effectively put NLH on a full commercial basis, with formal financial reporting and subjected it the *Public Utilities Act*; (2) the creation of Nalcor, through the *Energy Corporation Act*; and (3) the development of Lower Churchill which resulted in the *Energy Corporation of Newfoundland and Labrador Water Rights Act*. These are discussed in greater detail below, with the development of Muskrat Falls also discussed in Section 2.4.

##### **3.3.1.1 Rate Regulation of NLH under the *PUA***

One change that was initiated by the *EPCA* was that NLH became a fully regulated public utility under the *PUA*. Prior to this there were no formal PUB orders on NLH's rates, just recommendations to government who had final authority over rates. Furthermore, there was no formal regulation of industrial rates; these were set by NLH's Board of Directors.

In 2001, NLH filed its first GRA as a fully regulated utility. In the order regarding this application (Order No. P. U. 7(2002-2003)), the PUB outlined a framework for guiding the regulation of NLH.

---

<sup>79</sup> The Alberta UCA also has an important role providing information to Alberta consumers. With a competitive retail market with over 20 suppliers and 40 retail products, the UCA assembles this information to assist small consumers evaluate these offers.

<sup>80</sup> <http://www.releases.gov.nl.ca/releases/2004/just/0715n07.htm>.

This regulatory framework was consistent with that applied to NP except NLH was not allowed to earn a similar rate of return as investor-owned or other commercialized Crown-owned utilities on its assets which had the effect of keeping NLH debt higher than other Canadian utilities.

A fundamental element of these reforms was the commercialization of NLH, which included formal financial reporting. As discussed below, similar changes were made across Canada to other Crown-owned utilities.

### **3.3.1.2 The Creation of Nalcor**

The *Energy Corporation Act* was enacted in June 2007 and reviewed in detail in section 3.1.4. It established the Energy Corporation of Newfoundland and Labrador (Energy Corporation), which was to be wholly-owned by the province and to “take a lead role in the province’s participation in the development of our energy resources.”<sup>81</sup> This Energy Corporation was to be the parent company of NLH, CFLCo, and new entities created to manage the province’s investments in the energy sector. As a holding company, it provided a structure that permits both regulated (e.g., NLH) and non-regulated entities to exist and grow within separate legal entities. It ultimately was named Nalcor Energy. The creation of the Energy Corporation was one of the key initiatives of the Energy Plan, which was also released in 2007.

### **3.3.1.3 Development of Lower Churchill Project**

The development of Muskrat Falls has been discussed. In December 2012, the development of Muskrat Falls was formally sanctioned after Muskrat Falls and its associated transmission facilities were found to offer the least cost to meet the Island’s future energy requirements, with Holyrood nearing the end of its useful life and having high sulfur, nitrogen oxide and carbon emissions. Also supporting the decision to proceed with the development of Muskrat Falls was the potential for greater supply and system reliability.

Given that Muskrat Falls has relatively limited storage and is on the same river as Churchill Falls there is a need to coordinate flows on the Churchill River to maximize the value of the cumulative resource. This was the purpose of the *Energy Corporation of Newfoundland and Labrador Water Rights Act*, which gave the government the authority to issue a license granting water rights to the energy corporation and amended the *EPCA* to allow the PUB to approve a water management agreement between CFLCo and Nalcor.

## **3.3.2 Changes to North American Electricity Sector Since *EPCA* Enacted**

Since the *EPCA* was enacted in 1994 there have been a number of major developments in the North American electricity sector and many factors not currently required for PUB consideration are part of regular North American regulatory oversight. Four of the most significant are described in greater detail below: (1) the increased competitiveness of wholesale power markets and a number of

---

<sup>81</sup> Energy Plan, p. 14.

structural changes to enhance the competitiveness of these markets; (2) higher customer expectations regarding system reliability; (3) the commercialization and regulation of Crown-owned electric utilities; and (4) the promotion of renewable energy resources and increased stringency of environmental regulations.

### ***3.3.2.1 Increased Competitiveness of Wholesale Power Markets***

Since 1994 there have been fundamental changes to electricity markets worldwide to introduce greater competition into the electricity sector, including changes in wholesale electricity markets. In 1994, most customers in Canada and the United States were served by vertically integrated electric utilities which generated electricity, transmitted the electricity to customers often over long distances from large power plants on high voltage transmission facilities. As a result of cost overruns at a number of these large scale facilities, which called into question the effectiveness of cost-of-service regulation and advances in technology that made it feasible for independent developers to build smaller scale plants that could compete effectively with these larger facilities, policy makers focused on enhancing the competitiveness of wholesale power markets. Particularly in regions where prices were high and there were a number of suppliers, competition has been increasingly relied upon in wholesale and retail markets instead of traditional cost-of-service regulation.

One of the most fundamental changes was initiated by the US Federal Energy Regulatory Commission (FERC), which is an independent government agency that regulates the interstate commerce in electricity, natural gas, and oil in the US. In April 1996, FERC issued Order No. 888, a rule that effectively opened up wholesale electricity markets to competition. Order No. 888 requires transmission owners who provide transmission service to offer non-discriminatory, comparable transmission service to others seeking such services over their facilities. This often is referred to as the "open access" rule. While FERC only has jurisdiction over US investor-owned electric utilities, it induced US publicly owned and Canadian utilities to provide open access by allowing jurisdictional electric utilities to preclude access to their transmission networks to a third party if they did not offer open access (i.e., reciprocity).<sup>82</sup> The goal of Order No. 888 is to ensure that potential suppliers of electricity have equal access to the market such that transmission cannot be used to preclude access to potential buyers or sellers.<sup>83</sup>

---

<sup>82</sup> As a result, all Canadian utilities that are directly or indirectly connected to the US transmission grid are expected to offer open access transmission service or provide a transmission service that FERC finds to be comparable. No Canadian entity has ever mounted a legal challenge to what amounts to extra-jurisdictional action by FERC although reciprocity is not required under NAFTA or GATT.

<sup>83</sup> On February 15, 2007, FERC amended Order No. 888 and Order No. 888-A to ensure that "transmission services are provided on a basis that is just, reasonable, and not unduly discriminatory or preferential." The final rule was designed to: (1) Strengthen the pro forma Open Access Transmission Tariff to ensure that it achieves its original purpose of remedying undue discrimination; (2) Provide greater specificity to reduce opportunities for undue discrimination and facilitate the Commission's enforcement; and (3) Increase transparency in the rules applicable to planning and use of the transmission system.

Order No. 889 was issued by FERC at the same time and established rules governing Open Access Same-time Information Systems (OASIS) and prescribing standards of conduct. This Order required that transmission owners provide transmission customers with information regarding the availability of transmission service and the standards of conduct prevented electricity utility transmission operators from providing information to competitive affiliates that is not available to third-parties. In order to meet the data requirements of Order No. 889, utilities in all Canadian provinces, except Newfoundland and Labrador, currently have their own OASIS, an Independent System Operator (ISO), or an agreement with a contractor such as Open Access Technology International, Inc. to operate an OASIS.

In response to the requirements of FERC Order 889 and a desire to enhance the competitiveness of wholesale power markets, in a number of jurisdictions there has been a disaggregation of many elements of the electricity sector. Independent system operators were created in some markets to administer transmission tariffs and ensure non-discriminatory access to transmission service. In Ontario, Ontario Hydro was split up into a generation company, a transmission and distribution company, and an independent system operator.

These rules promoted the development of competitive wholesale electricity markets where electricity is traded as a commodity in organized markets such as described below. A major benefit of these broad electricity markets was the better integration of electricity generation resources such that there was a more efficient generation dispatch. Interestingly, this is a benefit that Newfoundland and Labrador sought to realize through the coordination of hydroelectric generation on the Upper and Lower Churchill River under the Water Management Agreement.

In 1997 through 1999, competitive wholesale electricity markets opened in New England (ISO-NE market), the Mid-Atlantic states (PJM market), and New York (NYISO market). A similar type of market opened in Ontario in 2002. While the specific rules for these markets differ, they all were based on an auction approach where the price bid by the generating resource with the highest price that was called upon by the independent system operator that managed this energy market (the market-clearing price) was paid to all generating units. These markets were designed to promote economic efficiency by providing marginal cost price signals to both suppliers and consumers. During peak periods when supply was provided by peaking units that operate relatively few hours these prices needed to also provide for the capital recovery of these generating units. The net effect was relatively high levels of price volatility (i.e., variations in price over time) that provided owners of hydroelectric units with storage capability with attractive opportunities to take advantage of these price differences by utilizing the electricity storage capability of their reservoirs.<sup>84</sup> For example, hydroelectric unit owners are able to purchase low cost electricity from these markets during off-peak hours when low variable cost generating units are setting prices and sell into these markets during peak hours when high variable cost generating units are setting prices.

---

<sup>84</sup> Experience has shown that electricity has among the highest price volatility of any commodities traded.

Nalcor affiliates use external transmission networks to sell recall power from Churchill Falls and will have additional energy available for sale after Muskrat Falls enters service. Ensuring open access to these electricity markets and addressing any reciprocity requirements in FERC Order No. 888 transmission tariffs will be important, particularly as Newfoundland and Labrador's transmission network will represent a potential pathway to other electricity markets. These issues are discussed further below.

Other related developments include increased electricity trade and the development of transmission facilities to capitalize on opportunities for such trade. For example, Hydro-Quebec built HVDC transmission interconnections with New England and New York. New Brunswick has built a second 345 kV interconnection with New England. The development of the Maritime Link is consistent with this trend.

### **3.3.2.2 Higher Customer Expectations Regarding Reliability**

Driven in part by their increased reliance on digital technologies, with the most obvious examples being computers and smart phones, residential customers are requiring higher levels of reliability. With their business reliant on technology, commercial and many industrial customers also have higher expectations regarding the reliability of electricity service.

Following the Northeast Blackout of 2003, which affected 45 million people in the US and Canada, the US government passed the 2005 *Energy Policy Act* which included provision for mandatory compliance of reliability standards to be developed by an Electric Reliability Organization (ERO) subject to FERC jurisdiction. Also in 2005 a document entitled "*Principles for an Electric Reliability Organization that can Function on an International Basis*" was developed by the joint Canada-US Bilateral Electric Reliability Oversight Group<sup>85</sup> and agreed to by the US, Canada, Provinces and Territories. A primary objective of these initiatives was to establish a reliability organization that could enforce reliability standards and reduce the risk of such widespread outages in the future. North American Electric Reliability Corporation (NERC) was the entity that was charged with this responsibility, subject to oversight by FERC and governmental authorities in Canada. NERC works with eight regional entities.<sup>86</sup> NERC regions are presented in the Figure 35.

---

<sup>85</sup> The "Bilateral Principles" document can be found under the heading "Other Publications of Interest" at <http://www.electricity.ca/industry-issues/economic/reliability.php>.

<sup>86</sup> The eight regional entities are: Florida Reliability Coordinating Council (FRCC), Midwest Reliability Organization (MRO), Northeast Power Coordinating Council (NPCC), ReliabilityFirst Corporation (RFC), SERC Reliability Corporation (SERC), Southwest Power Pool, RE (SPP), Texas Reliability Entity (TRE), Western Electricity Coordinating Council (WECC).

**Figure 35: NERC Regions**

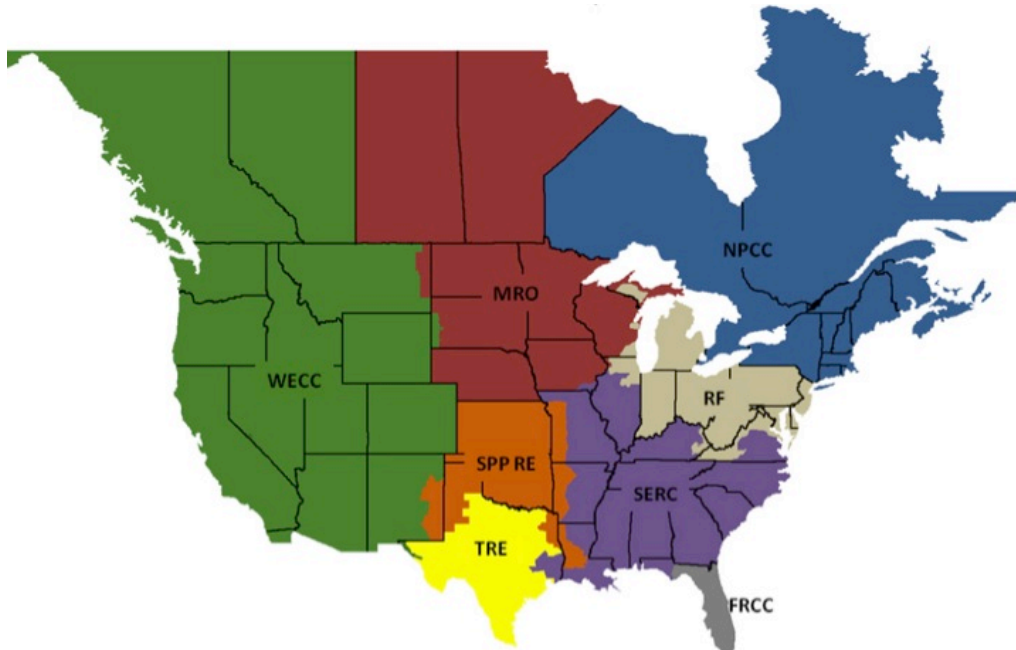

Source: NERC Website (<http://www.nerc.com/>)

As a result of the August 2003 blackout affecting Canada and the United States, most jurisdictions in Canada have adopted NERC standards as their reliability standards with modifications or exemptions as deemed appropriate by their respective regulators or standards authority. As the province is currently isolated, other than Churchill Falls' interconnection with Hydro-Quebec, reliability incidents inside NLH and NP systems do not impact the North American grid. With the development of the Muskrat Falls Hydroelectric Project (Muskrat Falls), the Island will gain two interconnection points: with Labrador by the Labrador Island Link and with Nova Scotia by the Maritime Link. However, these interconnections will be through direct current facilities. As a result Newfoundland and Labrador will not be synchronously connected with the rest of the North American grid, other than Québec given the existing ac connection between Churchill Falls and Quebec. This may have implications for NERC or NPCC compliance. These issues are evaluated further in Chapter 7.

With Newfoundland and Labrador directly connected to the North American grid, a decision will need to be made if the province will seek to comply with NERC reliability standards and if so, which standards are appropriate for it. Eight provinces within Canada have adopted NERC standards to varying degrees as their reliability standards. Similar to Newfoundland and Labrador, until recently Alberta was not directly interconnected with the US, but the Alberta Electric System Operator has adopted the mandatory use of NERC standards within Alberta. However, Alberta has decided not to enforce all NERC standards. Newfoundland and Labrador will be in a similar position and will also be connected to adjacent systems through dc converter stations, which can be

viewed as a buffer. Consideration will need to be given as to which standards are appropriate and reasonable. Applying these standards will have obvious implications for electricity system costs and system reliability.<sup>87</sup> In addition, this requires that decisions be made regarding who will administer various NERC mandated responsibilities such as rule and standards development, compliance monitoring and enforcement.

### **3.3.2.3 Commercialization and Regulation of Crown-owned Utilities**

The third major trend in Canada, which is reflected by the *EPCA*, is the commercialization and formal regulation of Crown-owned electric utilities. Similar to Newfoundland and Labrador, ratemaking oversight of crown-owned utilities in Canada since the 1980s has migrated from governments to independent regulators who typically applied traditional cost-of-service regulation principles to rate setting. As part of these changes there also was typically a move toward commercial rates of return for these utilities and often capital structures that were more reflective of what would be employed by investor-owned utilities versus the more highly leveraged Crown utilities. This move to capital structures that are more reflective of investor-owned utilities has been slow for many of these utilities given that: (1) it requires a greater reliance on equity, which is more costly than debt; (2) there are competing priorities for the required government investment or foregone dividends to realize this higher level of equity; and (3) there are significant amounts of capital investment required to replace or refurbish aging assets and this investment increases pressures for electricity rates increases.

These changes are evident in changes to Québec's electricity sector since the 1980s. Prior to December 1981, the objects of Hydro-Québec were to "supply power to the municipalities, industrial or commercial undertakings and citizens of Québec at the lowest rates consistent with sound financial administration." In December 1981 the phrase "at the lowest rates" was removed from Hydro-Québec's objects. In 2001, the Québec electricity market was further restructured by the vertical separation of Hydro-Québec into four entities: (1) Hydro-Québec Distribution who has responsibility to serve end-use customers and has a contract with Hydro-Québec Production for a set amount of supply at a fixed price, which now escalates at inflation; (2) Hydro-Québec Production who owns and operates the generation assets in the province and has a supply obligation with Hydro-Québec Distribution; (3) Hydro-Québec TransEnergie who owns and operates the transmission system; and (4) Hydro-Québec Equipement which is the prime contractor for construction projects for Hydro-Québec Production and Hydro-Québec TransEnergie. See discussion in Section 4.6.

Similarly, Ontario Hydro was disaggregated into: (1) Ontario Power Generation (OPG), a generation company that was assigned Ontario Hydro's generation assets; (2) Hydro One, a transmission and distribution company; (3) the Independent Electricity System Operator, an ISO responsible for real-time system operations and administration of Ontario's wholesale power

---

<sup>87</sup> For example, capital costs are impacted by generation and transmission system investments as the system is built to meet these standards and operating costs are impacted as the system is operated to achieve these standards.

market; and (4) Ontario Electricity Financial Corporation, a financial company assigned to pay off the stranded debt held by Ontario Hydro. (See discussion in 4.5) OPG and Hydro One are largely rate regulated and are given an opportunity to earn a return that is comparable to that realized by investor-owned electric utilities. However, as Crown-owned they are subject to provincial direction.

British Columbia and New Brunswick have followed a similar paths, with the vertical separation of different elements of the Crown-owned electric utility. Interestingly in the last several years, both BC and New Brunswick have reintegrated the various elements of their Crown-owned electric utilities to reduce corporate overheads, but have maintained the full commercial orientation of these utilities.

### **3.3.2.4 Promotion of Renewable Energy Resources and Increased Stringency of Emission Control Programs**

The fourth major trend across North America has been deliberate efforts by federal, provincial and state governments to promote the development of renewable energy resources and increase the stringency of emission controls on electricity generating units. The various policy initiatives that have been implemented have been focused on reducing the adverse environmental impacts from electricity generation and to seek to provide greater price stability to customers.

In Canada these policy initiatives include the Wind Power Production Incentive and ecoENERGY for Renewable Power programs which were administered by Natural Resources Canada, but are no longer available. In addition, many provinces (e.g., Newfoundland and Labrador, Nova Scotia, New Brunswick, Quebec, Manitoba, Saskatchewan, and BC) enabled the development of renewables by directing provincial utilities to procure renewable power or developing procurement programs such as Ontario, Nova Scotia and BC's standard offer and Feed-in Tariff programs. In the US, renewable project development has been facilitated by a federal production tax credit, which recently expired, and by programs such as renewable portfolio standards (29 states) that mandate a specific level of renewable project development.<sup>88</sup>

In addition, in Canada and the US there is a clear trend of increased stringency of emission control programs. This is evident in Nova Scotia where more stringent nitrogen oxide (requiring a 44% reduction), sulfur oxide (requiring a 75% reduction) and mercury emission caps have been imposed. Ontario has retired all of its more than 6,000 MW of coal-fired units given environmental objectives. Alberta has a program, which requires major sources to reduce their carbon emissions intensity. In addition, the US federal government has implemented numerous programs under the *Clean Air Act* that mandate significant reductions in sulfur, nitrogen oxide, and mercury emissions.

---

<sup>88</sup> These RPS programs apply to 56% of retail load in the US and will require the development of 98,000 MW of renewable energy capacity in the US by 2020. (Galen Barbose, Renewables Portfolio Standards in the United States: A Status Update Lawrence Berkeley National Laboratory, Clean Energy States Alliance Webinar November 6, 2014).



### 3.4 Summary

This chapter has reviewed the critical electricity sector legislation in Newfoundland and Labrador and reviewed the key institutions with oversight over the electricity sector. The final section focused on the significant changes to Newfoundland and Labrador's electricity sector since the enactment of the *Electrical Power Control Act* in 1994, with many of these changes in Newfoundland and Labrador mirroring changes in the broader North American electricity sector. This includes the commercialization of NLH and development of regulatory oversight by the PUB over NLH and the creation of Nalcor and its role vis-à-vis the development of the province's energy resources. With perhaps the most significant initiative for Newfoundland and Labrador's electricity sector, the development of the Muskrat Falls project.

In essence with the commercial operation of Muskrat Falls, Newfoundland and Labrador enters a new chapter for its electricity sector and with this new chapter there are a range of issues to be addressed. The issues to be addressed include:

- (1) assessing the appropriate framework and organizational structure for administering the province's transmission tariff to ensure access to export markets and to address any requirements of FERC Orders 888 and 889 as they may apply to Newfoundland and Labrador, recognizing that the province is not directly connected to the US;
- (2) re-evaluating the appropriate reliability standards and requirements for the province recognizing that with additional interconnections with adjacent markets reserve sharing will be possible, which is likely to effectively reduce the cost of achieving a higher level of system reliability;
- (3) evaluating planning, operating, and asset management practices to ensure the appropriate balance between system cost and reliability;
- (4) evaluating the role of different institutions and appropriate form of regulatory oversight for any such reliability standards; and
- (5) evaluating whether changes are needed to rate structures and demand management and conservation programs in Newfoundland and Labrador given that energy that is not consumed within the province will be able to be sold in interconnected markets.

## **4. Review of Canadian Provinces Governance, Legislation and Regulations**

To provide context for our review of the governance, legislation and regulation of Newfoundland and Labrador's electricity market, in this chapter we review for each of the Canadian provinces the structure of their electricity sector; the key enabling legislation; roles, responsibilities, and practices of electricity sector institutions; and major reforms to their electricity sector to enhance its effectiveness and achieve efficiencies. We focus on Canadian provinces given they have ownership and market structures, legislation and regulatory frameworks that are the most similar to those in Newfoundland and Labrador. The U.S. doesn't have the equivalent of Crown utilities and electricity markets in Australia and Europe are largely competitive, with significantly different electricity sector institutions and practices.

### **4.1 British Columbia**

British Columbia's electricity market structure is relatively similar to Newfoundland and Labrador's. BC Hydro, a predominately hydroelectric vertically integrated electric utility, is Crown-owned.

There is a relatively large investor-owned utility that serves a portion of the province and is owned by Fortis, operating as Fortis-BC. BC Hydro has about 1.8 million customers and in its most recent fiscal year had sales of 53 million MWh. FortisBC serves over 110,000 customers and owns about 800 MW of hydroelectric capacity. Both BC Hydro and FortisBC are regulated by the British Columbia Utilities Commission (BCUC). BC Hydro also purchases about 16.6 million MWh per year from BC independent power producers.

BC Hydro is also pursuing the development of a major hydroelectric project, Site C, on the Peace River in northeast BC. Site C was approved by the province in December 2014 and will provide 1,100 MW of capacity and about 5.1 million MWh of energy per year.

BC Hydro has a wholly owned energy trading subsidiary, Powerex, which sells BC Hydro's surplus energy into export markets. Powerex's net income has ranged from \$8 to 244 million in the five previous fiscal years; in 2014 it had a net loss of \$61 million as a result of a settlement of litigation associated with trading practices in the Western US in 2000-01. Powerex's 2014 net income prior to the settlement was \$155 million, on trade revenues of \$1,073 million and total electricity sales of 25 million MWh. By comparison, in 2013 and 2014 BC Hydro's net income was \$509 and \$549 million. Clearly, Powerex makes a significant contribution to BC Hydro's profitability.

However, there are some major differences with Newfoundland and Labrador: BC is well interconnected to the Pacific Northwest and to Alberta. In addition, BC Hydro has had an Open Access Transmission Tariff (OATT) since the US Federal Energy Regulatory Commission

established this as a requirement for direct access and participation in US power markets. BC restructured its electricity market in 2003.

At this time the British Columbia Transmission Company (BCTC) was established as a separate entity from BC Hydro to plan, build, operate and maintain BC's transmission infrastructure. Specifically, in July 2003, consistent with policy set out in the 2002 Energy Plan, the *Transmission Corporation Act* created the BCTC. At this time there was movement towards vertical separation of the generation and transmission businesses and the development of regional transmission organizations (RTOs) to enhance the competitiveness of wholesale electricity markets in North America.<sup>89</sup> With much of the transmission infrastructure in the Pacific Northwest owned by a relatively few companies, in particular the federally owned Bonneville Power Administration, the development of RTOs never occurred. In 2010, BCTC was integrated back into BC Hydro as part of the *Clean Energy Act*, which focussed on BC becoming a leading supplier of renewable energy.

As part of these restructuring initiatives, the legislature also enacted the *BC Hydro Public Power Legacy and Heritage Contract Act*. This Act provides legislative protection for BC Hydro's 'heritage assets', which include its electrical generation, storage reservoirs, and transmission and distribution systems, by ensuring that they remain publicly owned. The Act also provides the regulatory framework for the Province to establish a heritage contract to ensure that BC Hydro ratepayers continue to benefit from the low cost electricity produced by these heritage assets. The heritage contract ensures that the electricity generated by the heritage resources continues to be available to BC Hydro ratepayers based on cost of service, not market prices. BC Hydro's rates under the heritage contract were reviewed and approved by the BCUC.

The BCUC also has authority to adopt electricity system reliability standards for the province. The BCUC developed regulations, which describe the parties subject to adopted standards and giving it the power to impose penalties for contravening them. BCUC initiated an inquiry into Mandatory Reliability Standards (MRS) in October 2012 in anticipation of NERC requirements and the need to implement a new "bulk electric system" definition. Some stakeholders have suggested the BCUC lacks the capacity to regulate and monitor mandatory reliability standards, while BC Hydro has the resources and expertise but does not want to incur additional costs, risks, or responsibilities. These stakeholders note that "a greater role in ensuring MRS are met aligns with BC Hydro's multiple roles in transmission planning, development, ownership, grid operations and balancing. In addition, MRS coordination would leverage BC Hydro's institutional expertise in ensuring grid reliability for the vast majority of the Provincial Bulk Electric System."<sup>90</sup>

#### **4.1.1 Legislative Review**

This section reviews the key electricity related legislative initiatives in BC. This includes: (1) *Hydro and Power Authority Act*; (2) the *Utilities Commission Act*; (3) the *Clean Energy Act*; and

---

<sup>89</sup> Hydro-Quebec was vertically disaggregated as discussed in Section 2.6 in roughly this time frame.

<sup>90</sup> *Independent Review of the British Columbia Utilities Commission*, Interim Report, October 1, 2014.

(4) the *Ministry of Energy and Mines Act*. Other important legislation which was discussed above in the context of the restructuring of BC's electricity sector is: (1) *BC Hydro Public Power Legacy and Heritage Contract Act*, which ensured that rates in BC would be largely based on cost-of-service rather than market-based; (2) the *Transmission Corporation Act*, which was effectively repealed as it created the BCTC, which has since been rolled back into BC Hydro.

The *Hydro and Power Authority Act* sets out the role and responsibilities of BC Hydro and provides the government with broad discretion over BC Hydro through regulations. This power is widely exercised.<sup>91</sup> In addition, the government issues a "Letter of Expectations", which describes the relationship between BC Hydro and the Province and sets out objectives for BC Hydro given the government's role as shareholder. The letter is reviewed annually and updated as required and represents a clear articulation of accountabilities, roles and responsibilities of BC Hydro and the government. The 2013-14 Letter was five pages and outlines BC Hydro's accountabilities, which include service plans that outline specific performance measures and targets for those measures, and the government's responsibilities.<sup>92</sup> The service plan is submitted to the legislature and developed under the direction of BC Hydro's Board. It outlines specific service targets for safety, reliability, customer satisfaction, environmental and financial performance, and employee engagement.

The *Hydro and Power Authority Act* establishes a Board of Directors (Board), which is appointed by the Government and sit at its pleasure. The Board is charged with ensuring that there is a strategic and business planning process and then reviewing, validating and endorsing a strategy for the Corporation and monitoring its implementation. The Board is also responsible for having a continuing understanding of the principal risks associated with the Corporation's business and ensuring that the appropriate processes and systems are in place to mitigate that risk.

The *Utilities Commission Act* outlines the roles and responsibilities of the BC Utilities Commission. Commission members are appointed by the government after a merit-based recruitment and selection process, with Commissioners other than the Chair appointed after consultation with the Chair. The government may provide direction to the Commission. Section 5 of the Act requires the BCUC, on Cabinet's request, to provide advice on any matter regardless of whether it is in the Commission's jurisdiction. Section 5 also allows Cabinet to issue Terms of Reference for an inquiry to be conducted by the Commission.

The *Utilities Commission Act* requires public utilities to maintain their property and equipment so as to provide "a service to the public that the commission considers is in all respects adequate, safe, efficient, just and reasonable."<sup>93</sup>

Public utilities have a duty to provide information to the Commission, allowing the Commission to request information needed to perform its functions. The *Utilities Commission Act* requires the

---

<sup>91</sup> As a point of reference, since 2010 the Government has issued almost 8 electricity related directives a year.

<sup>92</sup> <https://www.bchydro.com/content/dam/BCHydro/customer-portal/documents/corporate/accountability-reports/openness-accountability/governments-letter-of-expectations.pdf>.

<sup>93</sup> Section 38.

Commission to ensure that a rate is not “unjust, unreasonable, unduly discriminatory or unduly preferential rate for a service provided by it in British Columbia”<sup>94</sup> and “the commission must have due regard to the setting of a rate that ... encourages public utilities to increase efficiency, reduce costs and enhance performance” and “the commission may use any mechanism, formula or other method of setting the rate that it considers advisable, and may order that the rate derived from such a mechanism, formula or other method is to remain in effect for a specified period”.<sup>95</sup> Figure 36 reviews the shareholder and regulatory relationships for BC Hydro.

**Figure 36: BC Shareholder and Regulatory Relationship Framework**

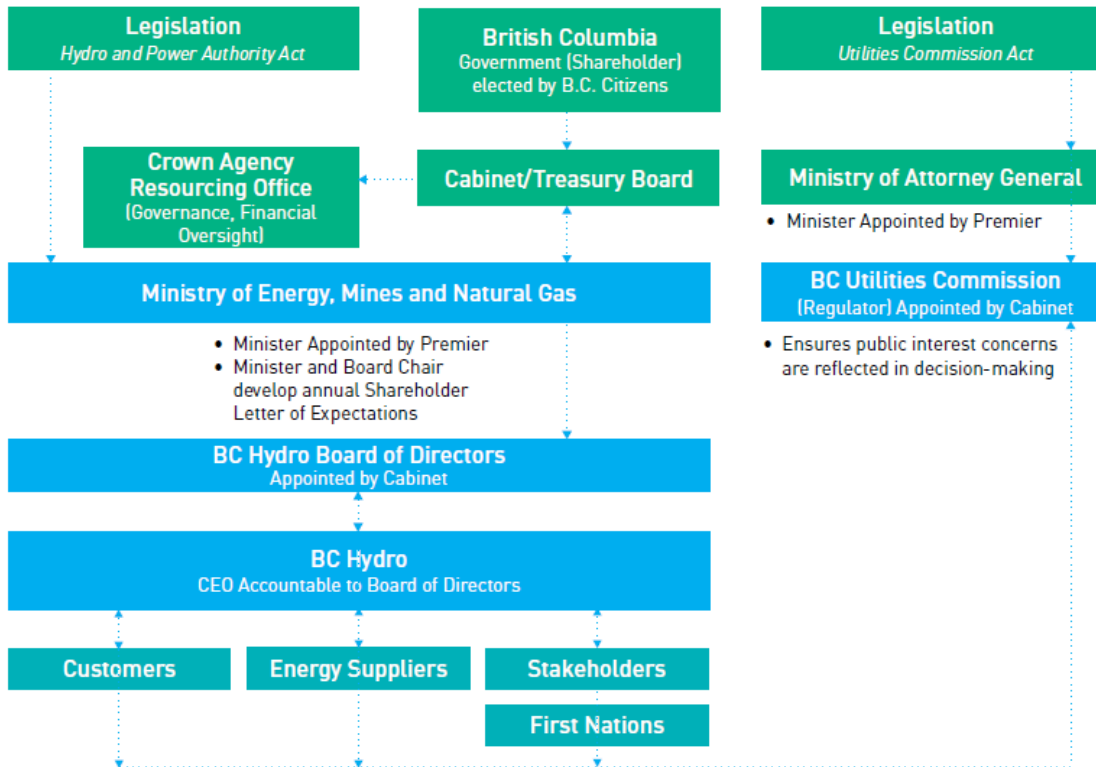

Source: BC Hydro, Annual Report

The *Clean Energy Act (CEA)* was enacted in 2010. It exempted many major projects, programs, contracts and expenditures from Commission oversight and moved approval of BC Hydro’s Integrated Resource Plan from the Commission to Cabinet. In addition, it called for:

1. The Province to achieve electricity self-sufficiency by 2016, plus 3,000 GWh of insurance by 2020;<sup>96</sup>

<sup>94</sup> Section 59.

<sup>95</sup> Section 60.

<sup>96</sup> As discussed below, the BC Hydro Review panel recommended that this commitment be relaxed.

2. 66% of projected load growth to be satisfied by demand-side management (DSM) or energy efficiency programs;<sup>97</sup>
3. A clean and renewable energy target of 93%;<sup>98</sup>
4. The Province to become a net exporter of electricity from clean and renewable resources, with BC Hydro being the aggregator and with matters regarding exports being exempt from BCUC regulation;
5. BC Hydro to deliver comprehensive Integrated Resource Plans to Cabinet (rather than the BCUC), every 5 years;
6. The re-integration BCTC with BC Hydro;
7. A feed-in-tariff for emerging technologies (i.e., ocean and others to be prescribed);
8. Revamping of the Standing Offer Program of small renewable energy projects; and
9. BCUC “must consider and be guided by” the CEA objectives.

The *CEA* was initially viewed as relatively sweeping legislation, which called for a renewed focus on renewable energy investment in BC and introduced the concept of renewable project development for export markets and exempted such projects from BCUC oversight. However, implementation of the Act has been relatively modest and its aggressive promise has not been realized. This can be attributed in part to a fundamental change in the promise offered by renewable energy development since 2007, when this BC Energy Plan goal was first identified, relative to today. In 2007, and to a lesser degree in 2010, it was conceivable that BC’s significant renewable resource potential could be profitably developed to address the growing demand for renewable energy in the Pacific Northwest and California. Furthermore, there is now relatively low cost surplus energy available in export markets which can be purchased at lower cost than developing new renewable generation resources. Furthermore, the BC Hydro review called on the government to relax the objective of the province becoming self-sufficient by 2016 to mitigate its adverse rate impacts. In addition, many of the aggressive objectives outlined in the Act have proven to be costly (e.g., having the province be largely energy self-reliant and relying on conservation to reduce load growth by 66%). This shows the risks of codifying such objectives in legislation. For example, specifying in legislation that 66% of projected load growth be satisfied with DSM or energy efficiency prevents an objective assessment of what level of investment in such programs is most cost-effective and in the best interests of electricity customers.

The *Ministry of Energy and Mines Act* outlines the purpose and functions of the Ministry of Energy and Mines (MEM or Ministry). MEM’s responsibilities include:

- The development of energy policy and regulations;
- Research on energy facilities and future energy requirements; and
- The collection and circulation of information that relates to energy resources including electricity, petroleum products and natural gas.

---

<sup>97</sup> The Industrial Electricity Policy Review Report recommended that this 66% target be removed and that DSM be procured where cost-effective.

<sup>98</sup> Clean or renewable is defined as “biomass, biogas, geothermal heat, hydro, solar, ocean, wind or any other prescribed resource.”

The Ministry also administers certain acts and regulations associated with efficient use of energy including electric power, such as the *Energy Efficiency Act*. Other electricity and alternative energy sector duties include:

- Oversight of and policy direction of two energy related Crowns:
  - BC Hydro, and
  - Columbia Power Corporation;
- Management of the Columbia River Treaty operations and downstream power benefits; and
- Participation in environmental assessment reviews of electricity projects.

#### **4.1.2 BC Hydro Review**

With significant investment required for refurbishment of its electricity system and to meet growing demand, there have been increasing pressures on BC Hydro's rates. On March 1, 2011, BC Hydro filed an application with the BCUC, seeking approval for rate increases of 9.73% for each of the next three years. BC Hydro had a 6.11% rate increase the prior year. Given the magnitude of the requested increases government requested a review of BC Hydro in order to provide recommendations and options for minimizing the rate increase by achieving cost reductions. The fact that government called for such a review after BC Hydro filed the rate increase request with the BCUC is an indication of the independence of BC Hydro.

The review examined the governance structure of BC Hydro, the business planning process and a series of areas critical to BC Hydro's financial performance, including forecasting, procurement of goods and services, general operating costs, capital assets and the rate structures themselves. The review also examined a number of key initiatives underway within BC Hydro and the impact of government policy on the effective operation of BC Hydro. As a result of the four month review, the Province and BC Hydro agreed to ask the BCUC to lower the proposed annual rate increase of 9.73 per cent a year for three years to an eight per cent increase, followed by a 3.9 per cent increase for each of the following two years,<sup>99</sup> reducing the cumulative impact of the proposed rate increases by almost 50 per cent.

BC Hydro was to achieve the reduction by lowering its expenditures by more than \$800 million over three years in the areas of operating costs including a downsized workforce, deferred capital expenditures and changing the amortization period for demand-side management programs. In the area of policy, the panel recommended the Province and BC Hydro evaluate alternative definitions and timelines for government's self-sufficiency policy, which requires BC Hydro to obtain sufficient electricity supply from sources within British Columbia by 2016. The panel also recommended: (1) accelerating the pace and magnitude of change within BC Hydro to develop an organizational structure that keeps costs down and as the economy improves; (2) working collaboratively with the Province to re-define the water rental rates charged to BC Hydro and determine a capital structure and dividend policies that balance the needs of the Province.

---

<sup>99</sup> The third year increase of 3.9% was ultimately reduced to 1.44%.

### 4.1.3 Industrial Electricity Policy Review

Continuing concerns about rising electricity costs, the suitability of BC Hydro's industrial tariff,<sup>100</sup> and various other matters pointed to the need for a systematic evaluation of BC industrial electricity rates policy and broader electricity policy issues. In January 2013, the Minister of Energy, Mines and Natural Resources appointed a task force to review the current industrial electricity policy and legislative framework, and advise Government on changes that may be required to achieve provincial policy objectives. In October 2013 the task force submitted its final report to Government. The task force offered a number of recommendations focused on policy changes, process changes, rate design and other issues. Those recommendations that are particularly relevant for Newfoundland and Labrador are reviewed below.

The task force noted that the policy direction provided by Government was confusing. For example, the *Clean Energy Act* outlined 16 provincial energy objectives to guide BCUC decisions covering issues such as rate competitiveness, economic development, GHG reductions, and clean or renewable electricity requirements. In many instances these objectives competed and made it more difficult for the Commission to fulfill its legislative mandate. Many were very prescriptive including, reduce BC Hydro's forecast load growth by 66% through conservation and energy efficiency programs and generate at least 93% of the Province's electricity supply from domestic clean or renewable energy sources by 2016.

In general, the task force recommended that the province avoid prescribing specific rules and focus on desired outcomes (e.g., pursue all cost-effective conservation, as measured by the cost of new supply). With respect to process changes they noted that government use of directives to drive public policy had increased dramatically and that this has had the effect of decreasing the effective level of public scrutiny and created controversy around BC Hydro's procurement and capital investments. To address this the task force recommended that the government adopt four additional principles beyond the regulatory compact.<sup>101</sup> These included: (1) clearly articulated policy: with the government specifying the public interest and set clear and understandable policy objectives; (2) allocating risk: utility owners make decisions based on an evaluation of risks, with the costs and benefits allocated to the party taking the risk; (3) market-based solutions: market-based solutions should be employed where possible;<sup>102</sup> and (4) public scrutiny of costs and benefits: allow ratepayers to have an opportunity for public review of any major policy-driven initiatives. The task force also recommended that the provision in the *Clean Energy Act* that called for the review of BC Hydro's IRP by government be revised to provide for review by the BCUC. In addition, the Task Force also recommended that an independent review be undertaken of the BCUC.

---

<sup>100</sup> Industrial sales account for about 32% of BC Hydro provincial sales.

<sup>101</sup> The regulatory compact allows a utility to earn a fair return on investments in return for providing reliable service at cost-based rates.

<sup>102</sup> Interestingly, this principle conflicts with the underlying notion of the regulatory compact, which is predicated on cost-of service based-rates.



#### 4.1.4 BCUC Review

In April 2014, the government announced a review of the BCUC as part of its Core Review process, with an objective of improving the BCUC's effectiveness and efficiency.<sup>103</sup> The review of the BCUC responded to concerns, raised by customer groups and utilities, about the commission's ability to deliver clear and timely decisions. In recent years, the number of information requests and the cost of funding interveners in commission proceedings has increased dramatically, resulting in additional costs and delays. As a result of the BC Hydro review process and government efforts to manage rate increases, in March 2014, the government issued orders to BC Hydro and the BCUC to implement the 10 Year Rate Plan for BC Hydro, setting rate increases and then rate caps until April 2019. After which the BCUC will have authority to oversee BC Hydro's rates.

In the interim report, the independent task force charged by the BC government to undertake this review noted that the BCUC's job has been complicated by direction from the government. Citing the *Clean Energy Act*, which introduced sixteen provincial energy objectives to guide Commission decisions, stakeholders noted that government policy goals have been ambiguous and sometimes even conflicting. The task force noted that stakeholders do not question the legitimate role of government in setting energy policy and seeing that it is implemented, however they overwhelmingly favour the government limiting itself to setting the broad policy framework and letting the Commission determine, or at least recommend, specific outcomes.

The Task Force made seven key findings:<sup>104</sup>

1. It is the provincial government's prerogative to set provincial energy policy, to define the Commission's mandate, and to direct the Commission on specific matters. However, some directions go beyond articulating the policies that the BCUC is obligated to advance, by prescribing detailed instructions to the Commission on matters that would, under normal circumstances, be left to the Commission to determine. In the future, government should delineate policies to the Commission clearly, and in advance of Commission processes, then leave the Commission to act independently within its mandate.
2. The existence of an independent expert Commission is more important than ever today. By regulating monopolies the BCUC provides an essential public service. Unfortunately the Government and key stakeholders have less confidence in the BCUC than in the past. Rectifying this requires restoring the Commission's independence within its mandate and increasing the Commission's expertise and credibility.
3. The Commission needs to be strengthened, and be seen to be strengthened. In order to make the Commissioner's role attractive to a broader range of candidates, there needs to be more full-time Commissioners, better pay and longer terms. All appointees to the Commission must bring recognized relevant expertise to the Commission. The Commission Chair needs

---

<sup>103</sup> At the same time the government announced an industrial rate design review to help identify opportunities to provide large industrial customers with more flexible rate options to manage their costs and stay competitive. It will also evaluate current industrial, commercial and residential rate structures to ensure they support key objectives including energy conservation and fairness.

<sup>104</sup> See *Independent Review of the British Columbia Utilities Commission*, Interim Report, October 1, 2014.

to be actively involved in identifying required expertise, recruiting and selecting new Commissioners.

4. The Commission staff needs to be strengthened. This requires the appointment of an Executive Director or Chief Operating Officer with general oversight responsibilities, higher salary ranges to allow the Commission to be competitive with those it regulates, and more training for existing staff.
5. Commission review processes should be improved. Where appropriate, the Commission should do more in the early scoping of hearings, vetting who has standing to appear, reviewing the relevance of staff information requests, and using its staff and counsel in the drafting of decisions. The Commission should also set and publicly report on a number of performance goals including, most importantly, the overall time between receiving an application and issuing the decision, and the time between the close of evidence and issuing the decision.
6. Crown corporations present unique regulatory challenges. BC Hydro and Insurance Corporation of British Columbia (also regulated by the Commission) are significant corporate entities in the British Columbia economy. Their sole shareholder is the Province. Governments must balance their many responsibilities in this area: owner, policy setter and regulator (through regulatory agencies). While in theory all regulated bodies should be treated the same, the reality is that in many jurisdictions, the regulatory model for Crown corporations is applied differently. If carefully designed, such modifications need not violate the independence of the regulator in carrying out its mandated responsibilities.
7. Solutions to most of the Commission's challenges do not require legislative or regulatory changes. Rather, they involve clarity of the governance model, changes to BCUC management and structure, and regulatory process improvements.

## **4.2 Alberta**

Alberta was one of the first jurisdictions in North America to restructure its electricity sector and has the only truly competitive wholesale power market in Canada. Given this market structure there are a number of aspects of Alberta's electricity market that are not directly relevant to Newfoundland and Labrador. This review focuses on those elements that are relevant.

Historically, Alberta had three major vertically integrated electric utilities which owned and operated about 90% of the province's generation, one of which was municipally owned and the other two investor-owned. Recognizing the benefits from integrated dispatch of their systems, these utilities began dispatching their generation as an integrated system. In 1995, the Alberta Power Pool was established and a framework for dispatch of generation resources within the province based on their offers was initiated in 1996.

In 1998 legislation was enacted to open both the province's wholesale and retail markets to competition. The Alberta wholesale and retail markets opened on January 1, 2001. Since this market opening there have been a series of ongoing reforms to the Alberta's wholesale and retail electricity markets including changes to the various key institutions. With a competitive wholesale power market, considerable attention was devoted to ensuring the performance of that market. One of the best measures of the effectiveness of a competitive wholesale market is the degree to which it

has promoted new generation investment. Since 1998 Alberta has had generation capacity additions of over 7,800 MW, with total capacity of 14,598 MW.

#### 4.2.1 Major Electricity Sector Institutions

The major institutions in the Alberta electricity market are the Alberta Electric System Operator (AESO), Alberta Department of Energy (Alberta Energy), Alberta Utilities Commission (AUC), the Utilities Consumer Advocate (UCA), the Market Surveillance Administrator (MSA), and the Balancing Pool.

The AUC is the regulator and as such sets rates for transmission and distribution charges. It is also responsible for overseeing the rate for the Regulated Rate Option, which is available to all residential, farm and small commercial customers that don't elect to be served by a competitive supplier. The AUC also is required to approve construction, connection and operation of new transmission facilities in Alberta. The *Hydro and Electric Energy Act* gives the AUC authority to approve the construction of transmission and generation facilities.

The AUC establishes mandatory requirements and standards of practice for the retail electric and natural gas markets through the use of a rule-making procedure involving a consultative process with stakeholders and interested parties and extensive research on current and emerging issues. The AUC has a number of rules; of particular relevance is Rule 002. In December 2003, the AUC's predecessor, the Alberta Energy and Utilities Board, issued Directive 002 for owners of electricity distribution systems. This directive established minimum performance standards of service quality and reliability for electricity distributors and facilitated the monitoring of performance in relation to those standards.<sup>105</sup> Appropriately the performance standards for a number of metrics vary by utility recognizing their differences. Rule 002 provides a reporting process for distributors to enable the distributor to monitor performance.

The AESO is responsible for the economic planning and operation of the Alberta Interconnected Electric System. The AESO has responsibility for planning the transmission system and under the Government's Transmission Regulation is charged with planning for a system that avoids congestion during normal operating conditions. The AESO contracts with transmission facility owners to acquire transmission services; develops and administers transmission tariffs; acquires ancillary services to ensure system reliability; manages settlements of the hourly wholesale market (power pool) and transmission services. The AESO must operate the power pool in a manner that is fair, efficient and open to all market participants. The AESO has established rules which outline the practices, policies and procedures that are expected from market participants. The AUC however, oversees the AESO's rule making process and adjudicates the enforcement of these rules.

Alberta Energy is the policymaker and focused on promoting the development of Alberta's portfolio of energy resources. Alberta Energy provides direction to other energy agencies through

---

<sup>105</sup> <http://www.auc.ab.ca/acts-regulations-and-auc-rules/rules/Pages/Rule002.aspx>

acts, regulations and policy statements. Alberta Energy is focused on ensuring a “reliable supply of competitively priced electricity.”

The Utilities Consumer Advocate (UCA) represents small consumers before the AUC and works to ensure that they have the information, representation and protection they need to better equip them to make informed choices in Alberta's deregulated electricity and natural gas markets. The UCA also represents consumers' interests before the AUC.

Market Surveillance Administrator (MSA) is responsible for ensuring that Alberta's electricity and retail natural gas markets operate in a fair, efficient and openly competitive manner. The MSA has access to confidential market data and closely monitors market outcomes. It uses a variety of approaches to promote effective competition and a culture of compliance by market participants with market rules and reliability standards. These range from educational and guidance material, to investigations and enforcement actions before the Alberta Utilities Commission that can lead to substantial financial penalties for contraventions. The MSA also works with Alberta Energy and the AESO to promote market frameworks and structures that support fair, efficient and openly competitive markets.

The Balancing Pool manages the financial accounts arising from the transition to a competitive generation market on behalf of electricity consumers; and meets any obligations and responsibilities associated with both sold and unsold Power Purchase Arrangements.

#### **4.2.2 Transmission Infrastructure**

Alberta has import and export capability with British Columbia to the west, Saskatchewan to the east and Montana to the south. There is a 500kV circuit and two 138 kV circuits interconnecting BC with Alberta. The path is rated at 1,000 MW for export and 1,200 MW for import. The actual current operating limit is only 750 MW due to current system constraints and this is before consideration of the Montana-Alberta Tie Line (MATL). In September 2013 a new merchant intertie between Montana and Alberta (MATL) was energized. It is the first direct interconnection to the US for Alberta's electricity system. The import/export capability for this facility is rated at 300 MW and is expected to primarily import electricity into Alberta from Montana. Alberta's interconnection with Saskatchewan is a direct current (dc) connection with an operating limit of 153 MW.

Given the Alberta electricity market's relatively small size and the challenges that this poses to achieving a workably competitive market, policymakers were very focussed on ensuring that transmission investment didn't constrain generation development or its ability to access the market. This perspective was first embodied in the Transmission Regulation, which outlines the required framework for transmission system planning, including criteria for determining when additional transmission is needed. The AESO must plan a transmission system that, in addition to satisfying reliability standards, is sufficiently robust to allow transmission of 100% of anticipated in-merit

energy when all transmission facilities are in service and 95% of all anticipated in-merit energy under abnormal operating conditions.

The concept of critical transmission infrastructure (CTI) was introduced in 2009. Under Bill 50, the *Electric Statutes Amendment Act*, 2009, Cabinet would have the right to designate certain transmission infrastructure as CTI and facilities designated as CTI would not be subject to AUC review of the need for the facility, as is otherwise mandatory for new facilities. The object was to ensure that the development of these critical transmission facilities wasn't frustrated by uncertainties regarding the future need for the facilities and the appropriate timing for the facilities. However, the designation of facilities as "critical" proved to be controversial given that it would avoid having to demonstrate the need for the facility. Upon her election in October, 2011, Premier Redford stopped hearings into the Western Alberta Transmission Line and the Eastern Alberta Transmission Line, and appointed an expert panel to review the need for those two facilities. The expert panel reported back in February, 2012, and recommended that the two facilities proceed. They are currently under construction. It also recommended that the *Electric Utilities Act* should be amended to grant the AUC (not cabinet) the authority to designate CTI.

In 2012 Bill 8 effectively removed the concept of CTI from the *Electric Utilities Act*. As a result all new transmission projects will be subject to a needs review by the AUC. Existing projects already designated in the schedule to the Act (about four major projects) remained designated as CTI and will not be affected by the amendments.

The *Alberta Utilities Commission Act* separated the Energy and Utilities Board into the Alberta Utilities Commission, which is responsible for regulating Alberta's electricity and natural gas transmission and distribution companies, and the Energy Resources Conservation Board. For applications to construct or operate power plants or transmission lines the AUC assesses whether construction or operation of the proposed facility is "in the public interest, having regard to the social and economic effects of the development ... on the environment."<sup>106</sup> With a competitive wholesale electricity market and generation investments underwritten on the basis of the value from future electricity sales, there's no formal regulatory requirement for integrated resource planning. However, the AESO does prepare a long-term plan to assist with determining what transmission investment will be required in order to avoid transmission congestion under normal operating conditions.

The *Alberta Utilities Commission Act* also spells out the responsibilities of the MSA, which include evaluating whether the conduct of electricity market participants supports the fair, efficient and openly competitive operation of the electricity market.

Under the Transmission Regulation, the AESO is responsible for adopting or making reliability standards, but is obligated to consult with market participants and these reliability standards must be submitted to the AUC for approval or rejection. The AESO's approach has been largely to adopt

---

<sup>106</sup> Section 17(1).

North American Electric Reliability Corporation (NERC) reliability standards as Alberta Reliability Standards. This approach involved a detailed review of the standards by subject matter experts and carrying out extensive stakeholder consultation prior to making a recommendation and seeking approval from the AUC. Many reliability standards have already been adopted for the Alberta region. In some instances it is determined that none of the requirements in a specific NERC standard applies to any market participants in Alberta or the AESO. The AESO then makes a recommendation to the AUC to not adopt these standards. The AUC approval must follow the AESO recommendation unless it finds the standard technically deficient, or not in the public interest.

#### **4.2.3 Market Reforms**

A considerable focus of the recent electricity sector reforms has been Alberta’s retail electricity market. While virtually all industrial and large commercial customers are supplied by competitive suppliers, almost 60% of residential customers are on a default rate which is provided to customers that don’t elect a competitive supplier. Many of the electricity retail sector reforms and market reviews have focused on issues associated with the provision of this service.

Another major area of focus has been transmission development. As discussed, Alberta has a Transmission Regulation which guides the development of new transmission and causes the AESO to seek to avoid transmission congestion. This has resulted in a dramatic increase in the amount of transmission investment and significant increases in transmission charges. This has caused the Alberta government to establish a Transmission Facilities Cost Monitoring Committee and a Transmission Cost Recovery Subcommittee. While much of the increase in transmission costs is directly attributable to the previous lack of transmission investment and the “permissive” investment criteria contained in the Transmission Regulation, there have been a number of instances where facility costs increased dramatically and this caused stakeholders to search for answers. These committees were the response to these concerns.

### **4.3 Saskatchewan**

SaskPower is a crown-owned electric utility that serves Saskatchewan, serving over 490,000 customers. In addition, to SaskPower there are two municipally owned electric utilities in Saskatoon and Swift Current.

SaskPower’s beginnings are similar to NLH’s – to develop a provincial power system and realize the economies associated with integrating small separate systems. It was founded by an Act of the provincial legislature as the Saskatchewan Power Commission in 1929. The purpose of the Commission was to determine how best to create a provincial power system which would provide the province’s residents with safe, reliable electric service.

SaskPower operates three coal-fired, seven hydroelectric, six natural gas-fired and two wind facilities, with a total capacity of 3,428 MW. This capacity is supplemented by various long-term contracts with Independent Power Producers (IPPs), which provide 853 MW.

Reflecting the underlying strength of the provincial economy, the electricity requirement of SaskPower's customers have been growing rapidly, with energy sales growing by 6.4% from 2012 to 2013. Annual growth averaged 3.3% from 2010 to 2013. A major contributor to this growth has been industrial customers, with SaskPower's 100 largest customers representing 40% of its total energy requirements. Therefore, changes in the requirements of these customers can have a significant impact on its overall energy requirements.

In response to this growth and the aging of its existing infrastructure, SaskPower is engaged in a multi-billion dollar investment program, which calls for annual investment of about \$1 billion per year. With a net capital plan of about \$8 billion, this represents about a 12% increase in net capital in the first year. This new investment includes the Boundary Dam Integrated Carbon Capture and Storage Demonstration Project, the first commercially viable large-scale carbon capture and storage project at a coal-fired power plant. As a result of these investment requirements, SaskPower's long-term debt is expected to increase from \$3.6 billion at the end of 2013 to \$7.6 billion by the end of 2016.<sup>107</sup>

SaskPower has relatively limited interconnections with Manitoba, Alberta and North Dakota, which provide 250 MW, 75 MW, and 140 MW of import capability, respectively.<sup>108</sup> The export capability of these lines is 5 MW, 153 MW, and 105 MW.

*The Power Corporation Act* grants SaskPower the exclusive right to supply, transmit and distribute electricity in the province other than in the City of Saskatoon and Swift Current. SaskPower's parent is the Crown Investment's Corporation (CIC) of Saskatchewan. The CIC provides strategic direction and the CIC responds to government direction as reflected in the annual Speech from the Throne and formal policy statements. The Board of Directors is appointed by the Lieutenant Governor and is accountable to the Minister Responsible for SaskPower, with the Minister functioning as a link between the provincial cabinet and the Legislative Assembly.

The *Power Corporation Act* provides that "When required to do so by the Crown Investments Corporation of Saskatchewan, the corporation [SaskPower] shall submit to the Crown Investments Corporation of Saskatchewan for review and prior approval any rates, charges and prices at which any goods, utilities or services are sold or provided by the corporation and that the corporation proposes to establish or revise pursuant to subsection (3)." The *Power Corporation Act* also gives the Lieutenant Governor the right to issue regulations regarding any matter necessary to carry out the intent of the Act.

---

<sup>107</sup> <http://www.saskratereview.ca/images/docs/SaskPower2013/saskpower-rate-application-report.pdf>, p. i and SaskPower 2013 Annual Report. This excludes capital leases of \$1.1 billion as of the end of 2013.

<sup>108</sup> The capabilities of these interconnections vary with system load and generation capabilities.

SaskPower opened its wholesale market (i.e., service to the municipal utilities in Saskatoon and Swift Current) to competition in 2001 through an open access transmission tariff. With no formal regulator in Saskatchewan, SaskPower has established an Open Access Transmission Tariff (OATT) Customer Dialogue Group to address regulatory issues, rate changes and policy issues. Disputes that cannot be resolved by the OATT Customer Dialogue Group would be heard by the Minister for SaskPower. The courts would be the venue for any commercial disputes.

SaskPower is the Reliability Coordinator (RC) for the Balancing Authority and Transmission Operator functions in the SaskPower system, which is a subregion within the Midwest Reliability Organization (MRO) Region of NERC. The SaskPower Reliability Coordinator Area consists of the transmission and generation facilities within the boundaries of Saskatchewan. The SaskPower RC functions associated with power supply reliability include review and approval of planned transmission facility line outages, planned generation outages, monitoring of real-time loading conditions, loading relief procedures, generation re-dispatch, current day and next day reliability evaluations of the integrated transmission and generation systems and coordination/communication with other Reliability Coordinators. SaskPower RC procedures and policies are consistent with those of NERC. With no formal regulator, SaskPower has established an internal Saskatchewan Reliability Authority, which is composed of a panel of non-operating SaskPower executives to rule on reliability standards and order compliance with the standards. SaskPower reports that this approach has been very effective and works well for the province.

Regulatory oversight over SaskPower is limited relative to other jurisdictions. The Rate Review Panel's scope is largely limited to rate requests. For example, the Rate Review Panel has no responsibilities regarding major capital investments or overseeing SaskPower's integrated resource planning.

The Minister responsible for the CIC provides the Panel with instructions regarding the scope of each rate review. The Panel then:

- Posts the rate application and specific terms of reference on its web site;
- Hires consultants to assess the application and provide the Panel with technical advice;
- Invites comments or submissions from customers and the public by email, letters and telephone messages; and
- Holds public meetings to provide information, encourage discussion and answer any questions.

The Panel analyzes all of the materials received from SaskPower, customers, the public and its consultants.<sup>109</sup> It prepares and submits a written report containing its observations and recommendations to the Minister responsible for the Crown Investments Corporation and the Minister and President responsible for the particular Crown. The Panel's report and a media release summarizing the main elements of the report are posted on the Panel's web site. The Minister for

---

<sup>109</sup> The Rate Review Panel relies on consultants to perform much of the review of SaskPower's rates.



the Crown proposing a rate change then presents the Panel’s final report, together with the Crown Corporation’s analysis of the report and recommendations, to Cabinet.

Similar to Newfoundland and Labrador, many of the areas served by SaskPower have a very low customer density, with 308 m of transmission and distribution lines per customer, which is considerably more than most other Canadian utilities.<sup>110</sup>

A large portion of SaskPower’s generation and distribution assets are at or near the end of their useful life. SaskPower is refurbishing and replacing these assets. This requires significant amounts of capital and presents various risks associated with the underlying reliability of service to its customers.

In October 2013, SaskPower requested a 5.5% increase effective January 1, 2014, 5% effective January 2015, and 5% effective January 2016. Two items are driving the vast majority of the increase in the revenue requirements; capital projects represent about 72%, while the forecasted increases in fuel and purchased power costs, represents about 16%. In April 2014, the Rate Review Panel recommended that the government approve SaskPower’s rate increase request for 2014 of 5.5% and 5% increase for 2015, subject to additional filings by SaskPower. Given the uncertainty regarding the need for the request in 2016, the Rate Review Panel recommended that that request not be allowed based on the evidence presented. In addition, the Rate Review Panel requested that SaskPower “develop a public dialogue to further educate customers and key stakeholders on the need for Capital Projects, and to provide more transparency on its current plans, to ensure they are implemented in a timely and cost-effective manner.”<sup>111</sup>

One innovation SaskPower is pursuing is what it calls the Turnkey Solution Initiative, with SaskTel and SaskEnergy, which allows major developers to take responsibility for engineering, materials procurement, and construction of distribution infrastructure for major developments. This allows SaskPower to reduce overheads and to focus on system improvement, maintenance, and operations.

#### **4.4 Manitoba**

Manitoba Hydro also represents a valuable point of reference as a predominately hydroelectric, vertically integrated electric utility. In addition to being the sole commercial provider of electric power in the province serving over 555,000 customers, Manitoba Hydro also provides natural gas service to 260,000 customers. Effectively, Manitoba Hydro is the sole energy distribution company in Manitoba. It acquired Centra Gas Manitoba, which provided natural gas distribution service in urban areas in Manitoba, in 1999 and Winnipeg Hydro, which was municipally owned and provided electricity distribution service, in 2002.

---

<sup>110</sup> <http://www.saskratereview.ca/images/docs/SaskPower2013/2014-rate-app-public-presentation.pdf>, p. 7

This measure is influenced by the fact that two of SaskPower’s customers are municipal electric systems which serve many customers.

<sup>111</sup> Rate Review Panel, News Release, April 28, 2014, <http://www.saskratereview.ca/images/docs/SaskPower2013/srrp-skpower-media-release-apr28-posting.pdf>.

Similar to many Canadian electric utilities, Manitoba Hydro is faced with the challenges of refurbishing aging infrastructure and undertaking major new capital investments while seeking to minimize rate increases and maintain system reliability. It recently filed an application with the Manitoba Public Utilities Board (PUB) for a 3.95% across the board rate increases April 1, 2015 and April 1, 2016. The PUB will convene a formal review of this rate request and make a recommendation to Government.

Manitoba Hydro's customers benefit from among the lowest rates in North America which are attributable to past investments in hydroelectric generating stations and revenue that's been earned from selling surplus energy into export markets. With relatively limited storage capability,<sup>112</sup> the approximately 9 million MWh annual difference between its dependable and average hydroelectric capability is typically available for export.<sup>113</sup> This limited storage capability and the location of hydroelectric facilities on relatively few river systems with a number of facilities downstream, causes Manitoba Hydro to devote considerable effort to optimizing its hydroelectric production.

Manitoba Hydro's export strategy is predicated on long-term contracts that support the development of new hydroelectric projects and reduce the effective cost of these projects to customers.<sup>114</sup> Under this structure Manitoba Hydro customers bear much of the risk of these new major hydroelectric projects and Manitoba Hydro mitigates this risk through long-term contracts typically with electric utilities in the Upper Midwest. In essence, Manitoba Hydro commits to the construction of hydroelectric projects prior to the Province's internal needs and sells a portion of the project's total output to electric utilities in the Upper Midwest. Several of these contracts also provide seasonal diversity that allows Manitoba Hydro to call upon capacity and energy from these utilities during peak winter periods, if needed.

Reflecting these export contracts which are primarily with US electric utilities in the MISO market, Manitoba Hydro is well interconnected with US electric utilities, less so with Ontario and Saskatchewan. Interestingly, even though it has an OATT and a small market share that would enable it to secure market-based rate authority, Manitoba Hydro doesn't have such authority from the Federal Energy Regulatory Commission (FERC) so it sells power at the Canada-US border. Manitoba Hydro indicated that it has elected to sell at the border to avoid US taxes on income earned from its export sales.<sup>115</sup>

---

<sup>112</sup> This is in direct contrast to Hydro-Québec who has considerable storage capability and thus able to use its reservoirs to manage variations in water run-off and to capitalize in seasonal daily differences in price levels rather than having to sell surplus energy in export markets as an alternative to spilling water.

<sup>113</sup> Interestingly, Manitoba Hydro's exports over the last several years have averaged about 10 million MWh, roughly equivalent to this difference.

<sup>114</sup> For example in its 2013-14 Annual Report, Manitoba Hydro highlighted recently signed power sales agreements with Wisconsin Public Service resulting in two new power sales; one for 108 megawatts from 2016 to 2021 and another for 308 megawatts for up to 10 years starting in 2027. What is particularly striking is a ten year contract starting about 14 years in the future. This contract was predicated on the development of Conawapa Hydroelectric Project and a means for Manitoba Hydro to manage the surplus that it would otherwise have if the 1,485 MW project were developed without such sales agreements.

<sup>115</sup> Email from David Cormie, Division Manager Power Sales and Operations, Manitoba Hydro

#### 4.4.1 Provincial Legislation

The purpose of *The Manitoba Hydro Act* is “to provide for the continuance of a supply of power adequate for the needs of the province, and to engage in and to promote economy and efficiency in the development, generation, transmission, distribution, supply and end-use of power and, in addition, are:

(a) To provide and market products, services and expertise related to the development, generation, transmission, distribution, supply and end-use of power, within and outside the province; and

(b) To market and supply power to persons outside the province on terms and conditions acceptable to the board.”<sup>116</sup>

*The Act* specifically recognizes that Manitoba Hydro will market and supply power to persons outside the province, but makes clear that the focus is on the supply of power adequate for the needs of the province and to engage in and promote economy and efficiency in the development, generation, transmission, distribution, supply and end-use of power. Given the importance of these exports, Manitoba Hydro devotes a considerable amount of effort to ensuring that it realizes the full potential benefits of its participation in these export markets. For example, Manitoba Hydro actively supported a MISO study that evaluated the benefits offered by increased hydroelectric and associated transmission interconnection development in Manitoba on the costs of integrating additional wind resources in the US Midwest.<sup>117</sup>

The CEO of Manitoba Hydro is appointed by the Board, but subject to the approval of the government.

*The Manitoba Hydro Act* provides that the Government shall not introduce legislation to privatize Manitoba Hydro unless there has been a referendum in the province and the majority of voters supported the referendum.

*The Manitoba Hydro Act* also allows for rules and procedures to separate functions (e.g., generation and transmission) which are necessary to pursue opportunities to purchase and sell power within and outside Manitoba. This allows Manitoba Hydro to comply with the functional separation requirements between transmission and merchant operations reflected in FERC Order 889. In addition, for the purposes of pursuing opportunities to purchase and sell power within and outside Manitoba, subject to the approval of the government, Manitoba Hydro may adopt standards, rules, terms and conditions which are related to the planning, design or operation of generation or transmission facilities within an integrated regional power grid. This facilitates Manitoba Hydro’s

---

<sup>116</sup> Section 2.

<sup>117</sup> Power Advisory LLC, Case Study Analysis of Hydro-Variable Renewable Electricity Integration Strategies, prepared for NRCAN, July 2013.

participation in MISO which administers an electricity market which encompasses significant portions of the US Midwest.

Manitoba Hydro became contractually obligated to adhere to North American Electrical Reliability Council (NERC) reliability standards in 1996 as a result of its membership in the Mid-continent Area Power Pool (MAPP). When NERC reorganized in 2005, Manitoba Hydro joined MAPP's successor organization the Midwest Reliability Organization (MRO), a region of NERC. Manitoba Hydro continues its membership in MAPP, which retains its function as a generation reserves sharing pool. Manitoba Hydro has a coordination agreement with Midwest ISO (MISO) under which MISO provides tariff administration services, transmission planning activities and contingency reserve sharing. In particular, Manitoba Hydro is responsible for serving its own load and MISO is responsible for certain tariff administration services, transmission settlements, administration of the contingency reserve sharing agreement and reliability coordination. MISO also serves as the reliability coordinator for Manitoba.

Manitoba Hydro currently has such a contingency-reserve sharing agreement with MISO, which requires Manitoba Hydro to supply 150 MW of contingency reserve, with 60 MW of that quantity spinning (or immediately available) and the other 90 MW available within 15 minutes. Firm transmission is reserved on the Manitoba to U.S. interconnection to supply these reserves.

Amendments to *The Manitoba Hydro Act* create a comprehensive scheme for the adoption and enforcement of reliability standards applicable to all owners, operators and users of the bulk power system in Manitoba, which consists primarily of Manitoba Hydro and various IPPs with power sales agreements with Manitoba Hydro.<sup>118</sup> Government was given authority to suspend, disallow, or approve the adoption of MRO and NERC standards. Typically, Manitoba Hydro advises government with respect to such actions. Under *The Public Utilities Board Act* the PUB may impose financial penalties for non-compliance including establishing whether there was non-compliance.

The government can make regulations that require those persons who violate reliability standards to prepare and implement plans to correct those violations and prevent their recurrence and the PUB is authorized to resolve specified disputes between NERC and MRO, who are responsible for monitoring the standards, and persons required to comply with their reliability standards. *The Manitoba Hydro Act* also provides that a reliability standard adopted under the legislation may not: (i) have the effect of requiring the construction or enhancement of facilities in Manitoba; (ii) apply to facilities in Manitoba that do not materially affect the regional electricity grid; or (iii) relate to the adequacy of generation resources in Manitoba.

The role of the PUB in rate setting is to hear evidence and based on that evidence report to the minister its recommendations as to the prices that should be charged by Manitoba Hydro. The minister shall then refer the report to the Lieutenant Governor who shall direct Manitoba Hydro as

---

<sup>118</sup> Obligations are placed on these generators under Manitoba Hydro's Open Access Interconnection Tariff.

to the prices to be charged. The Act also gives the government broad powers to direct Manitoba Hydro.

*The Public Utilities Board Act* outlines the roles and responsibilities of the PUB vis-à-vis Manitoba Hydro. Interestingly, *The Public Utilities Board Act* specifies that Manitoba Hydro is largely exempt from PUB oversight, other than reviewing its rates and the PUB's oversight over electricity rates is limited to recommending rates to government who ultimately directs Manitoba Hydro regarding what rates to charge. Specifically, parties selling power to Manitoba Hydro can ask the PUB to review the price for such sales and parties may also request the PUB to review the reasonableness of assessments for interconnection costs. As such the PUB doesn't review Manitoba Hydro's major investment decisions as part of its normal course of business nor is there any oversight over Manitoba Hydro's capital expenditures. Furthermore, there's no requirement for Manitoba Hydro to develop an integrated resource plan. Finally, unlike most other Canadian provinces, the PUB doesn't oversee the administration of Manitoba Hydro's transmission tariff such that if a third party has a complaint with the administration of the tariff it is heard by Manitoba Hydro.<sup>119</sup>

The PUB's relatively limited oversight over Manitoba Hydro is reflected in regulatory practice in Manitoba. Manitoba Hydro is able to limit access to a considerable amount of information claiming confidentiality and by withholding information by refusing to accept confidential undertakings. Furthermore, it doesn't provide live spreadsheets and the PUB has not directed it to provide such.<sup>120</sup> The PUB oversight over the Manitoba Hydro is relatively constrained.

However, in November 2012, the Manitoba government announced that a PUB panel would conduct the Needs for and Alternatives To (NFAT) review of Manitoba Hydro's preferred development plan which includes the Keeyask and Conawapa generating stations, their associated domestic transmission facilities and a new Canada-U.S. transmission interconnection. Given the estimated \$13 billion budget, the PUB was asked to conduct a thorough public review of Hydro's plan and to make an overall assessment as to whether or not the plan is needed at this time and is in the best long-term interest of the province when compared to other options and alternatives.

As part of the review conducted by the PUB, in August 2013 Manitoba Hydro filed its preferred development plan which included the 695-megawatt Keeyask Hydroelectric Generating Station, a new 500 kV transmission interconnection with Minnesota, and additional export sales. The plan also includes the 1,485-megawatt Conawapa Hydroelectric Generating Station (Conawapa) subsequent to Keeyask. Recognizing that there wasn't a need to commit to Conawapa until about 2018, the decision for it was framed in terms of "protecting the option to build Conawapa." In its decision, the PUB recommended that the government support Manitoba Hydro's proposal to build Keeyask and the additional 500 kV interconnection. However, the PUB found: "the risks

---

<sup>119</sup> This is not viewed to be a best practice.

<sup>120</sup> In the NFAT Review discussed below, the PUB had to direct Manitoba Hydro to provide a considerable amount of information.

associated with the Conawapa Project are unacceptable. It is too speculative in light of rapidly changing conditions in North American electricity markets.”<sup>121</sup> While this decision can be viewed as a setback for its efforts to build Conawapa, Manitoba Hydro didn’t require an approval at that time. A commitment in 2018 will be by definition lower risk than a commitment in 2014 given that there will be greater certainty regarding future market conditions, e.g., the value of reduced carbon emissions. Therefore, it isn’t clear that Manitoba Hydro won’t ultimately develop Conawapa.

## **4.5 Ontario**

Similar to Newfoundland and Labrador, the Ontario government is responsible for setting the legislative and policy framework over the production, transmission, and sale of electricity within the province. However, in most other ways the structure of Ontario’s electricity sector is significantly different than Newfoundland and Labrador’s. Therefore, a number of elements of Ontario’s electricity sector will not be explored deeply. Historically, electricity generation and transmission to residential, commercial and industrial users was largely the responsibility of the Crown corporation, Ontario Hydro, along with a number of municipal utilities. Electricity prices were regulated by the provincial government at that time. In 1998, Ontario Hydro was reorganized into five entities, namely, Ontario Hydro Services Company (renamed Hydro One), Ontario Power Generation, the Independent Electricity Market Operator, the Electrical Safety Authority, and the Ontario Electricity Finance Corporation. Currently the Ontario Ministry of Energy (Ministry) is responsible for providing the regulatory framework and implementing the government’s electricity policies, and does this in part through oversight of Ontario Hydro’s successor companies.

Many changes have been implemented since the initial restructuring of the Ontario electricity market in 1998/1999. Ontario competitive wholesale and retail electricity markets opened on May 1, 2002. The original competitive market structure ultimately failed, as it did not provide sufficient investor confidence to induce generation investment. Given wholesale prices and concerns regarding Ontario Power Generation’s role in the market, private-sector electricity generators were unwilling to invest without some form of government-backed contract. As a result, Ontario migrated towards its current hybrid market structure, consisting of a competitive wholesale energy market which is used to coordinate generator dispatch and operations and centrally procured electricity supply contracts which drive investment. The “market” consists of a real-time physical market for energy and operating reserves, and a Financial Transmission Rights market. In reality this wholesale energy market is really a balancing market, not the basis upon which new generation is built.

### **4.5.1 Legislation**

The following key electricity policy changes have shaped the Ontario electricity market:

---

<sup>121</sup> PUB, Needs For And Alternatives To (NFAT) Review of Manitoba Hydro’s Preferred Development Plan – Final Report, p. 35

- The *Electricity Act*, 1998, outlines the framework for Ontario's competitive electricity marketplace;
- Bill 35: *Energy Competition Act*, 1998 re-organized Ontario Hydro into five entities and established competitive wholesale and retail markets;
- Bill 210: *Electricity Pricing, Conservation and Supply Act*, 2002 capped retail rates and froze transmission and distribution rates;
- Bill 100: *Electricity Restructuring Act*, 2004 created the Ontario Power Authority and established demand-side and generation procurement programs along with power system plans to be approved by the Ontario Energy Board. It also modified the *Ontario Energy Board Act*, 1998 where the Ontario Energy Board became responsible for creating a mechanism to establish retail rates for eligible consumers;
- Bill 150: *Green Energy and Green Economy Act*, 2009 expanded Government authority to more directly ensure the development of demand-side resources and renewable energy supply with an emphasis on creating 'green' jobs;
- Bill 194<sup>122</sup>: *An Act to implement Budget measures and to enact and amend various Acts*, 2014, which re-introduced legislation to amalgamate the Ontario Power Authority and the Independent Electricity System Operator.

#### 4.5.2 Major Electricity Sector Agencies

A summary of the major electricity sector agencies in Ontario follows.

##### 4.5.2.1 Ontario Energy Board

The Ontario Energy Board (OEB) regulates Ontario's electricity and natural-gas sectors. It is an independent regulatory agency mandated to protect the interests of consumers with respect to the price, adequacy, reliability, and quality of electricity service. It is also responsible for promoting economic efficiency and cost effectiveness in the generation, transmission, and distribution of electricity. Most of Ontario's utilities have their rates regulated by the OEB. The rate-regulated electric utilities include the province's largest local distribution company (LDC), Hydro One Networks (discussed below), as well as 75 other distribution companies.

The OEB's objectives are:

1. To protect the interests of consumers with respect to prices and the adequacy, reliability and quality of electricity service.
2. To promote economic efficiency and cost effectiveness in the generation, transmission, distribution, sale and demand management of electricity and to facilitate the maintenance of a financially viable electricity industry.
3. To promote electricity conservation and demand management in a manner consistent with the policies of the Government of Ontario, including having regard to the consumer's economic circumstances.
4. To facilitate the implementation of a smart grid in Ontario.

---

<sup>122</sup> [http://www.ontla.on.ca/bills/bills-files/40\\_Parliament/Session2/b194.pdf](http://www.ontla.on.ca/bills/bills-files/40_Parliament/Session2/b194.pdf).

5. To promote the use and generation of electricity from renewable energy sources in a manner consistent with the policies of the Government of Ontario, including the timely expansion or reinforcement of transmission systems and distribution systems to accommodate the connection of renewable energy generation facilities.

The fourth objective is interesting and reflects what we believe is the tendency of policy makers to give too much attention to the “flavor of the year”, rather than to allow the regulator to determine if the development of Ontario’s smart grid is in the public interest. Unlike renewable energy, which has favourable attributes that are specific to it, what is valuable about a smart grid are the specific attributes not the presence of a smart grid itself. From another perspective, one can have smart grid investments which don’t provide these desirable attributes.

#### **4.5.2.2 Ontario Power Generation**

Ontario Power Generation (OPG) is the dominant electricity supplier in Ontario. OPG’s principal business is the generation and sale of electricity to customers in Ontario and its interconnected markets. OPG was established under the *Business Corporations Act*, 1999 and is wholly owned by the Province of Ontario. OPG is licensed by the OEB.

OPG’s mandate is to cost-effectively produce electricity from its diversified portfolio of generating assets.<sup>123</sup> In 2005, OPG and its sole shareholder reached agreement on this mandate which is detailed in a Memorandum of Agreement (MOA). The MOA serves as the basis of agreement between OPG and the Government of Ontario on OPG’s mandate, governance, performance and communications.<sup>124</sup>

OPG owns a large portfolio of generating assets, and provides nearly half of Ontario’s power output. As of September 30, 2014, OPG had 16,958 MW of in-service generating capacity, consisting of 2 nuclear generating stations, 3 thermal generating stations, 65 hydroelectric generating stations on 24 river systems, and 2 wind turbines. Per government mandate OPG retired about 6,000 MW of coal-fired generation capacity over the last ten years.

#### **4.5.2.3 Independent Electricity System Operator**

The Independent Electricity System Operator (IESO) is responsible for the day-to-day operation of Ontario’s electrical system. The IESO is responsible for maintaining the security and reliability of electricity supply in Ontario and for directing the operations of the IESO-controlled grid. The OEB approves the license, business plan and fees of the IESO. As discussed below, on January 1, 2015, the IESO was amalgamated with the Ontario Power Authority (OPA).

---

<sup>123</sup> OPG’s mandate is to cost-effectively generate electricity while operating in a safe, open and environmentally responsible manner.

<sup>124</sup> <http://www.opg.com/about/management/open-and-accountable/Documents/memorandum.pdf>.



#### **4.5.2.4 Ontario Power Authority**

Prior to merging with the IESO on January 1, 2015, the OPA reported to the Ontario legislature through Ontario's Ministry of Energy. It was licensed by the OEB. The OPA's key objectives were to ensure the adequacy and reliability of Ontario's electricity supply through long-term planning and procurement. The OPA was the counterparty to the vast majority of contracts awarded in Ontario.

#### **4.5.2.5 Hydro One**

Hydro One Networks Inc. (Hydro One Networks) is the electricity transmission and distribution successor to the original Hydro-Electric Power Commission of Ontario, which became Ontario Hydro in 1974. Following the enactment of the *Electricity Act*, 1998 and the restructuring of the former Ontario Hydro, Hydro One Inc. was incorporated under Ontario's *Business Corporations Act* on December 1, 1998. Its principal subsidiary, Hydro One Networks is the largest electricity transmitter and distributor in Ontario.

In 2008, a Memorandum of Agreement (MOA)<sup>125</sup> was established between Hydro One Inc. and its sole shareholder. The MOA serves as the basis of agreement between Hydro One and the Government of Ontario on Hydro One's mandate, governance, responsibilities, performance expectations and executive compensation.

On April 16, 2015, the Ontario government announced that it would proceed with an Initial Public Offering (IPO) of the shares of Hydro One before the end of the current fiscal year, with a goal of having government own no more than 40% of the company, but with no single shareholder owning more than 10%. This IPO is discussed further below in section 4.5.5.2.

As Ontario's largest regulated electric utility comparable to NLH, the organizational structure of Hydro One Networks Inc. is presented in the figure below. Hydro One Networks places considerable attention to its regulatory function, and has a Vice President, Regulatory and Chief Regulatory Officer.

#### **4.5.2.6 Ontario Electricity Financial Corporation (OEFC)**

OEFC was also established with the passage of the *Electricity Act*, 1998. Its primary responsibility is the management and retirement of Ontario Hydro's outstanding debt and other obligations.

#### **4.5.2.7 Ministry of Energy**

The Ontario Ministry of Energy (Ministry) is responsible for providing the regulatory framework and implementing the government's electricity policies. The Ministry has legislative responsibility for several agencies, including Hydro One, OPG, the IESO and the OEB.

---

<sup>125</sup> Available here:

[http://www.hydroone.com/OurCompany/Documents/Governance/MOA\\_Shareholder\\_Agreement\\_March\\_27\\_2008.pdf](http://www.hydroone.com/OurCompany/Documents/Governance/MOA_Shareholder_Agreement_March_27_2008.pdf).

### 4.5.3 Ministerial Directives

The former OPA was bound by directives issued under the *Electricity Act*, 1998 by the Minister of Energy which articulated government policy. Under the authority to issue directives, the Minister directed certain aspects of the OPA's planning and procurement of electricity supply, including price and whether to use competitive or non-competitive procurement processes. The Minister issued 93 directives to the OPA over the ten year period from 2005 to 2014, demonstrating the significant role that government had in directing the actions of the OPA.<sup>126</sup>

### 4.5.4 NERC Reliability Obligations

The IESO is the sole Ontario entity accountable to NERC or Northeast Power Coordinating Council (NPCC) for compliance with NERC reliability standards. The Ontario Reliability Compliance Program (ORCP) is used by the IESO to monitor, assess and enforce compliance with reliability standards and criteria in Ontario. Under the ORCP, IESO market participants that are subject to compliance with NERC standards and NPCC criteria are required to:

- Self-certify their compliance status with the reliability standards actively monitored by the IESO;
- Self-report potential breaches of reliability standards, indicating actions taken or that will be taken to resolve the breach; and
- Respond to any other reliability data submittal requests by the IESO under the ORCP.

---

<sup>126</sup> See complete list of Directives here: <http://www.powerauthority.on.ca/about-us/directives-opa-minister-energy-and-infrastructure>.

**Figure 37: Hydro One Networks Inc. Organizational Chart<sup>127</sup>**

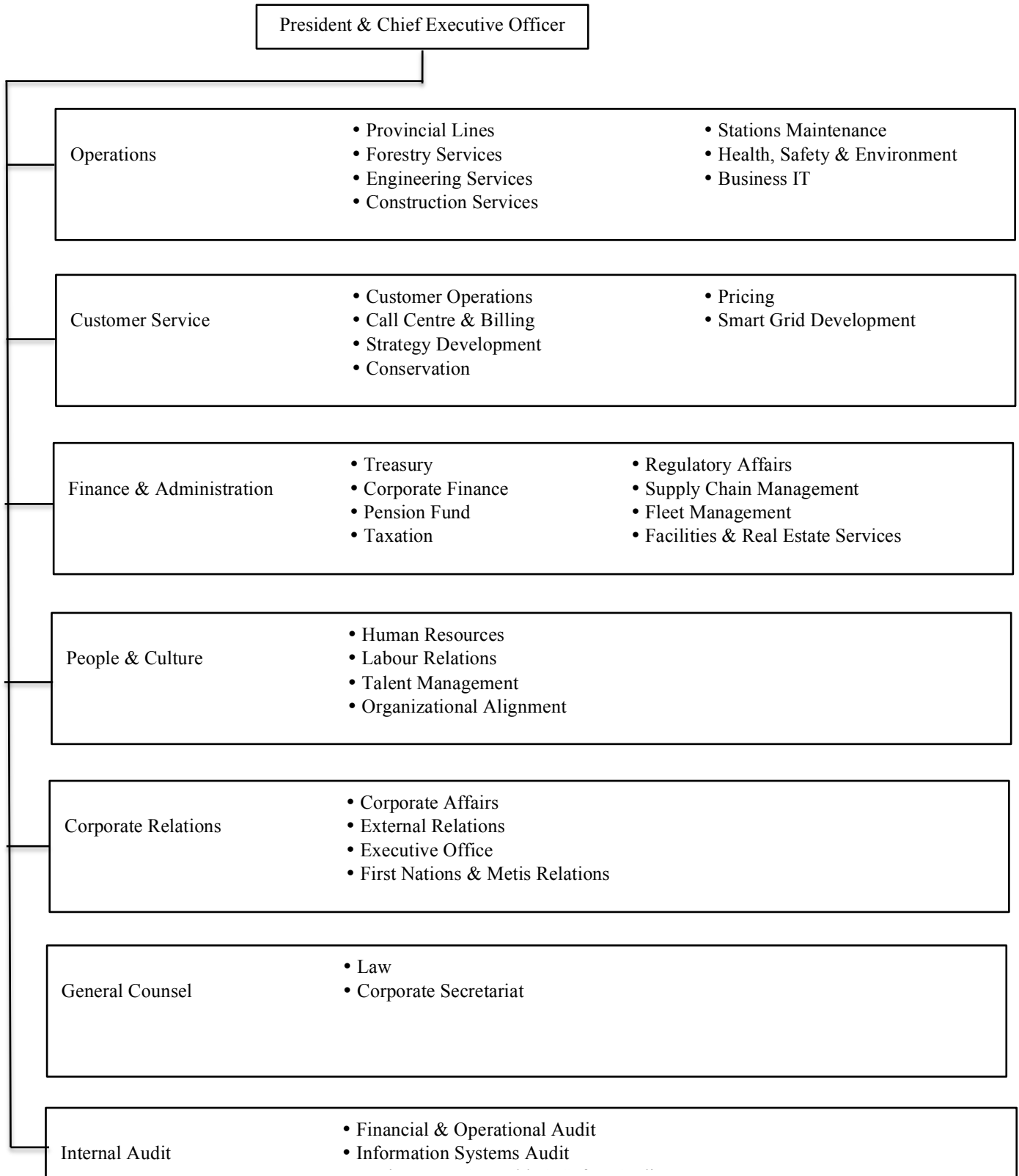

Source: Hydro One Corporate Organization Charts

<sup>127</sup> Shown are divisions and service groups that report to the President and CEO.

The IESO has the authority under s. 32(1) (c) of the *Electricity Act*, 1998 to establish standards and criteria relating to the reliability of electricity service or the IESO-controlled grid, if necessary.

The OEB is the Applicable Governmental Authority<sup>128</sup> for Ontario as defined by NERC. The OEB also has the legislative authority to stay or revoke the operation of a reliability standard in Ontario and refer it back to NERC or the NPCC for further consideration.

#### **4.5.5 Ongoing Efforts to Rationalize Ontario’s Electricity Sector**

The province’s electricity sector has been criticized for rising prices, poor price signals, a lack of cost transparency, and contradictory policies. Government is undertaking initiatives to address these issues. The following are examples of recent initiatives to reform the sector. The Ontario government initiated work on these issues in 2005 with the formation of the Agency Review Panel, which first recommended the amalgamation of the IESO and OPA.

##### **4.5.5.1 Ontario Distribution Sector Review Panel**

In April 2012, the Ontario Minister of Energy established the Ontario Distribution Sector Review Panel to provide advice to the government on how to improve efficiencies in the sector with the aim of reducing the cost of electricity distribution for electricity consumers.

In December 2012, the Panel released the report *Renewing Ontario’s Electricity Distribution Sector: Putting the Consumer First*,<sup>129</sup> which provided a detailed review of the sector and a plan detailing a new model for electricity distribution in Ontario. The report highlighted the uniqueness of the structure of Ontario’s distribution system and provided specific recommendations which included consolidating 73 LDCs into 8-12 larger regional distributors, the goal of which would be to improve efficiency and enhance customer focus.

##### **4.5.5.2 Premier’s Advisory Council Review**

In April 2014, the Premier of Ontario appointed a council to review and identify opportunities to modernize government business enterprises. The council was assembled to report on several Government assets including Hydro One and OPG, and to make recommendations to maximize the value and performance of the enterprises.

In completing their review, the Advisory Council took into account the government’s preference to retain core assets in public ownership. The review was designed to be conducted in two phases: Phase 1, which incorporated detailed reviews of the subject entities, stakeholder consultation and

---

<sup>128</sup> “Applicable Governmental Authority” means the governmental authority with subject matter jurisdiction over reliability in Canada and Mexico. Within the United States, the FERC is considered the Applicable Governmental Authority. Governmental Authorities approve regional or provincial (in the case of Canada) reliability standards and prescribe reliability enforcement procedures.

<sup>129</sup> Report is available here: <http://www.energy.gov.on.ca/en/ldc-panel/#e>.

the development of the Council’s initial thinking on proposals for the future direction of each company, and Phase 2, which incorporated further discussion and consultation on the proposals. The results of Phase 1 of the review were presented in the Council’s initial report, entitled *Retain & Gain: Making Ontario’s Assets Work Better for Taxpayers and Consumers*, which was released on November 13, 2014. The results of the Phase 2 review were presented in the second report, *Striking the Right Balance: Improving Performance and Unlocking Value in the Electricity Sector in Ontario*.<sup>130</sup>

The Phase 1 report noted that opportunities exist for operational improvements in both the transmission and distribution businesses of Hydro One. However, the challenges in Ontario’s local electricity distribution system were highlighted in the report: namely “...there are too many entities, some of them inefficient, that lack the capability and capital to modernize and adapt to the changing environment.”<sup>131</sup> The Council agreed with the Ontario Distribution Sector Review Panel’s core conclusions that Ontario is in need of a more consolidated and efficient electrical distribution system. Specific recommendations of the Council include:

- The Province should retain the Hydro One transmission business;
- Hydro One should separate its distribution assets from the rest of its business; and
- Private sector capital, rather than public funds, should be used to support the required consolidation of the Ontario LDCs.

As discussed, the Phase 2 Report recommended and the Ontario government subsequently accepted these recommendations and announced its intention to proceed with an Initial Public Offering of shares in Hydro One Inc. before the end of the current fiscal year. In addition, the Council recommended that Hydro One Brampton, which serves the city of Brampton and Hydro One acquired about 15 years ago, be used as a catalyst for local distribution company (LDC) consolidation. Such consolidation is expected to result in greater economies of scale in the distribution of electricity and lower costs for customers. This would be accomplished by selling Hydro One Brampton to three large distribution utilities in the Greater Toronto Area, as part of a merger of those LDCs.

The Council’s specific recommendations relating to OPG include:

- OPG should work to realize operational savings identified over time; and
- OPG should consider creating an internal structure over time as if there were two separate entities focused on their very different businesses: nuclear and non-nuclear generation.

#### **4.5.5.3 Amalgamation of OPA and IESO**

On January 1, 2015, the OPA and the IESO were merged. The government’s intention in amalgamating these agencies was to streamline electricity sector planning by reducing overlap, improving agency efficiency, reducing costs and helping to mitigate future cost impacts to

---

<sup>130</sup> <http://docs.files.ontario.ca/documents/4428/improving-performance-and-unlocking-value-in-the-pdf>

<sup>131</sup> p. 7.

ratepayers. The new agency is now operational under the name Independent Electricity System Operator (IESO). As part of the merger:

- The OPA's statutory objectives and power for planning and procurement were transferred to IESO;
- IESO became subject to government directives; and
- Existing procurement contracts were grandfathered.

It is expected that a reduction to the IESO/OPA's revenue requirement of approximately \$5 million or about 3% will be achieved in the first year of amalgamation.<sup>132</sup>

#### 4.6 Quebec

Hydro-Québec is a government-owned public utility that generates, transmits and distributes electricity in the vast majority of the province of Québec. Hydro-Québec is the largest electricity generator in Canada, using primarily hydroelectric generation. It has a total installed capacity of approximately 36,000 MW<sup>133</sup>, and serves over 4.1 million customers.

It was established in 1944 by its sole shareholder, the Québec government, and was reorganized in 2001. In 1997, Hydro-Québec adopted an OATT based on the model proposed by U.S. FERC Order No. 888 to allow it to sell electricity in the U.S. on a market basis.

In 2001 the Québec electricity market was restructured by the vertical separation of Hydro-Québec. The *Act to amend the Act respecting the Régie de l'énergie* established a Heritage Pool giving Québec consumers access to a maximum volume of 165 million MWh (plus associated losses) of electricity per year from Hydro-Québec Production at a rate of \$27.90/MWh, which now escalates with the Consumer Price Index, thereby ensuring that these customers continued to have access to the low cost power available from Hydro-Québec Production. The Heritage Pool effectively guaranteed that Québec consumers would continue to have access to the low cost energy that Hydro-Québec Production produced or contracted for while allowing it to realize an attractive return as the effective cost of these facilities that produce this energy declines over time. For volumes beyond this 165 million MWh covered by the Heritage Pool, Hydro-Québec Production competes with other suppliers to supply Hydro-Québec Distribution. This also ensures that Québec consumers are shielded from the risks of investments in major new hydro projects.

To evaluate the need for additional power supplies and to assist prospective competitors participate in such processes, every three years Hydro-Québec Distribution prepares a supply plan covering the next 10 years. This plan presents forecasts of customers' electricity requirements, taking into account energy efficiency measures that have been implemented, along with other resources that are available to ensure a reliable supply of electricity for Québec. The supply plan must be approved by the Régie de l'énergie and is subject to follow-up on an annual basis.

---

<sup>132</sup> See page 4 of [http://www.ieso.ca/Documents/media/BCampbell\\_APPrO\\_Nov\\_18\\_2014.pdf](http://www.ieso.ca/Documents/media/BCampbell_APPrO_Nov_18_2014.pdf).

<sup>133</sup> The province's installed capacity was 36,068 MW in 2013. See <http://www.hydroquebec.com/about-hydro-quebec/who-are-we/hydro-quebec-glance.html>.

The four primary Hydro-Québec divisions that resulted from this restructuring were: (1) Hydro-Québec Production which is obligated to provide the heritage pool energy to Hydro-Québec Distribution and typically sells surplus power in export markets and conducts buy/sell transactions (i.e., uses its storage capability to take advantage of price differences over time where profitable); (2) Hydro-Québec Distribution which procures and supplies electricity above the 165 million MWh (plus losses) provided by Hydro-Québec Production competitively through tenders; (3) Hydro-Québec TransÉnergie (in place since 1997) which administers Québec's open access transmission service and plans and maintains the transmission network; and (4) Hydro-Québec Équipement.

Hydro-Québec owns 25 large reservoirs. These reservoirs are extremely useful energy storage tools which enable it to capture revenues from differences between peak and off-peak energy prices. Hydro-Québec also uses the storage capabilities of its reservoirs to integrate substantial amounts of wind power. In 2003, Hydro-Québec Distribution launched an initial call for tenders to purchase 1,000 MW of wind power. These contracts were awarded later in the year. In 2005 Hydro-Québec Distribution issued a second call for tenders to purchase 2,000 MW of wind power, which were awarded in 2008. A third call for tenders was issued in 2014 for 450 MW.

In order to meet demand beyond 165 million MWh provided by the Heritage Block, Hydro-Québec Distribution must enter into supply contracts by conducting calls for tenders among interested power suppliers. Hydro-Québec is actively involved in exporting electricity. In 2013, exports provided 32% of Hydro-Québec Production's total net income of \$2.9 billion, which yielded a dividend of \$2.2 billion.<sup>134</sup> The province has interconnections with Ontario, New Brunswick, Newfoundland & Labrador, New York, and New England, which provide over 8,000 MW<sup>135</sup> of total export capability.<sup>136</sup>

Hydro-Québec has been selling electricity to the US Northeast since the 1980s. This U.S. region accounts for approximately half the company's exports. In collaboration with Northeast Utilities, Hydro-Québec is currently pursuing the development of the Northern Pass Transmission Line which is a proposed direct-current interconnection with southern New Hampshire. The Northern Pass project is currently in the federal and state permitting phase.

Another important transmission initiative that is currently underway is the Champlain Hudson Power Express project. The Champlain Hudson Power Express is a proposed, 333-mile HVDC transmission line that will be installed underground and underwater, originating at the U.S.-Canada border and running the length of Lake Champlain and through parts of the Hudson River to New York City. The line is projected to deliver up to 1,000 megawatts of power from Hydro-Québec's transmission network near Montreal. In October 2014, the United States Department of Energy (DOE) issued a Presidential Permit for the Champlain Hudson Power Express, which was required

---

<sup>134</sup> 2013 Annual Report, p. 11.

<sup>135</sup> Hydro-Québec has 8,038 MW of interconnection export capacity. See <http://www.hydroquebec.com/transenergie/en/>.

<sup>136</sup> The simultaneous transfer capability is considerably less than this.

in order for the project to proceed with construction, operation, maintenance and connection of the electric transmission facility.

A summary of the other major electricity sector agencies in Québec follows.

#### **4.6.1 Ministère des Ressources naturelles**

The ministère de l'Énergie et des Ressources naturelles (the Ministry) is responsible for setting the policy and legislative framework for Québec's electricity system. The Ministry advises on all aspects of energy policy for Québec, including electricity, natural gas and oil.

#### **4.6.2 Régie de l'énergie**

The Régie de l'énergie (the Régie, or the Québec Energy Board) is an independent, economic regulatory agency that regulates the province's electricity and natural gas sectors in the public interest. Its mission is "to foster the conciliation of the public interest, consumer protection and the fair treatment of the electricity carrier and distributors." The Régie's creation was in response to the liberalization of the North American electricity market, including the need for a regulator to oversee the guarantee of nondiscriminatory access to markets.<sup>137</sup> The Régie has the authority to fix the rates and conditions for the transmission of electric power by Hydro-Québec TransÉnergie and the distribution of electric power by Hydro-Québec Distribution. The Régie has no regulatory oversight over Hydro-Québec Production's costs or rates.

The Régie is responsible for making all determinations and exercises all authorities concerning monitoring, investigation and enforcement of reliability standards, including the imposition of sanctions and financial penalties. The Régie also has the following responsibilities:

- Monitor the operations of Hydro-Québec Distribution to ensure that consumers are adequately supplied;
- Monitor the operations of Hydro-Québec TransÉnergie and Hydro-Québec Distribution to ensure that consumers are charged fair and reasonable rates;
- Approve Hydro-Québec Distribution's supply plans and commercial programs; and
- Approve investment projects and the acquisition of assets intended for the transmission or distribution of electric power.

The Régie's powers and responsibilities in relation to electricity are presented in Figure 38.

---

<sup>137</sup> See page 4 of the Régie's 2013/2014 Annual Report, available here: [http://www.regie-energie.qc.ca/documents/rapports\\_annuels/rapp\\_ann\\_2013-2014\\_ang.pdf](http://www.regie-energie.qc.ca/documents/rapports_annuels/rapp_ann_2013-2014_ang.pdf).



**Figure 38: Summary of the Powers of the Régie de l'énergie**



Source: The Régie's 2013/2014 Annual Report

The Régie's functions, powers, and procedures are similar to other public utility commissions in Canada since it has jurisdiction over sales to retail customers. There is no formal consumer advocate in the province of Québec.

#### 4.6.3 HQ Energy Services (U.S.)

HQ Energy Services (U.S.) Inc. is a wholly owned U.S. subsidiary of Hydro-Québec. HQ Energy Services engages in energy marketing and business development activities in the United States. HQ Energy Services takes an active role in policy development in the U.S. and its employees sit on the boards of various electricity and energy related NGOs. HQ Energy Services is believed to have had

a major role in various legislative initiatives to treat Canadian hydroelectric power on a comparable basis as Class I renewables in the US Northeast states.<sup>138</sup>

#### 4.6.4 Legislative Review

The *Hydro-Québec Act* governs Hydro-Québec's operations and defines its mission and rules of governance. Under the provisions of the *Hydro-Québec Act*, Hydro-Québec is mandated to supply power and to pursue endeavours in energy-related research and promotion, energy conversion and conservation, and any field connected with or related to power or energy. The *Règlement de régie interne d'Hydro-Québec* (Corporate governance) bylaw outlines how Hydro-Québec's Board of Directors exercises its power as well as other administrative measures that apply to the company.

The *Act respecting the Régie de l'énergie* gives Hydro-Québec the exclusive right to distribute electricity throughout the territory of Québec, excluding the territories served by a distributor operating a municipal, cooperative or private electric power system. Municipal systems have exclusive distribution rights within the territories they serve.

In 2001, the *Act respecting the Régie de l'énergie* was amended<sup>139</sup> to include legislation outlining the Régie's authority in determining the form and tenor of a resource plan and the intervals at which such a plan is to be submitted. The amendment also outlined the information that was required to be contained in each resource plan submitted by Hydro-Québec Distribution, including economic data, 10-year supply and demand data, and anticipated market needs. As a result of this legislation, Hydro-Québec Distribution prepares a resource plan every three years, which covers the timeframe of the next 10 years. Each plan must be approved by the Régie de l'énergie and is subject to follow-up on an annual basis.<sup>140</sup>

#### 4.6.5 NERC Reliability Obligations

Pursuant to its governing legislation, the *Act respecting the Régie de l'énergie*, the Régie has the authority to establish, monitor and enforce mandatory reliability standards for electricity transmission in Québec. The Régie adopts reliability standards<sup>141</sup> and sets the dates of their coming into force.

In August 2007, the Régie de l'énergie designated Hydro-Québec TransÉnergie's Direction du contrôle des mouvements d'énergie (System Control unit) as Reliability Coordinator for Québec. Under this function, it oversees the reliable operation of the provincial electricity grid. It files with the Régie reliability standards, either NERC or NPCC standards that it deems appropriate for the

---

<sup>138</sup> Class I renewables are treated as a premium resource in the US Northeast and able to realize price premiums through the trading of renewable energy certificates.

<sup>139</sup> Amendment available here: [http://www.regie-energie.qc.ca/documents/Decrets/Decret\\_925-01\\_ang.pdf](http://www.regie-energie.qc.ca/documents/Decrets/Decret_925-01_ang.pdf).

<sup>140</sup> Hydro-Québec Distribution submits a progress report on the plan to the Régie prior to November 1 of every year.

<sup>141</sup> A list of Québec's reliability standards and their status is available here: <http://www.regie-energie.qc.ca/en/audiences/NormesFiabiliteTransportElectricite/NormesFiabilite.html>.

province, as well as any variant or other standard it deems necessary. It also files a register identifying the entities that are subject to the reliability standards adopted by the Régie.

The Régie reached an agreement with NERC and NPCC in May 2009<sup>142</sup> to obtain their assistance in setting up the mandatory reliability standards in Québec and in introducing a program for overseeing compliance with the standards. A second agreement was reached in September 2014, which outlines the respective roles and responsibilities of NERC, NPCC and the Régie in implementing this compliance monitoring and enforcement program.

#### **4.6.6 FERC Obligations and Québec's Participation in Export Markets**

In 1997, FERC granted Hydro-Québec Energy Services (U.S.), a licence to sell wholesale electricity at market prices. This authorization enabled Hydro-Québec to expand its market and capitalize on business opportunities outside Québec, particularly in the northeastern U.S., through short-term buying and selling of electricity. As Quebec is directly connected to the U.S. (i.e., a tier 1 transmitter), FERC holds the province to a different standard than Newfoundland & Labrador. In particular, Hydro-Québec TransÉnergie has to meet similar standards as required of US entities that seek to sell power on a market basis and have an affiliated transmission company or own FERC-jurisdictional transmission facilities. With no direct connection to the US, Newfoundland and Labrador is held to a lower standard. See discussion in Section 5.3.2.

Hydro-Québec exports power to neighboring systems in Canada and the U.S., selling electricity under long-term contracts and actively participates in the competitive wholesale power markets in New England, New York and Ontario.

Hydro-Québec's participation in these markets is facilitated by seasonal diversity of its winter peaking system with its neighbouring US markets which are summer peaking. Hydro-Québec's production costs are also not impacted by fluctuating fuel prices. Moving forward, Hydro-Québec has expended considerable effort to allow its hydro exports to be counted towards meeting the renewable targets which many U.S. states have adopted.

Despite the success in exporting electricity to neighbouring jurisdictions, concerns surrounding the frequency of outages from Hydro-Québec have been noted. As a recent example, on December 4, 2014 ISO-New England (ISO-NE) lost 2,005 MW of energy imports from Hydro-Québec,<sup>143</sup> and had to initiate emergency operations. ISO-NE has accordingly raised concerns about relying on Hydro-Québec for such a large amount of the its capacity, especially as they are currently in the process of considering increasing the import of hydroelectric power from the province.

Consideration is therefore being given to what pressure will be put on the system if New England moves forward with increasing the amount of imports from Hydro-Québec.

---

<sup>142</sup> Agreement is available here: [http://www.nerc.com/files/NERC-Regie-NPCC\\_Agreement\\_20090508EN\\_signed.pdf](http://www.nerc.com/files/NERC-Regie-NPCC_Agreement_20090508EN_signed.pdf).

<sup>143</sup> The curtailment of electricity into New England was due to the loss of two major 735 kV transmission lines in Québec.

## 4.7 New Brunswick

Electricity service in New Brunswick is provided primarily by NB Power, a vertically integrated, Crown-owned electric utility. In addition to NB Power there are three municipally owned electric utilities that serve about 46,000 customers, in addition to the 350,000 served by NB Power.

NB Power owns 3,513 MW of generation and has another 731 MW under contract with various IPPs including 294 MW of wind capacity. Given its relatively central location New Brunswick also has interconnections with New England, Quebec, Nova Scotia and PEI that provide 2,137 MW of export capacity and 2,378 MW of import capacity. With a winter peaking system, NB Power often has considerable amounts of surplus energy available during periods when the ISO-New England market is experiencing high energy prices.

In late 2012, the Point Lepreau Nuclear Generating Station returned to service after a four year refurbishment which was originally scheduled to take 18 months. The delays associated with the refurbishment and the need to purchase replacement power, the decision to capitalize the costs of this replacement power, and the increase in costs of refurbishing the unit significantly affected NB Power's finances, increasing the amount of its debt.<sup>144</sup>

### 4.7.1 Organization of NB Power

Pursuant to the *Electricity Act* on October 1, 2013, the NB Power group of companies, with the exception of New Brunswick Power Generation Corporation, became a single, integrated crown corporation responsible for the generation, transmission and distribution of electricity throughout New Brunswick. This includes the Electric Finance Corporation, which was created to hold stranded debt, and the New Brunswick System Operator, which were both amalgamated into a new vertically integrated Corporation. New Brunswick Power Generation Corporation remained a wholly owned subsidiary of NB Power, with a name change to New Brunswick Energy Marketing Corporation (NB Energy Marketing).

NB Power is organized into five divisions:

1. Distribution and Customer Service (Distribution) is designated as the standard supplier, responsible for securing adequate capacity and energy to meet customers' needs. Distribution plans, operates and maintains 20,815 km of distribution lines and substations;
2. Generation and Business Development operates and maintains NB Power's non-nuclear generation fleet which consists of 12 hydro, coal, oil and diesel-powered generating stations. It also exports energy to the New England, Quebec, Prince Edward Island and Nova Scotia markets;
3. Nuclear operates and maintains the recently refurbished CANDU 6 - 660 MW reactor at the Point Lepreau Generating Station;

---

<sup>144</sup> Estimates of the cost of refurbishing Point Lepreau range from \$2.4 to \$3.3 billion.

4. The Transmission & System Operator division maintains and operates 49 terminals and switchyards that are interconnected by over 6,849 km of transmission lines ranging in voltage from 69 kV to 345 kV. The Transmission portion of this division is responsible for the design, construction, and maintenance of transmission facilities throughout the province. The System Operator portion of this division is responsible for directing the operation of the transmission facilities and connected generation / load that make up the provincial power system. The System Operator also enables the utilization of the transmission system according to the Electricity Business Rules and the Open Access Transmission Tariff and serves as the reliability coordinator for the Maritimes area including Nova Scotia, PEI and Northern Maine. These responsibilities include maintaining system reliability by controlling and monitoring various elements on the power system and by assuring compliance with NERC reliability standards by controlling energy flows, maintaining required reserves, frequency and area control errors. From 2004 to 2014, the System Operator operated as a separate division; and
5. Corporate Services provides strategic direction, governance and support to the divisions for communications, finance, human resources, legal and governance. It provides these shared services on a cost-recovery basis.

NB Energy Marketing continued in the wholesale merchant function it has performed since 2004. The assets of NB Energy Marketing were transferred to NB Power, with the exception of the licenses and permits necessary to allow NB Energy Marketing to carry out its mandate to import and export energy and certain contracts related to that mandate.

#### **4.7.2 Legislation**

As discussed, the new *Electricity Act* proclaimed in October 2013 reintegrated the former NB Power companies under a single corporate structure subject to regulatory oversight by the Energy and Utilities Board (EUB or Board). NB Power was disaggregated from 2002 to 2004 to better align New Brunswick's electricity sector with emerging competitive electricity markets and the increased level of vertical disaggregation occurring in the sector. The decision to reintegrate NB Power was made to reduce overall costs and recognized that New Brunswick's electricity market was unlikely to become more competitive. Power Advisory believes that as compensation for the loss in competitive market potential from the reintegration, the *Electricity Act* made a number of changes to increase transparency.<sup>145</sup>

The changes come following the release of the *New Brunswick Energy Blueprint (Blueprint)* in late 2011, which set out a 10-year energy policy and 3-year energy action plan for the province. Key principles of the *Blueprint* are:

---

<sup>145</sup> Interestingly, New Brunswick also has a legislative requirement to have open and non-discriminatory transmission access in New Brunswick. This appears to be further effort to compensate for the loss of competitive potential from the reintegration of NB Power.

- Low and stable energy prices;
- Energy security;
- Reliability of the electrical system;
- Environmental responsibility; and
- Effective regulation.

### 4.7.3 The New Regulatory Framework

Part 6 of the *Electricity Act*, entitled Regulation of Electricity, outlines a detailed regulatory framework governing Board approval of NB Power’s rates for both sales of electricity in the Province and the delivery of transmission and ancillary services. That framework is summarized as follows:

1. NB Power is required to file with the Board, at least once every three years, an Integrated Resource Plan (IRP) approved by the Executive Council.<sup>146</sup> The Board doesn’t review the IRP, but uses it as a point of reference for other efforts.
2. Each year, NB Power is required to file with the Board, for information purposes, a 10 year Strategic, Financial and Capital Investment Plan (the “Ten Year Plan”) containing projections of capital expenditures, revenue requirements, load and revenue forecasts and changes in rates for the ten year period covered by the plan. The threshold for capital expenditures is \$50 million, one thousand times the threshold used in Newfoundland and Labrador PUB’s capital budget guidelines. This same \$50 million threshold is used to determine the capital expenditures that are subject to Board approval. The Board may order NB Power to include additional information in any subsequent plan.
3. Each year NB Power is required to apply to the Board for approval of the rates the utility proposes to charge for that year, starting with the 2015/16 fiscal year. This requirement exists even if NB Power does not propose to increase rates in the year. Previously, NB Power could avoid rate hearings before the Board if the increase were 3% or less. The requirement to have rate filings every year may ultimately be viewed as overly burdensome, particularly given the potential length of any associated hearing process. The Board approves those rates that it finds to be just and reasonable. Not surprisingly, consideration of whether rates are just and reasonable needs to consider the implications of any government directives and there are no constraints on the government’s ability to issue such directives.

The Board is required to establish just and reasonable rates based on the revenue requirements of NB Power, but in doing so is required to take into consideration, among other things, the IRP, the 10 Year Plan, and the policy set out in section 68 of the *Electricity Act*. Section 68 states that the Government of New Brunswick policy is that NB Power provide a secure, economically sustainable and least cost supply of electricity to its customers in New Brunswick. In furtherance of the goals

---

<sup>146</sup> The *Electricity Act* specifies that the IRP include: (1) a load forecast for the planning period; (2) demand-side management and energy efficiency plans that it considered and has chosen to implement; (3) supply-side options that it considered and has chosen to implement; (4) key assumptions relied upon in developing the IRP; and (5) a description of the stakeholder consultations.

of security and economic sustainability, the policy states that rates for New Brunswick customers should be established on the basis of annually forecasted costs, and should provide sufficient revenue to NB Power to earn a just and reasonable return, in the context of NB Power's objective to earn sufficient income to achieve a capital structure of at least 20% equity. NB Power plans to achieve that target through the reduction of debt by \$1 billion by 2021.

Section 68 of the *Electricity Act* provides that the rates charged by NB Power for sales of electricity within the Province (i) should be established on the basis of annually forecasted costs for the supply, transmission and distribution of the electricity, and (ii) should provide sufficient revenue to the Corporation to permit it to earn a just and reasonable return, in the context of the Corporation's objective to earn sufficient income to achieve a capital structure of at least 20% equity. The Act also specifies that NB Power's sources and facilities for the supply, transmission and distribution of electricity within the Province should be managed and operated in a manner that is consistent with reliable, safe and economically sustainable service and that will (i) result in the most efficient supply, transmission and distribution of electricity, (ii) result in consumers in the Province having equitable access to a secure supply of electricity, and (iii) result in the lowest cost of service to consumers in the Province. In addition, consistent with the policy objectives set out above and to the extent practicable, rates charged by NB Power for sales of electricity within the Province shall be maintained as low as possible and changes in rates shall be stable and predictable from year to year.

The Board also is responsible for approving reliability standards. The Board's approval of those standards must consider: (1) the potential impact of the approval or the retirement of a standard on the reliability of the bulk power system; (2) the potential cost and benefits of the approval or the retirement; (3) the public interest, and (4) any other factors that the Board considers relevant. The Board also has compliance monitoring and enforcement responsibilities. Other than its role vis-à-vis these reliability standards there are no specific obligations on the Board with respect to ensuring the reliability of the electricity system. However, NB Power does have an obligation to maintain "the adequacy and reliability of the electricity system."

Various Business Rules complement and supplement the Open Access Transmission Tariff (the "Tariff"), and facilitate the reliable operation of the Integrated Electricity System (the "IES") and adherence to Board Approved Reliability Standards. The operation of the IES is governed by the *Electricity Act*, the Tariff, and the Business Rules. The authority and scope of the Electricity Business Rules (the "Business Rules") are established in the *Electricity Act*.

The purpose of the Business Rules is to clarify and provide interpretation regarding the rights and obligations between NB Power as the Transmission Provider and transmission system users with respect to the administration of the Tariff, the operation of the IES, and functions performed by the Transmission Provider with respect to electricity systems outside of New Brunswick. The Business Rules define the administrative practices for the sale and provision of Transmission Services.

The *Electricity Act* provides broad discretion to the Board under a public interest standard.<sup>147</sup>

As part of a series of new objectives outlined in the *Electricity Act*, a merit-based process for recruiting and selecting candidates for NB Power's board of directors, as well as for the President and Chief Executive Officer was introduced. As part of these changes in 2013, NB Power implemented a new and independent process for identifying potential new board members. The *Electricity Act* stipulates that the process for nominating directors shall be to “use a merit-based and objective approach, ensure that the board of directors as a whole has the necessary skills and qualifications to carry out its functions, and provide to the Lieutenant-Governor in Council a description of the recruitment, assessment and selection processes used and the results of those processes”. As implemented, the process involves the use of an independent search firm to recruit board members through a competitive process, helping the company to build a roster of new board members with varied skills and experience to assist in leadership on the governance and strategic direction of the company. The Lieutenant-Governor of New Brunswick is responsible for approving new board members.

The Executive Council may at any time issue directives in writing to the Corporation that must be taken into consideration by the board of directors of the Corporation. In addition the Lieutenant Governor may issue regulations regarding a wide range of items including dismissal of the President and CEO of NB Power, the process for nominating Directors of NB Power, prescribing a range for NB Power’s return on equity and capital structure, and respecting reliability standards.<sup>148</sup>

The *Electricity Act* grants NB Power the exclusive right to sell electricity to customers in New Brunswick, with the exception of customers served by the municipal utilities in Edmundston, Perth-Andover and Saint John.<sup>149</sup> Previously, wholesale competition was allowed which allowed sales to municipal electric utilities. NB Power also is granted the exclusive right to build new transmission lines in the province and may do so via partnerships or joint ventures with other companies in order to share project costs and risk.

#### **4.8 Prince Edward Island**

PEI’s principal utility is Maritime Electric, which is owned by Fortis. Maritime Electric has a legislated monopoly on distribution in the province other than in Summerside, and has approximately 77,000 customers. Maritime Electric sources most of its electricity through third-party supply contracts. Additionally, the utility owns some generation. The City of Summerside operates the only municipally-owned utility on the Island, and has approximately 6,900 customers.

---

<sup>147</sup> Specifically, Section 131 of the *Electricity Act* provides that “Any order or decision of the Board made under this Act or the regulations is subject to any terms or conditions that the Board considers necessary in the public interest.” Public interest is not specifically defined in the *Electricity Act*.

<sup>148</sup> This includes the all encompassing provision: “respecting any other matter that the Lieutenant-Governor in Council considers necessary or advisable to carry out effectively the intent of this Act.”

<sup>149</sup> Those selling electricity to municipal utilities are able to continue to do so as long as that contractual relationship is maintained.



PEI is largely dependent on imports. However, the province is developing wind generation projects, and it is expected there will continue to be an increased use of renewables. Historically, the cost of electricity in PEI has been higher than other Canadian provinces as a result of the Island's lack of coal, oil, gas, and hydroelectric resources combined with costs associated with importing electricity.<sup>150</sup>

#### **4.8.1 Island Regulatory and Appeals Commission**

Regulatory oversight of Island utilities is the responsibility of the Island Regulatory and Appeals Commission (IRAC). IRAC was established in 1991 following the amalgamation of the former Public Utilities Commission, Land Use Commission and the Office of the Director of Residential Rental Property. IRAC reports to the Legislative Assembly of Prince Edward Island, through the Minister of Education and Early Childhood Development. IRAC's principal control is over Maritime Electric, and has jurisdiction in other sectors as well, including the petroleum distribution sector and automobile insurance.

#### **4.8.2 Legislative Review**

The *Electric Power Act*, 2004, is the primary legislation used to govern the supply and delivery of electricity in PEI. The Act identifies IRAC as the agency that receives and rules on submissions made by Maritime Electric and other public utilities concerning electricity. Prior to the enactment of the *Electric Power Act*, the *Maritime Electric Company Limited Regulation Act*, 1994 required Maritime Electric to maintain its rates within 10% of NB Power rates.

The *Island Regulatory and Appeals Commission Act* provides IRAC with its structure and authority. This Act specifically references the regulation of utilities under *Electric Power Act* as a function of IRAC.

In 2009, the *Energy Corporation Act* established the Prince Edward Island Energy Corporation, which is responsible for pursuing and promoting the development of generation, transmission and distribution of energy within the province. This has largely involved the development of several wind projects.

The *Renewable Energy Act*, 2012 requires Island utilities to obtain at least 15% of the energy that they sell in a calendar year from renewable energy sources. The Act also requires that the utilities submit an annual report to the Minister responsible for energy with the actual amounts of renewable energy and all energy sold. Finally, the Act provides Government with control over the development of renewable energy in the province, both directly and through the following regulations:

- Development Permit Regulations;
- Minimum Purchase Price Regulations;

---

<sup>150</sup> Costs include infrastructure, line losses, and transmission fees.

- Net-Metering System Regulations; and
- Renewable Energy Designated Areas Regulations.

#### **4.8.3 Maritime Electric’s Open Access Transmission Tariff**

In 2006, Maritime Electric drafted an OATT to provide nondiscriminatory access for wind developers and other potential users. As the Island’s only transmission provider, the requirement for Maritime Electric to have an approved OATT became necessary with the development of independently owned wind power electricity generation facilities, which provided electricity to markets off-island. These wind farm developers required access to transmission services both on and off island.

On December 13, 2006, Maritime Electric filed an OATT application with IRAC. The application was subsequently re-filed on October 3, 2007<sup>151</sup> following a stakeholder review process which resulted in several changes to the original application. The tariff and pricing methodology used by Maritime Electric followed NB Power’s approach, which in turn was based on FERC’s Pro Forma Tariff. The OATT was approved by IRAC effective June 30, 2008 as an interim tariff rate. The interim tariff was updated on July 30, 2009.<sup>152</sup>

Under the Maritime Electric OATT, disputes<sup>153</sup> between a transmission customer and the transmission provider involving transmission service under the OATT are referred to a designated senior representative of the Transmission Provider and a senior representative of the Transmission Customer for resolution on an informal basis. In the event the designated representatives are unable to resolve the dispute within 30 business days, the dispute will be submitted to arbitration.

#### **4.8.4 PEI Energy Accord**

Because of the Island’s reliance on imported energy, customers have faced increasing costs of electricity and price spikes. In November 2010, the Province unveiled its PEI Energy Accord (Accord), with the following goals:

- Reduce the cost of electricity;
- Stabilize prices; and
- Expand renewable, locally owned energy to reduce PEI’s reliance on imports.

The Accord identified a number of short term measures towards these goals, including increasing publicly owned wind power and securing a new PPA with New Brunswick Power to supply over half of PEI’s short-term energy requirements.<sup>154</sup> The Accord also called for the establishment of an

<sup>151</sup> Filing is available here: <http://www.irc.ca/infocentre/documents/ue20935-MECL-OATT-Oct-2007.pdf>.

<sup>152</sup> See interim and updated tariff’s here:

[https://secure.maritimeelectric.com/mesa/docs/MECL\\_Updated\\_OATT\\_Rates.pdf](https://secure.maritimeelectric.com/mesa/docs/MECL_Updated_OATT_Rates.pdf).

<sup>153</sup> Excluding applications for rate changes or other changes to the OATT, or to any Service Agreement entered into under the OATT, which shall be presented directly to IRAC for resolution.

<sup>154</sup> Short term being 5 years from the establishment of the Accord. See page of 3 of <http://www.gov.pe.ca/photos/original/energyaccord.pdf>.

Energy Commission which would examine longer-term structural issues in support of the aforementioned goals.

#### **4.8.5 PEI Energy Commission**

In 2011, the PEI Energy Commission was asked to examine and provide advice on the current status and future direction of Prince Edward Island's electricity system. The final report entitled *Charting Our Electricity Future*<sup>155</sup> was published in September 2012, and contained the following key recommendations:

- Allow Maritime Electric to continue as the Island's primary electric utility with the proviso that Government begins negotiations to acquire Maritime Electric's ownership stake in the generation component of the supply system;
  - The *Electric Power Act* should be amended to require that Maritime Electric maintain its equity stake at no less than 35% and no more than 40%;
  - The Commission recognizes the fact that Summerside Electric is already a publicly owned utility and as such, believes that there is no need to change the ownership structure or involve Government in utility operations. However, should Summerside Electric seek Government involvement, be it for PPA negotiations or for other matters, that option should be available;
- Return responsibility for Demand Side Management (DSM) initiatives to Island electric utilities and establish regulatory oversight of DSM by IRAC through the *Electric Power Act*; and
- Establish a "consumer advocate for electricity" to represent individual ratepayers and help facilitate the participation of other interested parties at regulatory hearings.

The Commission also concluded that an opportunity exists to improve the province's regulatory system via changes to the IRAC. It was recommended that a new panel be established with its members dedicated solely to electricity regulation and selected on the basis of professional qualifications and business experience. The new panel would be structured to operate independently of IRAC's standard quasi-judicial process and adopt an approach that is more directly involved in all aspects of the Island's electricity supply system.

#### **4.9 Nova Scotia**

Nova Scotia Power Inc. (NSPI) is the largest electric utility in the province, serving approximately 95% of the province's 500,000 customers. NSPI owns virtually all the transmission and the vast majority of the distribution assets in the province as well as a significant portion of the generation. NSPI also purchases a considerable amount of renewable energy from independent power producers, and there are several municipal electrical utilities that distribute electricity to customers in their communities. An investor owned utility, NSPI is a vertically-integrated public utility incorporated under the *Nova Scotia Companies Act* and regulated by the Nova Scotia Utility and

---

<sup>155</sup> Report is available here: [http://www.gov.pe.ca/photos/original/NRGCommish\\_13.pdf](http://www.gov.pe.ca/photos/original/NRGCommish_13.pdf).

Review Board (NSUARB). NSPI is the successor to the crown corporation, Nova Scotia Power Corporation (NSPC), and is the principal subsidiary of Emera Inc.<sup>156</sup>

The Nova Scotia Power System Operator is responsible for and manages the wholesale electricity market and oversees the operation of the provincial electricity grid. Financially, the system operator is part of NSPI, however consistent with FERC Order 889 it is operationally and functionally separated from the merchant segments of NSPI and must adhere to a NSUARB approved Standard of Conduct to ensure its independence from NSPI's other business units.

The Nova Scotia Department of Energy (DOE) is responsible for setting the policy and legislative framework for Nova Scotia's electricity system. The DOE is charged with advising on all aspects of energy policy for the province, including electricity, natural gas, and oil.

Historically, Nova Scotia relied on burning oil to supply the majority of the province's electricity. With the dramatic increase in oil prices in the 1970's, Nova Scotia Power switched from imported oil to Cape Breton coal as the primary source of electricity generation. In response to an Equivalency Agreement with the federal government, which requires that Nova Scotia achieve equivalent emission reductions as would be realized by Federal Regulations for the reduction of carbon dioxide emissions from coal-fired generation of electricity, changes are currently underway in the province to reduce the reliance on coal. Under provincial policy increasing renewable electricity generation is an important part of this strategy. Concerns surrounding rate increases in the electricity sector currently exist in the province. Rising fuel costs and an aging infrastructure along with the addition of renewable energy sources have contributed to rising electricity costs in Nova Scotia.

#### **4.9.1 Legislative Review**

The *Energy Resources Conservation Act*, 1989 regulates conservation and appraises the reserves and production capacities of energy resources in Nova Scotia. The Act ensures efficient practices in the exploration and development, production, transmission and transportation of energy resources; provides for the economic, orderly and efficient development in the public interest of energy resources; appraises the reserves and production capacities of energy resources; appraises the need for energy resources and appraises markets outside the province for its energy resources.

The *Public Utilities Act*, 1989 outlines the roles and responsibilities of the NSUARB. Pursuant to the Act, the NSUARB exercises general supervision over all electric utilities operating as public utilities within the province. This includes rate setting, tolls and charges, and regulations for the provision of service. This supervision also includes oversight of any public utility's capital expenditures in excess of \$250,000. The NSUARB is responsible for directing NSPI to conduct integrated resource planning processes and produce Integrated Resource Plans.

---

<sup>156</sup> Emera Incorporated was formerly called Nova Scotia Power Holdings Inc. The name was changed in 2000.

The NSUARB also has general supervisory power over and sets rates, tolls, charges, and regulations for the following:

- Tramways;
- Bus companies operating as utilities;
- Natural gas utilities;
- Steam or geothermal heat utilities; and
- Water utilities.

In January, 1992 the Government of Nova Scotia announced its intention to sell a controlling interest in NSPC to private investors, which would privatize the corporation. This was due in-part to the Crown corporation's high level of debt. The *Nova Scotia Power Privatization Act, 1992* provided for the reorganization of NSPC and the creation of NSPI.

The *Electricity Act*,<sup>157</sup> 2004 deregulated the wholesale electricity market in Nova Scotia allowing wholesale customers to purchase electricity from any competitive supplier.<sup>158</sup> In 2010, Section 5 of the *Electricity Act* was amended to include the *Renewable Electricity Regulations*,<sup>159</sup> which requires that a person who sells or supplies electricity to a customer shall comply with the Renewable Energy Standards set out in the regulations. These regulations set out the legal requirements for how much of the overall generation will be made up of renewable sources moving forward. The Renewable Energy Standards are as follows: 15% by 2011, 20% by 2013, 25% by 2015, and 40% by 2020. The increase from 25% to 40% in 2020 will be enabled by purchases from Muskrat Falls. Nalcor executed various agreements with Emera for the construction of the Maritime Link and the provision of energy and capacity from Muskrat Falls as discussed in Section 2.4.1. In return for bearing 20% of the cost of building Muskrat Falls and associated transmission facilities, Emera Inc. will receive 20% of the energy (about .9 million MWh per year) from Muskrat Falls for use in Nova Scotia.

In 2005, the *Public Utilities Act* was amended by adding a new section<sup>160</sup> which provides details on the NSUARB's ability to appoint a person to act as a consumer advocate in hearings before the NSUARB. This legislation indicates that the consumer advocate shall participate in all aspects of the hearing and represent the interests of residential customers as a full intervenor with power to enter into settlement agreements with other parties. The province also has a consumer advocate who represents the interests of small businesses. Currently there is no formal office of the Consumer Advocate, with the Government appointing an individual as Consumer Advocate who engages consultants when necessary to provide support, similar to Newfoundland and Labrador.

The *Electricity Reform Act, 2013* provides for certain suppliers to be able to sell, and certain customers to be able to purchase, renewable electricity. The legislation served as a primary step in

---

<sup>157</sup> Act is available here: <http://nslegislature.ca/legc/statutes/electricity.pdf>.

<sup>158</sup> It was at this time that NPSI offered transmission under an open access transmission tariff.

<sup>159</sup> <http://www.novascotia.ca/just/regulations/regs/electrenew.htm>.

<sup>160</sup> [http://nslegislature.ca/legc/bills/59th\\_1st/3rd\\_read/b162.htm](http://nslegislature.ca/legc/bills/59th_1st/3rd_read/b162.htm).

the provincial government's plan to review Nova Scotia's electricity policy and created local investment opportunities for renewable electricity providers. The Act also laid the groundwork for the first public consultation on the province's electricity market in 13 years. As part of the consultation process, public presentations and workshops were held in the Fall of 2014, with a deadline for submitting public input of early December 2014. A draft review report which will present findings from the consultation process was released in February 2015.

#### **4.9.2 NERC Reliability Obligations**

As per the Memorandum of Understanding<sup>161</sup> (MOU) between the NSPI, the Northeast Power Coordinating Council, and NERC, NERC compliance is mandatory in Nova Scotia. NSPI is responsible for planning for and maintaining reliable electricity service to all loads in the province, and for reviewing and implementing NERC standards under the supervision of the NSUARB. The NSUARB is responsible for monitoring compliance and accepting compliance information and recommendations from NERC. The NSUARB has the authority to stay or revoke the operation of a reliability standard in Nova Scotia and refer it back to NERC or the NPCC for further consideration.

#### **4.9.3 Integrated Resource Plans**

NSPI uses Integrated Resource Plans (IRPs) to forecast and plan, producing long-term plans to outline how the province's electricity requirements will be met. In 2006 and 2007 a provincial IRP was developed by NSPI in collaboration with the NSUARB and in consultation with stakeholders. The planning horizon considered for this IRP was 2007-2029. The Final IRP Report with recommendations was filed with the NSUARB in July 2007. The Report revealed that the province's energy requirements and adherence to applicable legislation and regulations could be met through investment in demand side management programs and renewable generation procurement, and through upgrades to NSPI's existing generation fleet.

On February 25, 2009, the UARB directed<sup>162</sup> that the 2007 IRP be updated, using the same approach as in 2006/2007. NSPI's 2009 IRP Update focused on incorporating new information in order to determine the changes needed to the plan as outlined in the 2007 IRP Reference Plan. An updated IRP Action Plan was therefore developed, identifying conservation and energy efficiency programs, additional renewables such as wind, hydro and biomass, and updates to existing energy generation facilities as important components for NSPI's plans over the next 25 years.

Initiated in 2014, NSPI underwent another integrated resource planning process. The 2014 IRP captures supply and demand changes that have been seen in the province since the 2009 IRP was completed. These changes include:

- A significant increase in intermittent renewable energy;

---

<sup>161</sup> MOU was established on May 9, 2010. See

[http://www.nerc.com/FilingsOrders/ca/Canadian%20mous%20DL/NSPI\\_NERC\\_NPCC\\_MOU\\_executed\\_20100511.pdf](http://www.nerc.com/FilingsOrders/ca/Canadian%20mous%20DL/NSPI_NERC_NPCC_MOU_executed_20100511.pdf)

<sup>162</sup> UARB Correspondence to NSPI, February 25, 2009.

- Reductions in industrial electricity use; and
- Stringent environmental requirements related to generating electricity.

NSPI filed the Final IRP Report<sup>163</sup> with the NSUARB on October 15, 2014.

#### **4.9.4 Efficiency Nova Scotia**

Efficiency Nova Scotia is a non-profit organization incorporated under the *Efficiency Nova Scotia Corporation Act* in January 2010. It was established to implement demand-side management programs in the province, recognizing that Nova Scotia Power's incentive to implement such measures was muted by ratemaking practice. Efficiency Nova Scotia's budget is funded by a surcharge on electricity customers' bills, the Demand-side Management Fund, with annual expenditures subject to approval by the UARB. In addition, Efficiency Nova Scotia entered into an agreement with the province to implement specific non-electricity conservation and energy efficiency programs. In 2013 its total budget was about \$60 million, with over 75% funded by charges on customer's electricity bills (i.e., the Demand-side Management Fund), with the remaining costs paid by participating customers.

#### **4.10 Summary and Conclusions**

Most utilities in Canada are faced with the challenges associated with replacing aging infrastructure, meeting future growth in customer requirements, and managing rate increases, while ensuring favourable access to needed capital. These challenges can be most significant for Crown utilities that are highly levered and as a result have reduced cash flow to fund such investments.

Table 7 summarizes the key elements of the various provincial electricity sectors across Canada. This includes the role of the provincial regulator in rate setting, overseeing utility infrastructure investment and resource planning. The framework for protecting customers is also reviewed and distinguishes between wires, which includes transmission and distribution, and wholesale prices.

The three predominately hydroelectric systems devote considerable resources to optimizing the use of water so as to maximize the value of output. In Manitoba where there's relatively limited storage, which requires optimizing the storage that is available as well as river flows. In Québec, more attention is paid to short-term trade opportunities and using the province's significant storage capability to maximize the value from such trade. The storage capability of Newfoundland and Labrador's hydroelectric reservoirs on per MW basis is much closer to that offered by Québec than Manitoba.

There are a range of viable and effective structures for electricity sectors employed across Canada. Those employed in the predominately hydro jurisdictions (i.e., BC, Manitoba and Québec) are among the most relevant to Newfoundland and Labrador as it becomes a predominately hydroelectric system. Both BC and Québec have opted for heritage pools or contracts, which

---

<sup>163</sup> Final 2014 IRP available here:

<http://www.nspower.ca/site/media/Parent/20141015%202014%20IRP%20Final%20Report.pdf>.

effectively ring-fence existing facilities and guarantee the benefits of low cost energy from these facilities to customers. In Québec the structure results in the risks and rewards of new facilities being borne by the shareholder, rather than customers. Heritage pools are discussed further in Section 6.3.5 of this report.

These predominately hydroelectric utilities have pursued different strategies for serving domestic customers and pursuing export opportunities. These differences are dictated in part by the differences in the hydraulic resources, market access, and market volatility. The significant storage capability of Hydro-Québec has allowed it to participate opportunistically in these markets and enhance the value of these hydro facilities. Strategic considerations associated with different approaches to export markets are reviewed further in Section 6.3.1.



**Table 7: Summary of Electricity Market Structures in Canadian Provinces**

<b>Electricity Sector Overview</b>	BC	Alberta	Saskatchewan	Manitoba	Ontario	Quebec	New Brunswick	Nova Scotia	PEI	NL
Customers (1000's)	1,800	1,700	490	555	4,500	4,100	400	500	84	290
Residential Rate (¢/kWh as of 4/14)	9.71	11.88	13.95	7.89	13.62	7.06	12.06	16.03	15.24	11.34
Wholesale Price Setting	Regulated	Market	Regulated	Regulated	Contract	Regulated	Regulated	Regulated	Regulated	Regulated
<b>Industry Structure</b>	Crown & Inv.	Inv. & Muni	Pred. Crown	Crown	Crown & Muni	Crown	Crown & Muni	Pred. Inv.	Pred. Inv.	Crown & Inv.
<b>Utility Ownership</b>	Vertically	Disaggregated	Vertical	Vertical	Disaggregated	Disaggregated	Vertical	Vertical	Vertical	Vertical
<b>Regulator Scope</b>	No	Wires & Def.	Review	Recommends	Wires & Def.	Wires	Yes	Yes	Yes	Yes
Rates	No	Wires	No	No	Wires	No	Yes	Yes	Yes	Yes
Investment	No	No	No	No	No	Distributor	Considered	Yes	No	Not Exercised
Planning	Proposed	No	No	No	No	No	No	Yes	No	Not Exercised
<b>Customer Protection</b>	COS Reg	COS Reg	COS Reg	COS Reg	PBR Reg	COS Reg	COS Reg	COS Reg	COS Reg	COS Reg
Wires	COS Reg	Market	COS Reg	COS Reg	Contract	Contract	COS Reg	COS Reg	COS Reg	COS Reg
Whole sale Price	COS Reg	Market	COS Reg	COS Reg	Contract	Contract	COS Reg	COS Reg	COS Reg	COS Reg
<b>Ancillary Institutions</b>										
Consumer Advocate	No	Yes	No	No	No	No	Previously	Yes	Proposed	Yes
Independent System Operator	No	Yes	No	No	Yes	No	Previously	Separate	No	No

Source: Power Advisory

Notes: Alberta residential rate is for Edmonton. Ontario residential rate is average for Toronto and Ottawa. NL residential rate is for IIS customers.

Def. = default service which is provided to residential customers that don't elect to be served by a competitive retailer.

## **5. Assessment of Agencies with Oversight over Electricity Sector**

This section provides a performance assessment of the PUB and Consumer Advocate and draws upon the jurisdictional review to assess the underlying performance of these two entities.

### **5.1 Assessment of the PUB**

The PUB issues an Annual Report which reviews its mandate and annual performance in accordance with the *Transparency and Accountability Act*. The Act requires that the PUB submit annual performance reports to the House of Assembly on its success in achieving the various objectives and measures outlined in its multi-year performance-based activity plan. This is a best practice.

The PUB's 2013-14 Annual Report indicates that its strategic priorities include enhancing regulatory efficiency and effectiveness and corporate capacity. These priorities are appropriate and reasonable for the PUB. Every regulator should be focused on efficiency and effectiveness since regulation is a means to an end and the costs of regulation are just that, a cost. The PUB's focus on corporate capacity is particularly appropriate for a small jurisdiction, with limited regulatory resources. However, as discussed further below there is evidence that the PUB's regulatory efficiency is an issue.

The 2013-14 Annual Report focuses on outlining efforts to further these priorities. This Annual Report indicates that the PUB furthered its regulatory efficiency and effectiveness priorities and achieved efficiencies and cost savings through enhanced communication with its primary clients and technology improvements in the hearing rooms and in administrative support systems. In addition, the PUB completed a review of the Power Outage Reporting Policy; conducted a review and analysis of the Document Filing Guidelines, with new guidelines introduced; commenced a review of the Capital Budget Filing Guidelines and Quality of Service Reviews, but both were put on hold given ongoing proceedings and constraints associated with ex-parte communications. Appropriately, these reviews were performed from a holistic perspective that considered the PUB and regulated entity's costs.

The PUB's priority of enhancing its corporate capacity recognizes its relatively small size and the challenges posed by staff turnover given the specialized knowledge and expertise required to perform these functions. We were informed in our initial meeting with PUB staff that two of the most senior staff members in the regulatory and advisory services section were scheduled to retire within the next twelve months, increasing the appropriateness of the PUB's focus on enhancing corporate capacity. We understand that the PUB has focused on expanding and developing staff resources in light of these retirements. This is a critical issue which warrants continued attention given the small staff complement focused on regulatory and advisory services and the PUB's reliance on consultants who don't provide the same permanency as staff.

The PUB is also focused on communications with stakeholders, in particular its website as the portal for this communication. This is an important role for the PUB and critical to the effective

functioning of the province’s electricity sector. Given the PUB’s relatively small size we recognize that there may be a challenge in maintaining a website that meets the needs of stakeholders.<sup>164</sup> However, given the volume of information submitted to the PUB and the importance of easy access to this information to stakeholders and their effective participation before the PUB, devoting sufficient resources to the website is critical. Therefore, it is important that the PUB website continue to receive appropriate attention. Having a search function on the website is a best practice, which would significantly benefit stakeholders. In addition, improving the organization of the website would also help stakeholders navigate it.

The PUB satisfies the governance objectives to ensure financial and organizational autonomy made in the report on Governance best practices referenced in Section 6.1. Specifically, the report recommends that agencies should have sufficient and predictable financial resources to fulfill their functions; should obtain their funds through rate levies collected from customers; and have control over their internal organization and personnel decisions. One departure, which is common across most regulators, is that the CEO and Chair is appointed by Government. Power Advisory doesn’t believe this to be a meaningful departure from best practices.

Table 8 compares the operating budgets, number of commissioners and staff of the PUB with various other Canadian regulators.<sup>165</sup> When evaluating these budgets consideration also needs to be given to the different mandates of regulators in the different jurisdictions. The regulators in these other jurisdictions also regulate natural gas service. BC, Manitoba, and Nova Scotia regulate automobile insurance, similar to Newfoundland and Labrador. Ontario and Alberta regulators have broad mandates and responsibilities given the structures of their electricity markets and the relatively numerous entities which they oversee.

**Table 8: Operating Costs and Staffing Levels at Public Utility Commissions across Canada**

	NL PUB	BC Utilities Commission	Manitoba Public Utilities Board	Ontario Energy Board	Quebec Regie de l'energie	Alberta Utilities Commission	Nova Scotia Utility & Review Board
<b>Total 2013 Operating Costs</b>	\$ 3,159,485	\$ 7,619,441	\$ 3,499,000	\$ 35,595,501	\$ 14,209,226	\$ 33,475,797	\$ 9,449,000
<b>Expenditure per Capita</b>	6.00	1.66	2.77	2.63	1.74	8.32	10.04
<b>Full Time Commissioners</b>	4	1	1	6	7	8	8
<b>FTE Commissioners</b>	4	5.5	2	9	8	9.5	8
<b>FTE Staff (excl commissioners)</b>	13	38	7	171	82	135	32

Source: Independent Review of the BCUC, Interim Report and NL Board, 2013-2014 Annual Report

The operating costs shown for the PUB include hearing costs which are effectively charged to the applicant. If these hearing costs were deducted from the operating cost total the per capita costs of

<sup>164</sup> Specifically, maintaining such a website can require special skills that a smaller organization may not possess. However, it is also possible to contract for such services.

<sup>165</sup> The operating expenses for the PUB are net of the hearing costs of the Consumer Advocate.

the PUB would be \$4.64.<sup>166</sup> A comparison of the expenditures per capita for the PUB to those for other regulators across Canada doesn't suggest that the PUB is under resourced. However, Power Advisory believes that there are what are effectively economies of scale with any regulatory function, so the smaller size of the Newfoundland and Labrador electricity sector is likely to increase what would be viewed as an efficient operating cost. Furthermore, a review of the PUB's organizational chart indicates that there are only five staff in the Regulatory and Advisory Services function and one attorney who serves as legal counsel. These staff positions are supplemented by outside legal counsel and an engineer who have had been close to full time given recent demands. With the recent case load (e.g., NLH GRA, Outage Inquiry, and Capital Budget Applications including two major supplementary applications), Power Advisory understands that this staff complement was fully taxed. However, PUB staff indicate that they have sufficient resources and that they have been able to obtain adequate resources as demands require. PUB staff did indicate that an expansion of their responsibilities with the interconnection of Newfoundland to the North American grid is likely to require additional resources (e.g., if the PUB had responsibility with respect to approving reliability standards).

Given the relatively small size of Newfoundland and Labrador's electricity sector and the corresponding limited resources available to it for this task, the PUB has distinct challenges associated with efficiently and capably regulating the sector. With information asymmetries between regulators and the regulated entities, the resources available to the PUB is an important issue. The PUB has addressed this issue by retaining senior staff and engaging consultants when specialized expertise is required.

One measure of an organization is the degree of self-reflection and the appropriateness of the issues identified. The PUB's 2013-14 Annual Report indicates that it is sufficiently inwardly focused and geared towards enhancing its effectiveness. Furthermore, the PUB understands how it will be measured: "Providing clear and well-reasoned decisions and timely information is an important aspect of maintaining the trust of consumers, the public and stakeholders."<sup>167</sup>

Of greater importance to the regulated community is regulatory predictability and certainty.<sup>168</sup> This is a critical indicator of the quality of regulation and is important to ensuring that the regulatory bargain serves both customers and regulated entities well. The degree of predictability and certainty affects utility cost of capital, with customers benefiting from lower costs of capital.

In assessing the performance of the PUB it is useful to evaluate its performance with respect to the oversight and regulation of NP and NLH separately. The PUB has regulated NP for a relatively long-time. NP's business and operations are relatively straightforward. Furthermore, NP devotes

---

<sup>166</sup> Per capita is calculated in terms of the total population, not ratepayers.

<sup>167</sup> PUB, 2013-14 Annual Report, p. 13

<sup>168</sup> Interestingly, one of the Newfoundland and Labrador industrial customers that we contacted indicated that it was also concerned with predictability, but that it viewed predictability more in terms of future rates. This customer expressed concern with unanticipated changes in rates as well as the apparent regulatory discord between NLH and the PUB.

considerable resources to its regulatory function with a Vice President of Regulation & Planning, one of three executives that reports to the President, and a staff of five. NP's executes well with respect to its regulatory responsibilities. The net result is that the PUB's oversight of NP is effective and efficient and results in decisions which generally provide predictability and certainty.

The PUB's experience with NLH is very different. First of all, the PUB has more limited experience regulating NLH given that it only became subject to full PUB regulatory oversight under the *EPCA* and there have been relatively few GRAs filed by NLH over this time. NLH's business is distinctly different than NP's, and in many ways more complex; it is primarily a generation and transmission company, but which also operates distribution networks in remote areas of the province. NLH's 2013 GRA is indicative of the differences with respect to the PUB's oversight. This GRA was filed in July 30, 2013, but was suspended in June 2014 after NLH provided notice that it would be filing an amended application in the fall of 2014. The new filing was needed as it became apparent that another GRA filing would have been required soon after a PUB order was issued in the current GRA since it was based on a 2013 test year.<sup>169</sup> This was after over 1,000 information requests had been issued by nine intervenors. This number of information requests and the need to refile an amended application is not consistent with an efficient regulatory proceeding. One contributor to the refiling was the decision to employ a 2013 test year, for a filing in the middle of the test year. This is an indication of another challenge in this relationship, regulating a Crown utility and the more complicated relationship that ensues. For example, NLH's filing had to also conform with direction from its shareholder, which specified the 2013 test year. Power Advisory understands that there were a number of different filing dates and directives regarding filing dates, but that these changed to reflect changes in the regulatory calendar and the need to resolve other issues, e.g., treatment of the balance in the Rate Stabilization Plan. Another factor which likely contributed to these inefficiencies is the fact that NLH's last GRA was in 2007. This increased the scope and number of IRs and potentially affected NLH's ability to respond expeditiously. For example, this was the first GRA where issues associated with NLH's relationship in Nalcor were subject to regulatory scrutiny. Finally, there were nine intervenors participating in the proceeding, which undoubtedly contributed to the number of information requests.

Another consideration in assessing the performance of the PUB is the fact that a PUB decision was remanded by the Newfoundland and Labrador Court of Appeals (Court) and that a second decision on this very same matter was overturned.

As an adjudicatory agency the degree to which its decisions stand up when appealed is an important measure of its performance and an indication of the predictability and certainty of regulation. In Order No. P.U. 25 (2010) the PUB found that a balance of almost \$80 million, which had accrued in the Rate Stabilization Plan (RSP) was due solely to industrial customers. This decision was appealed by NLH and the Consumer Advocate who argued that the PUB too narrowly defined its

---

<sup>169</sup> Recall that the *EPCA* calls for rates to be based on "forecast costs", which implies a forward test year. Section 3 (a)

jurisdiction. The PUB argued that “the fact that the rates for Hydro’s non-industrial customers had been made final for the period 2008 to 2010 barred consideration of any claim of entitlement to the systems savings by non-industrial customers when settling the final rates for industrial customers for the three year period affected by the 2009 GRA.”

The Court found that

“Fundamentally, what is at issue in this appeal is whether certain savings generated in a rate stabilization plan established by the Board can be shared among all residential and industrial power consumers on the island portion of the province or only among industrial customers. The appeal engages the interpretation of the Board’s governing legislation, in particular, s. 87 of the PUB Act, and whether the Board erred in determining it did not have jurisdiction to allocate savings to customers other than certain industrial customers.”<sup>170</sup>

The Court noted that “in considering the extent of the Board’s powers under the *PUB Act* reference must be made to s. 118 which states:

118.(1) This Act shall be interpreted and construed liberally in order to accomplish its purposes, and where a specific power or authority is given the board by this Act, the enumeration of it shall not be held to exclude or impair a power or authority otherwise in this Act conferred on the board.

(2) The board created has, in addition to the powers specified in this Act, all additional, implied and incidental powers which may be appropriate or necessary to carry out all the powers specified in this Act.”<sup>171</sup>

Furthermore, the Court noted that *EPC Act* called for the PUB to apply tests which are consistent with “generally accepted sound public utility practice”.<sup>172</sup>

In its decision the Court noted that “current industrial customers were paying approximately \$20 million in annual electricity costs. However, \$68 million of load variation transfers were accumulating as system savings on an interim basis since January 1, 2008 which represented approximately three and a half times the annual electricity costs of the current industrial customers.”<sup>173</sup> Therefore, if the RSP balance were to be rebated to industrial customers over a period of less than three years they would have negative rates, which is a clear indication of the magnitude of the impact and suggested that the PUB’s proposal represented a windfall to industrial customers, which caused NLH, NP and the Consumer Advocate to appeal the decision.

---

<sup>170</sup> *Newfoundland and Labrador Hydro v. Newfoundland and Labrador (Board of Commissioners of Public Utilities)*, 2012 NLCA 38, p. 4

<sup>171</sup> *Ibid*, p. 17

<sup>172</sup> *EPCA*, Section 4.

<sup>173</sup> *Newfoundland and Labrador Hydro v. Newfoundland and Labrador (Board of Commissioners of Public Utilities)*, 2012 NLCA 38, para 27.

The Court concluded:

“the Board has jurisdiction to deal with and dispose of remaining amounts in the RSP in accordance with the broad powers contained in the legislation, which include, but are not limited to, refunding it to the Industrial Customers. But these powers are not necessarily confined to disposing of the RSP fund balances solely to the benefit of one class of customers, in this case the Industrial Customers. This is not to say, of course, that the Board should include customers other than the Industrial Customers as beneficiaries, only that the board has the jurisdiction and authority to, and should, consider the submissions of all interested parties on this issue, taking into account generally accepted sound public utility practice and the imperative of setting, just and reasonable rates that are non-discriminatory. (underlining in original)<sup>174</sup>

The Court ultimately found that the PUB erred in:

1. Allowing its determination of its jurisdiction to be arbitrarily limited by the manner in which the issue was brought before it; procedure cannot trump jurisdictional substance;
2. Not concluding, in accordance with *Bell Canada 1989*, that, in respect of interim orders, all aspects of rates, including RSP rules, were made interim and therefore inherently subject to subsequent review and possible modification, on an application to make interim rates final; and
3. Concluding that the *PUB Act*, properly interpreted, restricted the manner in which deferral accounts could be dealt with and in particular, restricted the classes of beneficiaries of such accounts.”<sup>175</sup>

Having a decision remanded by the Courts is significant, particularly where the Court suggests that the PUB took too narrow a perspective in interpreting its mandate.

In April 2014, the Consumer Advocate appealed a subsequent PUB decision to share a portion of the RSP balance with all Newfoundland and Labrador customers when only Newfoundland customers paid rates that reflected the RSP. In this case, the PUB was following direction provided by government in an Order in Council, which it interpreted narrowly.

The Order in Council stated “Newfoundland and Labrador Hydro’s General Rate Application process shall include a Rate Stabilization Plan surplus refund plan to ratepayers”, except those specifically excluded – the Island Industrial customers. In the proceeding before the PUB regarding the allocation of this refund, NLH and the Consumer Advocate argued that only customers on the IIS should receive the refund since these were the only customers who had paid into the RSP. In its decision (Order No. P.U. 9 (2014)), the PUB took the position that the wording of the Order in Council referred to Newfoundland Power’s ratepayers and NLH’s ratepayers, which meant all NLH’s customers, not just those on the IIS. Thus, the PUB decision directed there be a refund from the RSP to customers on the Island and in Labrador who had never paid into the RSP.

---

<sup>174</sup> Ibid, Para 157.

<sup>175</sup> Ibid, Para 156.

Ultimately, the Court found that “the PUB did not consider whether the purpose of establishing a plan for refunds from the RSP necessarily limits the range of ratepayers who will receive a rebate to those who have paid into the RSP.... and, thus, its decision was unreasonable.”<sup>176</sup> In support of its ruling, the Court noted that “while a ratepayer can receive a rebate of an amount paid for power, can they receive a refund from the RSP when they have never paid into it? It was unreasonable for the PUB to interpret “ratepayers” without having regard to the issue of whether the range of such persons was limited by the purpose set out in the Order in Council of providing a refund from the RSP.”<sup>177</sup>

Having a court overturn a decision by the PUB after another decision was remanded to the PUB and where in that decision the Court found that the PUB had the requisite powers, clearly calls into question whether the PUB’s decisions can be viewed as being predictable and providing certainty.

Finally, a number of industry participants commented that the PUB’s review of NLH’s supplementary capital budget applications for a new 230 kV transmission line from Bay d’Espoir to Western Avalon and a 123.5 MW combustion turbine at Holyrood was conducted efficiently. However, with the combustion turbine needed for the 2014-15 winter peak period, the PUB didn’t finalize cost recovery for the investment. It indicated that this would be subject to a prudence review after the facility was installed.

In sum, there are clearly issues with respect to the relationship between NLH, the PUB and government. As discussed further below, as a regulated electric utility NLH needs to give greater attention to the regulatory function within the company. Under the *EPCA* and *PUA*, the PUB has broad powers to provide the required regulatory oversight. With significant government participation in the electricity sector, in some instances (as evidenced by the appeals of various RSP decisions) the PUB appears to have been reluctant to exercise this discretion. Experience across Canada indicates that the regulator needs to be able act and operate independently, but this requires that government and stakeholders have confidence in the regulator. This confidence will be enhanced when the knowledge and expertise of the PUB is accepted, making it critical that the PUB attract and retain a qualified staff with deep industry knowledge.

## **5.2 Assessment of Consumer Advocate**

As discussed, in Newfoundland and Labrador there is no formal office of Consumer Advocate as in Alberta. The Consumer Advocate is appointed for one-year terms. This approach is effective and efficient where the workload is variable and having a staff position isn’t cost-effective. A review of Table 9 indicates that this has been the case for the five-year period from 2010 to 2014, with hearing expenses for the Consumer Advocate varying from \$281,689 to \$860,976 per year. Interestingly, the Consumer Advocate’s hearing expense varies from less than one-third that of the PUB to 20% more than the PUB during this period. However, if NLH is to be subjected to more regular regulatory oversight which requires additional resources, then a more formal Consumer

---

<sup>176</sup>*The Consumer Advocate v. The Board of Commissioners of Public Utilities*, 2015 NLCA 24, Para 42.

<sup>177</sup> *Ibid*, Para 41.



Advocate function may become appropriate. The consultant structure can prevent the development of institutional knowledge. However, we note that the consultants that support the Consumer Advocate have done so for a considerable period of time, allowing them to possess that institutional knowledge. Consultants can offer broader experience and if the consultant’s performance is unsatisfactory another consultant can be engaged for the next proceeding.

**Table 9: PUB and Consumer Advocate Annual Hearings Expense**

	2014	2013	2012	2011	2010
<b>Board</b>	\$ 1,140,741	\$ 714,955	\$ 1,813,549	\$ 465,146	\$ 508,801
<b>Consumer Advocate</b>	\$ 307,410	\$ 860,976	\$ 692,538	\$ 281,689	\$ 529,450

Source: PUB 2013-2014 Annual Report

The presence of the Consumer Advocate in a relatively small jurisdiction such as Newfoundland and Labrador is a best practice. Furthermore, it appears that the Consumer Advocate plays an important role before the PUB and has effectively represented domestic and general service customers’ interests before the Newfoundland and Labrador Supreme Court, Court of Appeals. See discussion in Section 5.1.

As discussed, the Consumer Advocate’s costs are recovered from the PUB who in turn allocates them to the specific utility in whose application the Consumer Advocate has intervened. This is reasonable and common practice. However, it isn’t clear that there are sufficient protections to ensure that the effort expended by consultants represents an efficient use of resources. In other jurisdictions interveners are required to develop budgets based on the assumed scope of proceedings and to justify fees which exceed this budget estimate.<sup>178</sup> More significant is the fact that all interveners are able to recover their costs from the utility in whose proceeding they intervene. While this is appropriate for domestic and general service customers who cannot be expected to independently band together to fund an intervention that addresses their interests, it is less so for industrial customers who are better able to assess whether an intervention is likely to be cost-effective. For this reason, in Alberta industrial interveners are often responsible for covering their own intervention costs under the test used by the Commission to determine eligibility for cost recovery. Specifically, the Alberta Utilities Commission rules provide: “the Commission may award costs to an intervener who has, or represents a group of utility customers that have, a substantial interest in the subject matter of a hearing or other proceeding and who does not have the means to raise sufficient financial resources to enable the intervener to present its interest adequately in the hearing or other proceeding.”<sup>179</sup> This is a policy that the PUB may wish to consider when determining intervener funding for interventions.

<sup>178</sup> Recognizing that the scope of discovery requests and hearing support cannot be controlled, fees for support in these tasks is often on a time and materials basis.

<sup>179</sup> [http://www.auc.ab.ca/rule-development/intervener-costs/Documents/September%2030%202008/Rule\\_022\\_Sept\\_30\\_08.pdf](http://www.auc.ab.ca/rule-development/intervener-costs/Documents/September%2030%202008/Rule_022_Sept_30_08.pdf), Section 3(1) Cost Eligibility

Some parties have suggested that a possible issue to be considered is that the appointment structure for the Consumer Advocate can result in possible conflicts of interest with respect to providing oversight over NLH. Specifically, with NLH as a Crown utility, and the Consumer Advocate appointed by the Lieutenant Governor, there is some risk that the Consumer Advocate will be less aggressive in overseeing NLH than NP. Having a longer appointment terms for the Consumer Advocate could reduce that risk.

## **6. Governance and Regulatory Best Practices**

This section of the report draws upon the best practices that were identified as part of the jurisdictional review and the team’s professional experience. Best practices can vary with industry structure and objectives. In the simplest terms, best practices for a regulated electricity sector are distinctly different than for a restructured one.

Furthermore, the employment of best practices does not always ensure favorable outcomes. Specifically, some of the best practices identified in different jurisdictions didn’t result in the various entities achieving desired outcomes given that having best practices for one specific area doesn’t necessarily ensure favourable outcomes.

Best practices are presented for four distinct areas: (1) governance; (2) regulatory oversight; (3) commercial issues regarding the integration of major hydroelectric facilities; and (4) electricity sector institutions.

### **6.1 Governance**

As discussed, one resource that was relied upon for this governance review was a report, *Guidelines for the Governance of the Electricity Sector in Canada*, which outlines governance best practices in the electricity sector. This report was the product of a conference held in Toronto in 2010 titled “Governance and Regulation in the Electricity Sector: Balancing Independence with Accountability”. The intent of the conference was to identify opportunities to improve governance of crown corporations and regulatory agencies related to the electricity industry and as such it represents a useful resource regarding best practices. The report was authored by Professor Guy Holburn (Richard Ivey School of Business) in January 2011.

A major difference between Newfoundland and Labrador’s electricity sector and that assumed in this report is that Newfoundland and Labrador has elected to pursue public ownership for major electricity sector investments in the province outside of Newfoundland Power’s distribution footprint. This is reflected in Section 14.1 of the *EPCA*, which provides NLH an exclusive right to supply, transmit, distribute and sell electricity in the province, other than generation facilities owned by a retailer or industrial customer if these facilities existed on December 31, 2011. Therefore, a number of the recommendations in this report are directed at ensuring a level playing field between private and public sector entities and don’t apply. Those elements that do are brought forward below.

From this report and practice elsewhere there are a number of best practices which are reviewed further in this section: (1) articulate clearly Government objectives for the Crown corporation; (2) attract directors with desired skills and experience; (3) develop the knowledge and understanding of Board members; and (4) have independent appointment process for Board and CEO.

### 6.1.1 Clearly Articulate Government Objectives for the Crown Corporation

As shareholder, government clearly has a central role in influencing the direction of Crown utilities. This was evident across all of the jurisdictions evaluated. However, the relationship between the shareholder and the Crown varied. A best practice which was employed in both BC and Ontario was the clear articulation of the Crown corporation's accountabilities to the Crown and the shareholder's responsibilities.<sup>180</sup> In BC this is reflected in a Shareholder Letter of Expectations that outlines BC Hydro's accountabilities, which include service plans that outline specific performance measures and targets for those measures, and the government's responsibilities. The Shareholder Letter of Expectation is updated biannually. In Ontario, both Hydro One Networks and Ontario Power Generation have Memorandums of Agreement (MOA) which outline the agreement of the shareholder and the respective utility under its mandate, governance, performance, and communications.<sup>181</sup> The MOAs also call for performance targets and investment plans which will be submitted to the shareholder for concurrence. Hydro One identifies and assesses its achievement of its performance targets in its Annual Report.

The formal articulation of Government's objectives for Nalcor and NLH can be found in the "strategic directions" reflected in the *Energy Plan*.<sup>182</sup> While the *Energy Plan* was issued about

## Strategic Directions

The strategic directions of the Provincial Government in relation to the energy sector as communicated by the Minister of Natural Resources include:

- **Increased exploration and development of mining and energy resources**
  - Acquisition and promotion of geoscience data
  - Enhanced marketing and promotion of our natural resources
  - Competitive regulatory and policy structures that support resource development
  - Increased exploration and development activity
- **Responsible resource development**
  - Development of clean, renewable energy through the Lower Churchill Project
  - Activities to support Social License through adequate stakeholder consultation
  - Resource developments built on a culture of worker safety and environmental sustainability
  - Integration of advanced technological solutions that reduce environmental impacts
- **Maximum benefits to the province through the strategic development of our resources**
  - Increased participation in energy resource developments
  - Supporting increased local industrial and employment benefits
  - Increased participation of women and underrepresented groups in natural resource projects
- **Stable and competitive energy supply for domestic use and export to market**
  - Alternative energy research and development
  - Advancement of renewable energy projects and related infrastructure
  - Development of industrial electricity rates that support resource development
  - Export of surplus energy
  - Development of innovative technology solutions for existing and new energy sources

<sup>180</sup> This is also captured in the *Guidelines for the Governance of the Electricity Sector in Canada* report.

<sup>181</sup> These MOAs were established in 2005 and have not been updated.

<sup>182</sup> Nalcor and NLH's Strategic Plan specifies that "a strategic direction is the articulation of a desired physical, social, or economic outcome that would normally require action by, or involvement of, more than one government entity." (Strategic Plan 2014-2016, Transparency and Accountability, March 2014, p. 1)

eight years ago and there have been fundamental changes to the province's electricity sector since it was issued (many of which were derived from the *Energy Plan*), these strategic directions appear to continue to be appropriate and represent a reasonable articulation of Government objectives. However, government is better able to assess the appropriateness of these strategic directions in light of its current objectives for the electricity sector. (The sidebar on the previous page identifies these strategic directions.) Nonetheless, it is best practice for such strategic directions to be periodically reassessed, particularly after fundamental changes in industry conditions. Best practices on goals and objectives setting varies depending on the level of attention that the area of focus has received. If it is a fundamental element of government policy that has received significant debate and attention by stakeholders, then a case can be made that these objectives are a natural product of this debate and should be consistent with the view that prevailed. Where this is an area that has received less attention, it is appropriate to ensure that all stakeholder views are heard and considered in the formulation of these objectives and that appropriate effort is devoted to ensuring that they are adequately informed.

While these “strategic directions” appear to be reasonable and represent a reasonable articulation of government policy, it appears that they could be sharpened. For example, one strategic direction is “export of surplus energy”. No direction is provided regarding the value received or risks borne. Providing such strategic direction is best practice. Further definition of this strategic direction would assist Nalcor and NLH in developing the strategic initiatives that properly balance Government objectives.

Finally, Power Advisory reviewed Nalcor and NLH's Strategic Plan (2014-2016) to assess the degree to which the companies' plans appropriately reflect these strategic directions. These strategic directions are the foundation for the Strategic Plan and as such guide the initiatives that flow from it. Furthermore, the *Transparency and Accountability Act* requires that NLH develop a multi-year strategy, business and activity plans and to annually report on their activities and accomplishments relative to these to the Minister of Natural Resources. This allows Government to ensure that NLH's strategic direction and business activities are aligned with Government and if not, Government is aware of this.

On a side note, Power Advisory found that the working relationship between Government and NLH to be effective as evidenced by frequent communication and a good understanding of issues and the other party's perspective. This is critical to a properly functioning electricity sector.

### **6.1.2 Attract Directors with Desired Skills and Experience**

Boards of directors have a critical role to play overseeing the operations of corporations. For boards to perform this role effectively they require appropriate skills and experience to be able to effectively oversee the conduct of business, supervise management and work to ensure that all major issues affecting the business are given proper consideration. To perform these duties effectively, board members must have the requisite skills and expertise.

New Brunswick's amended *Electricity Act* stipulates that the process for nominating directors shall be "a merit-based and objective approach, ensure that the board of directors as a whole has the necessary skills and qualifications to carry out its functions, and provide to the Lieutenant-Governor in Council a description of the recruitment, assessment and selection processes used and the results of those processes".<sup>183</sup> As implemented, the process involves the use of an independent search firm to recruit board members through a competitive process, helping the company to build a roster of new board members with varied skills and experience to assist in providing leadership in the governance and strategic direction of the company. This is a best practice.

This requires that there be a rigorous process for recruiting and selecting directors. This is particularly important in a small jurisdiction such as Newfoundland and Labrador, which limits the opportunities for identifying directors with directly transferable skills.

BC appears to employ best practices for the development of its Boards for Crown agencies. Reflecting the province's well developed governance framework for its various Crown corporations,<sup>184</sup> BC Hydro directors have a Board Governance Manual and a formal Terms of Reference which outlines the Province's expectations for board members.

### **6.1.3 Develop the Knowledge and Understanding of Board Members**

In addition to having the requisite skills and expertise, it is important to recognize that the electricity sector is relatively arcane and therefore these directors should have available to them adequate resources to enhance their understanding of the sector. BC Hydro has formal briefings led by members of the management team and provides site visits. Topics for briefings can include the history of the company, major assets, an overview of regulation, strategic direction, and corporate governance issues. In addition, BC Hydro provides ongoing development opportunities for directors on issues that are of strategic importance to the company.

NLH has an orientation process for Board members when they first become a Board member. The orientation "covers a wide range of topics relevant to the mandate and role of a Board member and includes specific sections and documents related to the provincial statutes noted above; the mandate of the Board of Directors; Hydro's Core Values and its Code of Business Conduct and Ethics; and a comprehensive overview of Best Practices in Corporate Governance prepared by the Company's external legal counsel."<sup>185</sup>

One additional tool that BC Hydro makes available to its directors is an outline of the performance evaluation process for the Chief Executive Officer (CEO) to be employed by the Board. Not surprisingly, the starting point for this process is a statement of goals or primary objectives for the year under review, with these goals and objectives developed by the CEO and approved by the

---

<sup>183</sup> Section 15(7).

<sup>184</sup> This is evidenced by BC's "Best Practice Guidelines on Governance and Disclosure" for public sector organizations, which was issued by the provincial government in February 2005.

<sup>185</sup> NLH 2013 GRA, PUB-NLH-315.

Board. This process also includes a self-evaluation performed by the CEO. These are best practices.

NLH's President and CEO's performance is evaluated by the Board in terms of NLH's performance relative to its goals and the specific metrics identified in its corporate plan, with short-term incentive compensation tied to the achievement of these targets.

#### **6.1.4 Have Independent Appointment Process for NLH Board and CEO**

Under the *Hydro Corporation Act*, Board members sit at the pleasure of the government.<sup>186</sup> *Guidelines for the Governance of the Electricity Sector in Canada* recommends that Board members be appointed for fixed five-year terms to enhance their independence.

The *Hydro Corporation Act* also provides that the CEO of NLH be appointed by the Lieutenant Governor. While currently, the CEO of Nalcor is the CEO of NLH and the CEO of Nalcor is appointed by the Lieutenant Governor, this conflicts with the best practice outlined in the *Guidelines for the Governance of the Electricity Sector in Canada*, which recommended that the CEO should be appointed by the Board. However, this is common across Canada.

### **6.2 Regulatory Oversight**

There are distinct challenges associated with regulating Crown utilities. Providing regulatory oversight over a Crown utility involves three separate relationships between: (1) the Crown utility and the regulator; (2) the government and the regulator; and (3) the Crown utility and its shareholder, the government. While the government has presumably accepted that regulatory oversight will provide the best outcomes, government policy objectives, which change with the government and the specific issues of the day, will not necessarily be embraced by the regulator, who is typically focused more on balancing the interests of customers “in the lowest possible cost consistent with reliable service” with the utility objective of providing “sufficient revenue to ... enable it to earn a just and reasonable return”. This potential conflict is evident across Canada wherever there is a meaningful role for the regulator in overseeing the Crown utility. This conflict poses problems for utility management who must balance the interests of its shareholder and the requirements of the regulator. While investor-owned utilities can be viewed as having a similar balancing act, their shareholder objectives are more immutable and straightforward (realizing a reasonable return given the risks borne) and utility management recognizes the tension between shareholder and regulator objectives. Where there is a Crown utility, management can elect to venue shop (i.e., seek a more favourable deal from the shareholder) and have the government use its directive powers to guide the regulator or exempt the Crown utility from regulatory oversight. This can be in the form of exempting specific facilities from need or certificate of public convenience and necessity reviews.<sup>187</sup> This can also take the form of the shareholder seeking specific rate

---

<sup>186</sup> See Section 6 (2) of the *Hydro Corporation Act* and Section 7 (3) of the *Energy Corporation Act*.

<sup>187</sup> As discussed further below in this section, in some instances exempting such facilities from regulatory review may be appropriate given the broad benefits offered, which are beyond the regulator's traditional purview.

outcomes (i.e., lower rates) that will yield a lower return than the regulator may provide. While this isn't typical, having such an alternative can reduce management's focus and attention to the regulatory function and reduce its effectiveness.

Where the Crown utility is corporatized and operates on a fully commercial basis, tensions in the regulatory relationship between the Crown utility and the regulator are less typical. However, the transition to a commercially oriented electric utility from a Crown-utility that is more imbued with the public interest can result in greater conflict as new roles are established.

Conflicts that arise from this situation can undermine public confidence in the regulatory process and lead stakeholders to question capital investments which were exempted from established regulatory practice. This can also be a barrier to regulatory efficiency and reasonable regulatory outcomes, increasing the effective cost of regulation and causing Crown utilities to seek to further exempt themselves from regulatory oversight.

There are a number of best practices pertaining to regulatory oversight including: (1) employing a public interest test; (2) employing outcome-based policy direction; (3) utilizing the regulatory process to review the need and cost-effectiveness of new resource options; (4) providing oversight over resource planning (5) employing a capital budget review process; (6) ensuring appropriate attention given to the rate regulation function; (7) ensuring appropriate balance to the Rural Subsidy; and (8) ensuring timely rate review processes.

### **6.2.1 Employing a Public Interest Test**

It is the prerogative of governments to set energy policies and then direct regulators to implement these policies. This is done through legislation, regulations, directions, and directives.<sup>188</sup> These can be appropriate tools for communicating public policy objectives that don't conform to the regulator's mandate.

Regulators generally set rates and review proposed projects using a "public interest" test. In a number of jurisdictions "public interest" is identified as a specific regulatory criterion, but not in Newfoundland and Labrador. NLH indicated that in one proceeding an issue arose regarding the sulphur content of the residual oil burned at Holyrood. The lack of a formal "public interest" test in the *PUA* was viewed by the PUB as constraining its ability to approve NLH's plan to use a lower sulphur content fuel at Holyrood given that it was otherwise focused on the "lowest possible cost consistent with reliable service." The Government ultimately issued a directive regarding the use of a lower sulphur fuel at Holyrood.

With respect to how and to what degree should the "public interest" be defined for the PUB, there are two traditional approaches. The first is to legislatively define the "public interest", with the

---

<sup>188</sup> As discussed, the *EPCA* specifically provides for this direction. Section 5.1(1) provides that the Lieutenant-Governor "may direct the public utilities board with respect to the policies and procedures to be implemented by the board with respect to the determination of rate structures of public utilities under the Public Utilities Act and, without limiting the generality of the forgoing..."



degree of definition depending on the confidence that the government has with providing a measure of policy freedom to the regulator. Power Advisory notes that recent decisions by the PUB which indicate a limited willingness to exercise discretion suggest that greater direction may not be utilized under the current composition of the PUB. The second approach is more appropriate for major investment or regulatory policy decisions that require a broader scope and therefore require specific direction for government on how the public interest should be defined and measured. An obvious example is a major hydroelectric project where it is appropriate to consider broader benefits offered by such a project.

The appropriate standard that is to be employed by the PUB to guide its decision-making is a public policy question best determined by government. However, the degree to which the PUB departs from a narrowly defined public interest test expressed in terms of “least cost”, the greater the likelihood that higher costs will be incurred.

Traditionally this public interest test has been narrowly defined for rate matters in terms of “just and reasonable rates” or rates that are “not unduly discriminatory”. The Alberta *Energy and Utilities Board Act* is perhaps the most descriptive in defining the public interest for facility reviews as considering the “economic effects of the development, plant, line or pipeline and the effects of the development, plant, line or pipeline on the environment.”<sup>189</sup>

### **6.2.2 Employing Outcome-Based Policy Direction**

In many jurisdictions governments use public utilities as vehicles for promoting public policy objectives in addition to providing electricity at the “lowest possible cost consistent with reliable service”. It is the government’s prerogative to use the Crown corporation as a vehicle for achieving public interest objectives, but doing so often results in tension between government objectives of promoting specific outcomes and allowing the regulator to operate independently.

To achieve its policy goals, governments can take two general approaches: prescriptive and outcome- based. An example of the prescriptive approach is the Feed-In Tariff program in Ontario, in which the Ontario government directed the Ontario Power Authority to procure renewable generation of various types in a specific way at specific prices, with the Ministry of Energy closely involved in all the details. Examples of an outcome-based approach are Renewable Portfolio Standards widely used by many U.S. states which sets the amount of renewable energy to be procured as a percentage of electricity consumption, but leaves it up to the market how to meet these targets most efficiently. As an even more hands-off approach, governments can put economic incentives in place, such as carbon pricing mechanisms, to encourage utilities (and others) in certain directions. The two approaches are not mutually exclusive; Ontario’s Feed-In Tariff program, for example, is very prescriptive in many ways, but also contains incentives such as priority points and price adders to favour aboriginal and community-based projects.

---

<sup>189</sup> Section 17(1)

A prescriptive approach guarantees that the government’s specific objective will be achieved, but not necessarily in the most cost-effective way. An outcome-based approach provides more flexibility, which can be both more cost-effective and better at managing risk. George Vegh, a lawyer specializing in the energy sector, has noted that many factors affecting electricity systems are unpredictable, including future demand, fuel supply costs and generation technologies, and that “there are strong technical and social arguments in favour of a more flexible approach.”<sup>190</sup>

Best practice from a regulatory efficiency and outcome perspective is for government to delineate policies to the Crown utility and the regulator clearly, and in advance of the specific regulatory proceeding, then leave them to act independently within their mandates. As discussed below, there may be situations where the government does wish to retain the final decision in a matter to itself,<sup>191</sup> and/or there are complex issues within the expertise of the regulator that should be reviewed; in these cases the government could consider referring the matter to the regulator for a recommendation only.

### **6.2.3 Utilizing the Regulatory Process to Review the Need and Cost-Effectiveness of New Resource Options**

As discussed since the mid-1990s major supply additions have typically been exempted from PUB oversight under various directives.<sup>192</sup> These exemptions can be viewed as preventing the PUB from exercising the appropriate degree of regulatory oversight, since under these exemptions the PUB has no ability to evaluate the need for the facility or its cost-effectiveness relative to other alternatives. As discussed, the use of these exemptions is common across Canada. Nonetheless, they do undercut public confidence in the regulatory process and in the reasonableness of government’s decision that the facilities are needed and should be exempted from regulatory review. While best practice is to rely on the regulatory process to assess the need for most facilities and their cost-effectiveness relative to alternatives, for “heritage assets” a different approach is often appropriate.

Specifically, for such facilities it may be appropriate for government to retain the final decision to itself, rather than defer decision-making to the regulator. This is often the case with respect to oversight of major capital projects such as large new remote hydro developments (e.g., Muskrat Falls, Site C in BC, Keeyask and Conawapa in Manitoba). With the review and scope based on classic economic regulation (e.g., does the proposed project represent the least cost alternative for addressing the identified need), regulators are more likely to decide against projects. A case can be made that these types of projects require a broader scope for the public interest that recognizes their strategic significance to the province. The decisions have far reaching affects with implications far

---

<sup>190</sup> George Vegh, Energy Planning, *The Case for a Less Prescriptive Approach*, McCarthy Tetrault, Sep. 23, 2013, p. 2 ([http://www.mccarthy.ca/pubs/George\\_Vegh\\_Sept23\\_2013.pdf](http://www.mccarthy.ca/pubs/George_Vegh_Sept23_2013.pdf)).

<sup>191</sup> This was done in Manitoba in the Needs for Alternatives To proceeding. See Section 2.4.

<sup>192</sup> See for example, *Granite Canal Hydroelectric Project Exemption Order* (O.C. 2000-169/170), *The Newfoundland and Labrador Hydro-Corner Brook Pulp and Paper Limited Exemption Order* (O.C. 2000-489/490), and *Muskrat Falls Exemption Order* (O.C. 2013-342)

broader than lowest cost electricity supply. Therefore, these are legitimate decisions for governments to make and it is appropriate for Government to exempt such projects from formal regulatory review. Another way of looking at such projects is that their economics require looking at benefits beyond the electricity sector and with discount rates that are low, i.e., social discount rates rather than the commercial discount rates in the comfort and expertise zone of regulators.

One way to square the circle of fitting independent regulation with government direction is to involve the regulator with scope appropriate to its skills and purview. For example, regulators typically have much better stakeholder engagement processes than governments and do a better job documenting decisions. Therefore, one possible outcome would be to charge the regulator with making recommendations to government who would have final authority for making decisions. This may be most appropriate for those areas over which governments may wish to retain a high degree of oversight, e.g. over certain functions such as final approval of major infrastructure projects, as discussed further below. For example, for approvals of major pipeline projects the NEB provides recommendations to Cabinet and Cabinet accepts or rejects the NEB's recommendations. As well, regulators are generally better positioned to address detailed economic decisions such as designing how costs get put into customer rates (e.g., back-end loading, ramping up over time using deferral accounts etc.). Such an arrangement between government and regulator avoids both the conflict and the potential loss of public confidence.

Bottom line, regulators work best when their mandate reflects their strengths - due process and economic decision making. Government involvement is best when confined to where independent agencies cannot handle the situation - broad societal strategic interests that don't pigeon hole well.

As discussed, the role of the regulator can be just to make a recommendation to government with government to have final authority (i.e., the approach employed by the NEB for gas pipelines). Furthermore, it is common for a special process to be established for "Heritage Assets" (e.g., Muskrat Falls and the associated transmission investments), which are long-lived resource decisions which are more likely to have benefits that are broader in scope than typically considered by regulators.

#### **6.2.4 Providing Oversight over Resource Planning**

BC Hydro has a rigorous resource planning process, which has been overseen by the BCUC. NB Power is required to file its integrated resource plan (IRP) with the Energy and Utilities Board, which doesn't approve the IRP, but uses it as a point of reference for other decisions. Nova Scotia Power regularly files an IRP with its regulator.<sup>193</sup> Hydro-Québec Distribution files a supply plan with its regulator every three years, which must be approved. SaskPower has no requirement for an

---

<sup>193</sup> Integrated resource planning processes vary from jurisdiction to jurisdiction. However, IRP typically involves developing a long-term forecast of future requirements and assessing the full range of resources that are available to satisfy these requirements including demand-side management and energy efficiency programs and conventional and renewable supply resources and based on this assessment determining the resource portfolio that has the preferred performance characteristics, considering risks, costs and often environmental performance.

IRP to be filed with government or the Rate Review Panel. However, the Panel requested that SaskPower “develop a public dialogue to further educate customers and key stakeholders on the need for Capital Projects, and to provide more transparency on its current plans...”<sup>194</sup> An IRP process provides a strong foundation for such a dialogue.

The PUB clearly has authority to oversee NLH’s resource planning process and to mandate that it file an IRP with the PUB, but has elected not to do so. To some degree the investment in Muskrat Falls and the associated transmission facilities represents the province’s major resource planning decision for the next several years, further obviating a need for such a process. On the other hand, experience elsewhere indicates that consultative resource planning processes enhance public confidence in investment decisions and aligns stakeholder views. One possibility would be to expand the scope of the PUB’s capital budgeting process to encompass integrated resource planning.

Integrated resource planning isn’t typically performed in competitive markets and the scope of IRP is typically more limited where new supply additions are satisfied through a competitive procurement process. However, where a competitive procurement process is utilized prospective participants need information on system requirements to help craft proposals. A resource plan can provide such information.

In sum, best practices vis-à-vis regulatory oversight of utility resource planning decisions depends on the industry structure. Where new supply investments are not underwritten by ratepayers, there is no role for regulatory oversight of such investments. However, requiring that the entity responsible for supplying customers file with the regulator its evaluation of future resource requirements would be appropriate.

### **6.2.5 Employing a Capital Budget Review Process**

There are a wide range of practices in Canada regarding regulatory oversight of capital budgets. For example, the Manitoba Public Utilities Board doesn’t regulate capital expenditures by Manitoba Hydro.<sup>195</sup> Regulating rates without authority to disallow capital spending is not uncommon when regulating Crown utilities. However, for an electric utility such as NLH, which is largely hydroelectric, not having oversight over capital expenditures would significantly constrain the regulator’s ability to effectively oversee rates. As discussed, the PUB has a \$50,000 threshold specified by the *PUA* and embodied in the Capital Budget Filing Guidelines (Guidelines) above which all capital expenditures must be approved. The *EPCA* and Guidelines also have a \$5,000 threshold for approving all capital leases. The PUB considered changes to the Guidelines, which included increasing the \$50,000 and \$5,000 thresholds, which are well below any such thresholds employed by regulators in other jurisdictions.<sup>196</sup> The next lowest threshold that we found was

---

<sup>194</sup> News Release, April 28, 2014

<sup>195</sup> Recall that Manitoba PUB makes recommendations to government regarding Manitoba Hydro’s rates rather than having formal authority to direct Manitoba Hydro regarding its rates.

<sup>196</sup> PUB, 2013-14 Annual Report, p. 11.

\$250,000 which is employed by the Nova Scotia Utility and Review Board. However, we believe that this threshold is relatively low.

The capital budget review process conducted by the PUB and its Capital Budget Filing Guidelines are consistent with best practices. However, the \$50,000 capital expenditure and \$5,000 capital lease threshold are much too low. A capital expenditure threshold of \$5,000,000 is more reasonable.

### **6.2.6 Appropriate Weight and Attention Given to Rate Regulation Function**

NLH is a regulated electric utility, with regulatory oversight provided by the PUB who has responsibility for overseeing rates, reviewing NLH's capital expenditures, and has authority to oversee its resource planning as well, but has not elected to do so. (See discussion in Section 3.2.2.3)

It is typical for electric utilities in Canada to give greater prominence to the regulatory role than NLH has. Newfoundland Power has three Vice Presidents that report to the President, one of which is the Vice President of Regulation & Planning. One of six Senior Vice Presidents (SVPs) report to the President of AltaLink is the SVP of Law & Regulatory & General Counsel.<sup>197</sup> One of five executive level direct reports to the President and CEO of Nova Scotia Power Inc. is the General Manager of Regulatory & Legal Service.<sup>198</sup> One of nine direct reports to the President and CEO of ENMAX Corporation, the electricity utility that serves the city of Calgary and which has a major retail and generation business, is the Executive Vice President of Regulatory & Legal Services.

As Liberty Consulting Group (Liberty) pointed out, "Nalcor's financial organization contains the regulatory affairs function that supports Hydro. It operates under the overall direction of Hydro-based General Manager of Finance. This general manager reports to Nalcor's Chief Financial Officer, who serves Hydro in a similar capacity."<sup>199</sup> Nalcor noted that this general manager has accountability and reports to the Vice President NLH, a member of the executive. NLH indicated that this structure "was implemented shortly after formal sanction of the Muskrat Falls project in December, 2012, and was intended as a transitional structure that ensured a greater executive level focus on the future integration of Muskrat Falls with existing electricity operations from a technical systems operation perspective".<sup>200</sup>

The basic issue is that the regulatory function is embedded within NLH and one area of responsibility for a NLH executive, rather than the primary focus. For other rate regulated entities in Canada, as indicated above the regulatory affairs function typically has greater prominence.

Other than the operations conducted by NLH, Nalcor isn't rate regulated. Nalcor indicates that the regulatory affairs function was moved into NLH to enhance the company's regulatory effectiveness.

---

<sup>197</sup> <http://www.altalink.ca/files/pdf/about/Volume%201%20-%20Application.pdf>, Attachment 1.7B.

<sup>198</sup> <http://oasis.nspower.ca/site/media/oasis/Jan%207%202014%20org%20chart%20with%20SO%20functions.pdf>

<sup>199</sup> Liberty Consulting Group, Review of Supply Plan and Power Outages Island Interconnected System, p. 151.

<sup>200</sup> Response to the Phase I Report by Liberty Consulting, p. 62

NLH clearly has the greatest regulatory requirements of any Nalcor affiliate and as such is a natural home for such capabilities. The regulatory function in NLH doesn't appear to be given the prominence that reflects best practice. Power Advisory believes that this may be one contributor to the issues that NLH has had with respect to regulatory performance (e.g., NLH's 2013 GRA filing). We note that it is common with many other regulated utilities (including those identified earlier) to have an officer responsible for the regulatory function. This ensures that it receives the attention that it deserves within the organization. Liberty also recommended that the regulatory affairs function be escalated to the level of officer.<sup>201</sup> In response NLH acknowledged "that the regulatory affairs function in a regulated utility is a critical one, and that it should have the profile and authority that is appropriate in that context...Hydro's intention is to fully consider Liberty's recommendation as part of Nalcor's determination of its longer-term structure for electricity operations."<sup>202</sup> We also note that NLH made a number of organizational changes after the January 2014 outages to ensure that its organizational structure was well positioned to achieve the Company's reliability objectives.

Furthermore, there is some evidence that the regulatory function within NLH wasn't adequately resourced to respond to the outage inquiry and the GRA. For example, NLH hasn't always been timely with respect to filings and responding to PUB requests.

With the Outage inquiry and no GRA filing since 2007 prior to 2013, it is understandable that NLH may not have had all the resources that it required to conduct the GRA. However, NLH is a rate regulated utility. NP appears to navigate through the regulatory process in the province relatively easily. Its performance is in stark contrast to NLH's in this area, suggesting that devoting the appropriate level of resources and adequate management attention is important to the utility's financial performance.

### **6.2.7 Ensuring Appropriate Balance to the Rural Subsidy**

Customers on the 21 isolated systems in Newfoundland and Labrador and in rural areas in Newfoundland receive a subsidy that is funded by Newfoundland Power and Labrador Interconnected System domestic customers. This subsidy provides these domestic customers with a lifeline block averaging 850 kWh per month at Newfoundland Power retail rates to cover basic needs as well as providing a comparable customer charge as offered by Newfoundland Power. This program also provides electricity at below cost for general service customers and for domestic customers' consumption beyond the lifeline block. The Government's Northern Strategic Plan subsidy also provides an additional subsidy to further reduce lifeline block rates for Labrador domestic customers to the rates paid by Labrador interconnected domestic customers.

This Rural Deficit Subsidy is estimated to be about \$65 million in 2015. This subsidy is paid by domestic and general service customers and represents a significant portion of these customers'

---

<sup>201</sup> Recommendation 10.2

<sup>202</sup> Response to the Phase I Report by Liberty Consulting, p. 63

total costs. NLH estimated that the cost of this subsidy represented about 8% of the 2015 bills of NP customers.<sup>203</sup> More troubling is the fact that the amount of the deficit has increased by over 110% from 1993 to 2013, reflecting in part increased consumption by the customers served under the program.<sup>204</sup> This increase in consumption is attributable in part to the subsidy that they receive and the extension of the lifeline block.

Policies to “levelize” rates for domestic customers are common across Canada. However, most of these policies are focused on addressing differences in distribution costs, not energy supply costs given that the customers that benefit from these programs in other jurisdictions are typically interconnected to the “provincial grid”. The customer rate impacts attributable to the Rural Deficit Subsidy are the largest in Canada. In 2014 Ontario was forecast to collect \$176 million for its Rural Rate Protection program, which reduced distribution cost differences between rural areas served by Hydro One and other distribution companies, but this resulted in about a 1% rate impact to customers funding the program.<sup>205</sup> The greater rate impact for the Rural Subsidy is attributable to the significant disparity in costs for these isolated diesel systems and the interconnected systems and the relatively significant number of customers covered by the subsidy. Power Advisory understands that the subsidy reflects social policy and is an effort to address the disparity between these different populations. However, given the cost impact on those customers providing the subsidy, a case can be made that the subsidy should be for a lifeline block, but that beyond this a price signal should be sent to customers that is more reflective of the high cost of serving them so that they use this energy efficiently and aggressively pursue energy efficiency alternatives.<sup>206</sup>

### **6.2.8 Ensuring Timely Rate Review Processes**

Prior to its July 2013 GRA filing, NLH’s previous GRA was in 2007. As discussed, there were a number of factors that delayed the filing of NLH’s GRA. Power Advisory reviewed a list of these factors prepared by NLH and found it be compelling. Nonetheless, waiting six years between GRA filings cannot be viewed as best practice even with an annual capital budget process, which allows capital additions to be evaluated and approved and a Rate Stabilization Plan that accommodates changes in fuel prices for Holyrood and the impacts of changes of load and hydro output on Holyrood’s fuel requirements. NLH’s experience with its 2013 GRA supports this assessment. In addition, some customers are as concerned with respect to the predictability of rates as actual rate levels and long periods between rate cases increases the risks of significant changes in rates as a result of a GRA. Both NLH and Government have indicated they understand the concerns relating to a lengthy GRA process and expect more regular intervals between GRAs in the future.

---

<sup>203</sup> 2013 NLH General Rate Application, PUB-NLH-081 (Revision 1, Nov 20-14)

<sup>204</sup> Helios Centre, Comments on the 2013 General Rate Application of Newfoundland Labrador Hydro, p. 10

<sup>205</sup> The rural rate protection charge in Ontario averaged about .13 cents per kWh on a typical residential rate of about 13 cents per kWh.

<sup>206</sup> NLH does have energy efficiency programs that are targeted to these isolated customers.

NB Power has a requirement to file for approval of its electricity rates on an annual basis. This is relatively resource intensive. However, the annual requirement is likely to result in efficiencies in the process. Alternatively, there could be a requirement to file a GRA every three years.

A second aspect to the timeliness of the rate review process is that of the regulator in reviewing the GRA. Often the pacing of the review process depends on the applicant. Therefore, requirements that decisions be issued within a fixed period of when the application is filed can be problematic. However, the conduct of the regulator can have a bearing on the pace at which the rate review proceeds. Best practice is to establish an issues list early in the proceeding and to ensure that this issue list is used to guide the scope of the case.<sup>207</sup>

What is more reasonable and common is that there be a requirement that decisions be issued within a set period from when the record is closed. The Alberta Utilities Commission and Ontario Energy PUB seek to issue decisions within 90 days after the record is closed. This is best practice.

### **6.3 Commercial Issues regarding Integrating Major Hydroelectric Facilities**

There are a number of commercial issues associated with the integration of major hydroelectric projects such as Muskrat Falls for which there are best practices that the government may wish to consider as Newfoundland and Labrador's electricity sector transitions to an interconnected system. These issues include: (1) ensuring sufficient resources are devoted to participation in export markets; (2) enabling appropriate transmission access; (3) providing appropriate degree of functional separation of system operator function; and (4) enabling oversight of long-term export contracts.

#### **6.3.1 Ensuring Sufficient Resources are Devoted to Participation in Export Markets**

A best practice is recognizing the importance associated with active participation in various export markets and developing a strategy for doing so that is well suited to the province's resources and objectives. Different Canadian utilities have elected to have different roles in export markets. Manitoba Hydro and Hydro-Québec clearly have pursued fundamentally different strategies vis-à-vis export sales. Manitoba Hydro employs a more conservative approach. For example, it doesn't have market-based rate authority in the US and transacts at the Canada/US Border. Manitoba Hydro elects to do this to avoid US income taxes on its export sales. Manitoba Hydro employs asset-back trading. Specifically, it sells power when it is sure that it has power to sell and deliberately avoids taking positions when there is no physical hedge that could otherwise expose it to trading losses. This reduces the need to take financial positions which expose it to risk. However, this also limits its ability to aggressively pursue profitable sales opportunities. In addition, much of Manitoba Hydro's export transactions are under longer term (e.g., 15 years) sales which provide a fixed price and revenue certainty for Manitoba Hydro. Manitoba Hydro does this to allow it to more efficiently integrate the large hydroelectric projects that it develops and to

---

<sup>207</sup> This issues list may evolve over the course of the proceeding or can be used by the hearings officer or case manager as a general guideline in terms of determining issues that are within or outside the scope of the proceeding.



advance the in-service dates of such projects. Furthermore, given its relatively limited balance sheet and high leverage Manitoba Hydro needs the revenue certainty offered by such long-term contracts.

However, Manitoba Hydro actively participates in various MISO committees and MAPP. For example, with support from Manitoba Hydro, MISO conducted a study evaluating the benefits offered by the development of additional transmission interconnecting Manitoba and MISO markets in the US and the Keeyask Hydroelectric Project in Manitoba.

Hydro-Québec, on the other hand, has market-based rate authority and maintains a strong presence in US electricity markets. H.Q. Energy Services (US), its US-based marketing affiliate, maintains an office in Hartford, Connecticut which is centrally located in New England and as discussed, has staff members that are active on a number of New England electricity and energy organizations, and closely monitors the ISO-NE and NEPOOL committees that have a critical role in establishing the rules that specify how prices are established. This strong presence in the US Northeast energy market has allowed it to successfully support legislation to have large Canadian hydroelectric generation be treated as a renewable energy resource under certain conditions in some Northeast energy markets. In addition, Hydro-Québec is aggressively pursuing the development of a number of transmission projects to increase its access to Northeast electricity markets. This includes the Northern Pass transmission project which it is pursuing jointly with Eversource Energy (formally Northeast Utilities) and would allow it to deliver energy into Southern New Hampshire relatively close to major load centres in New England. Hydro-Québec also appears to be participating in the Champlain Hudson Power Express project which is a merchant transmission line which would allow it to deliver energy to New York City, which is one of the highest priced markets in the US Northeast.

Hydro-Québec's distinctly different approach than Manitoba Hydro vis-à-vis exports reflects: (1) its better access to more diverse electricity markets, which are characterized by higher levels of price volatility; (2) considerably greater storage capability of its reservoirs, which facilitates its ability to opportunistically participate in these markets; and (3) greater financial resources as evidenced by a stronger balance sheet, which allows it to finance these capital intensive new hydroelectric projects using internal resources, without the need for long-term contracts to strengthen its balance sheet.

Nalcor will need to determine what role it will take in these potential export markets. We believe that Hydro-Quebec's active participation from a policy as well as trade perspective in these markets is consistent with best practices. However, Nalcor's approach will need to consider its resource portfolio, energy and capacity available for export, tax considerations, and market access alternatives.

### **6.3.2 Enabling Appropriate Transmission Access**

All Canadian provinces other than Newfoundland and Labrador have implemented Open Access Transmission Tariffs (OATTs). As discussed earlier, these transmission tariffs provide all parties

comparable transmission access as the transmission provider offers to its affiliates and by so doing prevent transmission from being used to unduly restrict market access. Having such a tariff or a tariff that provides a comparable level of service is a best practice and introduced significant efficiencies by increasing trade across North American power markets.

In addition, to transact freely in these US Northeast electricity markets Nalcor affiliates require authority from the US Federal Energy Regulatory Commission (FERC) to sell electricity at market-based rates.<sup>208</sup> In Order No. 679 (Market-Based Rates For Wholesale Sales Of Electric Energy, Capacity And Ancillary Services By Public Utilities) FERC outlines its standards for determining whether electricity sector market participants will be granted authority to sell energy, capacity and ancillary services at market-based rates. To be granted such authority FERC clarified that a seller affiliated with a foreign utility selling in the US must not have, or must have mitigated market power in generation and transmission. Specifically, FERC indicated that it requires a:

“seller affiliated with a foreign utility seeking market-based rate authority demonstrate that its transmission-owning affiliate offers non-discriminatory access to its transmission system that can be used by its competitors to reach United States markets. The Commission does not consider transmission and generation facilities that are located exclusively outside of the United States and that are not directly interconnected to the United States. However, the Commission would consider transmission facilities that are exclusively outside the United States but nevertheless interconnected to an affiliate’s transmission system that is directly interconnected to the United States.”<sup>209</sup>

Under this framework, the terms of access for NLH’s transmission facilities would not be considered by FERC when determining whether it or its affiliates should receive market-based rate authority because these facilities are not directly interconnected to the United States. While FERC may not directly require NLH to have an OATT or functionally separate its merchant and transmission/system operation functions to enable Nalcor affiliates to sell electricity at market-based rates in the US, there are other important reasons to meet these requirements, which are discussed below.

Nalcor affiliates take transmission service under various OATTs and the Nova Scotia Power, NB Power and Hydro-Québec TransÉnergie OATTs all have reciprocity provisions which would effectively allow them to preclude access to their transmission systems if they find that NLH’s transmission tariff doesn’t provide comparable transmission service.<sup>210</sup> Specifically, under these

---

<sup>208</sup> The alternative is a cost-based rate, which during some periods would likely limit the prices that Nalcor affiliates would be able to charge based on the overall cost of the project.

<sup>209</sup> p. 574.

<sup>210</sup> While the language in each of these transmission providers’ tariffs varies slightly it is generally similar. The Hydro-Quebec TransÉnergie tariff provides: “A Transmission Customer receiving Transmission Service under the provisions herein agrees to provide comparable Transmission Service to the Generator [Hydro-Quebec Production] and Distributor on similar terms and conditions over facilities used for power transmission in interstate, interprovincial and international commerce, and owned, controlled or operated by the Transmission Customer or by its Affiliates.”

OATTs Nalcor and its affiliates have an obligation to offer an equivalent level of transmission service or risk having transmission service under these OATTs be denied to it. Furthermore, in the Maritime Link – Transmission Service Agreement between Nalcor and Emera imposed a reciprocity obligation on Nalcor and its affiliates which them to offer “comparable transmission service on similar terms and conditions over facilities used for the transmission of Energy in inter-provincial commerce which are owned, controlled or operated by Transmission Customer or Transmission Customer's Affiliates.”<sup>211</sup>

If a Nalcor affiliate wanted to dispute such a finding by these transmission providers there would be a hearing before the relevant provincial energy regulator who typically hears such disputes. Therefore, there is a risk that if NLH’s transmission tariff doesn’t provide clearly comparable service as the pro-forma OATT specified by FERC that these transmission providers will seek to restrict access to NLH and its affiliates under these reciprocity provisions.

As discussed earlier in Section 2.3.3, Nalcor has contracted for 265 MW transmission capacity on the Hydro-Québec TransÉnergie system from Québec to the New York border with the ability to transmit electricity to other markets. This agreement runs for an additional nine years and has a revolving renewal right. Therefore, if NLH fails to implement an OATT patterned after the FERC pro forma tariff, there’s a reasonable risk that Hydro-Québec TransÉnergie would elect to not provide transmission service to the Nalcor affiliate.

Therefore, NLH or a Nalcor affiliate must determine what form of transmission service it will offer once Newfoundland and Labrador is interconnected with the rest of the North American electricity grid. Specifically, it must determine if it will implement a: (1) OATT patterned after the FERC pro forma tariff, which is what has been typically implemented in other Canadian provinces; or (2) transmission tariff which provides virtually comparable level of service, but differs from the FERC pro forma tariff. This second alternative can take a wide range of forms depending on the underlying market structure (e.g., Ontario has financial, not physical transmission rights which are what is reflected in FERC’s OATT).

NLH or a Nalcor affiliate could administer a transmission tariff which is not likely to be viewed as providing a comparable level of service, but this creates the risk that Nalcor affiliates access to export markets will be constrained by the reciprocity provisions in OATTs and that the revenues offered by participation in such markets will be adversely affected. Therefore, this isn’t viewed by Power Advisory as a viable alternative since it could preclude Nalcor’s access to other electricity markets and with the development of the Muskrat Falls project there will be “surplus” energy available for resale after domestic requirements and other contractual commitments (deliveries to Nova Scotia as part of the Maritime Link transaction) are met.<sup>212</sup> The competitive wholesale power markets in the US Northeast are likely to be attractive markets for such sales given their liquidity (i.e., their ability to accept additional quantities of energy without significant price impacts) and

---

<sup>211</sup> Article 3.3 (h)

<sup>212</sup> These are described in the first report at Section 2.4.1.

given the price transparency (visible prices that are known to all market participants). In addition, they represent a valuable pricing reference point for energy sales that Nalcor affiliates may elect to pursue in other markets that don't offer the same price transparency.

The final implementation question that needs to be addressed regardless of the form of transmission tariff implemented is what process will be available for hearing any disputes that may arise from the administration of the tariff. In most Canadian provinces (all except Manitoba and Saskatchewan who doesn't have a formal regulator) disputes are heard by the provincial regulator. This is viewed as Best Practice. The PUB would be the natural party to hear such disputes given that this would be consistent with its existing practice.

### **6.3.3 Providing Appropriate Degree of Functional Separation of System Operator Functions**

As discussed in Chapter 4, there are a wide range of market structures in place across Canada and more broadly in North America. Ontario and Alberta have independent system operators which have responsibility for administering their transmission tariffs, operating the electricity transmission system, determining the amount of available transmission capacity and administering the wholesale power market. New Brunswick had a separate system operator with similar functions, but more limited market-related functions given the form of New Brunswick's electricity market, which was physically, financially, and operationally separate from NB Power, the province's crown-owned utility. However as discussed, the New Brunswick system operator was reintegrated into NB Power in 2013 in an effort to realize operating efficiencies. Nova Scotia's system operator is housed separately from the rest of Nova Scotia Power, but shares the same Board.

Newfoundland and Labrador will need to determine where these system operator functions will reside. The reciprocity provisions in OATTs also apply to the provisions of FERC Order 889, which require functional separation of the transmission functions from the merchant functions. Therefore, if NLH and various Nalcor affiliates are to address these reciprocity provisions the options include: (1) have functions reside within NLH, but with functional separation consistent with the framework outlined by FERC Order 889;<sup>213</sup> or (2) creation of a separate entity to provide these services. The second option is progressively more complicated and costly. Functional separation of these functions at a minimum is best practice where multiple parties will avail themselves of the transmission facilities.

### **6.3.4 Enabling Oversight of Long-term Export Contracts**

Just as it is common for regulators to have authority over the development and construction of major new electric generating projects, in many jurisdictions regulators have authority to approve long-term contracts. The rationale for oversight of long-term export contracts can be compelling because of the potential for the costs and benefits to flow directly outside the province. This is

---

<sup>213</sup> FERC Order 889 clearly doesn't apply to NLH, but it does represent an operating construct that has been widely implemented.

particularly important where the risks associated with such contracts ultimately are borne or shared with ratepayers. However, where these risks reside with the utility (e.g., in Québec where these risks are borne by Hydro-Québec Production and its shareholder) there is no need for the regulator to oversee or approve such contracts. Nonetheless, here as well, government may desire that any oversight regarding such contracts reside with it, as shareholder. Alternatively, a case can be made that the regulator is best positioned to provide such oversight given the resources available to it. However as discussed above, if the risks of these contracts are not borne by ratepayers then regulatory oversight is inappropriate unless government is seeking the regulator's expertise in this area. In this instance, the regulator could be asked to review such investments and make recommendations.

If it is determined that such regulatory or governmental oversight is required then the standards regarding when such contracts should be approved would be required. Essentially, this requires an assessment of the risks and rewards offered by the contract. With regulatory oversight only appropriate where ratepayers are at risk, this risk – reward assessment should be from the perspective of ratepayers and consider the magnitude of the export contract and rate implications from the range of possible outcomes versus those without the proposed contract or alternative contractual terms that are likely to be available. For example, contracts with terms of less than one-year or less than 50 MW could be exempt from oversight.

Neither the *EPCA* nor the *PUA* provide for any regulation of long-term export contracts. Therefore, if government finds that oversight is appropriate, legislative changes will be required.

### **6.3.5 Protecting the Benefits of NLH's Hydroelectric Generation to Customers**

Hydroelectric facilities have unique operating cost and performance characteristics. Similar to many other renewable energy technologies, their operating costs represent a relatively small proportion of the facility's total cost. One additional benefit that they offer is that their useful operating life can approach 100 or more years, with appropriate maintenance and investment. Recognizing these characteristics and the attendant benefits to customers, BC and Québec have opted for heritage pools or contracts, which effectively ring-fence existing hydroelectric facilities and guarantee the benefits of low cost energy from these facilities to customers. In BC this has meant that the cost of these facilities are established on a cost-of-service basis to reflect the underlying cost of providing service to customers. In Québec the Heritage Pool price was fixed for over ten years. However, as the facilities' costs were depreciated and recovered from customers their costs declined such that a fixed price provided greater returns to Hydro-Québec Production. Furthermore, the Heritage Pool was for a fixed volume. The net result is that this structure provided Québec consumers with the benefits of relatively stable wholesale electricity rates and results in the risks and rewards of new facilities being borne by the shareholder, rather than customers.

If Newfoundland and Labrador were to implement a Heritage Pool a number of decisions would need to be made regarding its structure. The two most fundamental are the: (1) assets to be covered; and (2) framework that would be used to establish the Heritage rate over time.

#### **6.3.5.1 *Assets Covered***

For example, this could include one or more of: (1) Muskrat Falls; (2) all NLH hydro facilities; or (3) all NLH facilities (hydro and thermal). The Muskrat Falls Power Contract effectively establishes the terms under which NLH has access to output from Muskrat Falls. This Power Contract was used to finance the project and cannot easily be renegotiated even though the counterparties are both Nalcor affiliates. NLH's thermal facilities don't have cost characteristics that cause them to be well suited to a Heritage Pool. However, if they represented a small portion of the overall required output then they could be incorporated into the pool if consideration was given to varying fuel costs (e.g., through a "tolling arrangement" where fuel costs were passed through to customers). Therefore, the most obvious facilities to be included in the Heritage Pool are NLH's existing hydro facilities. If the Heritage Pool were to cover these facilities an annual volume will need to be established and a representative output profile or ability of NLH to call on energy within specific physical operating (including performance and storage) constraints. Alternatively, the Heritage Pool could be extended to cover NLH's gas turbines given that they may represent a valuable part of NLH's overall generation portfolio and as such can be used to support export trade. If gas turbines are to be included specific provisions will be required to ensure that fuel costs are considered and borne by the appropriate party.

#### **6.3.5.2 *Framework for Establishing Heritage Rate Over Time***

The PUB could be given authority to establish the Heritage rate (e.g., as in BC) or the Heritage rate could be prescribed by Government (e.g., as in Québec). Having the PUB establish the Heritage rate enhances transparency, but can increase administrative complexity. However, with the cost for these facilities largely fixed there is likely to be a limited need for the PUB to review the cost of these facilities in subsequent rate cases. This presumably would require a legislative change to allow NLH to limit regulatory review of its costs of non-Heritage pools assets. Another possibility would be to have the PUB conduct a hearing regarding what the initial Heritage rate should be and government could provide direction regarding the appropriate initial return on capital and the conditions under when the Heritage rate could be re-evaluated.<sup>214</sup>

Alternatively, the Heritage rate can be set by government based on an assessment of what's the appropriate return to be earned and the underlying cost of providing the service.

---

<sup>214</sup> Power Advisory LLC, Incentive Regulation Options for Ontario Power Generation's Prescribed Generation Assets, Ontario Energy Board April 20, 2012

## **6.4 Electricity Sector Institutions**

The jurisdictional review summarized in Chapter 4 indicates the wide range of electricity sector institutions that are evident across Canada. In many instances, the composition and appropriateness of these institutions depends on the model for oversight of the electricity sector (e.g., regulation).

### **6.4.1 Ensuring Appropriate Levels of Investment in Energy Efficiency and Demand Management**

Nova Scotia established Efficiency Nova Scotia in 2010 to create a single purpose entity that was focused on pursuing cost-effective energy efficiency and demand management in Nova Scotia's electricity sector. The scope of Efficiency Nova Scotia's programs were broadened when an agreement with the Province was reached a year later to have it focus on the full range of energy efficiency and conservation alternatives (e.g., oil and natural gas heat and hot water).

In Newfoundland and Labrador electric heat has an 85% penetration rate and electric heating loads drive peak demand in the province. With no natural gas infrastructure, it isn't an available option and at recent price levels, oil didn't offer compelling savings. Residential customer's reliance on electric heat is an important issue. There is some evidence that cold climate ultra-efficient heat pumps are an attractive alternative to baseboard electric heat, offering bill savings of 20 to 30% depending on the home size and building efficiency. These savings are highly dependent on the proper installation of the heat pump and this requires skilled trades across the province.

Interestingly, Nova Scotia, PEI and New Brunswick have seen significant penetration of heat pumps.

In Newfoundland and Labrador similar to Nova Scotia, utilities incentives to aggressively pursue such programs are muted by ratemaking practice, whereby fixed costs are recovered in energy charges such that reductions in load can result in reduced cost recovery and lower net income. Therefore, having an independent organization such as Efficiency Nova Scotia pursue such programs may be beneficial.

## **6.5 Summary of Best Practices**

The best practices identified in this section which are relevant to Newfoundland and Labrador are outlined below. The identification of these best practices should not be viewed as indicating that this is necessarily an area of deficiency in Newfoundland and Labrador, only that these are important issues. Furthermore, for some areas the determination of best practice for Newfoundland and Labrador will be guided by government and stakeholder objectives. In these instances, alternatives are discussed.

### **Clearly Articulate Government Objectives for the Crown Corporation**

The formal articulation of Government's objectives for Nalcor and NLH can be found in the "strategic directions" reflected in the *Energy Plan*. While the Energy Plan was issued about eight years ago, these strategic directions appear to continue to be appropriate and represent a reasonable

articulation of Government objectives. However, government is better able to assess the appropriateness of these strategic directions in light of current objectives for the electricity sector. It is best practice for such strategic directions to be periodically reassessed, particularly after fundamental changes in industry conditions. At a minimum, it appears that they could be sharpened.

### **Attract Directors with Desired Skills and Experience**

To perform their duties effectively board members must have the requisite skills and expertise. Best practice is for board members to be appointed using a merit-based and objective approach, which ensures that the Board as a whole has the necessary skills and qualifications to carry out its functions. This can take the form of using an independent search firm to recruit board members through a competitive process. Providing directors with a formal Terms of Reference which outlines the Province's expectations is also a best practice.

### **Develop the Knowledge and Understanding of Board Members**

Best practice is for directors of boards to have available to them adequate resources to enhance their understanding of the electricity sector. This can include formal briefings led by members of Nalcor's management team on the full range of relevant topics.

Directors play a critical role in the performance evaluation process for the CEO. An appropriate starting point for this process is a statement of goals or primary objectives for the year under review, with these goals and objectives developed by the CEO and approved by the Board. This process should include a self-evaluation performed by the CEO.

### **Appointment Process for Board and CEO**

*Guidelines for the Governance of the Electricity Sector in Canada* recommends that Board members be appointed for fixed five-year terms to enhance their independence and that the CEO should be appointed by the Board.

### **Employ a Public Interest Test**

Regulators need an explicit standard to guide their decision making. What that appropriate standard is, is a public policy question best determined by government. However, the degree to which the PUB departs from a narrowly defined public interest test expressed in terms of "least cost", the greater the likelihood that higher costs will be incurred. Traditionally this public interest test has been narrowly defined for rate matters in terms of "just and reasonable rates" or rates that are "not unduly discriminatory". The *Alberta Energy and Utilities Board Act* is perhaps the most descriptive in defining the public interest for facility reviews as considering the "economic effects of the development, plant, line or pipeline and the effects of the development, plant, line or pipeline on the environment."



## **Employ Outcome-Based Policy Direction**

Best practice from a regulatory efficiency and outcome perspective is for government to delineate policies to the Crown utility and the regulator clearly, and in advance of the specific regulatory proceeding, then leave them to act independently within their mandates.

## **Utilizing the Regulatory Process to Review the Need and Cost-Effectiveness of New Resource Options**

Best practice is to rely on the regulatory process to assess the need for major new facilities and their cost-effectiveness relative to alternatives. However, there may be situations where government wishes to retain the final decision in a matter to itself, rather than defer decision-making to the regulator. This is often the case with respect to oversight of major capital projects such as large new hydro developments. A case can be made that these types of projects require a broader scope for the public interest that recognizes their strategic significance to the province. Therefore, these are legitimate decisions for governments to make and it is appropriate for Government to exempt such projects from formal regulatory review.

## **Providing Oversight over Resource Planning**

Experience elsewhere indicates that consultative resource planning processes enhance public confidence in investment decisions and aligns stakeholder views. However, best practices vis-à-vis regulatory oversight of utility resource planning decisions depends on the industry structure. Where new supply investments are not underwritten by ratepayers, there is no role for regulatory oversight of such investments. However, requiring that entity responsible for supplying customers file with the regulator its evaluation of future resource requirements would be appropriate.

## **Employing a Capital Budget Review Process**

The capital budget review process conducted by the PUB and its Capital Budget Filing Guidelines are consistent with best practices. However, the \$50,000 capital expenditure and \$5,000 capital lease threshold are much too low. A capital expenditure threshold of \$5,000,000 is more reasonable. As discussed above, expanding the scope of the capital budgeting process to more broadly consider resource planning issues may also be appropriate.

## **Appropriate Weight and Attention Given to Rate Regulation Function**

NLH is a regulated electric utility, with regulatory oversight provided by the PUB who has responsibility for overseeing rates, reviewing NLH's capital expenditures, and has authority to oversee its resource planning as well, but has not elected to do so. The regulatory function in NLH doesn't appear to be given the prominence that it deserves. It is common with many other regulated utilities to have an officer responsible for the regulatory function. This ensures that it receives the attention that it deserves within the organization.

## **Ensuring Appropriate Balance to the Rural Deficit Subsidy**

Customers on the 21 isolated systems in Newfoundland and Labrador and in rural areas in Newfoundland receive a subsidy that is funded by Newfoundland Power and Labrador Interconnected System domestic and general service customers. This subsidy provides these rural domestic and general service customers with a lifeline block averaging 850 kWh per month at Newfoundland Power retail rates. NLH estimated that the cost of this subsidy represented about 8% of NP customers' total costs in 2015. Given these cost impacts on these customers, a case can be made that the subsidy should be for a lifeline block, but that beyond this a price signal should be sent to customers that is more reflective of the high cost of serving them so that they use this energy efficiently and aggressively pursue energy efficiency alternatives.

## **Ensuring Timely Rate Review Processes**

Prior to its July 2013 GRA filing, NLH's previous GRA was in 2007. Waiting six years between GRA filings cannot be viewed as best practice even with an annual capital budget process and a Rate Stabilization Plan that accommodates changes in fuel prices for Holyrood and the impacts of changes of load and hydro output on Holyrood's fuel requirements. In addition, industrial customers are as concerned with respect to the predictability of rates as actual rate levels and long periods between rate cases increases the risks of significant changes in rates as a result of a GRA.

A second aspect to the timeliness of the rate review process is that of the regulator in reviewing the GRA. The conduct of the regulator can have a bearing on the pace at which the rate review proceeds. Best practice is to establish an issues list early in the proceeding and to ensure that this issue list is used to guide the scope of the case. It is also relatively common that there be a requirement or a formal goal that decisions be issued within a set period from when the record is closed. The Alberta Utilities Commission and Ontario Energy Board seek to issue decisions within 90 days after the record is closed. This is best practice.

## **Ensuring Sufficient Resources are Devoted to Participation in Export Markets**

A best practice is recognizing the importance associated with active participation in various export markets and developing a strategy for doing so that is well suited to the province's electricity resources and objectives. Hydro-Quebec's active participation in its export markets from a policy as well as trade perspective is consistent with best practices. Nalcor's approach will need to consider its resource portfolio, energy and capacity available for export, tax considerations, and market access alternatives.

## **Enabling Appropriate Transmission Access**

Having an Open Access Transmission Tariff or a tariff that provides a comparable level of service is a best practice. NLH or a Nalcor affiliate must determine what form of transmission service it will offer once Newfoundland and Labrador is interconnected with the rest of the North American electricity grid. Specifically, it must determine if it will implement a: (1) OATT patterned after the

FERC pro forma tariff, which is what has been typically implemented in other Canadian provinces; or (2) transmission tariff which provides virtually comparable level of service, but differs from the FERC pro forma tariff.

The final implementation question that needs to be addressed regardless of the form of transmission tariff implemented is what process will be available for hearing any disputes that may arise from the administration of the tariff. In most Canadian provinces (all except Manitoba and Saskatchewan who doesn't have a formal regulator) disputes are heard by the provincial regulator. This is viewed as best practice.

### **Providing Appropriate Degree of Functional Separation of System Operator Functions**

Newfoundland and Labrador will need to determine where the system operator functions will reside. Options include: (1) have functions reside within NLH, but with functional separation consistent with the framework outlined by FERC Order 889,<sup>215</sup> or (2) creation of a separate entity to provide these services. Clearly, the first option is the easiest and the lowest cost. The second options is more complicated and costly. Functional separation of these functions at a minimum is best practice where multiple parties will avail themselves of the transmission facilities.

### **Enabling Oversight of Long-term Export Contracts**

In many jurisdictions regulators have authority to approve long-term contracts. This is important where the risks associated with such contracts ultimately are borne or shared with ratepayers. Where these risks reside with the utility (e.g., in Québec where these risks are borne by the utility and its shareholder) there is no need for the regulator to oversee or approve such contracts. The rationale for oversight of export contracts is more compelling because the costs and benefits are likely to flow more directly outside the province. Here as well, government may desire that any oversight regarding such contracts reside with it, as shareholder. Alternatively, a case can be made that the regulator is best positioned to provide such oversight given the resources available to it.

If it is determined that such regulatory or governmental oversight is required then standards regarding when such contracts should be approved would be required. Essentially, this requires an assessment of the risks and rewards offered by the contract. With regulatory oversight only appropriate where ratepayers are at risk, this risk – reward assessment should be from the perspective of ratepayers and consider the magnitude of the export contract and rate implications from the range of possible outcomes versus those without the proposed contract or alternative contractual terms that are likely to be available.

---

<sup>215</sup> FERC Order 889 clearly doesn't apply to NLH, but it does represent an operating construct that has been widely implemented.

## **Protecting the Benefits of NLH’s Hydroelectric Generation to Customers**

BC and Québec have opted for heritage pools or contracts to ensure the benefits of low cost energy from their hydroelectric facilities to customers. If Newfoundland and Labrador were to implement a Heritage Pool a number of decisions would need to be made regarding its structure. The two most fundamental are the: (1) assets to be covered; and (2) framework that would be used to establish the Heritage rate over time. The most obvious facilities to be included in the Heritage Pool in Newfoundland and Labrador are NLH’s existing hydro facilities. If the Heritage Pool were to cover these facilities an annual volume will need to be established and a representative output profile or ability of NLH to call on energy within specific physical operating (including performance and storage) constraints.

The PUB could be given authority to establish the Heritage rate (e.g., as in BC) or the Heritage rate could be prescribed by Government (e.g., as in Québec). Having the PUB establish the Heritage rate enhances transparency, but can increase administrative complexity. Another possibility would be to have the PUB conduct a hearing regarding what the initial Heritage rate should be and government could provide direction regarding the appropriate initial return on capital and the conditions under when the Heritage rate could be re-evaluated. Alternatively, the Heritage rate can be set by government based on an assessment of what’s the appropriate return to be earned and the underlying cost of providing the service.

## **Ensuring Appropriate Levels of Investment in Energy Efficiency and Demand Management**

In Newfoundland and Labrador, utilities’ incentives to aggressively pursue energy efficiency programs are muted by ratemaking practice, whereby fixed costs are recovered in energy charges such that reductions in load can result in reduced cost recovery and lower net income. This is similar to Nova Scotia; therefore, having an independent organization pursue such programs may be beneficial. However, this typically comes with an additional cost as reflected by the overheads associated with this organization.

## 7. System Reliability

### 7.1 Introduction

Electricity consumers evaluate the reliability of a power system in terms of the degree to which it supplies power to them in accordance with their requirements, i.e. sufficient amounts of power are available to them at the times they wish to receive it within the committed quality parameters such as voltage level. Many factors and processes impact the ability of power system operators to supply power to electricity consumers at the expected reliability levels. These include the ability to forecast those requirements accurately far enough in advance, the planning to establish how best to meet those requirements allowing for unexpected events, the timely implementation of the new facilities identified in the plan, adequate maintenance of all assets, operation of the assets safely and in an effective manner under various system conditions/circumstances as they arise and the ability and willingness of electricity consumers to pay for the level of reliability that they would like to have. This is illustrated schematically in Figure 39. Problems or shortcomings in any one of these aspects, and/or combinations of issues, can result in reliability levels that do not meet customer requirements.

**Figure 39: Key Factors in Meeting Customer Requirements**

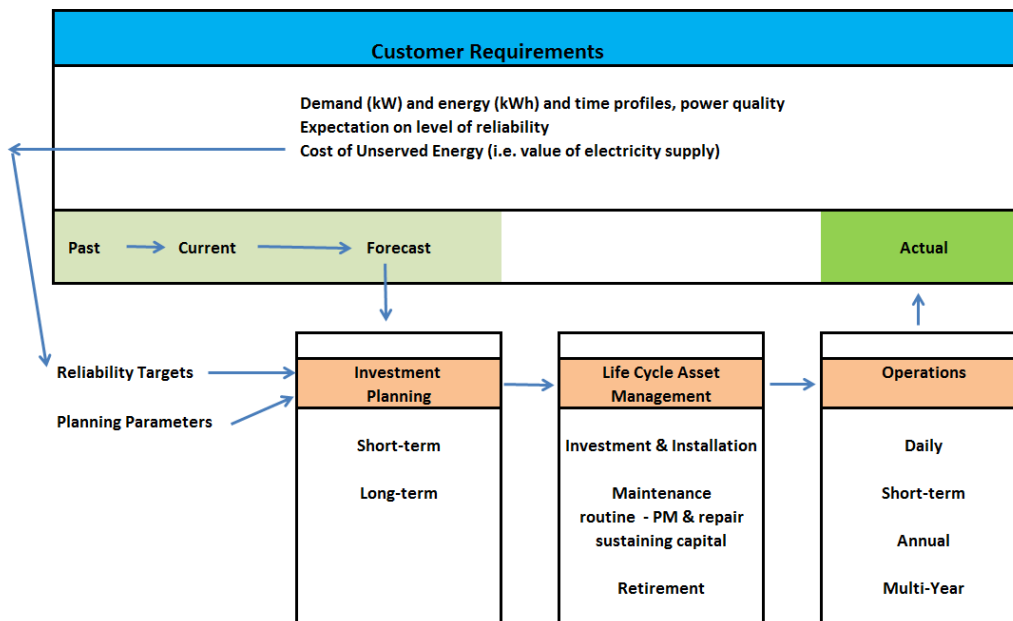

Source: Hatch

Practically speaking, power system operators and their regulators have to find the correct balance between reliability and costs and have established a wide range of procedures to allow this. Similarly, the industry has established various ways to measure reliability which allow comparisons between utilities. These will be outlined in this section.

## **7.2 Reliability Targets Used for Planning and Key Planning Parameters**

This section describes the reliability targets and planning criteria used by NLH and NP. These have been developed over time based on good utility practices and system specific factors. This is the approach that most electric utilities have used; however in many jurisdictions there have been opportunities for consumers and other stakeholders to review, assess and challenge the reliability targets and planning parameters in formal processes associated with the review of integrated resource plans. This best practice has not been fully followed in NL. As discussed, the decision to conduct and scope of such integrated resource plans depends in part on the jurisdiction's market structure.

### **7.2.1 Generation System Planning**

Responsibility for generation planning for the IIS and LIS rests with NLH. The PUB has the statutory responsibility to ensure adequate electrical system planning occurs in the province.

#### ***7.2.1.1 Generation and Reserve Planning Process***

NLH uses Ventyx's Strategist Model software to analyze and plan the generation requirements of the system. Strategist is an integrated strategic planning computer program that allows modeling of the current and future electric power system and which performs, among other functions, generation system reliability analysis, production costing simulation, and generation expansion planning analysis. It is the industry standard for generation planning and NLH has been using Strategist (or the versions of the software that preceded it) for many years. Nova Scotia Power Inc. (NSPI) has prepared several integrated resource plans (IRPs) using Strategist and prepared its 2014 IRP with Strategist and Plexos, which were filed with the Nova Scotia Utility and Review Board. Inputs to the model include load forecasts, the characteristics of the hydroelectric and thermal generation on the system, lifecycle cost and financial data.

All generating units in the model have an associated forced-outage rate, which leads to the unavailability of a generating unit for a set time. The forced outage rates used in this analysis are based on NLH's operations experience and/or industry norms from the Canadian Electricity Association.

Currently, no cost of carbon atmospheric emissions has been included in the analyses because of uncertainties regarding the timing, scope, and design associated with possible future regulatory initiatives in this regard. Demand management initiatives are not explicitly included in NLH's Strategist Model. Energy efficiency is integrated into NLH's load forecast through the use of an efficiency trend variable.

Generation planning is an iterative process. An initial generation expansion analysis is carried out using a load forecast developed based on projected economic and demographic factors, electricity tariffs and assumptions on energy efficiency improvements. The output from the least-cost generation expansion plan is fed into the NLH rates models. The rates that are generated in that

model are fed back into the load forecast model and the iterative process continues until the timing and choice of generation expansion options remains stable from one iteration to the next. The least cost generation plan is the one with the lowest cumulative present worth (CPW), which is the present value of all incremental utility capital and operating costs projected to be incurred by NLH to meet a specific load forecast given a prescribed set of reliability criteria. The outcome of the generation planning analysis is the alternative supply future with the lowest CPW, which will be recommended by NLH and is consistent with its mandate for least cost electrical service.

The use of Strategist for generation planning work is an industry best practice and NLH states that it is confident that the selection of Strategist and the way it represents the island system overall, is reasonable. This has been confirmed by several external reviews over the last several years in connection with MF. One aspect, in particular, where NLH determined that outside advice would be helpful, was forced outage rates/availability of the existing thermal equipment used in the model. Our comments on this are provided in Section 7.2.1.3.

### **7.2.1.2 Scenario Planning**

Scenario planning is a strategic planning methodology used to identify and assess the inherent risks and benefits of a long term plan. Scenario planning recognizes that many factors may combine in complex ways to create sometimes surprising futures. Scenario planning seeks to identify the causal relationship between factors and assess a plan's flexibility to adapt. Scenario planning develops an internally consistent story about the conditions in which the system might be operating in the future that differs from baseline assumptions in sometimes significant ways and usually involves alterations to all of the assumptions at one time. Sensitivity studies vary each of the assumptions either one at a time or in correlated groups to determine how sensitive the results are to changes in the assumptions. These planning techniques are important when there are variables such as weather that can impact the reliability of the system and capital cost that can potentially impact the investment plan. NLH has incorporated this technique in its planning.

### **7.2.1.3 Planning Criteria**

NLH has established criteria related to the appropriate reliability for the system at the generation level, which set the timing of generation source additions. These criteria set the minimum level of reserve capacity and energy installed in the system to ensure an adequate supply for firm demand. However, short-term deficiencies can be tolerated if the deficiencies are of minimal incremental risk, i.e. are not likely to have more than minimal consequences. As a general rule to guide NLH's planning activities, the following have been adopted:

- Capacity – The system should have sufficient generating capacity to satisfy an LOLH (Loss of Load Hours) expectation target of not more than 2.8 hours per year. LOLH is a probabilistic assessment of the level of un-served load at time of peak, due to insufficient generation

- Energy – The system should have sufficient generating capability to supply all of its firm energy requirements with firm system capability. Firm capability for the hydroelectric resources is the firm energy capability of those resources under the most adverse three year sequence of reservoir inflows, occurring within the historical record. Firm capability for the thermal resources (e.g. Holyrood Generation) is based on energy capability adjusted for maintenance and forced outages

These criteria have been in use by NLH for many years and NLH believes that they represent an appropriate balance between cost and reliability.

Initially, NLH used a Loss of Load Probability (LOLP) criteria established at 0.2 days per year, or one day in five years. When NLH replaced its original generation planning software in 1997, it was necessary to switch to a LOLH criterion. Benchmarking established that a LOLH of 2.8 hours per year was approximately equivalent to a LOLP of 0.2 days per year, for NLH's system. From that point, NLH established the capacity criterion that the system should have sufficient generating capacity to satisfy an LOLH target of not more than 2.8 hours per year. This does not mean customers can expect to lose generation for 2.8 hours each year, rather than over the long-term, system conditions may lead to an average loss of 2.8 hours per year in the period leading up to the next capacity addition. This capacity criterion is less stringent than that employed by large interconnected systems in the rest of North America. NLH has assessed this and considers this reasonable given that the IIS is not interconnected with other electric utility systems and there is no ready market for acquiring additional capacity or reserve sharing should a shortage be forecast. Reserve can only be increased by installation of additional, expensive generating equipment. NLH's criterion is based on the premise that the cost of providing a higher reliability level is in excess of the benefits to be derived (see Section 7.2.1.4). When NLH connects to the Nova Scotia grid, there will be a step change in reliability as well as the cost of alternatives available to enhance reliability as the interconnection will provide access to markets for reserve. At that time, NLH plans to reconsider its criteria and we understand from the NLH system planning group that the expectation is that NLH is likely to adopt a standard that brings NLH into alignment with other North American utilities.

Calculation of LOLP and LOLH involve mathematical procedures involving system load requirements and generating unit availabilities which take into account several critical parameters such as maximum continuous rating (MCR), scheduled outage (including both maintenance and planned outage), forced outage, derating and energy constraints (such as hydroelectric generation). If the assumptions for these parameters are not reflective of the actual system operations in the time period to which the planning applies, the level of reliability planned for may not be achieved. Appendix E further discusses some of the issues associated with establishing the appropriate LOLP and LOLH values.

The system LOLH is a function of the amount of capacity reserve. Lower LOLH or higher reserve will reduce the probability of supply-related interruptions while low reserve will increase the



probability of supply-related interruptions. Looking at reserve levels in this risk-based manner shows their similarity to purchasing an insurance policy; i.e., increasing reserves reduces outage risk, but at a cost. The amount of supply-related risk that utilities take results from many factors, and can vary. A common North American standard that has emerged seeks to achieve a level of reserves that would place the risk of a supply-related interruption at a 1 day in 10 years.

Based on our discussions with NLH, we understand that NLH has adopted the following practices in calculation of LOLH:

- 1) In forecasting system peak demand, NLH defines the worst day, in terms of wind-chill factor, in each year of the 30-year historical period and then averages those 30 data points. This average becomes the estimate of future weather used for planning purposes and the peak load associated with that wind-chill becomes the peak forecast. Using an average value produces a probability that the estimated peak load will be exceeded about every other year. Most utilities employ a higher (colder) wind-chill value, in order to reduce the probability that the forecasted peak will be exceeded as a result of colder than “average” worst-day weather. NLH has carried out sensitivity analysis on this and the planning procedures have been modified to reflect this by inclusion of a P90 weather factor (i.e. the probability of the actual load exceeding the forecast due to weather is 10%).
- 2) As NL’s electricity system experiences high load demand in the winter season (high use of electric heating) and low demand in the summer season, no scheduled maintenance is allowed from December 1 to March 31. This assumption is very reasonable. This assumption should be representative of the actual maintenance practice. If maintenance had to be performed during this window due to various reasons in the past, it should be reasonably reflected in the calculation of system LOLH. It is understood that in actual operation, a unit may be taken out of service for short duration maintenance if the forecast load is relatively low and the maintenance is not expected to affect supply adequacy.
- 3) Energy production is modeled outside Strategist due to the water storage available at many of NLH’s hydroelectric plants – some 80% of the installed capacity has large storage capability, in some cases multi-year. Firm energy is calculated based on the lowest water year in the last 60 years. In probabilistic assessment, most utilities use energy production capability under firm hydrological condition with 90% or 95% probability of exceedance to determine the timing of new unit additions and use energy production under average hydrological condition to estimate system production cost.
- 4) Comparing the FOR (or DAFOR) values used in LOLH calculation and the actual generators’ performance, it was found that the actual FOR values of thermal units are much higher than the ones used in LOLH calculation. NLH explained that the high FOR values were caused by extended forced outages during those periods of time these units would not be required. For example, repair of a forced outage occurred in summer months could be delayed as the system experiences very low load and the unit is not required for service.

NLH has now modified its planning procedures to use forced outage rates of 20% and 11.6% respectively for its gas turbines and the Holyrood units. As a sensitivity check NLH also runs the models using the levels of FOR experienced in 2014.

- 5) LOLH represents the amount of time when the full amount of the demand could not be met and as such it does not provide any measurement of the amount of energy that could not be supplied. NLH does not take into account the expected unsupplied energy (EUE) in its generation planning work. In addition to LOLH, many utilities also include EUE in preparation of least cost generation plans. EUE is typically expressed in terms of MWh per year or as a % of annual energy requirements and is used as a companion criterion to LOLH in planning studies such that if a certain level of EUE is projected this indicates the need for additional generation or firm purchases. It is understood from NLH's system planning group that NLH is considering incorporation of this parameter in its long-term planning in the future.

In preparation of its least cost generation expansion plans, NLH has not included two other costs in its analysis: the off-set allowance associated with greenhouse gas (GHG) emissions and other air pollutant emissions as well as costs to customers associated with interruptions. These two types of costs have been taken into account in generation planning by many electric utilities where there are markets for these emissions. In the case of an offset allowance for the costs of GHG emissions, once Muskrat Falls and the associated transmission systems are in place the percentage of thermal generation in NL will be about 2%. At present neither Newfoundland and Labrador nor Canada have established procedures where there are charges for GHG emissions. With respect to the costs customers incur due to service interruptions these are a real cost to society that should be considered in finding the appropriate balance between reliability and cost. This is illustrated further in Appendix F.

### **7.2.2 Transmission System Planning**

An electric power system is inherently required to instantaneously respond to the dynamic nature of electric power demand and changes occurring within. In order for that to be possible, electric utilities adopt "Planning Criteria" to maintain system adequacy under varying conditions.

At present, NLH does not adhere to NERC Reliability Standards in its planning process. However, it is expected that it will more closely follow NERC reliability standards after the Labrador-Island Link and Maritime Link are in service.

NLH has adopted an N-1 (single contingency) criterion to assess adequacy of its bulk transmission system on the Island and establish future expansion or reinforcement requirements. It is implied that N-1 conditions would not result in load shedding. NLH's Planning Criteria are described below:

- For normal conditions, the voltages at all the buses shall be maintained between 95% and 105%; and for contingency or emergency conditions, the voltages within 90% to 110% are considered acceptable;
- The bulk transmission system (i.e., 230 kV and 138 kV loops) is planned to be capable of sustaining single contingency (N-1) conditions, i.e. outage of any one transmission element without loss of system stability;
- In the event a transmission element is out of service, power flow in all other elements of the power system should be at or below normal rating;
- The NLH system should be able to sustain a successful single pole reclose for a line to ground fault based on the premise that all system generation is available;
- Transformer additions at all major terminal stations (i.e. two or more transformers per voltage class) are planned on the basis of being able to withstand the loss of the largest unit. For major 230 kV terminal stations with two or more transformers per voltage class (i.e., 230/66 kV or 230/138 kV) and for looped systems (i.e., two terminal stations supplying a local geographical area from two in-feed points) the capacity is selected such that the station or loop is able to supply the forecast peak load with the largest transformer out of service. Operation of standby generation such as a diesel plant and/or combustion turbine is considered for the transformer contingency. However, there are certain exceptions;
- For single transformer stations there is a back-up plan in place which utilizes NLH's and/or NP's mobile equipment to restore service; and
- The nameplate MVA rating of the transformer is not exceeded. If the transformer is provided with a 0 °C ambient temperature rating on its nameplate, then this rating is used to assess transformer capacity during winter peak load conditions.

In addition to the bulk transmission system, NLH plans its radial transmission system based on the following criteria:

- Radial transmission systems are planned to supply peak load with all elements in service;
- The single contingency loss of certain transmission elements could result in an interruption to some or all of the customers served by that system; and
- The *Corporate Business Continuity Planning* process has defined the maximum acceptable down times for the various elements of the radial systems and plans are in place to ensure service restoration within these timeframes.

The current transmission planning criteria require that there is no loss of load for the loss of a transmission line or power transformer with some exceptions. It also allows under frequency load shedding for loss of a generator in the IIS. This is not consistent with standard utility practice. It is understood that such load shedding is permitted because the system is isolated from the North American Grid and sufficient spinning reserve to respond to the loss of a generator is cost prohibitive. It is understood that in the revised criteria that NLH will apply after the Labrador-Island Link comes into service, it will likely be a requirement that the system should be able to sustain outage of a generator, which is an improvement towards enhancing reliability.

NLH has enhanced and elaborated the above criteria for transient stability after the HVdc projects come into service. The system response shall be stable and well damped following a disturbance. The system disturbances include:

- Successful single pole reclosing on line to ground faults
- Unsuccessful single pole reclosing on line to ground faults
- Three phase faults, except a three phase fault on, or near, the Bay d'Espoir 230 kV bus, with tripping of a 230 kV transmission line
- Loss of the largest generator on line on the IIS with and without fault
- Line to ground or three phase fault with tripping of a synchronous condenser
- Fault and tripping of a series compensated 230 kV transmission line with the series compensation device out of service on the in service parallel 230 kV transmission line
- Temporary pole fault
- Permanent pole fault
- Temporary bipole fault
- Post fault recovery voltages on the ac system shall be as follows:
  - Transient under voltages following fault clearing should not drop below 70%
  - The duration of the voltage below 80% following fault clearing should not exceed 20 cycles
- Post fault system frequencies shall not drop below 59 Hz
- Under frequency load shedding
  - shall not occur for loss of on island generation with the HVdc link in service

- shall not occur for permanent loss of HVdc pole
- shall not occur for a temporary bi-pole outage
- shall be controlled for a permanent bi-pole outage
- there shall be no commutation failures of the HVdc link during post fault recovery

There is no transformer overloading criteria used at the planning stage. However, NLH's Energy Control Centre (ECC) maintains a transformer loading guideline for emergency conditions with acceptable overload levels based upon ambient temperature.

- Most radial systems employ only single transformer stations. There is a back-up plan in place which utilizes NLH's and/or NP's mobile equipment to restore service;
- In areas where suitable backup transformation cannot be identified installed redundancy is applied.

In general, the geography of Newfoundland and Labrador poses significant challenges to provide and operate a reliable electric system. In particular, heavy wind and ice loading in the eastern region where the load is concentrated establish the requirements and special considerations regarding design and operation of the electricity system to maintain an acceptable level of reliability.

Accepting loss of load seems to be a long standing practice to reduce capital investment, keeping in view that transformer faults and interruption of load is a rare phenomenon. Two examples of acceptance of loss of load are:

- NLH considers an exception for three phase faults on, or near, the Bay d'Espoir 230 kV bus with tripping of a 230 kV transmission line, and it is currently planned that this will continue to be the case even after the Labrador-Island Link HVdc link. This exception is not an established utility best practice. Ideally, after the Labrador-Island Link HVdc is in place, the system should be at least able to sustain a three phase fault anywhere in the system followed by tripping of a 230 kV line or a generating unit. NLH advises that under normal operations at peak load conditions and three synchronous condensers in operation this would not occur but would apply if one of the three condensers was on forced outage. NLH has judged that the substantial cost of the additional synchronous condenser needed to avoid this situation are not warranted.
- At certain locations, NLH accepts short term customer load loss for a customer contingency while the failed transformer is isolated and the ECC coordinates the restoration of service. It is, however, not recognized best practice to accept loss of

customers due to loss of a transformer at substations where more than one 230 kV transformer is provided.

Recent incidents indicate the need to review the entire system configuration and further explore the possibilities for reliability improvement and such analysis is underway by NLH.

Bulk power system planning on the basis of the N-1 criterion is a generally accepted utility practice. It is also common to apply more stringent criteria to certain facilities which are considered very critical. For example, N-1 contingencies associated with breaker failure are commonly accepted as credible contingencies under which the system should remain stable and within emergency limits (for instance in PJM, AESO with controlled load shedding and NSPI).

The original 230 kV terminal station layouts were simple load bus arrangements which developed over time. Several 230 kV terminal station bus arrangements have been modified to improve overall system reliability. NLH's preference is for either ring bus or breaker-and-half arrangements as appropriate for the number of elements.

Keeping in view the Holyrood incident that occurred on January 11, 2013 and the incident that occurred on December 2, 2007 at which time the TL-203 transmission line tripped leading to a chain of events that culminated in the two operating units at Holyrood tripping, it would be prudent to investigate and establish the consequences of more severe contingencies. As another example, a 230 kV line end fault at Hardwoods Terminal Station with breaker failure may lead to shut down of more than half of the station. Similarly, a breaker failure at Oxen Pond may result in shut down of that terminal station. Such investigation would provide an estimate of the magnitude of the consequences and the possibility of containing the spreading of the problem arising from such contingencies. As such, they may not necessarily warrant the need for capital investments.

The Labrador-Island Link HVdc link between Newfoundland and Labrador, together with the closure of Holyrood generating units and retirement of Hardwoods GT, would entirely alter the transmission system's behaviour with respect to power flow and dynamic performance. The new Soldiers Pond substation would be integrated into the existing system in such a way that there is no transmission line addition.

After the Labrador-Island Link HVdc is in service, the existing Hardwoods and Oxen Pond substations would become very critical for the reliability of power supply to St. John's area. The 230 kV breakers at Hardwoods (B1L01 and B1L36) and Oxen Pond (B1L36 and B1L18) are air blast type. It is understood that NLH plans to replace the existing breaker B1L01 at Hardwoods and B1L36 at Oxen Pond. It is also understood that Hydro has a *Plan for Annual Exercise of Air Blast Circuit Breakers*. However, it is considered important that the integrity of the above mentioned breakers is reassessed and it may also be appropriate to review the 230 kV switchgear configurations to enhance their reliability.

### 7.2.3 Distribution System Planning

Both NLH's and NP's capacity planning criteria for their distribution systems are consistent with good utility practice. These criteria are described below.

#### NLH

- A. Normal Voltage — Based on CSA CAN3-C235-83 ("Preferred Voltage Levels...") and the CEA "Distribution Planner's Guide".
- B. Load — Equipment loading no greater than 100% rating.
  - a. conductor ampacity adjusted for appropriate temperature during peak.
  - b. short term overloading on transformers permitted.
- C. Voltage Flicker Limit — maximum of 5% voltage flicker.

#### NP

NP's transmission lines (defined as lines operating at 66 kV or higher voltages) are not part of the 230 kV bulk power grid. This transmission system connects NP's distribution substations to the delivery points in NLH's 230 kV bulk power system. NP's transmission lines are not designed to meet the same reliability criteria as NLH's 230 kV bulk transmission network

NP's planning of its transmission and distribution system is aligned with the Distribution Planner's Guide published by CEA, as follows:

- D. Normal Voltage - Based on CSA CAN3-C235 ("Preferred Voltage Levels...")
- E. Capacity Criteria - Based on CSA C22.3 No. 1 - Overhead Systems
  - For conductors - maximum allowable conductor temperature under normal seasonal ambient temperature and wind conditions
  - For transformer - Name plate rating of transformer
  - Short Circuit - Maximum clearing time to be within the withstand capability of the component involved
- F. Reliability Criteria - None.

As noted from the reliability statistics reviewed below, the planning and design of NP's system has been effective, indicating the appropriate redundancy, design standards, criteria, and practices.

Liberty<sup>216</sup> has recommended extending the use of SCADA and automatic re-closers to minimize interruption frequencies and durations. Also, completion of in-process developments in the

---

<sup>216</sup> The Liberty Consulting Group Newfound Power Report-12-17-2014

Geographic Information System will increase its effectiveness. Liberty has also indicated that NP's protective relays schemes conform to industry practice, but require documented guidance. Power Advisory supports Liberty's recommendation that NP address the lack of a program requiring periodic exercising of circuit breakers and that it begin to track centrally actions to address the causes of frequent protective device operations.

#### **7.2.4 Planning of Remote Isolated Micro Systems**

Communities that are not connected to the LIS or IIS depend on small diesel-generating plants. Despite the substantial operating costs of these systems, the cost of interconnecting them or developing renewable generation is typically still greater. Therefore, many isolated communities will continue to be served by diesel generation, as it is the most feasible and cost-effective way to provide reliable electrical service. The costs of these isolated systems are currently being subsidized in the order of 75 percent by other residential rate payers in the province.<sup>217</sup>

NLH provides electricity to customers connected to 21 remote isolated micro systems. NLH applies the following two criteria in planning these micro systems:

- The micro system should have sufficient firm capacity to supply the peak load of the system. Firm generation capacity is defined as the total installed capacity on the system minus the largest unit
- In each system NLH installs a minimum of three units to meet the load requirements of the system

These criteria imply that each micro system will meet the "N-1" contingency criterion, which is used by many utilities for micro system planning.

### **7.3 Operational Reserves**

#### **7.3.1 Operating Reserve**

From an operational perspective, NLH manages generation resource availability on the system and schedules generating units out of service for planned maintenance in order to meet the (N-1) system contingency reserve criterion. In this manner, sufficient reserve is planned to be available to meet the system load under a contingency of the largest (MW rating) available generating unit becoming unavailable. NLH does not rely on capacity from wind and other non-dispatchable resources to provide reserve. NLH's generation planning assessment takes into account this non-dispatchable nature, and under most operating conditions, there is more than enough firm dispatchable generation available to meet peak loads. The non-dispatchable generation, when available, increases the level of generation available as reserve.

---

<sup>217</sup> Energy Plan – Focusing Our Energy, Government of Newfoundland and Labrador, 2007



Following the (N-1) criterion requires that NLH not allow any extended planned maintenance to be scheduled during the winter period. However, if the short-term load forecast permits, NLH may take the opportunity to schedule a short-duration generating unit outage to address running or corrective maintenance issues.

### 7.3.2 Maintaining Spinning Reserves

The ECC will maintain sufficient spinning reserves to cover performance uncertainties in generating units, especially wind and other variable generation (e.g., run of river hydro), and unanticipated increases in demand. The ECC will take appropriate action to maintain a minimum spinning reserve level equal to 70 MW. Such actions include the following: placing in service all available generating capacity, cancelling outages to generating units that have a short recall, deploying all available standby resources, invoking industrial interruptible load contracts and reducing system load; through procedures such as public conservation notices, and voltage reductions.

Currently, the size of the largest generating unit is 170 MW and the minimum spinning reserve requirement is 70 MW. The details on the system operation under different levels of generation reserve are described in the next section (Section 7.3.3).

### 7.3.3 Available Generation Reserve

In order to ensure that reliability is maintained, the ECC exercises its authority to reduce risks to the generation supply and maintain sufficient generation reserves to meet current and anticipated customer demands. The ECC is prepared to deal with generation shortages and take appropriate actions in order to maintain the reliability of the IIS.

Generation reserve<sup>218</sup> is required to replace generation capacity lost due to an equipment forced outage, to cover performance uncertainties in generating units or to cover unanticipated increases in demand. Sufficient generation reserve is required to meet current and forecasted demands under a contingency of the loss of the largest generating unit. Unlike other utilities in defining operating reserve requirements, NLH uses the term of available generation reserve to ensure the system has sufficient operating reserve.

The available generation reserve<sup>219</sup> for the IIS is calculated for the current day and the following four days in the manner indicated below:

Available generation reserve for each day =

Available generation of NLH (hydro + thermal + standby<sup>220</sup> + Purchase<sup>221</sup>) plus

---

<sup>218</sup> Generation Reserve is defined as the quantity of available generation supply that is in excess of demand, including spinning reserve (unloaded generation that is synchronized to the power system and ready to serve additional demand). It is equal to available generation supply less current/forecasted demand.

<sup>219</sup> Available generation reserve is associated with generation that is in service or standby generation that can be placed in service within 20 minutes. NP's mobile generation may take up to 2 hours to place in service.

Available generation of NP (hydro + standby) plus

Available generation of DLP (hydro) less forecasted peak (demand from NLH, NP and CBPP)

The available generation reserve will be calculated and assessed against the criteria listed below and a notification will be issued to stakeholders when available generation reserve is below the stated thresholds.

Available Reserve	Expected Action	Level
> Largest Generating Unit + min. spinning reserve		None 0
< Largest Generating Unit + min. spinning reserve potential	1 Load reduction	Prepare for
< Largest Generating Unit	Load reduction	2
< 1/2 Largest Generating Unit	Conservation	3
Zero/deficit; hold f=59.8 Hz	Rotating outages	4

Based on the assessment above, the ECC will perform the following activities:

- Level 0 - If the available reserve is anticipated to be greater than the largest available generating unit capacity plus minimum spinning reserve, the ECC is not expected to perform any further actions, other than to advise Executive On-call (CERP), Corporate Relations and NP that available reserve has returned to normal following a prior Level 1, 2, 3 or 4 notice
- Level 1 - If the available reserve is anticipated to be less than the largest available generating unit capacity plus the minimum spinning reserves, the ECC will notify NP's Control Centre, advising of possible requirements for load reduction to maintain sufficient spinning reserves, if the available generation reserve should decrease
- Level 2 - If the available reserve is anticipated to be less than the largest available generating unit capacity, the ECC will notify Executive On-call, Corporate Relations and NP, advising of load reduction strategies to maintain sufficient spinning reserve, if the generation shortfall is not corrected

<sup>220</sup> Standby generation includes combustion turbine and diesel generation.

<sup>221</sup> NLH's Purchase includes wind for the current day based on actual wind output but assumes no wind generation for the following four days.

- Level 3 - If the available reserve is anticipated to be less than half of the largest available generating unit capacity, the ECC will notify Executive On-call, Corporate Relations and NP, advising of customer conservation strategies to help maintain sufficient spinning reserves, if the generation shortfall is not corrected
- Level 4 – If the available reserve is anticipated to approach zero or fall into a deficit, the ECC will notify Executive On-call, Corporate Relations and NP, advising of rotating outages to help maintain frequency near the 60 Hertz standard, if the generation shortfall is not corrected

### **7.3.4 Post Interconnection of Muskrat Falls Hydroelectric Plant**

#### ***7.3.4.1 Spinning Reserve Requirement***

In response to the PUB Review of Island Interconnected System Supply Issues and Power Outages, NLH provided the following response regarding spinning reserve indicating the increase in the minimum spinning reserve which it intends to move to after the Labrador-Island Link is in place<sup>222</sup>:

Following the completion of the Labrador - Island HVdc Link (LIL) and the shut-down of the Holyrood Thermal Generating Station as a producer of electric power and energy to meet the Island Interconnected System load, the largest on line generator on the Island Interconnected System will be Bay d’Espoir Unit 7, rated at 154 MW. In order to ensure that the loss of the largest unit on the Island does not result in under frequency load shedding with the LIL in service, a minimum of 154 MW of spinning reserve must be maintained on the ac system.

NLH indicated that this matter will be further assessed in upcoming analysis work and decisions will then be reached on the operating criteria to be followed.

#### ***7.3.4.2 Power Supply Concerns for the Avalon Peninsula Area***

In addressing the power supply concerns for the Avalon Peninsula area, NLH performed an analysis and indicated the following:<sup>223</sup>

When considering the Avalon Peninsula, the pre-Muskrat Falls and post-Muskrat Falls supply picture changes significantly. NLH’s transmission planning criteria requires the system to be able to supply peak load with a single transmission element out of service. In the application of these criteria, regional generation is assumed available to supplement the remaining transmission capability.

---

<sup>222</sup> PUB-NLH-495

<sup>223</sup> CA-NLH-081, NLH’s response to the PUB Review of Island Interconnected System Supply Issues and Power Outages

The current Avalon Peninsula peak load is approximately 840 MW and is anticipated to grow to around 920 MW by 2020.<sup>224</sup> For the pre-Muskrat Falls scenario for a single contingency loss on the Bay d’Espoir to Western Avalon transmission corridor the supply capacity to the Avalon Peninsula would be approximately 603 MW (from local generation),<sup>225</sup> 726 MW considering the new Holyrood combustion turbine plus 370 MW (via the Bay d’Espoir to Western Avalon corridor), for a total capacity of 973 MW to 1096 MW. In the post-Muskrat Falls case, the most onerous transmission contingency would be for the rare occurrence of the complete loss of the 900 MW LIL. During this contingency, the supply capacity available to the Avalon Peninsula would be 257 MW<sup>226</sup> from local generation and up to 966 MW<sup>227</sup> via the Bay d’Espoir corridor for a total of 1223 MW. In fact, considering the double contingency of the total loss of the LIL and one circuit in the Bay d’Espoir to Western Avalon Transmission corridor, the remaining supply capacity would still be 676 MW<sup>228</sup> via the Bay d’Espoir to Western Avalon corridor plus 257 MW from local generation for a total supply capacity of 933 MW. Thus, the post-Muskrat Falls configuration will provide enhanced reliability for customers on the Avalon Peninsula.

While reviewing the configurations of terminal stations, exceptions are noted to generally accepted utility practices. An example is the Western Avalon substation where there are no breakers on either side of the 230/138 kV transformers. Such configuration at a substation essentially provides no firm capacity as any transformer fault or 230 kV bus fault (transferred on breaker failure) would lead to loss of load because the 230 kV bus must be tripped. Power Advisory expects that improvements in the risks posed by this configuration will continue over time due to equipment replacement, upgrading or expansion.

### **7.3.5 Interconnection with Nova Scotia System**

After interconnection with the Nova Scotia system and interconnection of Muskrat Falls into the IIS, it is expected that available generation reserve requirements (or operating reserve) will change. NLH has indicated that the required available generation reserve would be established by subsequent work and NLH has been in discussion with Nova Scotia on reserve sharing.

## **7.4 NERC Reliability Standards**

### **7.4.1 Overview**

This section reviews the role of NERC as the approved Electric Reliability Organization (ERO) for North America, examines how a NERC centered reliability framework has been implemented in

---

<sup>224</sup> This includes NP Avalon load plus Vale and Praxair industrial load.

<sup>225</sup> Local generation includes the Holyrood thermal generation station plus NLH and NP’s standby generation on the Avalon Peninsula (does not include new Holyrood combustion turbine).

<sup>226</sup> Includes the existing NLH and NP standby generation and the new Holyrood combustion turbine.

<sup>227</sup> Assumes new Bay d’Espoir to Western Avalon transmission line and additional voltage support provided by the Soldier’s Pond synchronous condenser plant.

<sup>228</sup> Assumes additional voltage compensation provided by the Soldier’s Pond synchronous condenser plant.

various Canadian provinces, and outlines alternative structural arrangements for addressing any reliability compliance monitoring and enforcement obligations in Newfoundland and Labrador.

The current framework for reliability of the bulk electric system in North America has its origins in the Northeast Blackout of 1966. As a result, the National Electric Reliability Council and regional reliability councils, comprised predominantly of member electric utilities, were formed in the United States. Within a few years bordering utilities in Canada and northern Mexico joined the various regional councils necessitating a name change from “National” to “North American” but preserving the NERC acronym. Reliability standards and criteria evolved over time, but continued to be subject to voluntary compliance by the member utilities and enforcement was through publication of non-compliance, mainly by the regional reliability councils.

Following the Northeast Blackout of 2003, the US government passed the 2005 *Energy Policy Act* which included provision for mandatory compliance of reliability standards to be developed by an ERO subject to US Federal Energy Regulatory Commission (FERC) jurisdiction. Also in 2005 a document entitled “*Principles for an Electric Reliability Organization that can Function on an International Basis*” was developed by the joint Canada-US Bilateral Electric Reliability Oversight Group<sup>229</sup> and agreed to by the US and Canadian federal governments and various Canadian provinces and territories. A primary objective of these initiatives was to establish a reliability organization that could enforce reliability standards and reduce the risk of such widespread outages in the future. NERC was the entity that was charged with this responsibility, subject to oversight by FERC in the US and various governmental authorities. While NERC does not have jurisdiction in Canada, almost all provinces have either adopted or are in the process of adopting all or some of the NERC reliability standards. The NERC reliability standards have essentially become the industry standard for utilities to follow to achieve reliable operation of their power grids.

#### **7.4.2 Application to Canadian Provinces**

When the entire province of Newfoundland and Labrador is directly connected to the North American grid, a decision will need to be made if the province will seek to comply with NERC reliability standards and if so, which standards are appropriate. In addition, if the province is going to adopt various NERC reliability standards it will need to determine how it will monitor and enforce compliance with these standards. The remaining discussion in this section outlines alternatives for this.

There are three fundamental questions that need to be addressed: (1) what electricity sector participants will have responsibilities for the various critical functions; (2) what form will the agreements with NERC take (e.g., memorandum of understanding); and (3) what, if any, legislative changes are required to enable parties to take on these responsibilities.

---

<sup>229</sup> The “Bilateral Principles” document can be found under the heading “Other Publications of Interest” at <http://www.electricity.ca/industry-issues/economic/reliability.php>

The discussion below focuses on how these questions were addressed in BC, Saskatchewan, Manitoba, Québec, New Brunswick and Nova Scotia.<sup>230</sup> The agreements for each province deal with four main issues.

- Recognition of NERC as a standards authority “whose mission as the ERO is to promote the reliability of the bulk power system in North America”, and recognition of the specific provincial authority of the regulator over reliability in Québec, Nova Scotia, and New Brunswick; and SaskPower as the authority for Saskatchewan. In its role as standards authority, NERC typically develops the reliability standards in a stakeholder process.
- Reliability standards are to be developed by NERC, but are subject to approval or remand by the provincial authority through a provincial process.
- Compliance monitoring will be done on behalf of NERC by a Regional Reliability Organization (MRO for Manitoba and Saskatchewan, and NPCC for Quebec, New Brunswick and Nova Scotia); a compliance registry is required but responsibility for maintaining such a registry varies by province (often it resides with regional reliability council such as in Manitoba or the Crown utility, e.g., in Québec)<sup>231</sup>; and enforcement is performed by the provincial authority including imposing monetary sanctions.
- Funding of NERC and the respective regional reliability organization is to be by the provincial utilities for the services provided on a load for energy share.

While BC does not have a formal MOU with NERC it does adhere to the four MOU issues through BC Hydro membership in NERC and WECC, the legislated authority of the BCUC to approve and enforce reliability standards,<sup>232</sup> recognition of NERC and WECC as “standard making bodies” in legislation, and establishment by BCUC of WECC as administrator for the Compliance Monitoring Program.<sup>233</sup>

In 2009, the British Columbia Transmission Corporation submitted an Assessment Report to the BC Utilities Commission (Commission) regarding various WECC and NERC reliability standards. In response, the Commission adopted 103 reliability standards and subsequently adopted Rules of Procedure, Registration Manual and Compliance Monitoring Program for reliability standards in

---

<sup>230</sup> Alberta and Ontario aren’t reviewed because they have fundamentally different structures for their electricity systems. PEI isn’t reviewed because it relies on New Brunswick for many of these functions.

<sup>231</sup> There are numerous functions which appropriately reside with the local electric utilities or electricity sector market participants including reliability coordinator, transmission planner, etc.

<sup>232</sup> Specifically, the provincial government amended the *Utilities Commission Act* by adding Section 125.2, which gave the Commission jurisdiction to adopt reliability standards for British Columbia.

<sup>233</sup> Beginning in January 2014, WECC roles were bifurcated, with WECC serving as the Regional Entity and Peak Reliability as the reliability coordinator. This is in response to conflict of interest concerns raised by NERC in regard to WECC’s handling of an outage in September 2011. The mission statement of Peak Reliability Company is to: “support and promote the social welfare by endeavoring to ensure reliability by providing real-time, Interconnection-wide oversight of the Bulk Electric System (BES) within the Reliability Coordination Company footprint, coordinating necessary real-time and seasonal planning and modeling, and ensuring that data critical to the reliable and efficient operation of the BES is shared appropriately.”

British Columbia and appointed WEEC as administrator to assist the Commission in carrying out the registration of parties and compliance monitoring. Interestingly, some stakeholders suggest the BCUC lacks the capacity to regulate and monitor these reliability standards, while BC Hydro has the expertise but does not want to incur additional costs, risks, or responsibilities.

New legislation was introduced in BC, Manitoba, Quebec, and New Brunswick to provide authority to the provincial regulator for approval regarding mandatory reliability standards and to clarify processes for standards adoption, compliance and enforcement.

- In BC<sup>234</sup> and Québec<sup>235</sup> the regulator has total authority but it also places much reliance and responsibility on the provincial utility to assist in the work. The utilities maintain the Compliance Registry, review any standards and provide reports to the regulator regarding the potential impacts, implications and costs of implementing the standard in the province. In Québec the Reliability Coordinator section of Hydro-Québec also handles the compliance process and maintains all documents on its site while in BC the regulator maintains all documents on its site.
- In Manitoba<sup>236</sup> the standards are those adopted by NERC and/or MRO as set out in Schedule 1 of the Regulation. Government was given authority to suspend, disallow, or approve adoption of these standards, with Manitoba Hydro typically advising it. Monitoring and compliance is conducted by NERC and MRO according to the Compliance Monitoring and Enforcement Program (Manitoba) which is Schedule 2 of the Regulation. Violations and suggested sanctions are filed by MRO with NERC and the Manitoba PUB establishes whether there was non-compliance and the fines for any violations. The PUB also has dispute resolution responsibilities for disputes between NERC and MRO, who are responsible for monitoring the standards, and parties who are required to comply with the standard.
- In New Brunswick<sup>237</sup> the regulator has total authority for approval of standards, maintenance of a provincial Compliance Registry, monitoring and compliance of standards and issuing of sanctions for non-compliance. NB Power must file for approval of standards within 60 days of the approval of a NERC generated standard by FERC along with a report of the potential impacts for New Brunswick.

Nova Scotia did not enact new legislation as the UARB had authority under existing legislation. NERC makes quarterly filings directly to the UARB for approval of any standards that have been

---

<sup>234</sup> BC legislation passed in May 2009 is the “Utilities Commission Amendment Act” which is available at [http://www.bclaws.ca/EPLibraries/bclaws\\_new/document/ID/freeside/00\\_96473\\_01#part1](http://www.bclaws.ca/EPLibraries/bclaws_new/document/ID/freeside/00_96473_01#part1)

<sup>235</sup> Quebec legislation in Dec 2006 (Bill 52) amended the Regie Act to include reliability standards in Section 85 which is available at [http://www.regie-energie.qc.ca/regie/Loi/Loi\\_RegieEnergie\\_ENG.pdf](http://www.regie-energie.qc.ca/regie/Loi/Loi_RegieEnergie_ENG.pdf)

<sup>236</sup> Manitoba legislation amends both the Manitoba Hydro Act and the Public Utilities Board Act and is available at <http://web2.gov.mb.ca/bills/39-3/b020e.php>. The Reliability Standards Regulation provides greater detail at <http://web2.gov.mb.ca/laws/regs/current/pdf-regs.php?reg=25/2012>

<sup>237</sup> New Brunswick legislation concerning Reliability Standards is in Part 7 Sections 118-124 of the Electricity Act 2013 which is available at <http://laws.gnb.ca/en/ShowTdm/cs/2013-c.7/>. The Reliability Standards Regulation provides greater detail on the framework and is located at the same web site.

approved by FERC in that quarter. The UARB considers comments from Nova Scotia Power and others prior to approval or remand. Compliance registry and monitoring is done by NPCC and enforcement sanctions if needed are done by the UARB based on input from NPCC and NERC.

Saskatchewan is the only jurisdiction that has retained all provincial authority for reliability within the provincial utility. This is accomplished through a distinct reliability “Oversight Authority” and a compliance program not linked with operations has been established within SaskPower to manage the Province’s reliability framework. While the process is considered “interim” in the MOU it apparently has been developed to a point where it is considered to be a full regulatory framework by the province.

### **7.4.3 Assessment**

The alternatives for addressing the reliability compliance and enforcement obligations reviewed above indicates that these can be taken on by three primary parties in electricity sectors with vertically integrated electric utilities: (1) the utility; (2) the government; or (3) the regulator. As stakeholder comments in BC make clear, an important consideration as to whom these responsibilities should be allocated is who has the necessary expertise and knowledge to best perform them. While organizations can acquire this expertise and knowledge, if it resides in other organizations in the province, it is more efficient to have these organizations perform these functions. Offsetting this consideration is the need for independence when assessing compliance and taking enforcement actions. Given that utilities have responsibilities as the reliability coordinator in most provinces, having them also responsible for compliance monitoring and enforcement can be viewed as a conflict of interest. In addition, where there are multiple utilities in the province having one have a compliance monitoring and enforcement role may be problematic. This is less of an issue in Newfoundland and Labrador given that virtually all of NP’s facilities are unlikely to be affected by such reliability standards given the lower voltage ratings of its transmission facilities and small size of generation facilities. Nonetheless, this argues for having the regulator have responsibility for establishing non-compliance, with input from NERC, NPCC, or NLH, for establishing fines and adjudicating disputes.

### **7.4.4 NLH Review to Date**

In identification and assessment of the major impacts due to interconnection of NL into the North American power grid, Nalcor has prepared the following two reports<sup>238</sup>:

- 1) Strategic Alignment, Benefits, Reliability Framework and Compliance – NERC Reliability Standards and NPCC Regional Reliability Criteria
- 2) Cost Assessment – NERC Reliability Standards and NPCC Regional Reliability Criteria for Nalcor

---

<sup>238</sup> <http://www.pub.nf.ca/applications/IslandInterconnectedSystem/files/rfi/PUB-NLH-157.pdf>



The report on Cost Assessment prepared by Nalcor indicates that there are approximately 120 NERC reliability standards, which can be categorized as follows:

- 1) Resource and Demand Balancing
- 2) Communications
- 3) Critical Infrastructure Protection
- 4) Emergency Preparedness and Operations
- 5) Facilities Design, Connections, and Maintenance
- 6) Interchange Scheduling and Coordination
- 7) Interconnection Reliability Operations and Coordination
- 8) Modeling, Data, and Analysis
- 9) Nuclear
- 10) Personnel Performance, Training, and Qualifications
- 11) Protection and Control
- 12) Transmission Operations
- 13) Transmission Planning
- 14) Voltage and Reactive

Based on the functional entity determination for Nalcor, there are 101 NERC reliability standards and nine Critical Infrastructure Protection (CIP) standards that would be applicable for assessment. The following list outlines the number of reliability standards that would apply to each of the reliability standard categories:

- 1) Resource and Demand Balancing – There are 6 reliability standards applicable in this category
- 2) Communications – There are 2 reliability standards applicable in this category
- 3) Critical Infrastructure Protection – There are 9 reliability standards applicable in this category
- 4) Emergency Preparedness and Operations – There are 7 reliability standards applicable in this category
- 5) Facilities Design, Connections, and Maintenance – There are 10 reliability standards applicable in this category
- 6) Interchange Scheduling and Coordination – There are 9 reliability standards applicable in this category

- 7) Interconnection Reliability Operations and Coordination – There are 13 reliability standards applicable in this category
- 8) Modeling, Data, and Analysis – There are 19 reliability standards applicable in this category
- 9) Personnel Performance, Training, and Qualifications – There are 4 reliability standards applicable in this category
- 10) Protection and Control – There are 17 reliability standards applicable in this category
- 11) Transmission Operations – There are 8 reliability standards applicable in this category
- 12) Transmission Planning – There are 4 reliability standards applicable in this category
- 13) Voltage and Reactive – There are 2 reliability standards applicable in this category

Based on the Functional Entity determination for Nalcor, there are 10 NERC reliability standards that would not be applicable for assessment. The following list outlines the number of reliability standards that would not apply to each of the reliability standard categories.

- 1) Modeling, Data, and Analysis – There are 2 reliability standards that would not be applicable in this category
- 2) Nuclear – There is 1 reliability standard that would not be applicable in this category
- 3) Protection and Control – There are 5 reliability standards that would not be applicable in this category
- 4) Transmission Planning – There are 2 reliability standards that would not be applicable in this category

The Nalcor Study has classified the 110 NERC reliability standards into three groups, required, not required and optional for Nalcor as follows:

- 1) Required reliability standards -- There are a total of 10 reliability standards that have been assessed as required. They are in the Interchange Scheduling and Coordination (9 standards) and the Resource and Demand Balancing (1 standard) categories
- 2) Not Required reliability standards – There are a total of 8 reliability standards that have been assessed as not required. They are in the Modeling, Data and Analysis (4 standards) and Protection and Control (4 standards) categories

- 3) Optional reliability standards -- There are a total of 92 reliability standards that have been assessed as optional. One or more of these are in each of the categories of the NERC reliability standards that are applicable to Nalcor. However, consulting firm Acumen Engineered Solutions International Inc. (AESI) has recommended that many standards identified as optional need to be reconsidered. The AESI report should be referred to for details and is discussed further below.

In April 2015, Nalcor engaged an external consultant AESI to conduct an assessment of Nalcor's internal assessment of the potential requirements and implications of adopting the NERC reliability standards and the NPCC regional reliability criteria along with the cost assessment for Nalcor and its other subsidiaries to adopt these standards and criteria.

AESI's report<sup>239</sup> provides a detailed assessment of Nalcor's internal reports and next steps to be followed. AESI's findings and recommendations result from an assessment of Nalcor's report and cost assessment to help Nalcor validate that the cost projections are reasonable and inclusive of all costs that need to be considered using a very conservative approach and to factor in the changes to the NERC standards.

AESI did not review any existing documentation, processes or procedures and the main focus was on the resources and cost estimate for developing the necessary compliance program.

The most important recommendation in AESI's report is to conduct "a more thorough and comprehensive gap assessment with the various Nalcor SMEs [Subject Matter Experts]" and reviewing any existing documentation, processes, and procedures to see how they map with the requirements of the Non-CIP (FERC Order 693) and CIP v5 (FERC Order 706/791) Standards. The results of the gap assessment would then be used to develop an implementation plan/road map, identify the required resources (both internal and external) and more definitively, establish the budget and timeline for Nalcor to implement a compliance program for applicable NERC standards (non-CIP and CIP) and NPCC Directories.

Another important observation made by AESI is that "The Interconnection Operating Agreement (IOA) with NSPI places specific reliability obligations on Nalcor, with many of them closely aligned to NERC Reliability Standards."

AESI has indicated that "there have been numerous changes to Reliability Standards, the introduction of a number of new standards and the replacement of various standards that must now be factored in" and provides a comprehensive list of the standards which AESI believes are pertinent to their assessment.

---

<sup>239</sup> External Validation of NERC Reliability Standards and NPCC Regional Reliability Criteria Requirement, dated April 28, 2015

#### 7.4.5 NPCC Regional Reliability Criteria

There are also Regional Reliability Organizations (RRO) across North America that work in coordination with NERC to ensure the reliability of the power grid by region. They may have their own reliability standards or criteria that are specific to their region. They are also mainly responsible for the compliance monitoring and enforcement of the reliability standards for their region. The RRO responsible for the north-eastern region of North America (adjacent to Newfoundland and Labrador) is Northeast Power Coordinating Council (NPCC).

NPCC has 11 directories containing the regional reliability criteria, which can be categorized as follows:

- 1) Directory #1 – Design and Operation of the Bulk Power System
- 2) Directory #2 – Emergency Operations
- 3) Directory #3 – Maintenance Criteria for BPS Protection
- 4) Directory #4 – System Protection Criteria
- 5) Directory #5 – Reserve
- 6) Directory #6 – Reserve Sharing Groups
- 7) Directory #7 – Special Protection Systems
- 8) Directory #8 – System Restoration
- 9) Directory #9 – Generator Gross/Net Real Power Capability
- 10) Directory #10 – Generator Gross/Net Reactive Power Capability
- 11) Directory #11 – UFLS Program Requirements

The 11 directories developed by NPCC contain regional reliability criteria, which are designed around NERC reliability standards and have applicability to functional entities. Several of the directories also have applicability to BPS facilities. However, the criteria that are specified in each directory are more stringent than what is contained in the NERC reliability standards.

Similar to the NERC reliability standards, the NPCC regional reliability criteria should have requirements that are as, or more, stringent than what is currently being adhered to, such that reliability would be maintained or improved on the IIS. The current operations of NLH will continue with the additional responsibility of ensuring that no aspect of its operation will impact the reliability of the North American BES and in particular for NPCC, northeastern North America. These criteria have been developed by the industry and adopting these criteria would ensure consistency with other jurisdictions in North America. Therefore, it is anticipated that adopting these criteria would maintain and in some cases improve the current level of reliability.

The NPCC bylaws state that “Independent system operators (ISOs), regional transmission organizations (RTOs), Transcos and other organizations or entities that perform the Balancing Authority function operating in Northeastern North America are expected to be Full Members of NPCC (Amended and Restated Bylaws of Northeast Power Coordinating Council, Inc., Amended on January 1, 2012, Page 3) . Full Members are subject to compliance with regionally-specific more stringent reliability criteria for their generation and transmission facilities on which faults or disturbances can have a significant adverse impact outside of the local area and which are identified utilizing a reliability impact based methodology”. A Nalcor affiliate will be performing the Balancing Authority function. However, the extent to which the regional reliability criteria would apply will depend on the results of NPCC BPS testing criteria (NPCC document A10) and discussions with NPCC.

AESI comments on Page 11 of its report that “given that these interconnections are DC links, NL could consider becoming its own Interconnection, similar to Québec and Texas. However, this approach introduces a new level of complexity that requires a separate assessment with respect to implications and costs. While the basic principles of NL establishing a reliability framework that is appropriate for NL still apply in both scenarios, NL as its own Interconnection would suggest additional governance and oversight requirements as a Regional Entity, albeit one appropriate for NL.”

#### **7.4.6 Benefits and Costs from NERC and NPCC Compliance**

In these two studies listed in section 7.4.4, Nalcor has concluded that adopting some or all of the reliability standards would align with its strategic directions and goals. Nalcor has also recognized that there are a number of clear benefits that would be gained by the province if some or all of the reliability standards and the regional reliability criteria were adopted. On a high level basis, Nalcor describes the benefits as follows:

- 1) Nalcor would have a clear, consistent and technically sound set of reliability standards;
- 2) NL would realize a higher level of consistency with other jurisdictions in Canada in terms of reliability practices;
- 3) Compliance measures would ensure reliability is maintained and improved; and
- 4) Membership in NERC and NPCC will enable the shaping of the content and efficiency of the standards to improve reliability.

In order to implement the NERC/NPCC reliability framework in NL, Nalcor has suggested the following major processes could be required:

- 1) A Memorandum of Understanding (MOU) developed between NERC, NPCC, NLH, Nalcor and the PUB, or other appropriate party to be determined<sup>240</sup>

---

<sup>240</sup> The PUB’s role and responsibilities in such areas have not been established, nor has a decision been made that the PUB would have such a role or responsibilities. Depending on the form and scope of any such reliability framework to be adopted, it may also be appropriate for NP to be a party to such an MOU.

## 2) Amendments to the *Public Utilities Act*

The NL Government could directly get involved in these processes or designate its power to the PUB or another entity.

The other component to the reliability framework is a structured program to ensure compliance with the NERC reliability standards and NPCC regional reliability criteria that are adopted. A compliance and enforcement program is very important and was noted as one of the benefits to adopting the standards and criteria. The program would ensure that the reliability of the BES is maintained and improved and that violations are mitigated.

Based on the benefits discussed in the two reports, Nalcor has recommended the following implementations, which may require further assessment by an independent consultant:

- 1) Nalcor adopts some or all of the NERC reliability standards that were determined to be required or optional in the cost assessment report
- 2) Nalcor adopts the NPCC regional reliability criteria and determines the facilities that these criteria would apply to. This would be done through a Bulk Power System (BPS) assessment using NPCC – A-10 and discussions with NPCC
- 3) Nalcor to become a member of NERC and NPCC to ensure maximum benefits are gained from adopting the reliability standards and regional reliability criteria
- 4) Nalcor develops an implementation plan for the NERC reliability standards and NPCC regional reliability criteria
- 5) The provincial government should determine the reliability framework and compliance program for NL. This would include investigating the inclusion of other utilities and entities in the province

In its second report referenced above (Cost Assessment – NERC Reliability Standards and NPCC Regional Reliability Criteria for Nalcor), Nalcor provides detailed cost estimates for Nalcor (including NLH and its other subsidiaries) to adopt the NERC and NPCC standards and criteria. The analysis showed that using 30% for a contingency factor, the range for the total overall cost estimates for the initial setup and first operating year would be from \$5 million to \$6.5 million. This estimate includes both initial costs to get to a compliance level (from \$4 million to \$5.2 million) and ongoing annual costs (in 2012 dollars) to maintain compliance (from \$1 million to \$1.3 million). This cost estimate includes the following three components:

- a) The initial costs to get to compliance and ongoing annual costs to maintain compliance
- b) Initial costs including one-time capital, internal labour and external assistance requirements

- c) Ongoing costs including labour, new staff requirements and NERC/NPCC funding requirements.

AESI has estimated that the total cost would be in the range of \$5.7 million to \$7.5 million and also indicates that a more definitive cost estimate would require “a more thorough and comprehensive gap assessment with the various Nalcor SMEs’ and reviewing any existing documentation, processes, and procedures to see how they map with the requirements of the Non-CIP (FERC Order 693) and CIP v5 (FERC Order 706/791) Standards.” AESI further indicates that “AESI does not think that a detailed gap assessment would identify any increase in the cost that has been identified in this report but could identify opportunities to lower the cost.”

Power Advisory’s opinion is that the estimated cost may be reasonable for the development of initial set-up and the first operating year, but what is missing is the Subject Matter Experts’ opinion and the potential for material changes in the power system infrastructure in the light of the Reliability Framework established for the province. Also, the proposed gap analysis is necessary to move forward in the NERC compliance program.

It is believed that the cost of system studies (SPS, UFLS or UVLS etc.) initially required would be more related to the Labrador-Island Link and Maritime Link projects than adopting the Standard and Criteria. However, there will be annual on-going costs associated with subsequent assessments which could be higher than expected.

As noted above, NERC Reliability Standards are considered to be the industry standard for ensuring the reliability of the BES in North America. At present, NLH does not adhere to NERC Reliability Standards in its planning process. However, with the development of the Labrador-Island Link and Maritime Link projects, Newfoundland and Labrador will be interconnected to the North American Grid. It is, therefore, expected to follow several NERC reliability criteria once it is interconnected with other control areas in NPCC.

As indicated in AESI’s report, “the Interconnection Operating Agreement (IOA) with NSPI places specific reliability obligations on Nalcor, with many of them closely aligned to NERC Reliability Standards.” and “Section 4.1 – *Operational Control* of this IOA agreement, appears to bind both parties to those standards Nova Scotia (NS) must adhere to; that is, those Reliability Standards established by the Standards Authority – NERC and NPCC per the definitions.”

Power Advisory supports AESI’s opinion for adopting the NERC standards with specific tailoring appropriate for the needs of Newfoundland and Labrador and “the key is establishing the specific NL-BES facilities the standards apply to within the reliability framework best suited for NL.”

It is expected that reliability of the Newfoundland and Labrador power system will improve as the transmission system will be stronger with the completion of the planned projects. However, there are a few important points that should be kept in view. They are as follows:

- The Labrador-Island Link project is based on the premise that the existing Holyrood thermal units will be retired. In this way, Muskrat Falls will become a primary source of power to St. John's and its surrounding areas;
- There is one CT at Hardwoods terminal station that is planned to be retired or overhauled by 2026. If Hardwoods and Holyrood thermal generation are retired (one Holyrood unit will remain but as a synchronous condenser and not for generation), generation within the St. John's area after 2026 could be limited to the new combustion Holyrood turbine; and

The security of transmission for the St. John's area will primarily rely on the Labrador-Island Link HVdc and two 230 kV lines from Western Avalon.

The Maritime Link will be capable of carrying power in either direction but change in the direction of flow will not be an automated event. It is understood that mostly power will flow through the Maritime Link from Newfoundland and Labrador to Nova Scotia. The power in-feed through Labrador Island Link would be primarily for the Island during the winter season, contributing up to 50% of the Island load. With the addition of Bay d'Espoir- Western Avalon 230 kV line the reliability of power supply to the Avalon area will be enhanced. The 230 kV network in St John's area will be reconfigured such that there will be two 230 kV lines from Soldiers Pond to Holyrood and Hardwood terminal stations and one 230 kV line to Oxen Pond.

However, an essential requirement is the close coordination between the Labrador Island Link and Maritime Link to respond to contingencies on both the systems. Under export conditions, certain contingencies in the Nova Scotia system may invoke special protection systems (SPS) and require Maritime Link to run-back. Under such contingency conditions, run back would be reflected to Labrador-Island Link through controls and thus would not affect the NLH system.

## **7.5 Failure Modes**

### **7.5.1 Generation Forced Outage Rates**

Unlike other facilities in a power system, generating units experience various states during their operation, such as operating, outage, available but not operating, etc. The CEA (Canadian Electricity Association) publishes annual reports on generation equipment status – Equipment Reliability Information System,<sup>241</sup> which include the definition of various states as well as statistical results of generating units for the recent one year and recent five years.

In generation planning studies the assumptions on the future forced outage rates (FOR) of generating units are important inputs and represent the probability that a specific unit will not be available for service when required. Further details on the definitions for the forced outage rates used in NLH's planning are provided in Appendix G.

---

<sup>241</sup> The latest CEA report is 2013 Generation Equipment Status Annual Report – Equipment Reliability Information System



## **7.6 Coordination**

Being a customer of NLH, NP is dependent on the reliability of electricity supplied by NLH. NP's SCC relies upon NLH's ECC to keep it updated on system demand and availability of generation resources on a timely basis. The energy management system in NLH's ECC is linked to the supervisory control and data acquisition system in Newfoundland Power's SCC. This link provides each utility with near real-time information concerning the other's electrical operations on the IIS. Communication and coordination between NP's SCC and NLH's ECC is continuous and is the central feature of daily operational coordination on the IIS. NP's SCC and NLH's ECC ensure that routine daily electrical system operations such as generation dispatch and line and equipment switching are performed on a safe and reliable basis.

Information flow between NLH and NP is crucial for the reliable operation of the electrical systems during extreme conditions. Normally, providing real-time information on generation-load balance and short term forecast by NLH to NP shall be of no importance as NLH is responsible for dispatch of generation units. However, under abnormal conditions such as those that occurred in January 2014 when there was insufficient generation or transmission capacity available, lack of such information may limit NP's ability to respond timely to system conditions through appeals to its customers to reduce their electricity usage until system conditions improve. However, it is understood that this information exchange between NLH and NP control centres has been enhanced with formal protocols and increased electronic data exchange since January 2014.

Coordination between NLH and NP is essential for daily operation to ensure the one utility's action does not unnecessarily affect the other and their joint actions are such that there is minimum interruption of power to customers. NLH's ECC and NP's SCC play a key role in outage planning and response to electrical system events caused by the system's internal faults or weather etc.

When responding to major electrical system events, NP's SCC and NLH's ECC work together to re-establish normal operations on the electrical system in a controlled and orderly fashion. NLH's ECC operators typically take a lead role in informing NP and guiding its response to major electrical system events via the SCC.

NP's electrical system is programmed so that, whenever system demand or availability of generation requires, customer load will be shed to protect the integrity of the IIS. Following such an event, NLH's ECC coordinates with NP's SCC to ensure that customers disconnected from the system are reconnected to the system quickly while maintaining system integrity.

## **7.7 Service Reliability in Newfoundland and Labrador**

Service quality of an electricity system is assessed and measured based on the reliability of the electricity system to deliver energy to customers. The reliability metrics for Newfoundland and Labrador are defined and discussed in this section. Specifically, the section compares reliability metrics for Newfoundland and Labrador to average values for other Canadian utilities using Canadian Electricity Association (CEA) statistics, the average Forced Outage Rates for equivalent

generating units as reported by NERC participants and internal targets set by the respective electric utility. A wide range of reliability statistics are used, with different statistics employed for generation and transmission/distribution assets. For both it is important to consider the frequency of outages and their duration, since each affects service quality, but in different ways. Statistically significant trends in historical reliability metrics are also identified and discussed for both NLH and NP.

Resource adequacy for an electricity system considers whether the power system has sufficient energy resources and delivery capability to meet demand in a reliable manner. The analysis of resource adequacy uses Loss of Load Expectation (LOLE) or Loss of Load Probability (LOLP) analysis to determine the amount of system capacity required to meet a desired reliability target. LOLE and LOLP are probability assessments that determine the likelihood that available resources will be available to produce power to meet system demand. NERC, the regulatory authority for reliability of bulk power systems (BPS) in North America, employs a LOLE of 0.1 days/year.<sup>242</sup> A drawback of the LOLE metric is that it does not indicate the potential energy shortfall or the potential duration of the outage since it only considers the peak hour of the days that have significant LOLP. An alternative metric which is not commonly used is Loss of Load Hours (LOLH) which considers all hours during which there may be a risk of insufficient generation. With the IIS not connected to the North American grid and therefore not able to rely on imports from neighbouring jurisdictions to provide reserves that reduce the cost of a higher reliability target, NLH is applying the LOLH metric with a target of 2.8 hours/year.<sup>243</sup>

Reliability of transmission and distribution service considers the outage frequency, the number of outages a customer experiences over a year, and outage duration, the total hours of interruption a customer experiences over a year. Interruption of service that results in an outage for a customer can occur from either planned outages (i.e. regular maintenance or equipment replacement) or unplanned outages (i.e. equipment failure or adverse weather impacts).

### **7.7.1 Generation Outage and Availability Measures**

The reliability performance of generation resources is measured and reported in Newfoundland and Labrador using several different reliability parameters. The first parameter is Weighted Capability Factor (WCF) which measures the percentage of time during the year that a generation fleet is available to supply power at its maximum continuous generating capacity (e.g., a WCF of 80% indicates that generators are available at their maximum continuous rating 80% of the year). The factor is weighted to reflect the difference in generator capacity ratings, such that larger units have a greater impact. The second measure, Derating-Adjusted Forced Outage Rate (DAFOR), assesses the probability (the percentage of time) that a generation asset is unable to generate due to forced

---

<sup>242</sup> Methods to Model and Calculate Capacity Contribution of Variable Generation for Resource Adequacy Planning. NERC. March 2011. <http://www.nerc.com/files/ivgtf1-2.pdf>

<sup>243</sup> NLH notes that benchmarking indicates that a LOLH of 2.8 hours/year is equivalent to .2 days/year. (PUB-NLH-056, Island Interconnected System Supply Issues and Power Outages)

outages or deratings, but does not consider outages for scheduled maintenance. While WCF indicates the capability of a generation fleet to produce maximum output as a percentage of the year and DAFOR indicates the unavailability of a generation fleet over a year, both of these reliability parameters can be used to assess the ability of generation resources to produce power on a continuous basis throughout a given year.

Generation reliability can also be assessed based on a number of other metrics that NLH reports to the CEA. These metrics include the following:

- Failure Rate, the frequency a generation unit encounters a forced outage. Failure rate is computed by dividing the number of forced outages by the number of service hours (i.e., hours operating to provide an electricity generation function) in a year.
- Incapability Factor (ICbF), the ratio of Total Equivalent Outage Time, in hours, to the total number of commercial service hours in the period times 100. This is essentially the percentage of hours that the unit is unavailable when the generation unit is in commercial service.
- Utilization Forced Outage Probability (UFOP), the probability that a generating unit will not be available when required.

In addition the NERC Generation Availability Data System (GADS) can be used to compare the Forced Outage Rate (FOR) of NLH generation units against other similar generating units that participate in the GADS.<sup>244</sup> FOR is calculated by dividing the number of forced outage hours by the sum of the service hours and forced outage hours, it provides an indication of the probability that the unit will not be available for service when required.<sup>245</sup>

### 7.7.2 Transmission and Distribution Reliability Measures

There are two common reliability measures for a distribution network: System Average Interruption Duration Index (SAIDI) which is the average outage duration expressed in units of time (e.g., minutes) for each customer served; and System Average Interruption Frequency Index (SAIFI) which is the average outage frequency for each customer served expressed as the number of outages.

$$\text{SAIDI} = \frac{\text{sum of all customer interruption durations}}{\text{total number of customers served}}$$

$$\text{SAIFI} = \frac{\text{total number of customer interruptions}}{\text{total number of customers served}}$$

---

<sup>244</sup> The latest information published by NERC is for the 2007 to 2011 period.

<sup>245</sup> <http://www.nerc.com/docs/pc/gadstf/ieee762tf/762-2006.pdf>

For transmission networks, there are equivalent reliability measures T-SAIDI for outage durations and T-SAIFI for outage frequency. The key difference between distribution SAIDI/SAIFI and T-SAIDI/T-SAIFI is that T-SAIDI/T-SAIFI are measured based on delivery points (i.e. transmission stations) instead of customer connections.

A third measure is Customer Average Interruption Duration Index (CAIDI) which measures the average outage duration expressed in units of time (e.g., hours or minutes) that any given customer would experience. For transmission service CAIDI is also referred to as System Average Restoration Index (SARI) which measures the average restoration duration for transmission interruptions. CAIDI is calculated using the ratio of SAIDI to SAIFI.<sup>246</sup> Reliability statistics are typically tracked for transmission and distribution networks separately to reflect the different planning and design approaches of the two systems and to reflect the respective performance of the two separate elements of the delivery infrastructure.

### **7.7.3 Island Interconnected System: Challenges of Isolated System**

As discussed earlier in Section 7.2.2, the service reliability of the IIS faces two specific challenges given that it is an isolated system that has no interties with neighbouring jurisdictions. Because it is not connected to other electricity systems, the IIS has an increased cost to maintain a higher level of generation reserve compared to other systems that can rely on capacity support from neighbouring jurisdictions to meet LOLE reliability targets. Specifically, interconnected systems can rely on neighboring systems to provide capacity and/or energy support when generation or transmission outages are experienced that threaten system reliability reducing the amount of surplus capacity or generation reserves that are required to ensure the ability to serve customers. For example, Ontario is interconnected to Manitoba, Minnesota, Québec, Michigan and New York. These five neighbouring jurisdictions can support Ontario's bulk power system and local power systems during reliability events or during peak demand periods.

NLH has concluded several times that the cost of maintaining a higher level of generation reserve to meet the typical 0.1 day per year (1 day in 10 years) LOLE reliability target is uneconomic for the IIS.<sup>247</sup> The first analysis by NLH's System Planning Department evaluating the appropriateness of a LOLP index as a measure of system reliability was conducted in 1977.<sup>248</sup> Prior to 1977 NLH employed a short-term reserve criterion that required NLH to be able to supply 95% of the IIS's coincident peak demand with the largest generating unit out of service. The LOLP analysis concluded that LOLP was a reasonable measure of supply adequacy for three reasons:<sup>249</sup>

- LOLP takes into account the difference in reliability of different types of generation resources;

---

<sup>246</sup> SARI is calculated using the ratio of T-SAIDI to T-SAIFI.

<sup>247</sup> PUB-NLH-056. Island Interconnected System Supply Issues and Power Outages.

<sup>248</sup> See Appendix H for a discussion regarding this analysis and the cost of incremental generation reserves.

<sup>249</sup> System Planning Department, Recommended Loss of Load Probability (LOLP) Index for Establishing Generation Reserve Additions (Newfoundland Labrador Hydro: internal memo, May 16, 1977).

- LOLP assumes the daily peak load for every day of the year compared to only the peak load for the year; and
- LOLP incorporates the maintenance of generation units and not just the capability to produce power of the largest generating unit.

In 1997 NLH's System Planning Department migrated to new generation planning software which required NLH to adopt Loss of Load Hours (LOLH) instead of LOLP. NLH analysis concluded a LOLH of 2.8 hours per year is appropriate for the IIS. The LOLH criterion has been reviewed on multiple occasions since its adoption<sup>250,251</sup> and is currently under review by NLH as part of the 2014 outage event investigation.<sup>252</sup> NLH has adopted an interim approach which it will employ until the Labrador-Island Link and Muskrat Falls are in service. Specifically, it will monitor reserves on an ongoing basis and formally assess and report to the PUB any requirement for additional generation on an annual basis in August of each year.<sup>253</sup> NLH's longer-term approach to LOLH post-interconnection will be assessed over the next couple of years.

A second issue that impacts the service reliability of the IIS is Under Frequency Load Shedding events. Electricity systems in North America operate at a frequency of 60 Hz, with the system operated so as to maintain this frequency. Deviations from this frequency can harm equipment at customers' sites. Due to its relatively small size the IIS utilizes under frequency load shedding (i.e., electricity load is removed from the system when the system frequency drops to a certain level) to respond to certain generator/transmission outage events. Frequency stability is a significant issue in small power systems due to low system inertias.<sup>254</sup> Power systems have an inertial reserve where lost power (i.e., sudden generator outages) can be compensated by the energy stored in rotating mass of all remaining generators. Small power systems have low system inertia (i.e., reduced amounts of operating generation) which makes those systems more susceptible to frequency deviations. With a peak demand of about 1,500 MW, the largest generation unit (Holyrood G1 – 170 MW<sup>255</sup>) in the IIS represents roughly 10% of the supply mix during peak demand conditions. During outage events where unit(s) at Holyrood GS trip the system frequency can drop below the minimum of 58.8 Hz, which requires the activation of under frequency protection. Under frequency load shedding can be a disruptive reliability event for two reasons. Load is shed during under frequency disturbances even though enough energy resources are available to meet the system demand. Further, load that has been shed in many instances cannot be

---

<sup>250</sup> Interoffice Memorandum from Ken Hayward to Keith Boone on LOLH Criterion Evaluation. February 2, 1998.

<sup>251</sup> Report on Two Generation Expansion Alternatives for the Island Interconnected Electrical System – Volume 2: Studies January 2012.

<sup>252</sup> PUB-NLH-056. Island Interconnected System Supply Issues and Power Outages. NLH has engaged outside consultant Ventyx to review generation planning practices including review of the criteria used for generation source additions.

<sup>253</sup> See Section 3.1.1 of NLH's Reply Submission to the Liberty Report (February 5, 2015).

<sup>254</sup> Power System Stability on Island Networks. Digsilent GMBH. Prepared for IRENA Workshop. April 2013.

<sup>255</sup> 2014 Planned Generation Outage Schedule. NLH. Provided to Power Advisory as part information request.

re-energized as a single block due to system stability concerns and must instead be brought back online in small increments.

#### 7.7.4 NL Service Reliability Measures

##### 7.7.4.1 Generation

NLH reports its generation related reliability measures (WCF and DAFOR) to the PUB as part of an annual report on Key Performance Indicators (KPIs) and compares these values to the CEA average. The CEA averages are for two separate periods and as a result change in the figure below.

**Figure 40: Weighted Capability Factor (WCF) Performance 2004 to 2013**

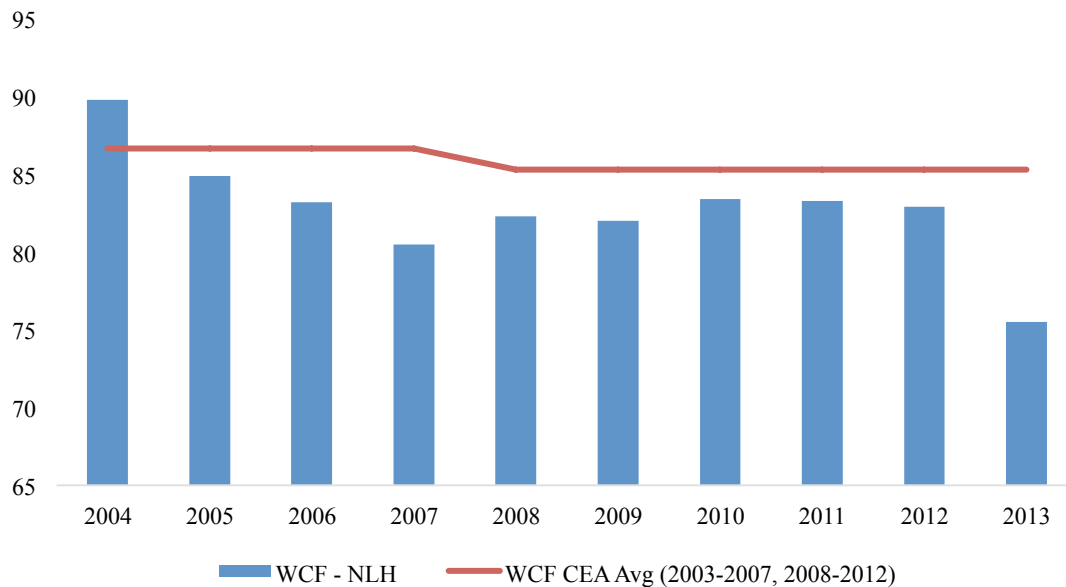

Source: Annual Report on Key Performance Indicators – NLH

The Weighted Capacity Factor (WCF) includes NLH’s thermal, gas turbine, and hydroelectric generation assets on the Island and Labrador Interconnected Systems. In 2013 NLH’s Weighted Capacity Factor was 75.5%, which was below its target of 84%. A major bearing failure at Holyrood GS unit 1 and extended planned outages at Holyrood GS unit 3 were the primary reasons for WCF not achieving the target in 2013. Given higher heating season loads, winter availability is more important than summer availability. The large difference between summer and winter peak demand allows NLH to schedule planned maintenance or capital investment outages outside of the peak demand period of December to March.<sup>256</sup>

<sup>256</sup> In 2014 the peak demand on the IIS was 1,700 MW which roughly 70% higher than the summer peak demand (defined as June to September) of 1,000 MW.

Power Advisory evaluated whether the trend in the reduction of WCF was statistically significant. This analysis indicated that there was a statistically significant reduction in the WCF from 2004 to 2013.<sup>257</sup> NLH was below the CEA average for WCF over the past 5 years, this is due to the performance of Holyrood and the gas turbines as its hydroelectric generating plants had a higher WCF than the CEA average as noted in Table 10 below.

**Table 10: Weighted Capacity Factory Performance**

<b>Weighted Capacity Factory Performance</b>			
	<b>CEA (2008 - 2012)</b>	<b>NLH (2008-2012)</b>	<b>Weighting Factor</b>
Hydro	86.19	92.22	60%
Thermal - Oil Fired	74.38	66.00	31%
Gas Turbine	90.67	70.05	9%

Source: 2013 Annual Report on Key Performance Indicators – NLH

However, with a predominate winter peak, NLH’s practice for scheduling maintenance during the shoulder and summer seasons is typically to minimize cost and to accept a longer outage given that the unit is unlikely to be needed during this period. This adversely affects NLH’s WCF versus most other CEA members.

---

<sup>257</sup> Statistically significant means there is a high level of confidence – specifically, a probability of 95% or more – in the statement or result. For example, a trend is statistically significant if there is at least a 95% probability that an underlying trend exists, and less than a 5% probability that the observed results could have occurred through random chance in the absence of any underlying trend. Different confidence intervals, such as 90% or 99%, are used for different purposes, but for this report, a 95% confidence level is used to determine statistical significance. Statistically significant has this meaning when used throughout the report.

**Figure 41: Weighted DAFOR Performance 2004 to 2013**

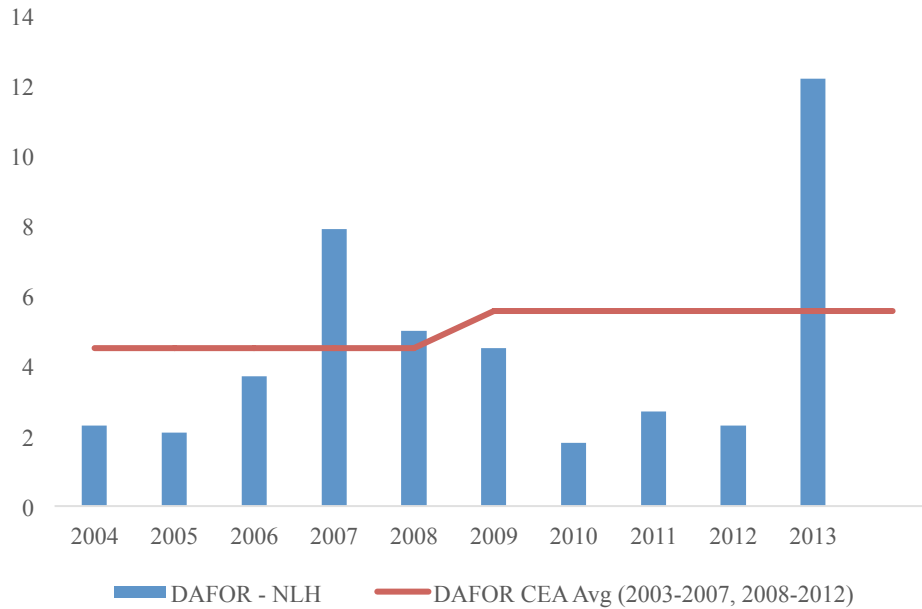

Source: Annual Report on Key Performance Indicators – NLH

The annual percentage of time that NLH thermal and hydroelectric generation assets on the Island and Labrador Interconnected Systems are unable to generate at maximum capacity (i.e., DAFOR) are shown in the Figure above. DAFOR spiked in 2013 to 12.2% due to the forced outage at Holyrood GS from a bearing failure on a turbine in January 2013, significantly exceeding the target of 2.8%. NLH’s DAFOR performance over the past 4 years had been better than the CEA average over the same time period. Hydroelectric generation units have consistently had a high level of reliability performance.

**Table 11: DAFOR Performance**

DAFOR Performance			
	CEA (2008 - 2012)	NLH (2008-2012)	Weighting Factor
Hydro	3.66	1.22	66%
Thermal - Oil Fired	9.33	9.97	34%

Source: 2013 Annual Report on Key Performance Indicators – NLH

NLH participates in the annual reporting of generation unit performance through the CEA. The CEA annual generation equipment report provides statistics for generating units in Canada which



are used by utilities to benchmark generation units and maximize generating unit performance within their financial and logistical constraints. The table below provides the 5-year average (2008-2012) for NLH generation units compared to the CEA data for comparable technology types.<sup>258</sup>

**Table 12: CEA Annual Report Generation Equipment**

CEA Metric Analysis (2008-2012 Avg)	Fuel Type	CEA	NLH
Failure Rate	Hydro	2.06	2.62
	Fossil	7.02	6.38
	Combustion Turbine (CT)	137.89	22.3
Incapability Factor	Hydro	9.33	7.83
	Fossil	25.62	30.99
	CT	13.81	23.12
Utilization Forced Outage Probability	CT	11.84	22.64

Source: CEA

Over the 5-year period from 2008 to 2012 the failure rate for NLH’s hydroelectric generation assets was slightly above the CEA average for hydroelectric generation resources. The Incapability Factor (ICbF) or ratio of total outage time compared to total in-service commercial time for the hydroelectric units over the 5-year period was slightly below the CEA average. The result of these two metrics means that over the 5-year period NLH’s hydroelectric generation units were more likely to encounter a forced outage event during operation but were less likely to be incapable of delivering power to the power system compared to the CEA average over the same time period.

NLH’s fossil generation units from 2008 to 2012 were less likely to experience a forced outage compared to the CEA average but were more likely to be incapable of delivering power to the power system, indicating long average outage times for NLH fossil units. This is likely because these units are needed primarily for the winter peak period and returning them to service outside this period is less important. The NLH’s combustion turbines (CTs) performed well relative to the CEA average with respect to forced outages, but were unavailable more often than the CTs in the CEA survey as indicated by the ICbF and UFOP statistics.

The hydroelectric and fossil fuel (oil) units operated by NLH performed well versus the similar generation units that participate in the NERC GADS during the 5-year period from 2007 to 2011. NLH’s hydro units forced outage rate (FOR) was below that for all hydroelectric generation units (any size) and hydroelectric generation units greater than 30 MW. For fossil (oil) generation units, NLH’s Holyrood units had a FOR above comparable sized generating units and below the average for all unit sizes. See table below for further details on FOR from the NERC GADS.

<sup>258</sup> The 2008-2012 period obviously excludes 2013, when outages at Holyrood and various CTs adversely affected the availability of NLH’s generation fleet.

**Table 13: NERC GADS - Forced Outage Rate (FOR)**

NERC GADS Forced Outage Rate (2007-2011)		FOR
Hydro	NERC GADs - All MW Sizes	3.67
	NERC GADs - +30 MW	3.6
	NLH	0.67
Fossil – Oil	NERC GADs - All MW Sizes	16.64
	NERC GADs - 100 MW - 199 MW	7.19
	NLH	13.5

Source: NERC and NLH

#### **7.7.4.2 Transmission**

Service reliability for the transmission system is measured by NLH by tracking three reliability indices: average annual outage duration (T-SAIDI), average outage frequency (T-SAIFI), and average restoration duration (T-SARI). The reliability measures<sup>259</sup> are provided to the PUB as part of an annual report on KPIs and include comparable results from the CEA utility average. NLH also tracks under frequency load shedding but has no comparable data from CEA as it is a unique measure for the IIS.

---

<sup>259</sup> NLH reliability measures are based on 54 delivery points in IIS and 2 delivery points in LIS. The calculations consider NP as a customer and therefore does not consider customers served by NP further downstream in the electricity system.

**Figure 42: Outage Duration (T-SAIDI) Forced & Planned Outages**

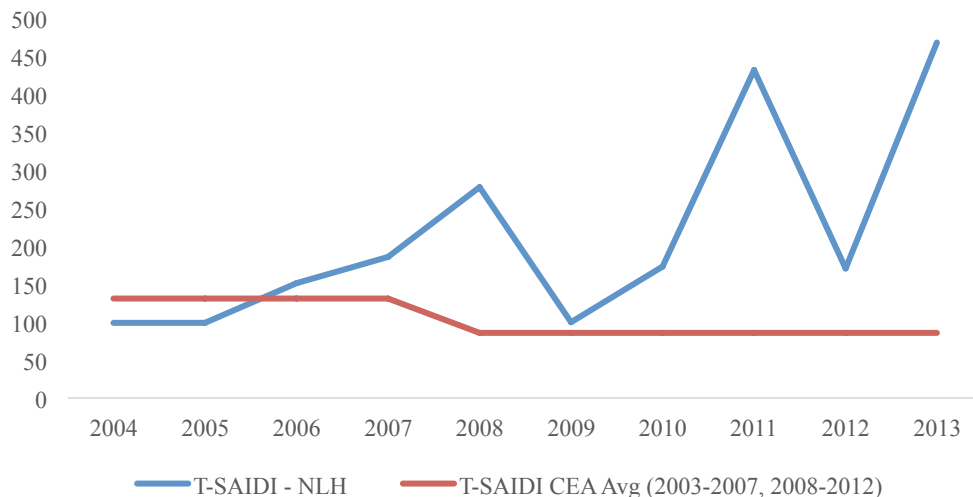

Source: Annual Report on Key Performance Indicators - NLH

The sharp increases in T-SAIDI in 2008, 2011 and 2013 were all related to spikes in outage durations on the 66 kV transmission network. The 66 kV transmission network represents over 40% of the delivery points<sup>260</sup> in the NLH bulk transmission system and primarily supplies remote communities on radial lines. Power Advisory analysis indicated that there was a statistically significant increase in outage durations in NLH’s transmission system (T-SAIDI) from 2004 to 2013. However, this analysis did not attempt to factor out severe weather. NLH also notes that planned transmission delivery point outage durations on the IIS have been higher than forced-outage durations.

**Figure 43: Total Outage Duration (minutes) from 2009 to 2013 by Voltage Class**

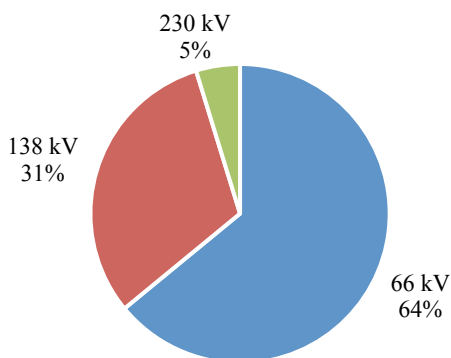

Source: NLH

<sup>260</sup> In 2013 there were 24 delivery points on the 66 kV transmission network out of the total 58 delivery points in the NLH bulk transmission system. That ratio is relatively unchanged from 2004 when there 23 delivery points on the 66 kV transmission network out of a total of 56.

Low voltage transmission circuits such as the 66 kV transmission network typically supply delivery points as a single transmission circuit<sup>261</sup> which does not allow NLH to provide an alternative supply while resolving the outage event. This results in longer outage times as NLH works to repair the system condition. Adverse weather conditions such as winter storms and high winds can aggravate restoration efforts and result in long outage durations such as those experienced by NLH in 2011 and 2013.

**Figure 44: NLH T-SAIDI by Interconnected System**

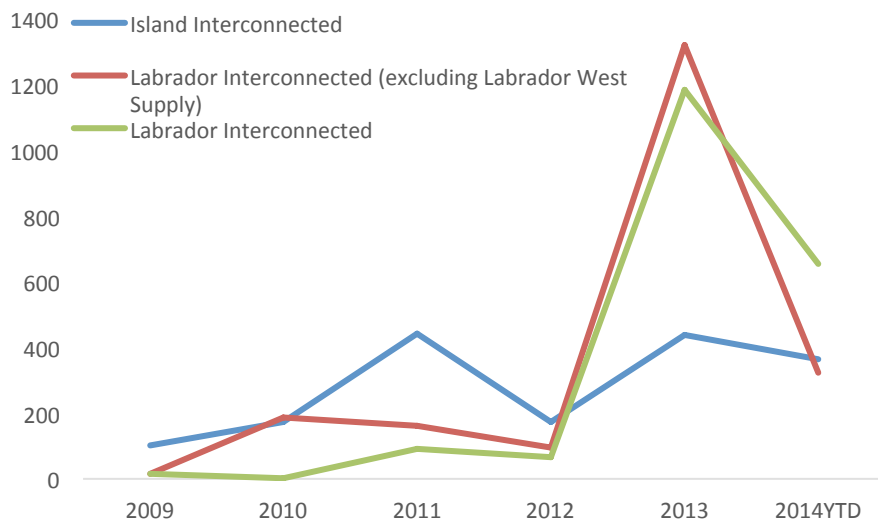

Source: NLH

The outage duration for NLH’s transmission network has increased for both the IIS and LIS over the 5-year period from 2009 to 2014. Except for 2013, the LIS has had similar or lower T-SAIDI compared to T-SAIDI in the IIS.<sup>262</sup>

<sup>261</sup> Single transmission circuits are an individual line supplying a connection point. When an outage occurs on a single transmission circuit the supply to the connection point is severed. A double transmission circuit has two lines that can supply a connection point. If one of the lines is severed during an outage event the connection point can continue to be supplied by the second line.

<sup>262</sup> The LIS has only two delivery points which influences the T-SAIDI values. Since T-SAIDI is the average outage duration across all delivery points, a transmission system with a small number of delivery point will experience large spikes in T-SAIDI. A transmission system with a small number of delivery points will be impacted significantly by long duration outages since unlike a transmission system with large number of delivery points, the small transmission system cannot spread the outage duration across many delivery points. In 2013, the total duration of outages in the LIS was under 2,700 minutes compared to over 30,000 minutes in the IIS. The IIS could spread the outage duration over 56 delivery points while the LIS could only spread the outage duration over 2 delivery points.

**Figure 45: T-SAIFI Forced & Planned Outages**

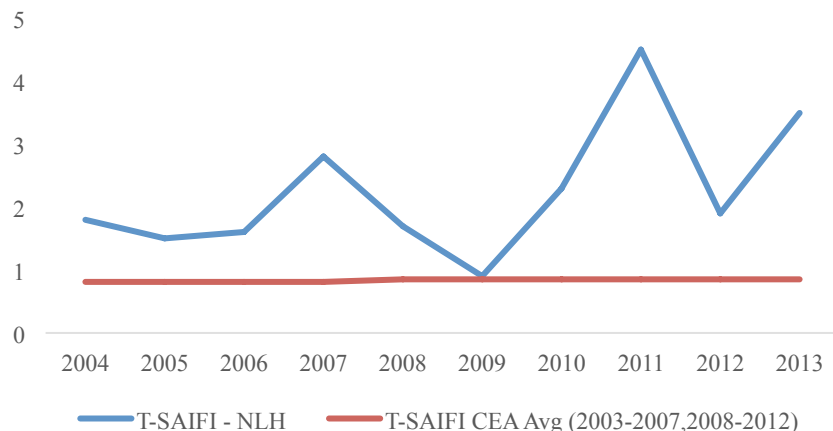

Source: Annual Report on Key Performance Indicators - NLH

NLH has consistently over the past 10 years exceeded the CEA average for average outage frequency on the transmission system (T-SAIFI). Single transmission lines that supply a high number of bulk delivery points has increased the frequency of outages for NLH. For example, on the Great Northern Peninsula one line supplies up to nine delivery points; the loss of this transmission line can result in service interruptions for all nine delivery points. A single transmission line leaves those bulk delivery points with no alternative supply source should an unexpected or planned outage occur on the transmission line. The small system size and low load density across the Newfoundland and Labrador system makes justifying investment in secondary supply difficult. Trend analysis by Power Advisory indicates a statistically significant increase in average outage frequency (T-SAIFI) from 2004 to 2013.

**Figure 46: NLH T-SAIFI Interconnected Systems**

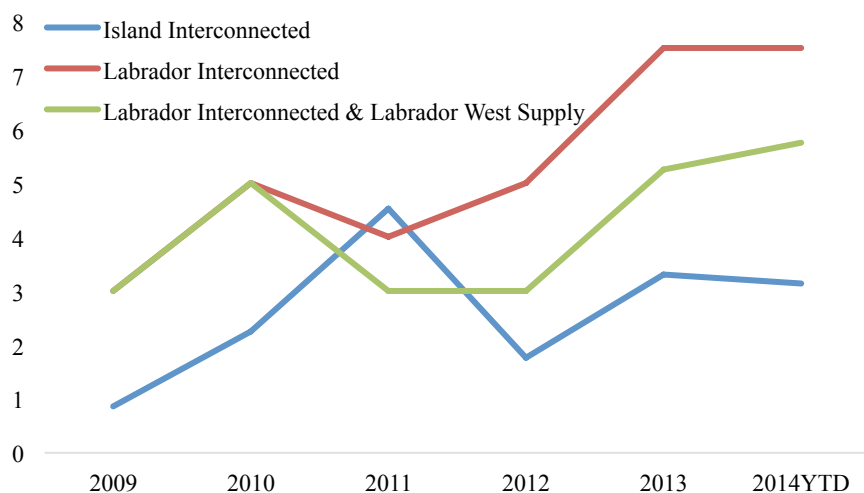

Source: NLH

LIS has a long (250+ km) radial feed line supplying one delivery point and any forced or planned outage on that line would result in an interruption for the delivery point. This single line situation has resulted in the LIS having an average outage frequency higher than IIS in 4 of the past 5 years.

**Figure 47: Number of Interruptions by CEA Cause Code from 2009 to 2013**

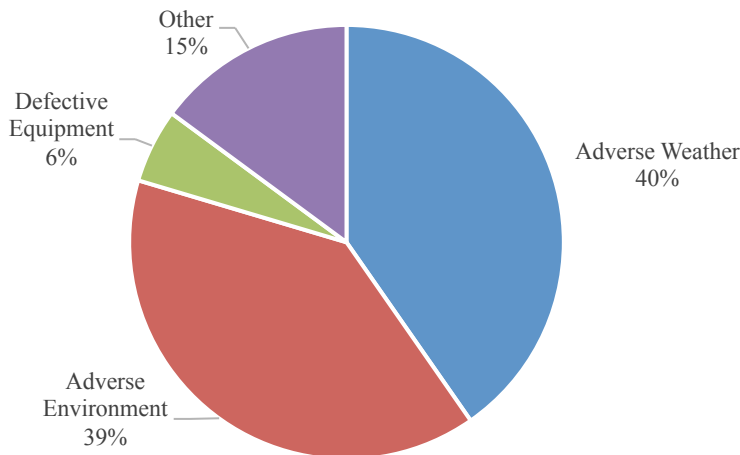

Source: NLH

Adverse weather (including adverse environment) represented 79% of all interruptions in 2013.<sup>263</sup> Lightning, snow and high winds were the primary causes of the increase in adverse weather events. With climate change expected to increase the frequency and intensity of extreme weather,<sup>264</sup> adverse weather will likely continue to be a primary cause of outages. This may require NLH to invest in reliability measures to increase the resilience of their electricity system to withstand these extreme weather events.<sup>265</sup>

NLH’s 2013 transmission average restoration duration (T-SARI) target was 122 minutes per delivery point, which was exceeded once (in 2011) over the last 5 years. While NLH has exceeded the CEA average for average outage duration (T-SAIDI) and average outage frequency (T-SAIFI) over the past 5 years, they have been able to remain near the CEA average for outage restoration duration (T-SARI) in that time period. This indicates that although NLH has experienced an increase in outages, the average restoration time to those outages on a per outage basis is in line

<sup>263</sup> Adverse Weather as defined by the CEA includes outages caused by lightning, freezing rain, ice, snow and wind among other weather events. Adverse environment by comparison are primarily human activity driven outages including salt spray, industrial pollution and vibration.

<sup>264</sup> Canada in a Changing Climate: Sector Perspectives on Impacts and Adaptation. Natural Resources Canada, 2014.

<sup>265</sup> This would require NLH to identify the weak components of their transmission system are vis-à-vis adverse weather events and determine what investment options are available to strengthen those components. For example, lightning arresters may be required to reduce lighting outage events and the total cost of installation will need to be compared to alternatives such as secondary supply capability.

with other utilities across Canada. Average restoration duration has increased from 2004 to 2013 according to trend analysis by Power Advisory.

**Figure 48: T-SARI Forced & Planned Outages**

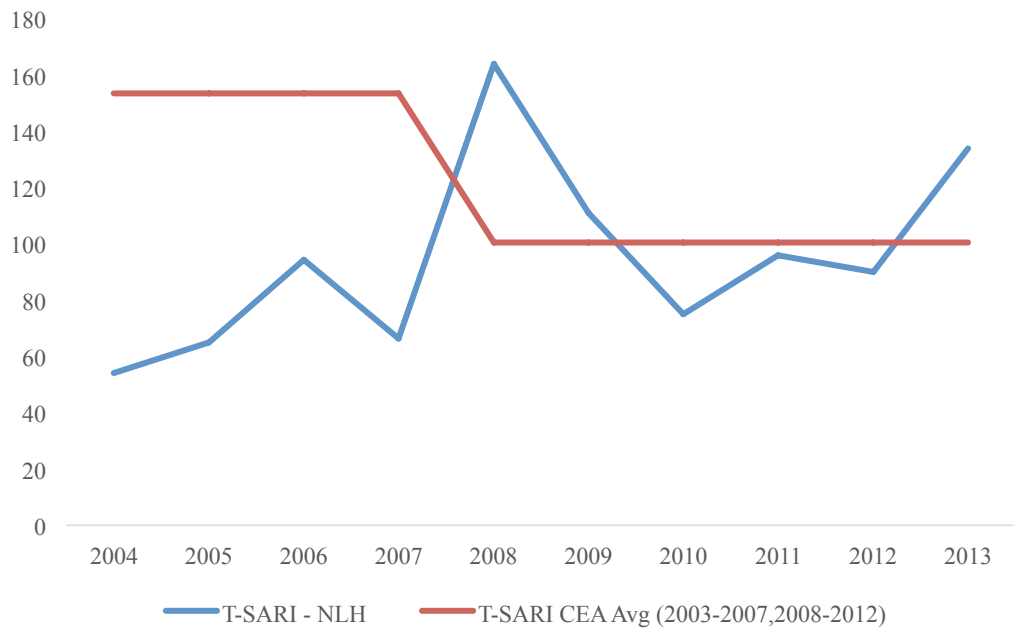

Source: Annual Report on Key Performance Indicators - NLH

**Figure 49: Under Frequency Load Shedding Events**

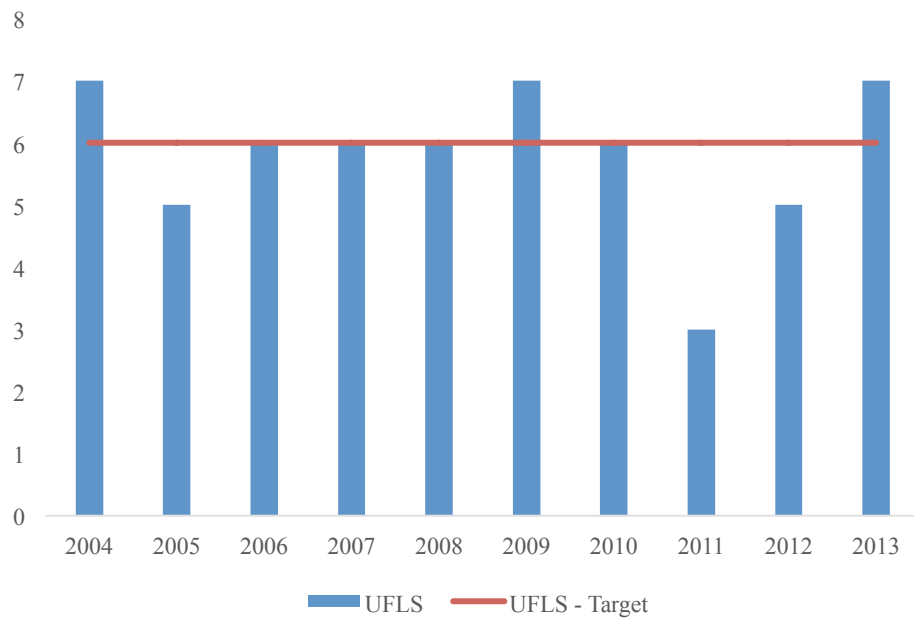

Source: Annual Report on Key Performance Indicators – NLH

Under frequency load shedding (UFLS) events which require NLH to force an outage on customers or delivery points to maintain transmission system stability increased to 7 for 2013 and exceeded the target of 6; 2013 was the highest level of UFLS since 2009. Of the 7 events in 2013 four were triggered by faults at Holyrood GS and three were triggered by faults at Bay d’Espoir GS. Malfunction of equipment at both sites was the primary cause of 5 of the 7 UFLS events.

Both the Holyrood and Bay d’Espoir generation facilities represent a significant portion of the supply capacity available to the IIS and outages at either site can trigger UFLS as the system does not have enough internal inertia to respond to the lost output from these units. The Labrador-Island Link should allow NLH to avoid UFLS events in most circumstances as the HVDC converter station’s reaction time is significantly better than generators.

As shown below, UFLS events impact NP the most given that it serves the majority of load on the IIS.

**Table 14: Under Frequency Load Shedding Unsupplied Energy (MW-min)**

Customer s	Year to Date		5-Year Average (2009-2013)
	2012	2013	
NP	13,917	3,194	3,854
Industrials	0	140	115
Hydro Rural	324	107	95
Total	14,241	3,441	4,064

Source: 2013 Annual Report on Key Performance Indicators – NLH

#### **7.7.4.3 Distribution**

Similar to the transmission systems, distribution service reliability performance is measured by three different reliability indices: average annual outage duration (SAIDI), average outage frequency (SAIFI), and average duration per outage (CAIDI). The distribution customers in Newfoundland and Labrador are served by both NLH, which serves more remote areas and would be expected to have a lower service reliability, and NP, with results presented separately.



**Figure 50: NLH D-SAIDI**

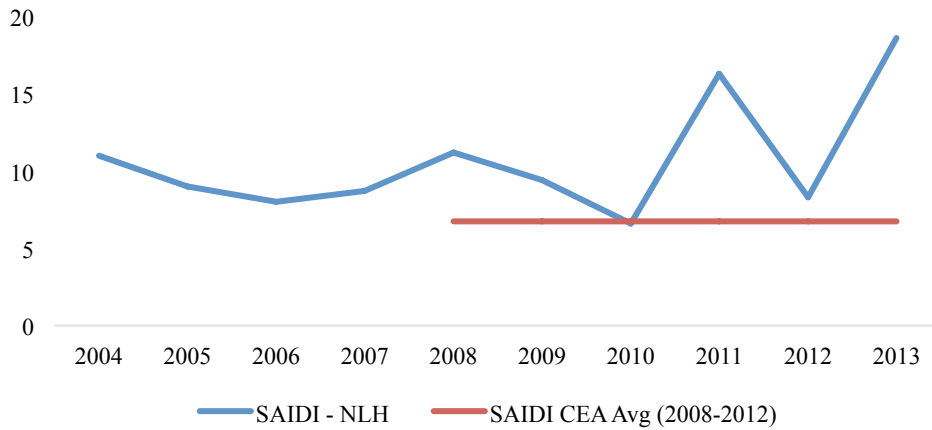

Source: Annual Report on Key Performance Indicators – NLH

From 2008 to 2012 NLH’s distribution system has exceeded the 5-year CEA average<sup>266</sup> for SAIDI. Trend analysis by Power Advisory indicates a statistically significant increase in average annual outage durations (SAIDI) from 2004 to 2013. The primary reason for the increase in outage durations is loss of supply (i.e. transmission outages), planned outages, defective equipment and adverse weather. The spike in 2011 was due to severe storms that caused prolonged outages on the distribution and transmission systems.

**Figure 51: NLH Distribution Customer Minutes of Interruption**

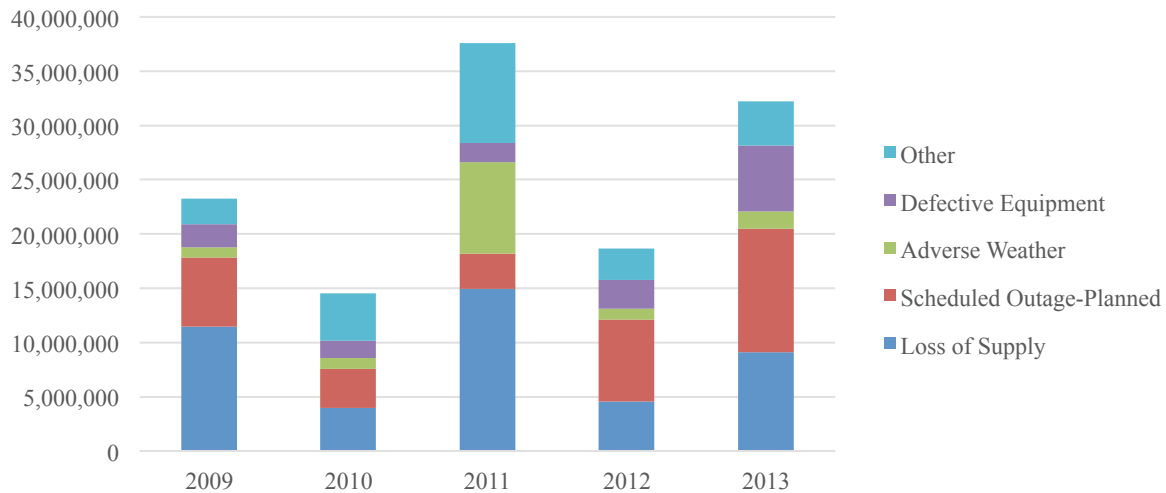

Source: NLH

<sup>266</sup> Average CEA values for SAIDI and SAIFI were not available for the 2003-2007 period.

**Figure 52: NLH SAIFI**

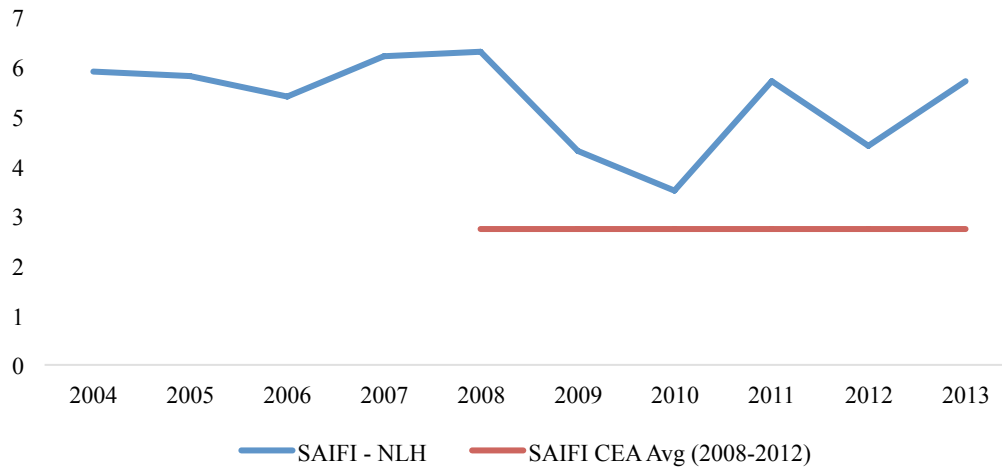

Source: Annual Report on Key Performance Indicators – NLH

Power Advisory analysis indicates that the average outage frequency (SAIFI) for NLH has decreased in a statistically significant trend from 2004 to 2013. During the period of 2009 to 2013 almost 80% of customer interruptions were caused by loss of supply, defective equipment and planned outages. Aging infrastructure may be contributing to the increase in the outages attributable to these three events. Critical equipment that has reached its end-of-life can fail and result in defective equipment caused outages along with the need for planned outages to replace the critical equipment.

**Figure 53: NLH Distribution Customer Interruption from 2009 to 2013**

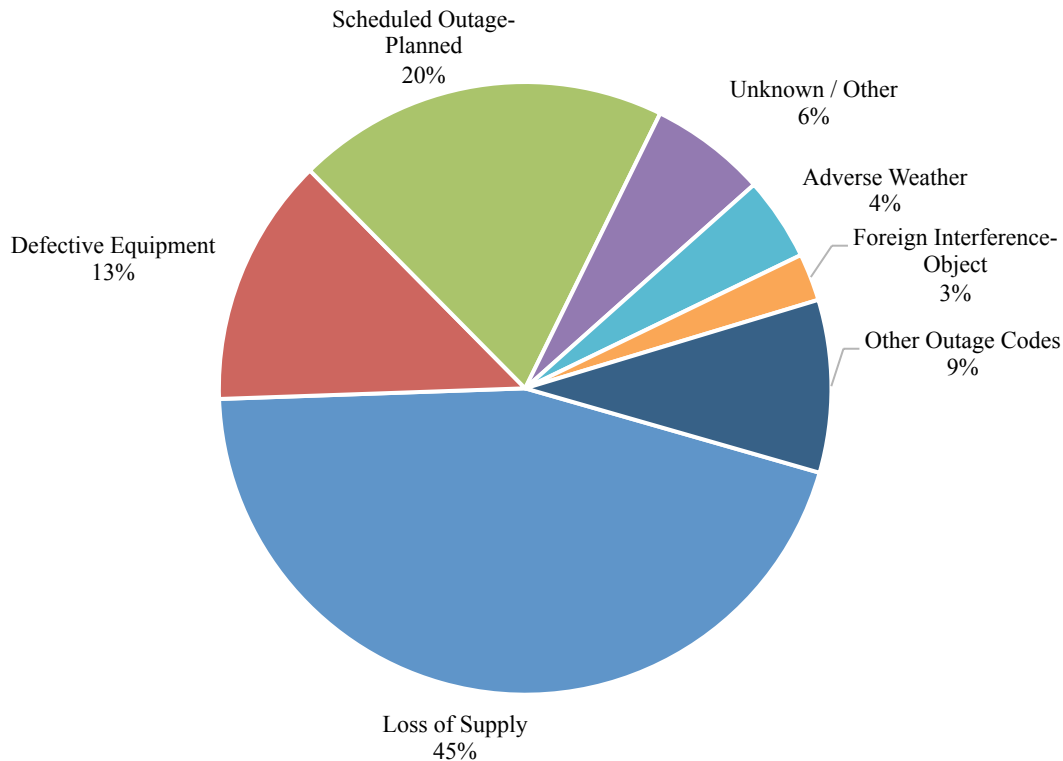

Source: NLH

NP provides only distribution service in Newfoundland according to the CEA definition of a distribution system<sup>267</sup> and therefore NP has no official reliability metrics to report for transmission network services. NP has provided reliability metrics for three self-defined sub-categories within their distribution system to provide greater visibility on their distribution system reliability outside of the CEA definitions. The sub-categories used by NP are: transmission representing all equipment operating at a voltage above 25kV; distribution representing all equipment operating at a voltage under 25kV; and substation for all equipment located within the physical substation site fence. The PCB Phaseout category is for outages pertaining to amendments made to the Environmental Act in 2008 which implemented PCB Regulations to restrict PCB levels in electrical equipment. The PCB Phase Out program implemented by NP ended in 2014 and therefore no

<sup>267</sup> CEA defines a distribution system as that portion of an electric power system which links the Bulk Electricity System (BES) or sources with the customer's facilities. Sub-transmission lines, distribution substations, primary feeders, distribution transformers, secondary and customers' services all form different parts of what can generally be called the distribution system. The Delivery Point (DP) is the delineation point between the BES and the distribution system. More specifically it is the low voltage busbar of the step down transformer station, whereby the transformer busbar is considered part of the BES.

further outages are expected. Loss of Supply outage events are interruptions experienced by NP's customers from supply outages, planned or unplanned, on NLH's system.<sup>268</sup>

**Table 15: NP SAIDI Normal Operations and Significant Events**

	SAIDI						
	Normal Operations			Significant Events	PCB Phaseout	Loss of Supply	Total
	Distribution	Transmission	Substations				
<b>2004</b>	3.25	1.12	0.18	0	0	0.31	<b>4.86</b>
<b>2005</b>	2.56	0.5	0.21	0	0	0.26	<b>3.53</b>
<b>2006</b>	2.22	0.58	0.09	0	0	0.09	<b>2.98</b>
<b>2007</b>	2.22	0.4	0.02	3.29	0	0.53	<b>6.46</b>
<b>2008</b>	2.06	0.51	0.11	0	0	0.12	<b>2.8</b>
<b>2009</b>	2.12	0.34	0.11	0	0	0.12	<b>2.69</b>
<b>2010</b>	2	0.46	0.13	11.23	0	0.4	<b>14.22</b>
<b>2011</b>	1.89	0.54	0.14	1.26	0.2	0.06	<b>4.09</b>
<b>2012</b>	2.14	0.19	0.11	3.11	0.3	0.89	<b>6.74</b>
<b>2013</b>	1.9	0.18	0.15	0.81	0.22	7	<b>10.26</b>

Source: Newfoundland Power

Average annual outage duration (SAIDI) results for the NP controlled distribution assets have decreased over the past 10 years for their distribution and transmission systems and substations.<sup>269</sup> Power Advisory evaluated whether the trend in the reduction of SAIDI excluding Loss of Supply and Significant Events was statistically significant for any of these operating elements. The analysis of normal operations (i.e., excluding significant outage events) indicated that there was a statistically significant reduction in SAIDI from 2004 to 2013 for NP. The occurrence of Loss of Supply events have increased over the past 10 years in line with NLH's transmission average outage duration (T-SAIDI) trend and the related cause of increase in adverse weather conditions. SAIDI for the NP system including all interruption categories has trended upwards from 2004 to 2013.

<sup>268</sup> CEA defines Loss of Supply as Customer interruptions due to problems in the bulk electricity supply system such as underfrequency load shedding, transmission system transients, or system frequency excursions. During a rotating load shedding cycle, the duration is the total outage time until normal operating conditions resume, while the number of customers affected is the average number of customers interrupted per rotating cycle.

<sup>269</sup> For the purpose of reporting to CEA, all of NP facilities are considered part of the distribution system. The classification of statistics by distribution and transmission was determined by breaking NP's distribution system into components with the delineation point being the substation fence. That is everything inside a substation fence is considered to be substation related, everything outside the substation fence is either transmission or distribution depending on voltage level. Everything operating at 25kv or less is considered to be distribution.

**Table 16: NP SAIFI Normal Operations and Significant Events**

	SAIFI						
	Normal Operations			Significant Events	PCB Phaseout	Loss of Supply	Total
	Distribution	Transmission	Substations				
<b>2004</b>	2.2	0.78	0.12	0	0	0.48	<b>3.58</b>
<b>2005</b>	1.79	0.66	0.12	0	0	0.64	<b>3.21</b>
<b>2006</b>	1.77	0.8	0.09	0	0	0.25	<b>2.91</b>
<b>2007</b>	1.61	0.48	0.02	0.35	0	0.84	<b>3.3</b>
<b>2008</b>	1.62	0.64	0.1	0	0	0.48	<b>2.84</b>
<b>2009</b>	1.23	0.51	0.24	0	0	0.48	<b>2.46</b>
<b>2010</b>	0.91	0.36	0.25	1.17	0	0.3	<b>2.99</b>
<b>2011</b>	1.24	0.28	0.18	0.25	0.07	0.14	<b>2.16</b>
<b>2012</b>	1.34	0.22	0.16	0.4	0.13	0.76	<b>3.01</b>
<b>2013</b>	1.33	0.22	0.16	0.32	0.21	1.59	<b>3.83</b>

Source: Newfoundland Power

NP controlled distribution assets average outage frequency (SAIFI) has improved over the past 10 years with trend analysis completed by Power Advisory indicating a statistically significant decrease. During the same period, trend analysis indicates a statistically significant increase in Significant Events, and Loss of Supply which has offset the decreases in NP controlled distribution assets. Adverse weather and adverse environment are the likely causes, with the impact to NLH's transmission system.

**Table 17: NP SAIFI by Cause**

Normal Operations	2009	2010	2011	2012	2013
Animals	0.01	0.00	0.01	0.01	0.00
Birds	0.01	0.07	0.03	0.03	0.03
Damages Outside Party	0.06	0.07	0.04	0.05	0.01
Employee Operating Error	0.03	0.02	0.04	0.03	0.01
Equipment Failure	0.61	0.50	0.60	0.61	0.63
Fire	0.03	0.03	0.02	0.03	0.03
Flooding	0.00	0.00	0.00	0.00	0.00
Generating Plant or System Problems	0.18	0.05	0.03	0.14	0.06

Improperly Installed Equipment	0.00	0.00	0.00	0.00	0.00
Lightning	0.12	0.07	0.02	0.09	0.08
NLH System Problems	0.32	0.10	0.07	0.69	1.43
NP System Problems	0.03	0.02	0.12	0.05	0.04
Other	0.06	0.02	0.12	0.00	0.02
Overloaded Equipment	0.02	0.01	0.02	0.00	0.02
Plant Upgrades	0.21	0.18	0.15	0.17	0.08
Preventative Maintenance or Repair	0.23	0.25	0.16	0.14	0.15
Salt Spray	0.00	0.01	0.03	0.01	0.01
Sleet	0.09	0.02	0.02	0.02	0.01
Snow	0.03	0.01	0.04	0.03	0.05
Trees in Line	0.10	0.10	0.10	0.09	0.08
Under Frequency	0.15	0.09	0.07	0.07	0.35
Underground Dig In	0.00	0.00	0.00	0.00	0.00
Unexplained	0.05	0.08	0.08	0.06	0.07
Vandalism	0.00	0.00	0.40	0.00	0.00
Vehicles Causing Damage	0.00	0.00	0.01	0.05	0.04
Water in Equipment or Vaults	0.00	0.00	0.00	0.00	0.00
Wind	0.12	0.12	0.12	0.08	0.12

Source: Newfoundland Power

Consistently over the past 5 years, equipment failure has been one of the largest contributing causes for customer interruptions for NP. NLH system problems that impact NP distribution service in the past 2 years have increased dramatically, representing over 40% of total causes. While this is not surprising given the unique outage events experienced by NLH, it certainly suggests that the most critical issue for service reliability for NP customers is the reliability of NLH supply. This assessment is supported by the observation in the Liberty Interim Report that “in both cases [the

2013 and 2014 outage events], the origins of the outages while affected by external conditions (snow and cold weather), lie with Hydro’s generation and transmission systems.<sup>270</sup> On March 4, 2015, about 82,000 customers on the IIS representing about 450 MW of load had service interrupted as a result of a low voltage event attributable to a series of generator outages on the Avalon Peninsula and transmission constraints. The PUB has subsequently opened an investigation into the outage.

While it is natural to seek to compare the reliability performance of NLH and NP comparing these two systems is difficult given significant differences in the composition of the two systems. In particular, the NLH distribution system is inherently more remote and typically served by relatively fewer feeders, making outages by anyone element more problematic.

**Table 18: NP CAIDI by Cause**

<b>Normal Operations</b>	<b>2009</b>	<b>2010</b>	<b>2011</b>	<b>2012</b>	<b>2013</b>
Animals	1.45	2.56	0.59	1.26	1.60
Birds	1.42	0.85	1.46	1.45	1.19
Damages Outside Party	1.97	2.41	1.82	1.58	4.25
Employee Operating Error	0.14	0.03	0.28	0.55	0.23
Equipment Failure	1.79	1.66	1.87	1.55	1.35
Fire	1.06	0.77	0.96	1.22	2.91
Flooding	0.00	1.50	0.00	0.00	0.00
Generating Plant or System Problems	0.25	0.82	1.69	1.14	0.80
Improperly Installed Equipment	1.20	1.94	2.91	1.73	0.64
Lightning	0.51	1.45	0.49	2.15	1.15
NLH System Problems	0.34	2.71	0.71	1.27	4.69
NP System Problems	0.43	0.39	0.90	0.64	2.00
Other	1.10	5.30	1.47	1.87	2.00
Overloaded Equipment	1.05	0.49	2.02	1.67	4.58

<sup>270</sup> Interim Report, p. 3.

Plant Upgrades	1.48	2.33	1.73	0.47	1.88
Preventative Maintenance or Repair	0.80	1.51	1.31	1.64	1.20
Salt Spray	2.72	2.01	0.51	3.64	11.13
Sleet	1.29	2.50	3.63	2.53	4.43
Snow	2.17	1.93	0.90	1.93	1.20
Trees in Line	2.05	1.90	1.20	1.31	1.13
Under Frequency	0.05	0.05	0.09	0.11	0.88
Underground Dig In	0.00	0.00	0.00	0.00	0.00
Unexplained	0.64	0.63	1.34	0.94	1.14
Vandalism	0.10	0.00	1.46	0.00	1.50
Vehicles Causing Damage	8.88	4.36	1.50	1.38	0.71
Water in Equipment or Vaults	0.00	0.00	0.00	2.42	0.00
Wind	1.29	1.92	1.00	1.88	1.08

Source: Newfoundland Power

Salt spray and sleet are the largest contributors to customer interruption durations in the past three years for NP while overloaded equipment and NLH system problems increased significantly in 2013.

### 7.7.5 Comparison of Distribution Service Reliability

NP has been able to reduce average annual outage duration (SAIDI) and average outage frequency (SAIFI) from 2004 to 2013 for the distribution system it controls. Over that same time period, average annual outage duration (SAIDI) for NLH's distribution system has increased. Loss of Supply for NP has increased for both average outage duration (SAIDI) and average outage frequency (SAIFI) over the 10 year time period. With pronounced spikes in SAIDI in 2011 and 2013, the underlying statistical trend is increasing over the last 10 years. Reflecting the remoteness of its distribution systems and lower customer density, the average outage frequency (SAIFI) for NLH customers has exceeded that for NP every year from 2004 to 2013.



**Figure 54: Comparison of Reliability Indices for NLH and NP**

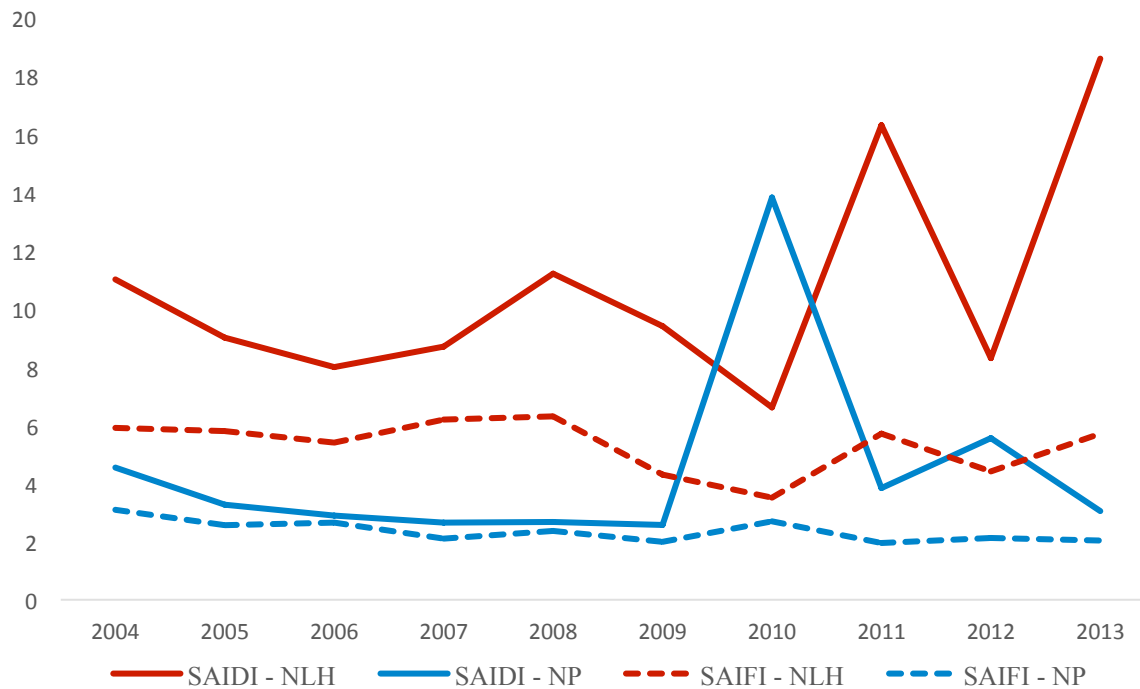

Source: NLH and NP

There are many reasons for the differences between the average annual outage duration (SAIDI) and average outage frequency (SAIFI) statistics for the utilities.<sup>271</sup> In particular, there are significant differences between the two service territories, with NLH’s system considerably more remote, such that response times will invariably be longer. To provide service to these remote areas economically, in many instances NLH utilizes only a single radial line for a delivery point. The absence of redundancy in single radial lines compared to double lines or looped<sup>272</sup> lines results in worse reliability as an outage on any section of the line will impact any delivery point further down the line. A radial line in these instances can be a cost-effective alternative since it requires only the construction of a single transmission circuit to each delivery point; however, there are reliability impacts from such a delivery infrastructure.

### 7.7.6 Summary and Conclusions Regarding Service Reliability

NLH’s hydro generation units performed well over the 2008-2012 period when compared to the CEA averages for a variety of generation metrics. Holyrood has also performed near the CEA average from 2008 to 2012 compared to similar oil units that participate in the CEA survey.

<sup>271</sup> The definition and use of significant outage events when determining outage causes and classification may also impact the reliability results.

<sup>272</sup> A looped line is a single line that is connected to the electricity network at either end. The looped line can provide service to a delivery point from one direction or another allowing a fault to be isolated for restoration repair without the delivery point having to experience a prolonged outage.

Compared to NERC GADS FOR statistics, NLH hydro and oil units have performed better than the average over the 5-year period from 2007 to 2011. The same five-year period excludes 2013 when units at Holyrood and at various CTs had low unit availabilities.

NLH transmission reliability has experienced a statistically significant decrease over the past 10 years with a major contributing factor the increase in extreme weather events. The increased likelihood of such events may force the need for investment to ensure the transmission system can better withstand adverse weather conditions in the future. NLH has exceeded both CEA average outage frequency (T-SAIFI) and annual average outage duration (T-SAIDI) from 2008 to 2012.

The distribution service reliability for both frequency of outages and duration of outages in NP's service territory has improved over the 10 year period of 2004 to 2013. During the same time period NLH's duration of outages has increased. Continued monitoring is appropriate to assess whether investment or action is required to address the trend.

## 8. Load Forecasting

NLH's demand forecasting methodologies have undergone considerable scrutiny in the last several years. Manitoba Hydro International (MHI) reviewed the demand forecast as part of the review of the Muskrat Falls project before the PUB.<sup>273</sup> Since the January 2014 outages NLH has performed an internal review and engaged Ventyx, the provider of its short-term forecasting tool, Nostradamus, to conduct a review and Liberty also reviewed these forecasting methods. In addition in October 31, 2014, NLH submitted a *Progress Report on Load Forecasting Improvements to the Board*. This was in response to the PUB's request that NLH file a report by October 31, 2014 in relation to the changes it has made to its short-term forecasting process and its approach to incorporating sensitivity analyses in its planning. Assessing the impacts of energy efficiency initiatives is one of the key inputs to the load forecast.

### 8.1 Energy Efficiency

NLH and NP (Utilities) planning and analysis of DSM programs is performed on a consolidated basis. The Utilities first jointly offered energy conservation programs to customers in 2009, with the launch of the *Five-Year Energy Conservation Plan: 2008-2013 (the 2008 Plan)*. Forecast savings from the 2012-2016 plan are 317 GWh through 2015, which represents almost 2.8% of total energy requirements on the various Newfoundland and Labrador electricity systems,<sup>274</sup> which is relatively modest relative to many other Canadian electricity systems (e.g., BC, Manitoba, New Brunswick, Nova Scotia, and Ontario). For example, both Ontario and Nova Scotia claim that conservation currently provides about 5% of customers' energy requirements and the budgets in these provinces for these programs are proportionately much higher than those in NL.<sup>275</sup> However, these higher budgets come at a cost: higher rates, but potentially with lower overall bills, particularly for participating customers.

The primary objective of the Utilities' joint residential programs has been to reduce space heating energy consumption and by so doing reduce peak demand given the significant role that electric heat plays in terms of peak load. The programs provide rebates and financing for: (i) ENERGY STAR windows, (ii) insulation, (iii) high performance thermostats, and (iv) heat recovery ventilators (HRVs). These are bundled together for marketing purposes as the *takeCHARGE* Energy Savers. Eligibility is limited to electrically-heated homes and depends on annual kWh usage. Both new home construction and renovation projects have been eligible for rebates.<sup>276</sup>

Historically, the Utilities' program designs have been driven by the high avoided fuel costs at Holyrood (which approached 14 to 15 cents/kWh), the operation of which in turn was driven in

---

<sup>273</sup> Report on Two Generation Expansion Alternatives for the Island Interconnected Electrical System, Volume 2: Studies, January 2012.

<sup>274</sup> September 1, 2015 Email from Nalcor. NLH estimates that the actual savings realized are approximately 300 GWh.

<sup>275</sup> *Ontario Long-term Energy Plan*, p. 9 and *Using Less Energy: Nova Scotia's Electricity Efficiency and Conservation Plan*, p. 2. The structures for achieving energy conservation in Ontario and Nova Scotia are fundamentally different than employed in Newfoundland and Labrador.

<sup>276</sup> Utilities 2012 Conservation Plan

large part by electric heating loads. With the interconnection of Muskrat Falls, avoided costs are likely to be driven more by the opportunity costs represented by export markets. Recognizing this change the Utilities have engaged a consultant to perform a Technical and Economic Potential Study for the IIS, the LIS and isolated systems to evaluate various energy efficiency and demand-side management measures. In addition, NLH has engaged a consultant to perform a marginal cost review. The Technical and Economic Potential Study is being finalized and the marginal cost review is expected to be finalized by the end of 2015. Such studies are timely.

The Utilities' focus on electric heating technologies is appropriate and likely to continue to be appropriate given the high penetration rate for electric heat and the major role that this has in driving peak electricity demand. NLH indicates that the penetration rate for electric heating is 85%. Not surprisingly, NLH indicates that NP's load (which is the primary driver of NLH's peak load) is highly influenced by the market share of electric heat within the residential customer class. NLH notes that its analysis indicates that "Except in extended periods of time with low fossil fuel prices, virtually all general service customer additions have electric heat based space heating systems installed as a primary heat source."<sup>277</sup> This suggests that conservation and demand management programs should focus on electric heating loads.

One technology that is receiving considerable attention and broader application on the Island is heat pumps. Given the high costs of electric heat and high fuel oil prices (at least until recently), mini split heat pumps are being installed in high numbers in Nova Scotia, New Brunswick and PEI. NP estimates that mini split heat pumps can provide savings of from 20 to 30% depending on the home and efficiency of the heat pump. However, the effectiveness of heat pumps declines as the ambient temperature declines so often they have an electric coil which switches on at low temperatures. Therefore, the increased penetration of heat pumps can exacerbate declines in system load factor as energy requirements decline more than system peaks. Consequently, it is important to ensure that the building envelope is highly efficient and that the heat pump itself is efficient (e.g., ultra-efficient cold climate heat pumps which are effective to -27 C). This can require changes to building codes and federal appliance efficiency standards. Power Advisory believes that Natural Resources Canada's (NRCan) appliance efficiency standards for heat pumps are relatively dated and that NL would benefit from a tightening of these standards. Government should consider working with NRCan to ensure that appliance efficiency standards for heat pumps are sufficiently stringent.

Mini split heat pumps can represent a cost-effective supplement to oil heat, with such systems not adding to peak load assuming that the oil heat system is maintained and operates when the heat pump is no longer effective given ambient temperatures. Where they are added with electric baseboard heating or if used in new construction with electric resistance backup, load control may be an important demand-side management program to manage peak loads.

As discussed, the Utilities pursuit of demand-side management programs is modest relative to that being pursued in many other provinces in Canada. The planning and analysis being currently performed by the Companies should provide a sound foundation for what are appropriately policy

---

<sup>277</sup> Progress Report on Load Forecasting Improvements, Newfoundland and Labrador Hydro , October 31, 2014.

decisions by government regarding what level of DSM investment it is appropriate for the NL's electricity customers to make. It is common practice for Governments to work with utilities to determine levels of savings and the associated rate impacts from such DSM portfolios and investment levels and based on this target funding levels.

## **8.2 Load Forecasting**

NLH has three durations of demand forecasts: (1) a short-term forecast, which looks out over the next seven days, is used for operational purposes; (2) a medium-term forecast, which has a five-year horizon and is used for budgeting and medium-term operational planning (e.g., outage scheduling and hydro-thermal optimization); and (3) a long-term forecast with a twenty-year horizon, which is used primarily for investment analysis and planning. Each is reviewed below.

### **8.2.1 Short-term Forecast**

The Ventyx Nostradamus model is used for short-term (one to seven days) hourly load forecasting. Nostradamus is a neural network algorithm which learns the pattern of load changes from weather and other time series variables including day of week, time of day, etc. This forecast is used by System Operations to assist in establishing generation reserves, unit commitment and scheduling, and equipment outage assessments. This forecast will have added importance when NL is interconnected with the North American grid given that it will help Nalcor assess the amount of surplus hydroelectric energy that can be made available to export markets.<sup>278</sup>

While NLH's short-term forecast was found to have not been a contributing factor to the 2014 outages,<sup>279</sup> the forecast was not reliably forecasting loads given that the weather conditions were outside the learning given colder temperatures and higher winds experienced for the model. Nonetheless, these forecasts adversely affected NLH's ability to respond to system conditions, delayed communications to customers and reduced its ability to plan for and mitigate such shortages.<sup>280</sup> NLH has devoted considerable resources to enhancing the performance of this forecast since the 2014 outages.<sup>281</sup> Furthermore, this forecasting tool was a major focus of Liberty's review of NLH's demand forecasting efforts.

While some of the recommendations and comments made by Ventyx appear contradictory, this is more a reflection of the challenges of such models and the need to balance different criteria. In particular, Ventyx recommended that NLH limit the training period to one to three years and noted that Nostradamus cannot reliably forecast load if meteorological conditions are different from those

---

<sup>278</sup> Under the terms of the Power Purchase Agreement between NLH and Muskrat Falls, a Nalcor affiliate will be responsible for marketing such surplus energy.

<sup>279</sup> Liberty Group, Review Supply Issues and Power Outages Newfoundland and Labrador Island Interconnected System (Liberty Report), p. 14.

<sup>280</sup> Liberty Report, p. 14.

<sup>281</sup> NLH indicates that it has had a training workshop with Ventyx, the supplier of Nostradamus, and updated the training parameters that the model considers. The model now considers cloud cover and degree of daylight, and equally as important there is a greater focus on meteorological data quality.

during the training period. This last point was a critical issue with respect to the model's performance during the January 2014 outage. With the model not able to capture load growth a shorter training period compensates for this limitation. However, a shorter training period limits the experience that the model has and its ability to forecast load during extreme weather conditions which are typical of system peaks. NLH indicates that it addresses these constraints by evaluating the weather data set reflected in the training period and contrasting it to historical extremes to assess the risk posed by more extreme weather and to assess under what weather conditions the model's performance might be adversely affected by limited experience.

The monthly reviews (including that for January 2015) of forecasting performance indicate that Nostradamus has performed well in the 2014-15 winter. Power Advisory has no further comments on NLH's application of Nostradamus or the forecasts that it is producing using this model.

### **8.2.2 Medium-Term Forecast**

The medium-term forecast relies in part on NP's forecast for the requirements of its customers. The medium-term forecast is used for budgeting and medium-term operational planning, such as equipment outage planning and hydro-thermal optimization.

In the small general service rate, customer and energy sales growth are forecast based on the growth in the service-producing sector of the GDP and changes in the price of electricity. In the large general service rate classes energy sales are also driven by changes in the service-producing sector of the GDP. However, in the largest general service category the forecast is based on information obtained from the specific customers.

Domestic customer growth is forecasted based on housing starts. Domestic electricity consumption is a function of the major end uses in the home, changes in energy prices and income.

NLH prepares the forecast of its rural customers and surveys industrial customers regarding their future requirements.

Power Advisory has no comments on NLH's medium-term demand forecast.

### **8.2.3 Long-Term Forecast**

NLH's long-term forecast has a time horizon of 20 years. NLH normally completes one long-term load forecast analysis annually beginning in the last quarter of each year. This forecast is used for assessing the long-term reliability of the IIS and for planning resource requirements to meet reliability criteria and is a key input into utility operating and investment plans for the IIS. For long-term requirements, both NP and NLH Rural and Island Systems are projected by NLH, while industrial requirements are guided by information directly from the individual industrial customers. The PUB typically doesn't review or approve NLH's long-term forecast. However, the forecast was assessed as part of the PUB's review of the Muskrat Falls project.

The long-term load forecasting model is an econometric based model that projects the island's energy and peak demand requirements 20 years into the future. The relationships between changes in electricity use and various economic measures are established using econometric techniques.

Separate forecasts are prepared for the domestic and general service retail rate classes for NP and NLH. NP's general service load is driven by provincial GDP, commercial business investment, efficiency adjusted oil prices, and technological change, which reflects increasing energy efficiency of building envelopes and end-uses. Domestic load for both NP and NLH is a product of average electricity consumption and customer numbers. NP's domestic customer forecast is driven by housing starts and completions, and personal income per customer. Average consumption per customer is forecast on the basis of personal disposable income, electric heat market share, heating degree days, the marginal electricity price in the previous year, and a variable which captures technological change or energy efficiency impacts.<sup>282</sup> Two separate equations forecast the penetration rate of electric space heat for new customers in NP's service territory and the conversion rate to electric space heat for existing NP customers and are used to predict the saturation rate for electric heating, which is used in the average use per customer model. NLH's domestic average use model is similar to that for NP, but also includes an electric hot water saturation rate.

Analysis of forecast performance conducted by MHI indicated that NLH's domestic forecast under-forecast domestic load consistently. At page 19 the report states: "The accuracy analysis compared 55 combinations of forecast value to actual year-end sales. The results showed that in 53 of the 55 cases, the domestic forecast was low. This bias would indicate that the load is growing for reasons not identified in the model (i.e. other end-uses, not just electric space heating) and/or that the assumptions driving the model are consistently conservative."<sup>283</sup> MHI noted that only electric space heat is explicitly captured in NLH's forecast specification. Increased consumption attributable to other end-uses would have to be captured by the personal income variable. However, this model specification is likely to have a hard time capturing fundamental changes in the penetration of end uses such as the penetration of mini split heat pumps, which is occurring on the Avalon Peninsula and more broadly across Atlantic Canada.

In its review, MHI recommended that NLH employ an end-use model where residential consumption is based on forecast average use per end-use and the forecast number of individual end-uses. Specifically, in an end-use model there is a separate forecast of changes in the average use per appliance to account for turnover of the appliance stock, efficiency improvements in the appliance stock and a forecast of the numbers of each individual appliance over the forecast horizon, with the product of these two matrices producing the residential forecast. Such models can more accurately represent changes in usage patterns, particularly when there are changing end uses,

---

<sup>282</sup> With the forecast based on electricity prices, NLH iterates on prices and investment plans until the updated load forecast does not substantially change the generation expansion sequence and future capital requirements.

<sup>283</sup> Manitoba Hydro International Report on Two Generation Expansion Alternatives for the Island Interconnected Electrical System, 2012 p. 19.

e.g., the potential for increased penetration of ground-source heat pumps. Given the significant portion of total system electricity requirements represented by this class and its critical role in setting the system peak, such forecast enhancements are likely to be valuable.

NLH's acknowledged the importance of electric heating in its response to a data request by the PUB, but did not acknowledge the limitations of an econometric model in capturing the effects of new technology which isn't reflected in the period that was used to establish the model specification.

“In its current econometric approach to its energy and peak demand forecasting, NLH accounts for the most significant end-use on the Island Interconnected System which is electric heating. Both the energy and peaks loads experienced on the Island system have been dominated by this single end-use for the past two decades or longer and with the continued preference for electric heat by domestic customers it is not expected to change in the longer term.”<sup>284</sup>

NLH estimates that employing an end-use model for the residential sector would require at least an additional staff person to support and that there would be additional expense for appliance saturation and penetration surveys. NLH notes that it employed an end-use model in the 1990s for several years, but discontinued using it given budget pressures. Similarly, NP developed and employed an end-use model, but also has discontinued its use. In a response to a PUB data request on end-use modeling, NLH indicated that

“Over the time frame in which NLH used this end-use model it became evident that a much greater level of analytical effort was required to maintain this modeling approach compared to the traditional econometric approach being used. This was due to the additional customer end-use data detail required for forecasting end-use loads. In addition, it was perceived by NLH at that time that end-use forecasting required a significant level of judgment with respect to future efficiency levels of end-use equipment that was not required with an econometric approach as the econometric forecasting approach could estimate overall efficiency changes from the historical data it relies on.”<sup>285</sup>

While an end-use model isn't essential to developing a reliable forecast for the residential sector, Power Advisory believes that NLH and NP will want to closely monitor the penetration of mini split heat pumps, develop analytical methods to properly assess the implications for changes to domestic energy requirements and overall system load shapes. Major utilities commonly employed end-use models when they were responsible for planning for customers' future requirements. However, with the restructuring of many power markets where customer requirements can change dramatically as customers elect to be served by competitive suppliers, end-use models are less common than they once were. Nonetheless, end-use models do represent best practice. However, such models are likely not justified for the NL system given the incremental cost.

---

<sup>284</sup> Outage Inquiry, PUB-NLH-058.

<sup>285</sup> Outage Inquiry Data Request Response, PUB-NLH-058



The industrial sector consists of only four large industrial customers: the pulp and paper mill in Corner Brook operated by Kruger; an oil refinery at Come-by-Chance; a copper/zinc mine at Duck Pond, which closed in mid-2015; and a hydrometallurgical processing plant being commissioned by Vale at Long Harbour. The industrial forecast is prepared on an individual, case-by-case basis, with direct customer contact concerning future operational plans.

In its Interim Report, the PUB recommended that NLH “incorporate sensitivity analyses to weather extremes in all forecasting and supply and planning decision evaluations.”<sup>286</sup> NLH notes that “this practice would allow NLH to better understand the generation and supply impacts associated with uncertain and differing load futures...while the primary focus of the current review was with respect to winter peak demand forecasts, the recommendation to complete sensitivity analysis applies to both demand and energy forecasts.”<sup>287</sup> Power Advisory notes that while sensitivity analysis can be performed for peak load forecasts, the critical issue is to recognize the uncertainty inherent in the forecast whether it is in the underlying weather conditions or customer’s response to these weather conditions and to ensure that this uncertainty is captured in the peak load forecast or recognized as an element of uncertainty that needs to be reflected in the reserve requirement. In fact, in many jurisdictions peak loads are forecast at P50 condition, but to ensure system reliability the uncertainty regarding these peak load values is reflected in a higher system reserve requirement.

#### **8.2.4 Peak Load Forecast**

NLH employs a separate forecasting methodology to forecast the system peak. The IIS system peak demand forecast is prepared by estimating four peak demand forecast sub-groups: NP peak demand, NLH rural peak demand, industrial demand and NLH transmission peak demand. Not surprisingly, the NP peak demand is the most significant contributor to the peak forecast and is estimated using a regression equation. This equation considers the number of electric and non-electric heating residential customers, the general service energy requirements, wind-chill, electricity prices in the previous year, technical change/conservation, and various time and monthly variables. NLH often judgmentally adjusts this forecast to account for anticipated changes that are not reflected in the model variables.<sup>288</sup>

---

<sup>286</sup> p. iii

<sup>287</sup> Progress Report on Load Forecasting Improvements, p. 23.

<sup>288</sup> For example, NLH has recently increased the peak load forecast by 2.5 MW per year to account for anticipated declining efficiency gains

## 9. Investment Planning

This section covers both short-term investment planning and long-term investment planning. The short-term planning relates to the annual capital budgeting process and the long-term planning can be generation planning, transmission planning or integrated resource planning (IRP) in which the preferred overall plan is prepared taking into account generation, transmission and in some cases distribution factors and the interrelationships amongst these three aspects of the utility's business.

### 9.1 Regulatory Requirements

The type of economic regulation used in Newfoundland and Labrador is commonly referred to as cost of service regulation. This is the most common form of economic regulation applied to electricity utilities operating within Canada. Four fundamental aspects of utility businesses are typically governed under cost of service regulation: (i) the level of investment in the electricity system to provide service, (ii) the costs to operate the electricity system to provide service, (iii) the level of return on that investment, and (iv) customer rates. Other forms of economic regulation, including performance-based regulation and price caps, have also been applied to Canadian utilities.

The legislation in Newfoundland and Labrador governing the electricity sector is described in detail in Section 3.1. With respect to investment planning there are two key requirements of the legislation as follows:

Section 41 of the *Public Utilities Act* (PUA) requires utilities to submit an annual capital budget application for the next calendar year for approval by the PUB no later than December 15<sup>th</sup> each year.

Section 6 of the *Electrical Power Control Act* (EPCA) includes the following requirements:

#### Planning of future power supply

- (1) The public utilities board has the authority and the responsibility to ensure that adequate planning occurs for the future production, transmission and distribution of power in the province.
- (2) The public utilities board may direct a producer or retailer to perform such activities and provide such information as it considers necessary for such planning to the public utilities board or to any other producer or retailer on such terms and conditions as it may prescribe.
- (3) For the purpose of this section, the public utilities board may adopt those rules and procedures that it considers necessary or advisable to give effect to the subsection.

With these legislative requirements and underpinnings, the PUB has broad authority and responsibility with regard to the investment planning activities of the utilities that it regulates.

## 9.2 Capital Budgeting Process

In order to facilitate the annual capital budget application and approval process, the PUB issued provisional Capital Budget Application Guidelines on June 2, 2005. A revision to these provisional guidelines was issued in October 2007. No revisions have been issued since, but the PUB has worked on such revisions. The revision of October 2007 also indicates comments by NLH, NP and the PUB itself on the provisional guidelines. In its order P.U. 30(2007) dated November 22, 2007 on NLH's capital budget request for 2008 that the PUB required NLH to include a five year capital expenditure plan as part of its capital budget request for 2009 and subsequent years.

The guidelines establish the schedule to be followed with respect to the annual capital budget requests by NLH and NP. This schedule is shown in Table 19.

**Table 19: Capital Budget Application Schedule**

Action	Utility	
	NP	NLH
Application filed with supporting evidence and copied to interested persons	July 15	August 1
Notice Published	July 22	August 8
Intervenor submissions filed	August 2	August 19
i) RFIs files and ii) Requests for technical conference made	August 5	August 22
Replies for RFIs	August 19	September 6
Target date for technical conference to be held	August 26	September 13
i) Intervenor evidence filed, ii) RFIs arising from technical conference filed and iii) Request for a hearing held	August 30	September 17
i) RFIs on intervenor evidence and ii) Notice if hearing will be held	September 4	September 21
i) Replies to RFIs on intervenor evidence and ii) Replies to RFIs arising from the technical conference	September 11	September 28
Hearing, or if no hearing written submissions must be filed	September 30	October 15
Decision	November 15	December 1

Source: PUB

Subsection 41(3) of the Act prohibits a utility proceeding with purchases that exceed \$50,000 and leases with annual payments in excess of \$5,000 without the prior approval of the PUB. These threshold amounts are very low relative to the magnitude of annual expenses faced by utilities like NLH and NP and it is considered by Power Advisory, taking into account best practices in other jurisdictions, that these values should be increased to improve the overall efficiency of the regulatory process. See discussion in Section 6.2.5.

In the guidelines the PUB specifies that the capital budget requests should be categorized into one of three expenditure levels and outlines the supporting information to be provided for projects in each size category. These requirements are outlined as follows:

Projects with expenditures under \$200,000 are to be supported with evidence showing that the expenditure is prudent and necessary to provide reasonably safe, adequate, just and reasonable service. These expenditures are to be considered based on the written record filed, including the utility's application, any relevant RFIs and replies, other evidence and written submissions.

Projects with expenditures between \$200,000 and \$500,000 are to be supported with evidence showing that the expenditure is prudent, or necessary to provide reasonably safe, adequate, just and reasonable service. The utility is expected to provide the following information where appropriate and available:

- 1) Age of equipment or system
- 2) Major work/upgrades completed since installation/implementation
- 3) Anticipated useful life
- 4) Summary of maintenance records
- 5) Summary of outage statistics
- 6) Relevant industry experience
- 7) What maintenance/support arrangements available (internal and external)
- 8) Vendor recommendations
- 9) Availability of replacement parts
- 10) Safety performance (if relevant)
- 11) Environmental performance (if relevant)
- 12) Operating regime (continuous, cyclic, standby, etc.)
- 13) Net Present Value NPV calculation
- 14) Levelized cost of energy
- 15) Cost benefit analysis
- 16) Other legislative or regulatory compliance requirements
- 17) Historical average and/or unit cost information
- 18) Forecast customer growth estimate

- 19) Energy efficiency benefits
- 20) Losses incurred during construction
- 21) Anticipated sequences of maintaining the status quo
- 22) Any other alternatives considered
- 23) Description of proposed solution
- 24) Budget estimate
- 25) Project schedule
- 26) Detailed report/analysis of condition (if available)

These expenditures are normally to be considered based on the written record filed, including the application, any relevant RFIs and replies, other evidence and written submissions. These expenditures may be challenged during a hearing if the PUB, on its own motion or upon receiving a request from an intervener, determines that an oral hearing is necessary to properly assess whether the expenditure should be approved.

Projects with expenditures over \$500,000 are considered significant projects which must be supported with more comprehensive and detailed documentation than other expenditures. It is expected that all the items in the check list will be addressed with either the information provided or an explanation of why it is not appropriate in the circumstances. Where appropriate, a utility is expected to provide a report/analysis by a qualified engineer or other appropriate expert in support of the expenditure.

Expenditures in excess of \$500,000 are open to review at a hearing if it is determined by the PUB, upon request or on its own motion, that the expenditure should be reviewed in an oral hearing. The guidelines also require that each expenditure be categorized as either mandatory, normal capital or justifiable. The guidelines provide definitions for each and outline the supporting information that is required for each category.

The guidelines also provide for Supplemental Capital Expenditures. These are expenditures that were not anticipated and included in the capital budget for the year and should not wait until the following year.

Under Section 41 of the *PUA* a utility is also required to file a Capital Expenditure Report by March 1 of each year on the annual capital expenditures to December 31 of the previous year. This report will include a detailed explanation of each actual expenditure variance from the approved expenditures where the variance is more than \$100,000 and 10%.

## 9.3 Recent Capital Budget Applications

### 9.3.1 NLH

NLH filed its capital budget application for the year 2015 with the PUB on August 1, 2014. This application was for a capital budget of \$79.9 million. In its Order P.U. 50(2014) dated December 2, 2014 the PUB approved a capital budget for NLH for the year 2015 of \$76.8 million. NLH filed its \$183.7 million 2016 capital budget with the PUB on August 3, 2015.

During 2014, NLH applied for several projects under the Supplemental Capital Expenditures provision. The application for approval of expenditures for a combustion turbine generator to be installed at the Holyrood Thermal Generating Station was the largest such application. In its application dated April 10, 2014, NLH requested approval for expenditure of \$119 million for this unit. The following is a summary of the evidence for this application:

- 1) NLH owns and operates 1,692.6 MW of generating capacity (based on gross continuous rating) on the IIS. In deciding when to add a generation source, NLH uses a LOLH criterion which is a means of assessing the likelihood that NLH will be unable to meet its customer load due to a generation capacity shortfall. NLH has been using a LOLH standard of 2.8 hours/year in its generation capacity analysis whereby if in the analysis the 2.8 hours is exceeded, it would identify a requirement for additional capacity
- 2) The LOLH criterion NLH uses is based upon expert advice it has received supplemented by its experience. Adding generation sources in advance of their demonstrated need is costly for the ratepayer; adding generation sources later than their demonstrated need can cause an inability to meet customer loads to a greater extent than is considered reasonable and adequate
- 3) The LOLH for NLH's IIS generation capacity reliability is forecast to exceed 2.8 hours in 2015. For that reason, NLH has been planning to install 60 MW of additional generation on its system in late 2015 in the form of a combustion turbine
- 4) NLH has completed an assessment for the location of the combustion turbine and has determined that the Holyrood Generating Station site is the most appropriate
- 5) Due to its experiences in January 2014, NLH has revisited its LOLH guideline and has run sensitivity analyses with additional customer electrical loads and higher than expected forced outage rates at its generating stations. Those analyses indicate that it would be prudent, if practicable, to advance the installation of the combustion turbine and to increase the generating capacity of the combustion turbine it installs

- 6) In investigating the available combustion turbine opportunities, NLH has learned that there are options available to procure and install existing combustion turbines of a larger capacity, at an earlier timeframe than originally planned, and at approximately the same cost that was earlier estimated for a 60 MW turbine. That is, NLH has learned that suppliers can provide combustion turbines in the 100 MW range and have them installed and commissioned at the Holyrood site within eight months of making the commitment
- 7) Given the reliability benefits that would be achievable by having a combustion turbine of approximately 100 MW installed at Holyrood to be in-service for the 2014-2015 winter, NLH is applying for approval for a capital project for this generation addition
- 8) Therefore, NLH makes Application that the Board make an Order approving, the capital expenditure of \$119,000,000 for the purchase and installation of a 100 MW (nominal) combustion turbine to be installed at Holyrood
- 9) The Applicant submits that the proposed capital works and expenditures are necessary to ensure that its generation system can continue to provide service which is reasonable safe and adequate and just and reasonable

In its Order P.U. 16(2014) the PUB approved the application but specified “with the issues of costs and cost recovery to be determined by the Board in a future Order”. The Order also summarizes the input the PUB received from various interveners to the very brief proceeding. In most cases the interveners agreed that NLH should proceed with this project in the interests of system reliability during the winter of 2014/2015 but noted that the requirement for such a quick decision on an expenditure of this size indicates shortcomings in the processes followed. For instance, on page 2 of the Order:

“Newfoundland Power also submits that the Liberty report suggests that the high risk of supply-related emergencies is attributable to acts or omissions of Hydro related to planning, maintenance and operation of its generation and transmission assets.”

### **9.3.2 NP**

NP filed its capital budget application for the year 2015 with the PUB on June 26, 2014. This application was for a capital budget of \$94.2 million. In its Order P.U. 40(2014) dated October 9, 2014 the PUB approved a capital budget for NP for the year 2015 of \$94.2 million.

## **9.4 Capital Budget Preparation**

#### 9.4.1 NLH

A review of NLH's process for the development of its capital budget program indicates that it is comprehensive, thorough and quite detailed with sufficient reviews. It is considered that NLH's capital budget planning process is adequate for the size of NLH's system.<sup>289</sup> The timelines followed are shown in

---

<sup>289</sup> NLH's "Capital Budget Process Flow" document dated March 2014.



Table 20 which also shows the main steps in preparation of an annual capital budget.<sup>290</sup>

Although the capital budget application has 24 main steps, it is worth noting the first step – Identify the Need. Any NLH personnel may recognize the need for a capital project and discuss it with the appropriate supervisor/manager and asset planners to initiate a proposal for inclusion in NLH’s twenty-year capital plan. The need can be identified at any time throughout the year but to accommodate process flow and meet deadline dates, time limitations have to be set regarding getting a proposal onto the Master List of Capital proposals.

- a) Operations personnel discuss with the asset/regional/plant manager the need for a capital project. The Long Term Asset Planner (LTAP) ensures that the regional/plant manager is aware of the capital project being proposed. The Asset Manager develops initial scope definition, contacts the appropriate discipline in Project Execution and Technical Services (PETS) for further scope development, (if necessary) and project costing

---

<sup>290</sup> Capital Budget Process Flow – Description of Activities and Time Line, Newfoundland and Labrador Hydro, March 2014.

**Table 20: NLH Capital Budget Preparation Time Line**

<b>No.</b>	<b>Description</b>	<b>Deadline</b>	<b>Department</b>
1	Identify the Need	October 31	Operations
			Long Term Asset Planning
			Asset Management
			System Planning
			Project Execution and Technical Services
	Information Services, General Services and Environmental services		
2	Review Master List of Proposals	November 30	Capital Budget Coordinator, Managers and Vice Presidents
3	Update Inputs in the Project Estimating Template	November 30	System Planning
4	Prioritization of Capital Proposals in Year One of the Capital Plan	December 31	Capital Budget Coordinator, Managers and Vice Presidents
5	Examine Proposals to Confirm Whether capital or Operating	January 15	Capital Budget Coordinator and Managers
6	Determine Proposals Requiring Outages	January 31	Capital Budget Coordinator and Managers
7	Finalize the Master List of Proposals	January 31 and May 31	Managers
8	Determine Proposals that Require a Cost Benefit Analysis	January 31	Capital Budget Coordinator, Managers and Investment Evaluation
9	Determine Proposals that Require Environmental Approval	January 31	Capital Budget Coordinator, Managers and Environmental Services
10	Determine Completion Dates for Proposals in the First Year of the Five-Year Plan	January 31	Capital Budget Coordinator and Managers
11	Update Escalation rates in the Project Proposal Summary Template	January 31	System Planning and Information Services

12	Update Cost Benefit Analysis template	January 31	Investment Evaluation
13	Prepare the proposal	Deadline	Project Execution and Technical Services and Capital Budget Coordinator
14	Prepare for Review	Deadline	Capital Budget Coordinator and Project Execution and Technical Services
15	Review Proposals	Deadline	Capital Budget Coordinator, Managers and Vice Presidents
16	Review Proposals Process Table	Dates for Milestones	Capital Budget Coordinator, Managers and Vice Presidents
17	Ensure Proposals are Suitable for Submission to the PUB	Deadline	Managers, Vice Presidents and Rates and Regulatory
18	Complete Proposals for Other Four Years	May 31	Capital Budget Coordinator
19	Review Proposals - Leadership Team Review	June 8	Leadership Team and Asset Accounting
20	Respond to Leadership Team review	Deadline	Capital Budget Coordinator and Managers
21	Review proposals -- Board of Directors Review	June 28	Board of Directors and Asset Accounting
22	Submit Capital Budget and Five-Year Plan to the PUB	July 22	Asset Accounting
23	Review of Capital Budget Application by the PUB	September	Capital Budget Coordinator, Managers and Vice Presidents
24	Approval of Capital Budget Application by the PUB	December	

- b) Long-term asset planners identify capital projects related to load growth and advise other appropriate departments in PETS of the need for a capital proposal. System Planning develops initial scope definition, project description and justification and contacts the appropriate discipline in PETS for project costing
- c) PETS disciplines identify capital projects related to system enhancements, cost savings, energy efficiency, and/or operational productivity improvements. In conjunction with Operations personnel, capital proposals are developed to address the need
- d) Information Services and General Services personnel identify capital projects in their areas. They define the scope of work and prepare a cost estimate for the capital proposal

In the preparation of the capital budget request a prioritization scheme is used to rank projects. In doing the prioritization, each project is evaluated based on 12 criteria with each criterion having a number of factors, each of which has a factor weight. The scores for each project are totaled and the projects are ranked based on each project's evaluated score.

The Vice President, Chief Financial Officer and President and Chief Executive Officer of NLH and Nalcor's Vice President of Project Execution, Technical Services and Asset Management review and approve the completed capital budget prior to it being submitted to NLH's Board of Directors for approval. Once it is approved by NLH's Board of Directors, the submission is made to the PUB.

#### **9.4.2 NP**

NP's planning process is like that used by many distribution utilities. It involves load forecasting, modeling system components and system studies to identify deficiencies in the power delivery system. It also involves engineering analysis of different system configurations, economic analysis, application of engineering standards, judgment and experience. NP on a regular basis performs studies such as power flow, short circuit and voltage regulation etc.

The objectives of the planning studies are to assess the impact of load growth, aging infrastructure and the addition of new generation sources to the existing electricity system. When deficiencies are identified engineering studies are carried out to develop appropriate solutions.

NP maintains models of the electricity system that enable it to analyze and evaluate its system. These models are used in forward-looking planning studies and also for operational planning.

In planning and monitoring the capability of its system, NP applies criteria for both voltage and current (or capacity). The various components of the power delivery system are monitored on an ongoing basis with reference to these criteria, and any issues identified are addressed as appropriate.

In addition to considering the capability of its system relative to the applicable voltage and capacity criteria, NP also considers the extent to which service reliability concerns may require that redundant capacity be incorporated into its system.

During the past 10 years, load growth has not resulted in a requirement for any new transmission lines during that period. However, it has resulted in several capacity additions to the Company's substations.

NP completes an annual review of its power delivery lines. The results of this review are considered as part of the Company's capital budget process, and regularly documented in capital budget filings. When necessary, a more detailed study is carried out to determine the best approach to rebuilding a line.

### **9.5 Long-term Planning**

Both NLH and NP carry out long-term planning studies and these provide input to the capital budgeting process as well as supporting other utility processes. The planning parameters and reliability targets used for these plans are discussed in Section 7.2

In NLH, both generation and transmission planning are carried out under the responsibility of the Vice President, System Operations & Planning.

NLH's generation planning group is responsible for development of the long-term least cost generation expansion plan over a planning horizon of 20 years based on the forecasted load demand, existing generation fleet, committed new generation additions, life extensions and upgrades, available generation resources and technologies and reliability planning criteria. The least cost plan is the one with the lowest cumulative present worth (CPW) among the expansion plans analyzed, taking into account all costs including capital investment, fuel cost, O&M cost and other costs when applicable. Sensitivity analysis is carried out to assess the robustness of alternative scenarios to possible change in costs, load growth and other factors.

NLH's transmission system planning group is responsible for monitoring the transmission systems to determine when a component's capacity fails to meet the established planning criteria using load flow, short circuit and stability analyses. When deficiencies are found, the group prepares and tests alternative solutions to ensure the transmission system meets the planning criteria into the future. Where appropriate, a life cycle least cost analysis of technically viable alternatives is completed and detailed reports prepared with recommendations on preferred solutions.

Once technically viable solutions are defined through the load flow and dynamic simulations, short circuit studies are repeated to assess impact on interrupting ratings of existing circuit breakers. Cost estimates for technically viable solutions are requested from Project Execution and Technical Services and the least cost alternative over the appropriate life cycle selected. A detailed report is completed including a preliminary single line diagram.

NLH's distribution system planning group is responsible for monitoring the distribution systems (both interconnected and isolated) to determine when components fail to meet the established planning criteria using load flow and short circuit analyses. When deficiencies are found, the group prepares and tests alternative solutions to ensure the distribution systems meet the planning criteria into the future. Where appropriate, a least cost analysis of technically viable alternatives is completed and detailed reports prepared with recommendations on preferred solutions.

NP follows similar procedures in long-term planning for its distribution system.

As noted in Section 3.1.1, the *EPCA* gives the PUB the authority and responsibility to ensure that adequate planning for the future generation, transmission and distribution of power is done and that the information resulting from such planning is provided to the PUB and other interested parties. Despite this legislative requirement, the PUB has not convened a hearing in which detailed long term plans for the province's electric power systems, often referred to as Resource Plans or Integrated Resource Plans (IRP), in which demand and supply-side resources are evaluated on an integrated basis, are presented and subject to review by the PUB, the Consumer Advocate and other interested parties.

An IRP addresses and seeks to balance a number of important factors to a power system such as reliability, environmental stewardship, cost effectiveness, social and demographic factors and energy conservation. Such plans provide all stakeholders with information on strategic direction for the province's electricity sector and provide the opportunity, through the review process, to test the

load forecast, planning parameters, assumptions, procedures and conclusions thus allowing any desirable modifications to be made to the plan while necessary investments can still be implemented cost effectively.

With the completion of the Muskrat Falls project and the Labrador-Island Link and Maritime Link HVdc lines, NL will have sufficient power supply to meet projected customer needs for a number of years. Nevertheless, there remain many factors that will require decisions in the upcoming years and a public IRP process would provide a transparent framework for the evaluation of these. Some of these might include:

- Replacement of aging assets taking into account a system-wide view
- Full retirement of Holyrood Generating Station
- Integration of significant amounts of wind generation
- Ability to enter into firm export contracts

A number of jurisdictions require the power utilities to prepare an IRP and make this available to stakeholders. In some cases there is extensive stakeholder consultation in the preparation of the IRP and in this case there may not be a formal public utilities board hearing to review the completed plan. In other cases, the IRP is filed with the public utilities board and is subject to detailed scrutiny as part of either a rate hearing or a hearing focused on the IRP itself. Nova Scotia, New Brunswick, Ontario and British Columbia are some of the Canadian jurisdictions where detailed IRPs have been prepared and customers and stakeholders have been involved in their preparation or review. For instance, NB Power filed its Integrated Resource Plan 2014 as evidence for its general rate application filed in late 2014.

Where future generation investment is to be performed on a market-basis there is less of a need for IRP processes. However, in cases where the market is not large enough to be truly competitive or where government policy shapes the electricity sector, it can still be useful for a utility to prepare a resource plan that assesses future electricity requirements. In Québec where Hydro-Québec Distribution issues RFPs to satisfy increases in its customers' requirements, Hydro-Québec Distribution is responsible for preparing a resource plan that identifies future customer requirements.

## **10. Asset Management**

Broadly speaking, asset management encompasses the procedures, programs and processes used to care for each utility asset over its lifecycle. This includes the design, implementation and commissioning activities to bring the asset into service, the routine operation and maintenance of the asset during its operating life, sustaining capital investments and ultimately the de-commissioning and removal of the asset. The period of years during which an asset can operate cost effectively and reliably is directly related to the effectiveness of the asset management program during each stage of its life. As assets age, the cost of keeping them operating efficiently typically increases as does the likelihood of operating problems that reduce reliability. Tradeoffs need to be made between the cost of maintaining an asset and the cost of replacing it with a new asset. This section provides an overview of the current asset management programs used by NLH and NP and assesses the impacts on reliability and cost.

### **10.1 Summary of Existing Assets**

#### **10.1.1 NLH**

The age of NLH's generating assets was reviewed in Section 2.3.2. As is evident from this discussion almost 50% of these are over 40 years old.

Table 21 shows the age ranges for NLH's transmission system poles and lines. For steel/aluminum lines, over 65% of the components are over 40 years old while for the wooden lines, 30-45% of the components shown in the table have been in service for over 40 years. Similar information is provided in Table 22 for NLH's distribution assets. Close to 50% of distribution substation transformers are in excess of 40 years old. In the case of wood poles in the distribution system, some 28% are over 40 years old but over 80% of the wood pole lines exceed 40 years of age.

#### **10.1.2 NP**

NP does not use the terms "transmission" and "sub-transmission" to differentiate portions of its transmission system. Instead, NP uses the terms "transmission system" or "transmission" line to refer to the parts of its electrical system that transmit electricity from the in-feed points of the NLH bulk electricity grid, or from its own generation sources, to NP's distribution stations.

NP operates a transmission system that comprises 104 transmission lines with a combined total length of 2,062 kilometres, together with the associated line terminations and substation transformers. NP's transmission system operates primarily at voltages of 66 kV and 138 kV, with a very limited portion operating at 33 kV. The distribution of NP's transmission and distribution poles and transmission line assets by age range is shown in Table 23.

**Table 21: NLH Transmission Facilities by Age**

Age	No. of Wooden Poles	No. of Steel / Aluminum Structures	No. of Wooden Structure Lines	No. of Steel /Aluminum Structure Lines
0 - 10	1,334	0	1	0
11 - 20	2,561	266	3	3
21 - 30	5,216	445	6	1
31 - 40	8,245	463	12	2
>40	8,312	2,455	18*	11
<b>Total</b>	<b>25,668</b>	<b>3,629</b>	<b>40</b>	<b>17</b>

\* Includes section of TL-212 that was built with wooden structures

Source: NLH

**Table 22: NLH Distribution Facilities by Age**

Age	No. of Wooden Poles	No. of Wooden Structure Lines	No. of Transformers
0 - 10	7,450	0	4
11 - 20	6,983	1	3
21 - 30	11,112	8	7
31 - 40	9,487	4	11
>40	13,542	65	22
<b>Total</b>	<b>48,574</b>	<b>78</b>	<b>47</b>

\* Includes section of TL-212 that was built with wooden structures

Source: NLH

NP has 306 distribution feeders, the majority of which have been in service for many years. New feeders are added from time to time to serve new loads but for the most part new feeders are introduced as a result of configuration changes to address load growth.

NP has 130 substations located throughout its operating territory. Once a substation has been constructed, it typically remains in service indefinitely. Substations are routinely upgraded or refurbished as (i) equipment becomes obsolete; (ii) infrastructure deteriorates; or, (iii) electrical load is forecast to grow beyond existing substation capacity. The age ranges of NP transformers are shown in Table 24.



**Table 23: Distribution of NP Transmission and Distribution Facilities by Age**

Age	Poles by Age Group		Transmission Lines (km)
	Transmission	Distribution	
0 - 10	4,237	34,138	253
11 - 20	3,402	31,203	167
21 - 30	2,290	43,886	117
31 - 40	7,937	43,051	724
41 - 50	4,768	36,890	558
51 - 60	2,121	11,752	233
60+	77	9,100	3
Total	24,832	210,020	2,045

**Table 24: Distribution of NP Transformers by Age**

Age	Power Transformers
0 – 10	9
11 – 20	7
21 – 30	18
31 – 40	66
41 – 50	50
51 – 60	21
60+	5
Total	176

Source: NP

Approximately 28% of the transmission poles, 27% of the distribution poles and 39% of the transmission lines (by length) are more than 40 years old. The age of approximately 41% of the transmission and distribution poles and the transmission lines (by length) are between 20 to 40 years, which is an indication of rapid growth of NP's assets during this period.

Considering the age of a transformer as an indication of the age of the respective substation, it is noted that approximately 43 % of the substations are more than 40 years old and 81% of the substations are more than 30 years old.

## 10.2 Asset Management Strategy

### 10.2.1 NLH

In accordance with utility best practice, NLH operates using an asset management program. Liberty noted that in some areas NLH's asset management practices are consistent with best practices. In particular, Liberty noted that "Hydro justifies transmission system and wood pole line preventive maintenance activities using Value Based RCM ("Reliability Centered Maintenance")... The value based approach comprises a systematic, objective, well documented approach to maintenance optimization. The approach employs accepted risk assessment concepts."<sup>291</sup> Liberty also noted that "Hydro conducts vegetation management consistent with good utility practice and the needs of the system...Recent improvement in air blast circuit breaker maintenance has produced conformity with good utility practices."<sup>292</sup>

The PUB's May, 2014 interim report on the January, 2014 system outages listed five asset management issues the PUB asserted had caused or contributed to these outages.<sup>293</sup> Liberty did not establish a causal relationship between these factors and the 2014 outages, but noted that the number and nature of the failures that occurred in a compressed timeframe raised questions about NLH's operation and maintenance of equipment. In Liberty's subsequent December 17, 2014 "Report on Island Integrated System to Interconnection with Muskrat Falls addressing Newfoundland and Labrador Hydro", Liberty noted that NLH "has made significant progress in addressing" issues identified in its Interim Report. The PUB later initiated a prudence review of various NHL decisions having a bearing on system reliability and the 2014 system outages that is expected to conclude in late 2015 or early 2016.

As a key part of its asset management strategy, NLH has established staff positions which are responsible for the identification, planning and successful execution of required work. They collectively work together to ensure the development of Annual Work Plans (AWPs) and manage the execution of those plans across months, weeks, and individual activities. The AWP contains the scope of essential work for safe, reliable and sustainable production and delivery of electricity to customers, execution and outage schedules and supporting resource plans. These plans are initiated based upon known work, prioritized and loaded into the plan through team-based evaluation. The plan is holistic and includes preventive and corrective maintenance, training, as well as project work. The AWP flows into monthly and weekly schedules and is the baseline for control and management of change.

Specific points of control are established to monitor the execution of work at the activity level, the monthly level and the annual level. This program is considered to be in accordance with best practices followed by electric utilities.

NLH's key functions in its asset management are as follows:

---

<sup>291</sup> Liberty December 17, 2014 Report, p. 83.

<sup>292</sup> Liberty December 17, 2014 Report, p. 97.

<sup>293</sup> PUB-Report-May15-2014.pdf

- Long term asset planning
- Short-term work planning and scheduling
- Critical spares management
- Work execution
- Operations

NLH reorganized extensively to bring more accountability and consistency to asset management at all levels of the organization, notable changes include positions supporting the following:

- Office of Asset Management
- Asset Owners
- Long Term Asset Planning
- Work Execution
- Short Term Work Planning and Scheduling
- Project Execution
- Operations
- Support Services

### **10.2.2 NP**

In its report dated December 17, 2014 “Report on Island Integrated System to Interconnection with Muskrat Falls addressing Newfoundland Power Inc.”, Liberty Consulting Group notes that “The program, organization and staffing of Newfoundland Power’s asset management functions are sound,” and that its “transmission line and pole inspection and corrective maintenance practices conform to good utility practice”.

NP recognizes that stability and predictability of its capital program is important to maintaining stable customer rates. The Company’s asset management philosophy is to balance the maximization of asset life with proactive asset replacement. The benefit of maximizing asset life is lower overall capital costs. However, aged assets pose an increased risk of in-service failure which results in potential safety risks, increased operating costs and reduced reliability.

On an annual basis, NP submits its Substation Refurbishment and Modernization project to the PUB. The Substation Refurbishment and Modernization project provides a structured approach for the overall refurbishment and modernization of substations and coordinates major equipment maintenance and replacement activities. The project is based on an annual assessment of (i) the condition of the infrastructure and equipment, (ii) the need to upgrade and modernize protection and control systems, and (iii) other relevant work.

Refurbishing or replacing aging assets is a continuous process in a utility. It is not unusual that a utility has a wide spectrum of age in its assets. What makes NP’s transmission system unique is its

location, weather and the experience it has gained with regards to utilization of assets over operating lives. Nevertheless, it is expected that NP will continue refurbishing/replacing its assets at rather a high pace.

### 10.3 Asset Management Process

#### 10.3.1 NLH

NLH’s asset management process involves several different aspects, including:

- a) An Asset Management Framework
- b) A Staged-Gate Process for Planning and Executing Individual Projects within the Long Term Asset Management Plan
- c) A Process for Annual Project Plan Development
- d) Condition Assessment and Monitoring
- e) Benchmarking/Expert Reviews, including Project Execution/Management

NLH’s Asset Management Framework is illustrated in Figure 55.<sup>294</sup>

**Figure 55: Nalcor Asset Management Framework**

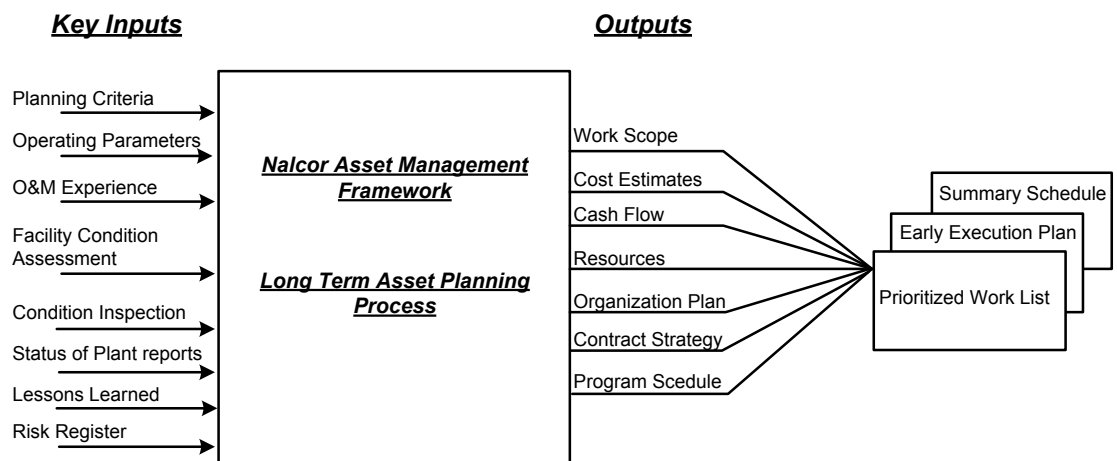

The Asset Management Framework used by NLH identifies the steps/stages that NLH's projects go through in order to become part of the overall Asset Management plan through to execution of both projects and maintenance programs. The following processes, procedures, methods and practices are utilized to ensure the power system is maintained to supply safe and reliable electricity:

- Identification of the key asset management accountabilities and processes of Asset Owner; Long Term Asset Planning; Work Execution; Operations; and Short Work Term Planning and Scheduling;
- Project management manual;
- Capital and operating budget process;
- Work methods;

<sup>294</sup> The asset management framework is formerly identified as Nalcor’s, but it is also employed by NLH.

- Work protection code;
- Preventive maintenance (PM) program within the Computerized Maintenance Management System (CMMS);
- Condition assessments and inspections;
- Standard maintenance check sheets for critical assets;
- Wood pole line management program;
- Power transformer dissolved gas analysis program;
- Engineering standards;
- System planning criteria;
- Planned outage database;
- Work orders;
- Integrated resource planning;
- Vibration and oil analysis;
- Thermography;
- Standard Operating Procedures;
- Engineering Directives; and
- Maintenance Standards.

The staged gate process involves 5 phases as follows:

- Phase 1 – Need Identification
- Phase 2 – Apply Plan
- Phase 3 – Apply Detailed Plan
- Phase 4 – Execute
- Phase 5 – Operate and Close-Out

The key actions associated with each phase are identified and in order to pass through the “gate” to the next phase it needs to be demonstrated that the actions have been successfully completed. A “gatekeeper” is designated for each of the gates. This phased approach to projects is used extensively in the industry and represents best practice.

Condition Assessment is a key tool in the development of NLH's Asset Management plans. Its condition assessment program includes detailed assessments using the principles and stages of power generation facility condition assessment developed by EPRI. Programs developed by EPRI are generally considered to represent industry best practice.

AMEC<sup>295</sup> has reviewed NLH's Asset Management program, including specifically addressing several aspects:

- Asset Management Strategy and Practices

---

<sup>295</sup> Newfoundland and Labrador Hydro - Asset Management Strategy and Practices, AMEC's Report March 20, 2014

- Long Term Asset Management Plans (1,5, and 20 Year Plans)
- Asset Criticality and Critical Spares Strategy
- Maintenance Execution
- Councils of Experts

AMEC affirmed that “NLH strives to follow a structured approach to Asset Management with Condition Assessment as the foundation for the development, ongoing care, and renewal of its installed asset base” and NLH's asset management approach is essentially consistent with best electric industry practices such as the Electric Power Research Institute's (EPRI) condition assessment process for large generation facilities.

The key findings/recommendations of AMEC and their status where applicable include:

- *NLH's asset replacement/refurbishment activities for older breakers, disconnects, and transformers have been ongoing for several years and extend for many more. Given there were some issues with older breakers during the January 2014 outage incident, the scope and timing of the program should be reviewed in early 2014.*
- *NLH's new Execution Work Plan program has been well demonstrated in 2013 in other business lines. To improve resource utilization and effectiveness and outage management, its planned extension to replace existing Execution Work Plan processes at other NLH facilities in 2014 is recommended.*
- *NLH critical spares tracking/management until 2011 has been done primarily on a local facility basis reflecting experience, condition assessments, and vendor recommendations, constantly evolving over past years and decades, and continues to do so. After an initial three year development and assessment period beginning in 2011, a comprehensive pilot to the equipment level at Holyrood in 2013 of NLH's asset criticality and critical spares tracking management plans provided valuable feedback at an initial "Lessons Learned" assessment that was undertaken January 30, 2014. This should be followed up on, as is NLH's plan, in early 2014 following the work on the January 2014 incident. This will move the process towards a more comprehensive and cost effective approach consistent with industry practice and addressing critical issues before winter 2014-15 as a part of the overall asset management program for the winter of 2014/15.*
- *NLH has significant technical capability and staff, and has introduced a "Council of Experts" concept to enhance its best technology/technical practices adoption capabilities. It should, as is planned, continue to cost effectively utilize and enhance those groups and look for additional opportunities to enhance its best technology/technical practices capabilities.*
- *A more rigorous winter readiness program should be introduced, largely driven by internal self-assessment with appropriate external support/review. An internal winter readiness self-assessment guide has been drafted and 2014 plans include a more rigorous winter readiness program, building on the self-assessment results and 2013 process/facilities review work.*

- *NLH's O&M at Holyrood has not been impacted since the sanction of Muskrat Falls. Condition assessments on critical systems (i.e. re: safety, reliability) have continued. Capital and major operations projects in Holyrood's long term asset management plan are consistent with the station's end of life plans and required to ensure safe, reliable and environmentally sustainable operation have not been impacted. Those not critical for the period to end of generation service in about 2020 have not been approved, and should not impact availability to then.*

AMEC's review is considered detailed and comprehensive and it is expected that NLH shall implement all the recommendations given above. NLH has an asset inventory management system in place within its JD Edwards (JDE) system. Within this system, all of physical assets are uniquely identified with asset record numbers and their associated files. Asset records are linked to purchase cost, net book value, nameplate data, etc, as well as maintenance work orders, maintenance work order history, project management routines, etc. Records for asset systems, major and minor assets, are hierarchically arranged, using standard templates for hydroelectric units, thermal units, transmission lines, etc. Asset records are the backbone for linking asset information across the suite of JDE modules. Open work orders and work order history, as well as PM routines, and relevant cost data are all linked to the unique asset records. Asset records are retired as the associated physical assets are retired, with new asset records created for new assets construction or purchased.

Formal asset criticality analysis is used along with asset condition assessments as well and inspection and monitoring data to ultimately identify and schedule maintenance, refurbishment, upgrade, or replacement work. Identification of this work is the primary accountability of the Long Term Asset Planning function. People in these roles evaluate the data and prioritize the required work based on asset criticality and condition, in the context of customer service requirements. The necessary work is recorded in NLH's 1/5/20 year projects plans, spreadsheet based, or as maintenance work orders in JDE, whichever is appropriate at the time. The work required to be executed within a given year is captured and broken down into monthly/weekly schedules then executed via the annual work plan campaign process. As work is executed the status of associated work orders is updated inside of JDE, and in the annual work plan Gantt charts.

The Long Term Asset Planning function has assigned accountability for the asset hierarchy, asset criticality ranking, asset condition, and the analysis of this data into executable pieces of work. This analysis is performed outside of JDE.

NLH has initiated a Corporate Systems project this year aligned with a planned upgrade of JDE which includes evaluation of additional integration opportunities with new software.

### **10.3.2 NP**

#### **Generation Asset Management Practices**

NP operates 32 hydro generators in 23 small hydro plants and 5 thermal plants. All preventative maintenance and inspections as well as deficiency identification and corrective maintenance activities for hydro and thermal plants are recorded in the Company's computerized maintenance management system Avantis.

Preventative maintenance activities are completed by plant operators, maintenance staff, engineering staff, and consultants or a combination of same depending on the activity being performed. The responsibility of scheduling preventative maintenance activities lies with the planner. It is the planner's responsibility to ensure the appropriate personnel are assigned to ensure that the work is completed in the specified timelines. If a deficiency is identified and is considered to be an emergency, the Superintendent of Generation Operations is immediately notified.

Corrective maintenance activities are identified through preventative maintenance inspections and through normal day to day plant operations. Priorities are assigned to each deficiency to establish when corrective action is required. The assignment of priorities is based on engineering judgment and is done by experienced staff to ensure consistency in priority assignment.

The Superintendent of Generation Operations and the maintenance supervisors are responsible to ensure that all corrective maintenance is completed within the timelines as outlined in the asset management program. Guidelines for the inspection and maintenance of generating facilities are included in the Plant Operating Guidelines.

### **Generation Capital Refurbishment Programs**

The performance of NP's electrical system is largely a function of the condition of electrical system assets. For this reason, the leading justification for annual capital budget expenditures is the refurbishment of existing in-service assets. Approximately 50% of NP's overall annual capital expenditures are directed at plant replacement. Generation capital refurbishment programs involve considerable capital expenditures on an annual basis as in-service assets deteriorate with age and service.

### **Management of Maintenance and Refurbishment Programs**

NP plans its maintenance and refurbishment work on generating assets to minimize generation outages during the December 1<sup>st</sup> to March 31<sup>st</sup> winter season. The Company also takes action to minimize extended outage durations should unexpected delays occur in restoring the plant to service. These efforts minimize extended outage durations and help ensure NP's generation assets are available on the Island Interconnected System when most needed.

The Superintendent of Generation Operations and Superintendent of Engineering are responsible to ensure that all generation maintenance and refurbishment work is completed within the appropriate timelines. There are no specific guidelines for remedial work in case a generation facility could not be brought back to service on the planned schedule.

If planned maintenance or refurbishments are anticipated to extend past the original schedule or if an unplanned outage occurs, NP will take action to expedite the work to return the plant to service. These actions include (i) rescheduling non-essential work to be completed after the upcoming winter season, (ii) adding additional contractor resources, or (iii) working extended hours to bring the project back on schedule.



## 11. System Operations

In essence, system operations involves meeting the ever changing requirements of electricity customers with the highest level of reliability utilizing the combination of available generation and power delivery resources that provides service safely and in the most cost effective manner. The forecasting, investment planning and asset management activities described in previous sections are all directed at allowing system operations to constantly satisfy customer requirements.

As shown in Section 2.2 customer requirements are highly variable. During the winter months load is typically high and due to the high saturation of electric heating very temperature dependent. Peak load has exceeded 1,700 MW on the IIS and on peak days the load variation during a 24-hour period can be about 400 MW. However, in the summer months load is much lower and on the lowest load day in 2014 peak load on the IIS was just under 650 MW with the overnight load as low as 400 MW.

Until Muskrat Falls comes on line in 2018, the Holyrood thermal station will continue to be a critical source of generation on the Island. As noted in NLH's application for its 2015 capital budget, NLH projects that Holyrood will be called on to provide 1,600 to 1,850 GWh per year in the period 2015-2017 and that under critical dry weather conditions it could be required to contribute up to 3,000 GWh per year.

Once Muskrat Falls is commissioned and in full service, it will be capable of producing an average of close to 4,900 GWh per year<sup>296</sup> and under the Power Purchase Agreement between NLH and Muskrat Falls Corporation dated November 29, 2013, Base Block Energy will start at approximately 2,000 GWh in 2019 and increase over time.<sup>297</sup> Based on this agreement, NLH is planning to retire Holyrood from power generation duty after 2021.

The above figures reflect annual values; while the annual capacity factor of MF is expected to be in the 65% range, information was not available on any monthly variations in generation capability. While MF will eliminate the dependence on the aging thermal generation at Holyrood, system operations will need to adapt to the factors associated with the supply and delivery of this power source. Plans are well underway for this and will fit into the current system operations program as described below.

### 11.1 Operations Planning

On an annual basis, NLH prepares a generation plan including a generation outage schedule, which outlines the generating units' (hydroelectric and thermal) maintenance requirements and the outage times associated with each generating unit. NLH develops this schedule using the N-1 reserve criteria. Essentially, NLH ensures there is enough reserve available to cover the trip of the largest online unit. To determine if there is enough N-1 reserve available, the load forecast for each week

---

<sup>296</sup> [http://www.gov.nl.ca/lowerchurchillproject/backgrounder\\_7.htm](http://www.gov.nl.ca/lowerchurchillproject/backgrounder_7.htm)

<sup>297</sup> As discussed earlier, Nalcor has committed to deliver the Nova Scotia Block to Nova Scotia Power, which will reduce the amount of energy available to Newfoundland and Labrador for the initial 35 years of the project.

of the year is input into the schedule. This load forecast is provided by the System Planning Department.

On a shorter term basis (day to day, week to week), the System Operations Department will review any additional outage requests for generating units, other than those identified in the generation outage schedule, and either approve or reject the request. The same N-1 criteria are used in this decision making. However, the short term load forecasting application, Nostradamus, is used to determine the load forecast during the requested outage time.

In addition to the above, each operating day, the ECC maintains a minimum spinning reserve equal to 70 MW. This is required to cover performance uncertainties in generating units, especially wind and other variable generation and unanticipated increases in demand. As described in Section 7.3.3, NLH calculates available generation reserve for each day and takes necessary actions when it falls below the predefined levels.

## **11.2 Operations Planning – Planned System Equipment Outages**

To adequately plan the operation of the power system, it is necessary to have sufficient time to plan equipment outages and evaluate the effect of these equipment outages on system operation and customer service. Equipment outages on NLH's system can affect customers on NP's system and vice versa. Therefore adequate time for co-ordination between NLH and NP's control centres must be provided. The following procedure for outage request and approval are excerpted from NLH's Instruction No. 010, which we believe follows best practices.

### **11.2.1 Outage Request**

- a) Planned system equipment outages must be requested from the ECC as far in advance as possible
  - i) A minimum of FIVE WORKING DAYS notice shall be given for equipment outages which are internal to NLH (i.e., do not require customer outages)
  - ii) For outages involving NP, Industrial Customers and NLH Rural customers, a minimum of SEVEN WORKING DAYS notice is required
- b) The equipment outage is to be requested using the Planned System Equipment outage database application
- c) Requests for equipment outages shall originate from
  - i) Short Term Work Planning and Scheduling – Planner (Transmission and Rural Operations “TRO” Regions)
  - ii) Short Term Work Planning and Scheduling – Planner (Hydro)
  - iii) Short Term Work Planning and Scheduling – Planner (Thermal)
  - iv) Short Term Work Planning and Scheduling – Planner (Exploits)

- v) Other departments shall direct their equipment outage requests through the appropriate planning areas
- vi) NP Control Centre – Superintendent (or designate)
- d) All requests shall be made to the Supervisor - ECC (or designate) with copies sent to stakeholders
- e) Equipment outages requested by TRO shall contain the following information:
  - i) specific equipment affected (in case of transmission line indicate specific section)
  - ii) starting date and time\*
  - iii) ending date and time\*
  - iv) type of work protection required
  - v) purpose of equipment outage
  - vi) switching arrangements
  - \* The starting and ending times will include switching time and work time. This is especially important when customer interruptions are involved.
- f) Equipment outages requested by NLH Operations, Thermal Operations or Exploits Generation shall contain the following information:
  - i) equipment affected
  - ii) starting date and time\*
  - iii) ending date and time\*
  - iv) purpose of equipment outage
  - \* The starting time is the time the equipment is disconnected from the system. The ending time is the time the unit is restored to available status.
- g) Equipment outage notification by NP shall contain the following information:
  - i) specific equipment affected
  - ii) starting date and time\*
  - iii) ending date and time\*
  - iv) condition guarantee (if required)
  - v) purpose of equipment outage
  - vi) switching arrangements
- h) Other equipment outage requests, from CF(L)Co, NUGs, Industrial Customer, etc. will be channelled through the Supervisor - ECC, ( or designate) who will discuss the requirements with the area concerned before the request is granted

- i) When a decision has been made, the Supervisor, ECC (or designate) will notify the originator of the equipment outage request with copies to the same personnel as in the original request and to other stakeholders
- j) Switching arrangements shall be confirmed at the time of the equipment outage confirmation
- k) The equipment outage confirmation will be given as much advance notice as possible
- l) If there is a requirement for an equipment outage to be extended the ECC Shift Supervisor shall be advised

### **11.2.2 Outage Approval**

Prior to the approval of any planned equipment outages, the Planned System Equipment Checklist is to be completed by the Supervisor –ECC (or designate). To assist with the checklist, the document - System Constraints for Planned Equipment Outages should be reviewed. This document provides guidelines, constraints and other considerations when approving outages to power system equipment.

### **11.2.3 Deviation from Standard**

All parties shall attempt to work within the time limits as outlined in this standard. Timeframes may be relaxed through discussion and agreement between all stakeholders.

### **11.2.4 Forced Removal of Equipment**

Non-scheduled removal of equipment from service shall be determined by the ECC Shift Supervisor in consultation with available personnel or system on-call.

In case of an emergency, when time limitations prohibit consultation, the ECC Shift Supervisor shall exercise proper judgment and report the problem and action taken to appropriate personnel or on-call as soon as possible.

### **11.2.5 Preparation for Winter Readiness**

As per NLH's experience on preparation of generating units for winter readiness, the planned outage duration of generating units was sometimes extended, i.e. the maintenance work could not be fully completed before December 1 and not all units were ready for service before this date.

As the system load during the summer season is relatively low and it is always difficult to ensure all generation being ready for service starting from December 1, it may be appropriate to extend the "No Maintenance Window" by one half month or one month. This means that all planned maintenance should be completed before November 15 or November 1. It is noted that before completion of the Muskrat Falls project, the system still requires the thermal units to maintain system reliability and these units are not as reliable as combustion turbines and hydro plants,

maintenance of these units should be assigned with high priority and extra time should be allowed when possible.

Overlapping of planned maintenance of two or more major generating units is not allowed in the practice of many utilities. This may not be applicable to NLH as it has low load demand in the summer months and a high proportion of hydro generation capacity which usually has more energy available in the summer months.

### **11.3 Generation Dispatch**

As per the current practice, NLH follows the guideline below to maintain sufficient spinning reserves, maintain the reliability of the IIS and minimize service impacts to customers.

#### **Normal Sequence**

- 1) Place in service all of NLH's available hydroelectric generation
- 2) Request NP to maximize their hydroelectric generation
- 3) Make a Capacity Request of Deer Lake Power to maximize their hydroelectric generation
- 4) Request Non-Utility Generators to maximize their generation
- 5) Maximize Holyrood thermal generation
- 6) Start and load standby generators, both NLH and NP's units, in order of increasing average energy production cost with due consideration for unit start-up time. It is important to notify customers taking non-firm power and energy that if they continue to take non-firm power, the energy will be charged at higher standby generation rates

#### **Load Reduction**

- 7) Cancel all non-firm power delivery to customers and ensure all industrial customers are within contract limits
- 8) Inform NP of NLH's need to reduce supply voltage at Hardwoods and Oxen Pond and other delivery points to minimum levels to facilitate load reduction. Implement voltage reduction
- 9) Request NP to implement voltage reduction on their system
- 10) Request NP to curtail any interruptible loads (typically up to 10 MW and can take up to 2 hours to implement)
- 11) Request Corner Brook Pulp and Paper and or Vale Newfoundland & Labrador Limited for Capacity Assistance Request industrial customers to shed non-essential loads, informing them of system conditions

#### **Rotating Outages**

If the spinning reserves continue to decrease below the minimum level, the system frequency should be watched closely. In order to minimize outages to customers, utilize the reserves as much as possible and maintain the system frequency at 59.8 Hz.

- 12) Request NP to shed load by rotating feeder interruptions. At the same time, shed load by rotating feeder interruptions in NLH's rural distribution areas. Follow instruction in T-042 for rotating outages

Prior to implementing rotating power outages, the distribution feeder list will be reviewed for accuracy and will be further prioritized to minimize impact of feeder rotation to critical customers. Critical customers included, but were not limited to, hospitals, fire and police stations, seniors' homes, and water pumping stations. NP's primary criteria for designating critical customers focus on roles which are essential to the health, safety and welfare of the communities the Company serves. These roles are critical in times of distress such as major electrical system failures. These criteria for designation of critical customers are broadly consistent with both common sense and existing public utility practice. NP has never submitted its list of critical customers to the PUB for approval. However, the PUB routinely reviews the Company's response to major electrical system events, including how service to customers is restored.

#### **11.4 Daily Operation Coordination**

NLH is responsible for managing generation resources in order to meet the IIS demand. NLH coordinates this with NP.

NLH's ECC operates an energy management system that monitors and controls NLH's generation and bulk transmission systems. The ECC's primary functions are the economic dispatch of generation and ensuring the balance of electrical system supply and demand for the IIS. The Nostradamus load forecasting system is an integral part of the procedures. This system updates the short-term load forecast every hour. Following the system outages in January 2014 NLH took steps to improve the accuracy of the short-term load forecasts and it now reports to the PUB monthly on the accuracy during the previous month and is evaluating alternatives to achieve greater accuracy in the future. NP's System Control Centre (SCC), operates a supervisory control and data acquisition system that monitors and controls NP's generation, transmission and distribution systems. Both NLH's ECC and NP's SCC are staffed 24 hours a day, every day of the year.

The energy management system in NLH's ECC is linked to the supervisory control and data acquisition system in NP's SCC. This link provides each utility with near real time information concerning each other's electrical operations on the IIS. Data that is shared between the two utilities include individual generating unit output levels, the system demand and the system frequency. Communication and coordination between NLH's ECC and NP's SCC is continuous and is the central feature of daily operational coordination on the IIS.

NLH's ECC and NP's SCC ensure that routine daily electrical system operations such as generation dispatch and line and equipment switching are performed on a safe and reliable basis.

#### **11.5 Demand Response Program**

As indicated above, a demand response program is available to assist NLH balance system load and resources. The following levels of demand response can be called upon when needed:

1. CBPP – up to 60 MW in blocks of 20, 40 and 60 MW; under a second agreement there is an additional 30 MW of demand response that is available
2. Vale Newfoundland & Labrador – 15.8 MW
3. NP – various customers 10 MW

Agreements are in place with CBPP and Vale for items 1 and 2 above. These agreements require 20 minutes notice prior to the time the demand response, referred to as Capacity Assistance, is scheduled to begin. These agreements also have limitations on the number of requests per day, the number of requests per winter, the duration of each request and the total duration of capacity assistance in a winter.

Based on a system peak of 1,700 MW these agreements provide for total capacity assistance of approximately 7% of the peak demand. While this is a relatively small amount in absolute terms, it could be very significant under certain system conditions. This approach with large industrial customers is considered a best practice given the generation resource constraints that the system has been facing (and is expected to prevail until Muskrat Falls and the Labrador-Island Link are in service) and provides a low cost source of reserves even when there aren't impeding capacity resource constraints. Other utilities that face sharp weather related peak loads have provided incentives to smaller customers to allow their weather dependent loads (such as air conditioning where the system is summer peaking) to cycle on and off for short periods of time under critical system conditions. Given the importance of electric heating to NLH's system peak, such a program may be attractive. We assume that it will be evaluated in the ongoing review of DSM measures being performed by NLH and NP.

## **11.6 Response to Emergency Conditions**

### **11.6.1 NLH**

The parent company of NLH, Nalcor has updated its Corporate Emergency Response Plan (CERP)<sup>298</sup> procedures and assignments of responsibilities to individuals in Nalcor corporate management relating to corporate support services during emergencies. By utilizing the procedures within the CERP, these individuals will be able to (a) effectively mobilize corporate response to emergency situations and (b) execute all necessary corporate emergency support actions.

The CERP provides clear and concise guidance for Emergency Support actions to be taken under all emergency scenarios that could reasonably be expected to occur within Nalcor. An emergency is defined as any unexpected occurrence either resulting in (or having the likely potential to result) in death, serious injury (or illness) requiring hospitalization, environmental impact posing a serious threat to on-scene personnel or wildlife, major and significant damage to Nalcor or other property, or significant public impact. The response to such incidents requires immediate notification and action.

---

<sup>298</sup> Corporate Emergency Response Plan, Version 1.6, Nalcor Energy, November 21, 2013.

Examples include:

- a) An Incident which results in, or could result in, loss of life or a serious injury (e.g. vehicle collisions, lost personnel, etc.)
- b) Explosions or major fires
- c) Loss of power system equipment that results in significant supply interruption that could exceed the Maximum Acceptable Downtime
- d) Well control incidents
- e) Hydrocarbon or chemical spills
- f) Loss of or damage to helicopters or fixed wing aircraft
- g) Hazards posing an imminent threat to the operating area such as heavy weather
- h) Major or significant damage to equipment not caused by any of the above (e.g. materials handling equipment failure)
- i) Security related incidents involving issues such as extortion, bomb threats or acts of terrorism

In the event of an emergency, the CERP also provides procedures to ensure the Corporate Emergency Operations Centre (CEOC) can be quickly activated should the facility experiencing the emergency require additional support (technical, media, family, regulatory liaison, logistics, etc.).

As a matter of policy, Nalcor will make a copy of the CERP available to each person and / or organization involved in the emergency response and / or emergency management process.

In the event that a severe weather event is forecasted or there is a system problem that affects NLH's ability to meet system load, NLH's ECC issues an advisory to field operations staff concerning the adverse weather or potential generation shortfall and prepares for the event.

For potential generation shortfall, NLH ensures that staff is dispatched to certain remote hydro plants and standby generation locations. In addition, in the case of a severe weather event, NLH's response includes any or all of the following activities, depending on the expected severity of the event:

- Pre-event coordination call to coordinate response activities
- Enhanced staffing levels at ECC and other control rooms as needed
- Deployment of work crews to reduce response time in the event of an unplanned outage or equipment problems
- Additional inspections of equipment and vehicles (four wheel drive trucks, snowmobiles, ATVs and specialized vehicles) to ensure full functionality and full gas tanks



- Additional communication with on-call personnel to ensure readiness to respond if needed
- Scheduling of additional snow removal to ensure ongoing access to critical infrastructure during storm events
- Test run of standby diesels and gas turbines

### **11.6.2 NP**

NP expects that throughout the year the need may arise to respond to severe weather or system events that have the potential to disrupt service to customers. When a severe weather event is expected, adjustments to routine operations are made to ensure the Company is prepared to respond quickly and effectively should customer outages occur.

To assist in preparing for response to an anticipated severe weather event a storm preparation checklist has been developed. This checklist is maintained on the Company's Intranet and is available to all employees. The checklist is reviewed regularly and additions or deletions made as appropriate.

The nature and extent of the preparations made by NP in anticipation of a severe weather event will vary depending on the weather forecast and the experience elsewhere as the storm moves towards the Province. Preparations for system problems affecting NP's ability to meet customers' load would be initiated following discussions with NLH regarding any anticipated shortfall in supply to NP caused by either loss of generation, transmission line capacity and/or failure of terminal station equipment.

Preparations for a severe weather event would typically start 2 days prior to the forecast event. Preparations for a system event would start immediately when NP is advised by NLH of the event occurring or potentially occurring. The Manager of Operations is the primary person responsible for monitoring weather conditions and liaising with NLH. When a significant event has been identified the Manager of Operations will advise the Executive and the other operations managers to initiate preparations to ensure the Company responds appropriately. This arrangement is considered to be in accordance with best utility practices.

## 12. Conclusions

As a largely isolated electricity system, electricity supply planning standards and operating practices in Newfoundland and Labrador in a number of areas are different than those of most other electric utilities in North America. These other electric utilities have interconnections with adjacent systems which can be relied upon to provide power during low probability events such as multiple generator or transmission line outages and extreme weather. This allows these interconnected systems to achieve higher reliability levels at a lower cost.

The development of the Muskrat Falls Project and associated transmission facilities will fundamentally change the way that Newfoundland and Labrador's electricity system operates. For the first time Newfoundland and Labrador will be electrically interconnected allowing: (1) electricity surpluses between what were previously two independent systems to be shared; (2) electricity that is surplus to the province to be sold into the Maritimes and US Northeast over the Maritime Link at market-based prices. Initially, this could represent about 40% of the output of Muskrat Falls; (3) the high cost oil-fired and polluting Holyrood generating station to be retired as a producer of power; and (4) reliability standards that drive investment in the province and influence the quality of service that customers receive to be reassessed. At this time about 98% of the province's electricity will be from renewable energy resources whose costs are largely fixed, with costs to customers generally declining over time as the facilities' capital costs are paid for.

To fully capitalize on these opportunities it is important that the province's electricity sector be organized and operated efficiently and provide an appropriate balance between reliability and affordability. To this end the Department engaged Power Advisory to identify best practices that may be relevant to Newfoundland and Labrador's electricity sector.

Of particular relevance to the province's electricity sector is the experience of other predominately hydroelectric provinces in managing their hydroelectric resources for the benefit of customers. Interestingly, these provinces have among the lowest electricity rates in Canada, an indication of the long-term benefits offered by major hydroelectric projects such as Muskrat Falls. Hydro-Québec's experience is perhaps the most relevant for Newfoundland and Labrador given that it also has large hydroelectric reservoirs and operates in many of the same markets that will be available to Nalcor.

With direct interconnections to a number of competitive power markets, which have volatile hourly electricity prices, Hydro-Québec often engages in short-term buy-sell transactions where electricity from these markets is purchased when power prices are low. This energy can then be stored in the reservoirs and resold when power prices are high. Hydro-Québec has a "Heritage Contract" which guarantees its customers the benefits of low cost hydroelectric generation for a fixed block of power. The supply of customer requirements beyond this block are subject to a market-test, where Hydro-Québec Production bids on the right to provide such incremental energy requirements in competition with other providers. The net effect is that customers are protected from the risks of

new generation developments, but are guaranteed the benefits of low cost generation that was built specifically to serve them.

The strength of Hydro-Québec's balance sheet allows such a model to be employed in Québec. Without the same financial capability, fewer markets in which to participate and lower price volatility in these markets, Manitoba Hydro depends more on long-term energy contracts where the risks and benefits are shared with customers. Nalcor's approach in its export markets will need to consider its resource portfolio, the amount of energy and capacity available for export, market access alternatives, and customer requirements in the province and in its export markets.

The direct interconnection of Newfoundland and Labrador to the North American grid raises a series of issues regarding appropriate reliability standards for the province's electricity system, transmission service and tariffs, and the overall organization of the electricity sector. Nalcor's participation in export markets requires that various minimum standards need to be considered when designing these transmission tariffs and establishing a system operator function. The importance of market access to the successful development of the Gull Island hydroelectric project underscores the importance of these issues.

One area which is often problematic for Crown utilities such as NLH is regulatory oversight. Crown utilities generally have a role in implementing broad public policy objectives (e.g., development of major infrastructure projects that have broad-based benefits that go well beyond the electricity sector) such that traditional cost-of-service rate-base regulation can be complicated. NLH's experience is not an exception. The fact that one decision of the PUB with respect to the Rate Stabilization Plan has been remanded and another overturned suggests that the PUB cannot be viewed as providing desired regulatory stability and certainty in its oversight of NLH. Interestingly, the PUB's oversight of NP is more effective and appears to provide regulatory predictability and certainty, most likely reflecting a simpler relationship and operations that are better suited to such regulation.

Another regulatory issue is the Rural Subsidy, which results in rates below costs for customers on the province's isolated systems. The Rural Subsidy adds considerable complexity to the ratemaking process and results in significant cross-subsidies among different customer groups. The total cost of the Rural Subsidy has increased significantly overtime and now represents about 8% of NP customers' costs.<sup>299</sup> Furthermore, with the subsidy available beyond the lifeline block it sends a poor price signal regarding the value and cost of that additional energy.

---

<sup>299</sup> 2013 NLH General Rate Application, PUB-NLH-081 (Revision 1, Nov 20-14)

## Appendix A: Glossary

**Bioenergy:** Energy produced from living or recently living plants or animal sources. Sources for bioenergy generation can include agricultural residues, food process by-products, animal manure, waste wood and kitchen waste.

**Capacity:** The maximum output of electricity a generating unit is providing at one point in time, typically measured in watts, kilowatts, and megawatts.

**Demand:** The rate at which electricity is delivered to or by a system at a given point in time, usually expressed in kilowatts or megawatts.

**Demand Side Management:** The modification of consumer demand through the use of energy efficiency and demand response rate.

**Distribution:** A distribution system carries electricity from the transmission system and delivers it to consumers. Typically, the network would include medium-voltage power lines, substations and pole-mounted transformers, low-voltage distribution wiring and electricity meters.

**Electricity:** A manufactured form of energy, as opposed to naturally occurring energy resources, such as coal, oil or natural gas. On a large scale, electricity is produced by rotating machines (generators) which operate on the principle that an electric current is generated whenever a conductor moves through a magnetic field.

**Energy:** The amount of electricity produced over a period of time, typically measured in watt-hours, kilowatt-hours, or megawatt-hours.

**Federal Energy Regulatory Commission:** The United States independent agency that regulates the interstate transmission of electricity, natural gas, and oil.

**Generation:** The process of converting thermal, mechanical, chemical or nuclear energy into electric energy.

**Grid:** A network of electricity power lines and connections.

**Hydroelectric Generation:** Generating electricity by harnessing mechanical energy from running water.

**Independent Power Producers:** Refers to a producer of electrical energy which is not a public utility but which makes electric energy available for sale to utilities or the general public.

**Integrated Resource Plan:** A utility plan for meeting forecasted annual peak and energy demand, plus some established reserve margin, through a combination of supply-side and demand-side resources over a specified future period.

**Installed Capacity:** The maximum capacity that a generating unit, plant or system is designed to run at under ideal conditions.

**Interconnected System:** Two or more individual transmission systems that have one or more interconnecting lines.

**Isolated System:** An electricity system that is not electrically connected to any other electricity system.

**Kilowatt (kW):** A standard unit of power that is equal to 1,000 watts (W). Ten 100-watt light bulbs operated together require one kW of power.

**Kilowatt-hour (kWh):** A measure of energy production or consumption over time. Ten 100-watt light bulbs, operated together for one hour, consume one kWh of energy.

**Megawatt (MW):** A unit of power equal to 1,000 kilowatts (kW) or one million watts (W).

**Megawatt-hour (MWh):** A measure of energy production or consumption over time: a one MW generator, operating for 24 hours, generates 24 MWh of energy.

**Memorandum of Agreement:** A document that provides written understanding of the agreement between parties.

**Memorandum of Understanding:** A document that describes a bilateral or multilateral agreement between two or more parties.

**Mid-continent Area Power Pool:** An association of electric utilities and other electric industry participants operating in all or parts of Iowa, Minnesota, Montana, North Dakota, and South Dakota.

**Midwest Reliability Organization:** Successor to the Mid-continent Area Power Pool.

**Non-Utility Generator:** An entity, which is not a public utility, but which owns facilities to generate electric power for sale to utilities and end users.

**North American Electric Reliability Corporation:** A not-for-profit international regulatory authority whose mission is to assure the reliability of the bulk power system in North America.

**Northeast Power Coordinating Council:** A not-for-profit corporation in the state of New York responsible for promoting and improving the reliability of the international, interconnected bulk power system in Northeastern North America.

**Peak:** The greatest demand on an electricity system during any prescribed period.

**Peak Demand:** The maximum power demand registered by a customer or a group of customers or a system in a stated period of time. The value may be the maximum instantaneous demand or more,

usually the average demand over a designated interval of time, such as one hour. Normally stated in kilowatt or megawatt.

**Power System:** The interconnected facilities of an electric utility. A power system includes the generation, transmission, distribution, and protective components necessary to provide service.

**Regional Transmission Organizations:** Non-profit, public-benefit corporations that were created as a part of electricity restructuring in the United States, beginning in the 1990s. RTO's are responsible for moving electricity over large interstate areas.

**Reliability Coordinator:** The entity that is the highest level of authority who is responsible for the reliable operation of the Bulk Electric System.

**Supply Mix:** The different types of fuel that are used to produce electricity in a particular jurisdiction. Typically, the mix is expressed in terms of the proportion of each type within the overall amount of energy produced.

**Terawatt-hour (TWh):** A unit of power equal to 1 billion kilowatt-hours.

**Thermal generation:** The production of electricity from plants that convert heat energy into electric energy. The heat in thermal plants can be produced from a number of sources such as coal, oil, gas or nuclear fuel.

**Transmission:** The movement of electricity, usually over long distance, from generation sites to consumers and local distribution systems. Transmission of electricity is done at high voltages. Transmission also applies to the long distance transportation of natural gas and oil.

**Voltage:** The electric force or potential that causes a current to flow in a circuit (just as pressure causes water to flow in a pipe).

**Watt:** The scientific unit of electric power

## Appendix B: Generation Asset Summary Table

System	Sub System	Asset Name	Owner	Fuel Type	Installed Capacity	Gross Continuous Unit Rating	In-Service Date	Annual Energy	Note
IIS	NLH assets	Holyrood - unit 1	NLH	Oil	170	170	1970	1,039	Reflects maximum annual energy for units
		Holyrood - unit 2	NLH	Oil	170	170	1971	1,039	Reflects maximum annual energy for units
		Holyrood - unit 3	NLH	Oil	150	150	1980	917	Reflects maximum annual energy for units
		Holyrood - diesel blackstart	NLH	Diesel	14.6		2015		
		Hardwoods	NLH	Gas-Diesel	50	50	1976		
		Stephenville	NLH	Gas-Diesel	50	50	1975		
		Holyrood - unit 4	NLH	Gas-Diesel	123.5		2014		
		Hawke's Bay - unit 547/548	NLH	Diesel	5		1971		
		St. Anthony	NLH	Diesel	9.7		1973-1982		
		Bay d'Espoir - unit 1	NLH	Hydro	76.5	76.5	1967	331	
		Bay d'Espoir - unit 2	NLH	Hydro	76.5	76.5	1967	331	
		Bay d'Espoir - unit 3	NLH	Hydro	76.5	76.5	1967	331	
		Bay d'Espoir - unit 4	NLH	Hydro	76.5	76.5	1968	331	
		Bay d'Espoir - unit 5	NLH	Hydro	76.5	76.5	1970	331	
		Bay d'Espoir - unit 6	NLH	Hydro	76.5	76.5	1970	331	
Bay d'Espoir - unit 7	NLH	Hydro	154.4	154	1977	663			
Cat Arm - unit 1	NLH	Hydro	68.5	67	1985	375			
Cat Arm - unit 2	NLH	Hydro	68.5	67	1985	375			





Customer Owned and Controlled Generation	NUGS	Lookout Brook	NP	Hydro	6.2	1945	
		Rose Blanche	NP	Hydro	6	1998	
		Greenhill Gas Turbine	NP	Gas	22	1975	
		Mobile Gas Turbine MGT	NP	Gas	7.2	1974	
		Port Aux Basques Diesel	NP	Diesel	2.5	1969	
		Portable Diesel MD3	NP	Diesel	2.5	2004	
		Wesleyville Gas Turbine	NP	Gas	14.7	1969	
		Corner Brook Pulp and Paper	Kruger	Hydro	99.1	1925	Generation available at 60 Hz
		Vale Capacity Assistance	Vale	Diesel	21.9	1925	Generation available at 50 Hz
		Fermeuse	Elemental Energy	Wind	27	2009	
St. Lawrence	ENEL North America Inc	Wind	27	2008			
Rattle Brook	Algonquin Power	Hydro	4	1998			
Corner Brook	Kruger	Biomass	15	2002			

System	Generating Station	Fuel	Capacity (MW)
LIS	Churchill Falls Twinco Volumes	Hydro	225
	Churchill Falls Recall Block	Hydro	300
	Happy Valley - Goose Bay	Diesel	27
	Mud Lake	Diesel	0.1

System	Sub System	Capacity (MW)
Newfoundland Isolated	Total	6.4
	Owned	27.3
	Purchased	4
Labrador Isolated	Total	31.3

## Appendix C: Electricity System Demand Summary Table

Owner	System	Description	Type	Units	1999	2000	2001	2002	2003	2004	2005	2006	2007	2008	2009	2010	2011	2012	2013	2014
NL	IIS	Calendar Peaks as supplied by NLH	Peak Demand	MWh	1,265	1,240	1,262	1,403	1,402	1,405	1,361	1,310	1,323	1,323	1,390	1,305	1,399	1,385	1,501	1,535
AL	IIS	Calendar Peaks as supplied by all producers	Peak Demand	MWh	1,465	1,443	1,435	1,592	1,595	1,598	1,595	1,517	1,540	1,520	1,601	1,478	1,544	1,550	1,651	1,714
NP	IIS	NP System Peak Demand	Peak Demand	MWh							1,167	1,131	1,142	1,181	1,219	1,206	1,166	1,241	1,281	1,336
NL	IIS	Annual Energy Requirements - Industrial Customers	Annual Energy	GWh				2,622	2,721	2,796	2,638	2,216	2,105	1,981	1,276	1,258	1,206	1,265	1,246	
NL	IIS	Annual Energy Requirements - Rural Customers	Annual Energy	GWh				403	397	395	382	372	400	412	415	406	438	446	458	
NP	IIS	Island System Load - Newfoundland Power	Annual Energy	GWh				5,025	5,045	5,125	5,121	5,043	5,371	5,415	5,535	5,480	5,787	5,750	6,049	
NL	IIS	NLH Bulk Transmission Losses	Annual Energy	GWh				167	176	179	177	207	182	196	196	210	221	226	243	
NL	IIS	Total Island System Load	Annual Energy	GWh				8,221	8,340	8,496	8,318	7,838	8,058	8,004	7,422	7,355	7,652	7,687	7,996	
NL	DIesel	Isolated Diesel System Annual Energy Requirements	Annual Energy	GWh								61	64	67	66	70	68	75		
NL	LIS	Labrador Annual Energy Requirements	Annual Energy	GWh								1,011	989	750	911	780	819	957		
NP	IIS	NP Actual Energy Sales	Annual Energy	GWh					4,882	4,979	5,004	4,995	5,093	5,208	5,299	5,419	5,553	5,680	5,763	

## Appendix D: Electricity System Reliability Metrics Table

Utility	Reliability Metric	2001	2002	2003	2004	2005	2006	2007	2008	2009	2010	2011	2012	2013
NLH	WCF - NLH	88.2	86	87.8	89.8	84.9	83.2	80.5	82.3	82	83.4	83.3	82.9	75.5
NLH	WCF CEA Avg (2003-2007, 2008-2012)			86.6 7	86.6 7	86.6 7	86.6 7	86.6 7	85.29	85.29	85.29	85.29	85.29	85.29
NLH	DAFOR - NLH	2.4	5.2	2.9	2.3	2.1	3.7	7.9	5	4.5	1.8	2.7	2.3	12.2
NLH	DAFOR CEA Avg (2003-2007, 2008-2012)			4.5	4.5	4.5	4.5	4.5	5.56	5.56	5.56	5.56	5.56	5.56
NLH	T-SAIDI - NLH	44	187	222	99	99	151	186	278	100	173	432	171	468
NLH	T-SAIDI CEA Avg (2008-2012)								85.79	85.79	85.79	85.79	85.79	85.79
NLH	T-SAIFI - NLH	1.4	2.3	2.6	1.8	1.5	1.6	2.8	1.7	0.9	2.3	4.5	1.9	3.5
NLH	T-SAIFI CEA Avg (2008-2012)								0.85	0.85	0.85	0.85	0.85	0.85
NLH	T-SARI - NLH	32	82	86	54	65	94	66	164	111	75	96	90	133.9
NLH	T-SARI CEA Avg (2008-2012)								100.4 5	100.4 5	100.4 5	100.4 5	100.4 5	100.4 5
NLH	SAIDI - NLH	10	14	12	11	9	8	8.7	11.2	9.4	6.6	16.3	8.3	18.6
NLH	SAIDI CEA Avg (2008-2012)								6.74	6.74	6.74	6.74	6.74	6.74
NLH	SAIFI - NLH	7.5	9.4	7.9	5.9	5.8	5.4	6.2	6.3	4.3	3.5	5.7	4.4	5.7
NLH	SAIFI CEA Avg (2008-2012)								2.73	2.73	2.73	2.73	2.73	2.73
NLH	UFLS	10	17	12	7	5	6	6	6	7	6	3	5	7
NP	SAIDI (excluding Significant Events)				4.9	3.5	3.0	3.2	2.8	2.7	3.0	2.8	3.6	9.5
NP	SAIDI (including Significant Events)				4.9	3.5	3.0	6.5	2.8	2.7	14.2	4.1	6.7	10.3
NP	SAIFI (excluding Significant Events)				3.6	3.2	2.9	3.0	2.8	2.5	1.8	1.9	2.6	3.5
NP	SAIFI (including Significant Events)				3.6	3.2	2.9	3.3	2.8	2.5	3.0	2.2	3.0	3.8

## Appendix E: Calculation of LOLP versus LOLH

Calculation of LOLP is based on daily peak load duration curve while calculation of LOLH is based on hourly load duration curve. A load duration curve (LDC) illustrates the variation of a certain load in a specified period (such as a day, a week, a month or a year) in a downward form such that the greatest load is plotted on the left and the smallest one on the right of the chart. On the time axis, the time duration for which each certain load continues during the specified period is given. It could also be understood that the LDC is an arrangement of all load levels within a specified period in a descending order or magnitude. In creation of daily peak load duration curves, each day is represented by one point only, i.e. the maximum hourly load in the day while in creation of hourly load duration curves; each day is represented by 24 hourly load values. Based on this description, it is not difficult to understand that for a given time period, its daily peak load duration curve would be located above its hourly load duration curve (if hourly load varies over the given period) or overlapped with its hourly load duration curve (if hourly load does not vary).

Figure E-1 shows an example daily peak load duration curve and an example hourly load duration curve.

Figure E-1: Daily Peak Load Duration Curve and Hourly Load Duration Curve

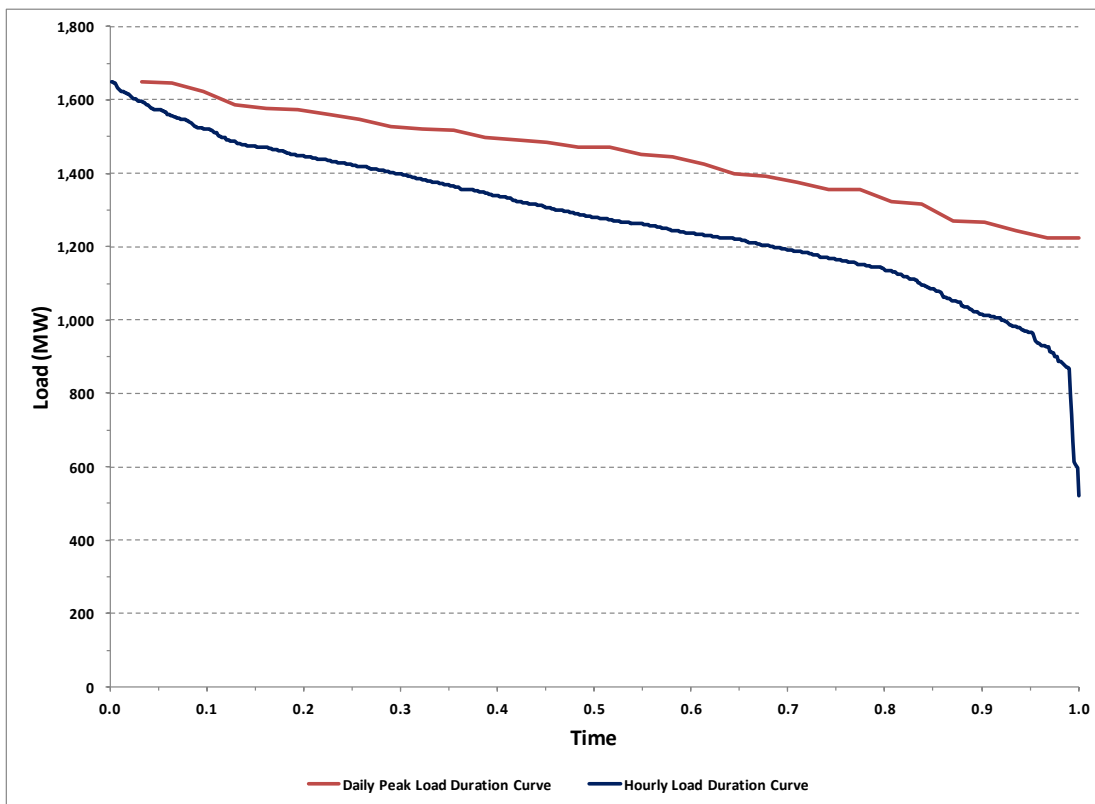

Based on the characterizations of daily peak load duration curves and hourly load duration curves above, for a given generation portfolio as well as a set of presumed parameters for generating units,

the calculated LOLP in days per year given its use of daily peak loads will be higher than the calculated LOLH in hours per year divided by 24 (conversion of the measurement unit from hours per year into days per year) as higher load demand is used in calculation of LOLP. One could then understand when the planning criterion of LOLP was switched to LOLH in 1997; a LOLH of 2.8 hours per year is equivalent to a LOLP of 0.2 day per year, instead of  $0.2 \times 24 = 4.8$  hours per year.

## Appendix F: Cost Comparison with Interruption Damage Cost

Figure F-1 shows three cost curves against the system reliability level, which are for utility cost, interruption damage cost and total cost. It is in general recognized by electric power industry that the higher the expected system reliability level is, the more a utility needs to invest and spend on its facilities and operations while the less damages its customers will suffer from supply interruptions. The utility cost includes all capital investment, O&M costs and GHG offset allowance costs when applicable. The interruption damage cost is the monetary losses electricity consumers suffer from power interruptions. As all costs incurred by a utility will eventually be paid by electricity customers, the total cost to the customers will be the sum of the utility cost and interruption damage cost. One of the essential purposes of generation planning is to find a cost effective point which falls in the potential least cost range as illustrated in Figure F-1. It is, however, possible that the estimated reliability level achieved at the potential least cost range could be lower than the established system operating requirements and/or customers' expectations even if customer interruption damage costs are considered in selection of reliability level. Without taking into account the customers' interruption damage cost, the expected reliability level would be determined by combination of system operational requirements, incremental utility cost and customers' expectations.

Figure F-1: Cost Comparison with Interruption Damage Cost

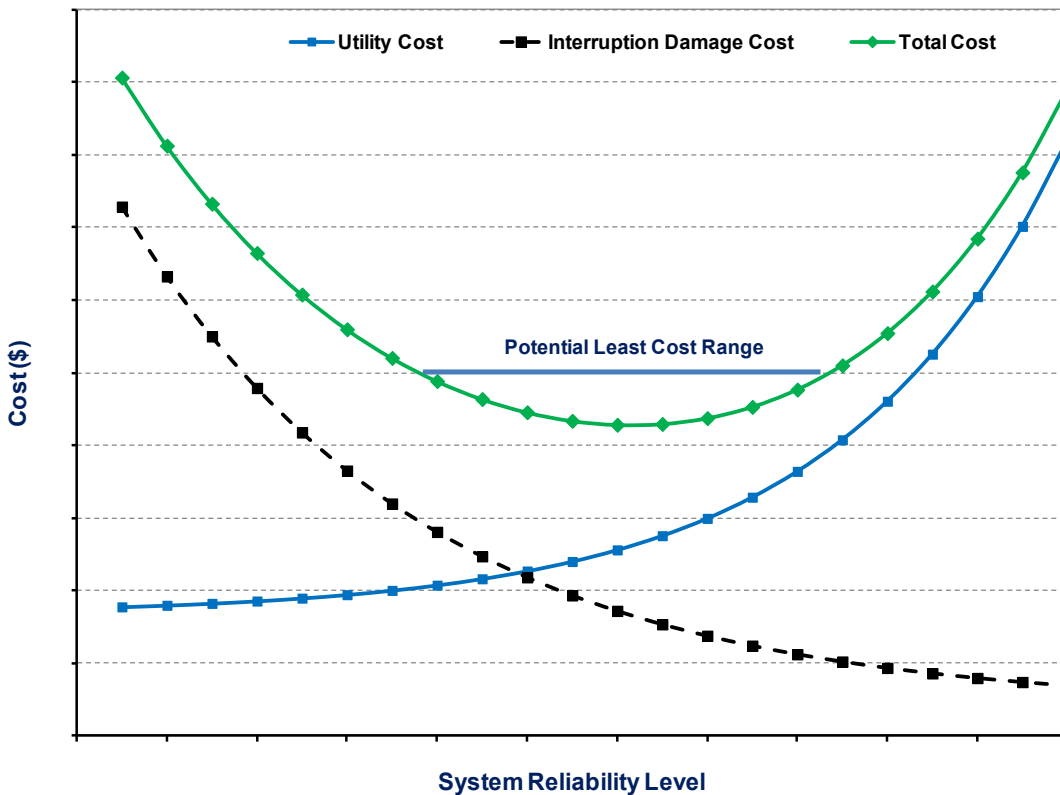

## Appendix G: Forced Outage Rates

Generation planning periodically confirms the resource adequacy of a system through detailed reliability simulations that convolve the expected load profiles and available generation fleet with specified forced outage rates, available energy and planned maintenance schedule to determine generation system LOLH values. A unit's contribution to resource adequacy is typically a function of the unit's capacity, available energy and its forced outage rate. Based on CEA's definition, the forced outage rate (FOR) of a generating unit within a given period of time is the ratio of total forced outage time to total forced outage time plus total operating time multiplied by 100, which is calculated using the following equation:

$$FOR = \frac{FO + FEMO + FEPO}{FO + FEMO + FEPO + O + O(FD) + O(SD)} \times 100$$

Where FO – the number of hours the generating unit was in a forced outage state

FEMO – the number of hours the generating unit was in a forced extension of

a maintenance outage state

FEPO – the number of hours the generating unit was in a forced extension of a planned outage state

O – the number of hours the generating unit was in the operating state

O (FD) – the number of hours the generating unit was operating under a forced derating state

O (SD) – the number of hours the generating unit was operating under a scheduled derating state

As FOR does not take into account the unavailability contributed by forced derating when a generating unit is in either operating state or available but not operating (ABNO) state, the term DAFOR (derated adjusted forced outage rate) is normally used in generation planning (instead of FOR), which is calculated using the following equation:

$$DAFOR = \frac{FO + FEMO + FEPO + O(FD)_{adj} + ABNO(FD)_{adj}}{FO + FEMO + FEPO + ABNO(FD)_{adj} + O + O(FD) + O(SD)} \times 100$$

Where FO – the number of hours the generating unit was in a forced outage state

FEMO – the number of hours the generating unit was in a forced extension of

a maintenance outage state

FEPO – the number of hours the generating unit was in a forced extension of a planned outage state

O (FD)<sub>adj</sub> – the number of equivalent outage hours the generating unit was operating under a forced derating state



ABNO (FD)<sub>adj</sub> – the number of equivalent outage hours the generating unit was in the available but not operating state

O – the number of hours the generating unit was in the operating state

O(FD) – the number of hours the generating unit was operating under a forced derating state

O (SD) – the number of hours the generating unit was operating under a scheduled derating state

It is noted that NERC<sup>300</sup> has defined more states for generating units and two terms, FOR and EFOR (equivalent forced outage rate) have been used to represent the forced outage probability but they are slightly different from the CEA's FOR and DAFOR.

### **Transmission and Distribution Outages**

For outages involving two or more transmission and distribution components, they can be categorized into the following four types<sup>301</sup>:

- i) Independent outages
- ii) Dependent outages
- iii) Common mode outages
- iv) Station originated outages

Independent outages are the easiest to deal with and involve two or more elements. They are referred to as overlapping or simultaneous independent outages. The probability of such an outage is the product of the failure probabilities for each of the elements.

Dependent outages are dependent on the occurrence of one or more other outages. An example is an independent outage of one line of a double circuit followed by the removal of the second line due to overload.

A common mode outage is an event having an external cause with multiple failure events where the events are not consequences of each other. The most obvious example of a common mode outage is the failure of a transmission tower supporting two or more transmission circuits. The outage probability caused by the common mode failure events could be much higher than that due to overlapping of the independent outages of the two lines.

The outage of two or more transmission elements not necessarily on the same right of way and/or generating units can arise due to station originated causes. Station originated outage can occur due to a ground fault on a breaker, a stuck breaker condition, a bus fault, etc., or a combination of these outages.

According to CEA, a Common Mode Outage is an event where more than one component forced outage results from a single primary cause and where the outages are not consequences of each other.

---

<sup>300</sup> North American Electric Reliability Corporation

<sup>301</sup> Reliability Evaluation of Power Systems, Roy Billinton and Ronald N Allan, Plenum Press, 1984

In accordance with the above definition, an obvious mode of failure would be the outage of two lines on the same tower. Another mode of failure is a bus fault resulting in outage of a number of system components.

The simultaneous loss of multiple generators at a single generating plant may be considered if there are common-mode failures that can affect multiple generators.

A three phase fault on two lines on adjacent towers (NERC Category C.5 contingency) is applied to a credible common mode contingency. However, the credibility of such a common mode failure needs to be carefully ascertained. Such a contingency may be the result of forest fire or lightning or even severe icing. Considerations in the determination of credibility should include line design; length; location, whether forested, agricultural, mountainous, etc.; outage history; operational guidelines; and separation between circuits. Similarly, a non-three phase fault with normal clearing on common mode contingency of two adjacent circuits on separate towers may be considered depending on the event frequency resulting in common mode outage. The same principle applies to LIL bi-pole block (NERC's C.4 contingency).

In view of the incidents that have occurred in January, 2013 and January, 2014, on the NLH system, examples of possible common mode failures in the future could be:

- Permanent outage of bi-pole,
- Breaker failure at Hardwoods and Oxen Pond

In the present day system, the severest single contingency experienced is the loss of a Holyrood unit. After the LIL enters service, it is planned to retire the existing units at Holyrood in 2021 and operate one of the units as a synchronous condenser. At this point the loss of a unit number 7 at Bay D'Espoir would have a similar impact.

Under N-1 conditions, the current transmission planning criteria requires that there is no loss of load for the loss of a transmission line or power transformer. However, it permits temporary under frequency load shedding for the loss of a generator. With LIL, the planning criteria will be more stringent so that no load-shedding will be required following the loss of the largest generator. In this respect, the LIL HVdc would improve the reliability of power supply to customers.

Given that each pole of LIL will have an overload capacity of 200% for 10 minutes and 150% for continuous operation, outage of a pole (N-1) is expected not to result in any load loss.

However, under N-2 conditions, the permanent bi-pole block results in a potential loss of up to 900 MW (of which some 170 MW could be taken by Emera over the ML and could be interrupted under the agreement with Emera), which is higher than the case of loss of two Holyrood units (340 MW) in the present day system. Also, an underlying assumption is that the under-frequency load shedding scheme is adequate in design to trip the required load in 'specified' time. A permanent bi-pole fault is a low probability but a credible event. The planning criteria allow load shedding in the event of a permanent bi-pole fault. An underlying requirement is that the under-frequency load shedding is minimized and the system remains intact.

## **Appendix H: Incremental Cost of a Higher Level of Reliability Criterion**

The “Generation and Reserve Planning” report prepared by NLH in March 2014 presents the following statement based on the Ventyx review report dated March 21, 2014:

Ventyx indicates that the standard industry practice is to apply a LOLP of 0.1 days per year, or “one day in ten years.” However, it should be noted that the 0.1 days per year standard applies to interconnected utilities. For true “stand alone” utilities, the cost to achieve a 0.1 days per year standard is often cost prohibitive. In 1977, NLH conducted a thorough analysis of system reserves and as a result recommended 0.2 days per year, or “one day in five years.” NLH justified the 0.2 days per year over 0.1 days per year, based on the economics of meeting the more stringent requirement. For impact comparison, the incremental present value revenue requirements necessary to move from a reliability index of 1.0 days per year to 0.2 days per year was approximately \$24 billion and the incremental present value revenue requirements necessary to move from a reliability index of 0.2 days per year to 0.1 days per year was approximately \$17 billion. Simply stated, the cost to move from a reliability index of 0.2 days per year to 0.1 days per year was 71% of the cost to move from a reliability index of 1.0 days per year to 0.2 days per year. Ventyx concluded NLH was justified in its decision to adopt a reliability index of 0.2 days per year at that time.

The estimated incremental present value of some \$17 billion when the LOLP index is raised from 0.2 days per year to 0.1 days per year is shown in both the NLH report and the Ventyx review report. Given this high level of incremental cost we checked the original report prepared in 1977 and found that the unit of million should be used in the report, instead of billion. This means that the estimated incremental cost was \$17 million (in 1977 PV) for the higher level LOLP. While we don’t know all the assumptions supporting the present value calculation, it seems that an amount of \$17 million could have been considered a reasonable investment to incur at that time to obtain the higher reliability level. However, in retrospect, looking back over the period 1977 to 2013, NLH’s system planning group noted that there would not have been any significant change in the level of generation outages if capacity planning had been based on the 0.1 day per year LOLP value. The first benefit from this would have been on January 2 and 3, 2014 at which time this would likely have avoided the load shedding that was required on those days. However, the system planning representatives advised this would not have assisted in maintaining service when the subsequent transmission outages took place in the following days.

The essential objective of the least cost generation planning is to find an expansion plan which would result in the lowest cost to electricity consumers for a given level of reliability. The consumer costs includes not only those that the utilities recover in their tariffs but also the cost of physical damages to equipment and facilities caused by interruptions as well as other indirect social costs and business costs including loss of production and employee productivity.