

| CONCRETE THICKNESS | |
|---------------------------------|-------|
| MINIMUM | 100mm |
| RESIDENTIAL DRIVEWAY | 150mm |
| COMMERCIAL/ INDUSTRIAL DRIVEWAY | 200mm |

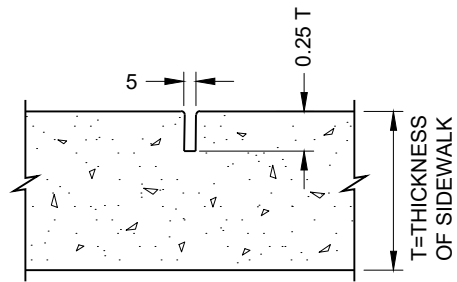

CONTRACTION JOINT

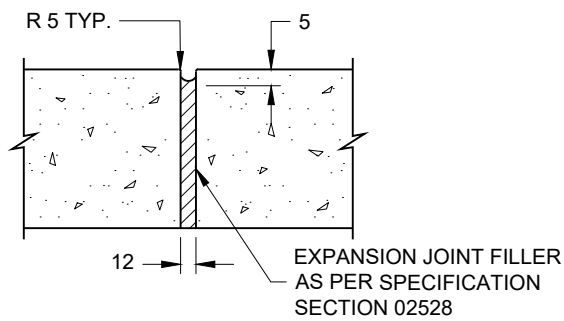

EXPANSION JOINT

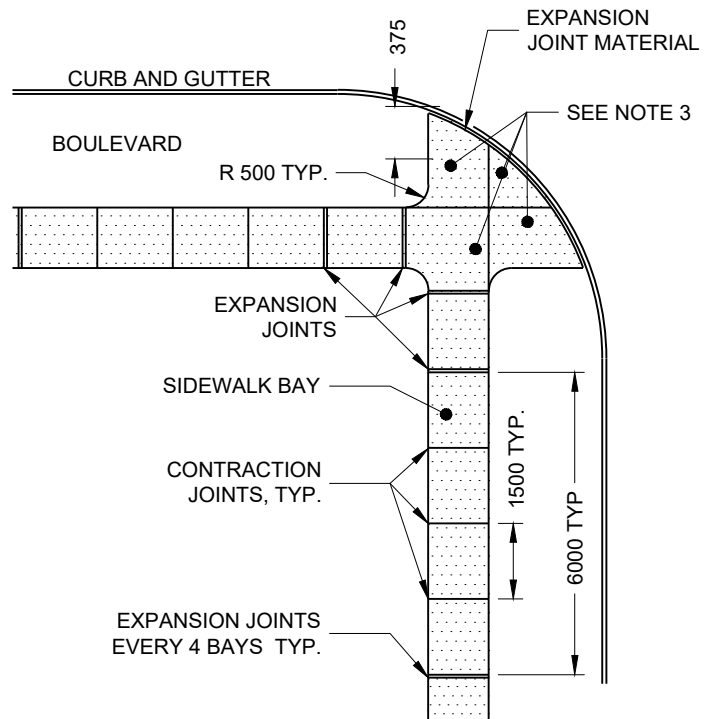

JOINT LAYOUT

NOTES:

- 32 MPa CONCRETE TO MEET CSA A23.1/A23.2, CLASS C-2 EXPOSURE. AS PER SPECIFICATION SECTION 02528.
- SIDEWALK WIDTH SHALL BE INCREASED TO 2400mm AT SCHOOLS, BUS STOPS, AND OTHER HIGH PEDESTRIAN AREAS. SIDEWALK LENGTH IS PROJECT SPECIFIC AND SHALL BE DETERMINED BY ENGINEER.
- THIS STANDARD DRAWING TO BE READ IN CONJUNCTION WITH STANDARD DRAWING 04150.
- ALL DIMENSIONS ARE IN MILLIMETERS UNLESS OTHERWISE SHOWN.
- WHERE CONTRACTION JOINTS ARE NEEDED, THE METHOD USED MUST GUARANTEE THAT AT LEAST 1/4 OF THE SIDEWALK THICKNESS OF CONCRETE IS INDENTED TO CONTROL DRYING SHRINKAGE CRACKING. SUITABLE METHODS ARE THE USE OF PREFORMED JOINT MATERIALS OR SAW CUTTING ONE QUARTER THE SLAB THICKNESS WITHIN 6 TO 18 HOURS AFTER THE CONCRETE HAS HARDENED BEFORE DRYING SHRINKAGE CRACKS APPEAR. FOR SLIPFORM CONSTRUCTION, THE JOINTS MAY BE FORMED USING A GUILLOTINE OR WIRE TO CUT THE PLASTIC CONCRETE, OR BY SAW CUTTING THE HARDENED CONCRETE.
- CONTRACTION JOINTS SHALL BE LOCATED AT 24 TO 30 T MAXIMUM. WHERE SIDEWALK WIDTH IS 2.5 m OR GREATER, A CONTRACTION JOINT SHOULD ALSO BE FORMED ALONG THE CENTERLINE OF THE WALK. CONTRACTION JOINT SPACING FOR SIDEWALK SHALL BE APPROXIMATELY THE SAME AS THE WIDTH AND NOT MORE THAN 1.5 TIMES THE WIDTH.
- ISOLATION JOINTS SHOULD BE LOCATED ADJACENT TO EXISTING STRUCTURES, (POLES, WALLS, HYDRANTS, BUILDINGS, ETC.) ISOLATION JOINTS SHOULD ALSO BE LOCATED BEFORE AND AFTER CURVE SECTIONS AND AT INTERSECTIONS.
- ISOLATION JOINT FILLER SHOULD BE 12 mm THICK.
- CONTRACTION JOINTS SHOULD BE LOCATED WHERE THE PLACING OF CONCRETE MUST BE STOPPED FOR A PERIOD IN EXCESS OF 30 MINUTES.

MUNICIPAL MASTER SPECIFICATIONS

CONCRETE SIDEWALK

DRAWING NUMBER 04100

DATE: APRIL 2023
SCALE: N.T.S.