

DETAIL COVER BOXOUT

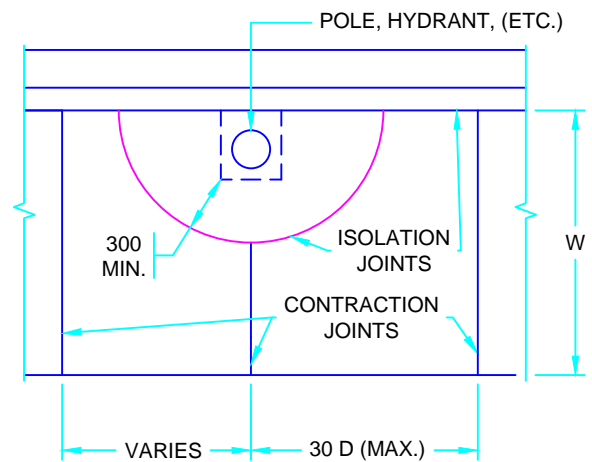

DETAIL POLE BOXOUT

NOTES:

1. WHERE CONTRACTION JOINTS ARE NEEDED, THE METHOD USED MUST GUARANTEE THAT AT LEAST 1/4 OF THE DEPTH OF CONCRETE IS INDENTED TO CONTROL DRYING SHRINKAGE CRACKING. SUITABLE METHODS ARE THE USE OF PREFORMED JOINT MATERIALS OR SAW CUTTING ONE QUARTER THE SLAB THICKNESS WITHIN 6 TO 18 HOURS AFTER THE CONCRETE HAS HARDENED BEFORE DRYING SHRINKAGE CRACKS APPEAR. FOR SLIPFORM CONSTRUCTION, THE JOINTS MAY BE FORMED USING A GUILLOTINE OR WIRE TO CUT THE PLASTIC CONCRETE, OR BY SAW CUTTING THE HARDENED CONCRETE.
2. CONTRACTION JOINTS SHALL BE LOCATED AT 24 TO 30 D MAXIMUM. WHERE SIDEWALK WIDTH IS 2.5 m OR GREATER, A CONTRACTION JOINT SHOULD ALSO BE FORMED ALONG THE CENTERLINE OF THE WALK. CONTRACTION JOINT SPACING FOR SIDEWALK SHALL BE APPROXIMATELY THE SAME AS THE WIDTH AND NOT MORE THAN 1.5 TIMES THE WIDTH.
3. CONTRACTION JOINTS IN CURB AND GUTTER SECTIONS SHOULD EXTEND COMPLETELY THROUGH THE CURB HEIGHT AND D/4 INTO THE GUTTER SECTION. WHEN SIDEWALK IS ADJACENT TO CURB, MAKE JOINTS OF CURB AND SIDEWALK ALIGN.
4. IF THE CURB IS INTEGRAL WITH CONCRETE PAVEMENT, CONTRACTION JOINT SPACING IN THE CURB SHOULD MATCH THAT IN THE PAVEMENT.
5. SPACING OF CONTRACTION JOINTS SHOULD VARY TO COINCIDE WITH THE CENTER OF MANHOLES OR OTHER BOX-OUTS.
6. ISOLATION JOINTS SHOULD BE LOCATED ADJACENT TO EXISTING STRUCTURES, (POLES, WALLS, HYDRANTS, BUILDINGS, ETC.) ISOLATION JOINTS SHOULD ALSO BE LOCATED BEFORE AND AFTER CURVE SECTIONS AND AT INTERSECTIONS.
7. ISOLATION JOINT FILLER SHOULD BE 12 mm THICK.
8. CONTRACTION JOINTS SHOULD BE LOCATED WHERE THE PLACING OF CONCRETE MUST BE STOPPED FOR A PERIOD IN EXCESS OF 30 MINUTES.
9. ALL SIDEWALKS SHOULD BE SLOPED AT LEAST 2% TO DRAIN TOWARDS THE STREET.
10. MAXIMUM SLOPE FOR WHEELCHAIR RAMPS SHOULD BE 8%.
11. SIDEWALKS SHOULD BE THICKENED TO 150 mm MINIMUM AT DRIVEWAY ENTRANCES.
12. D = SIDEWALK DEPTH
13. ALL DIMENSIONS ARE IN MILLIMETERS UNLESS OTHERWISE SHOWN.

**MASTER
SPECIFICATIONS**

CONCRETE JOINT NOTES

DRAWING NUMBER

04110

DATE:

MARCH 2016

SCALE:

N.T.S.