

HEIGHT OF GUARD SHALL NOT EXCEED 900mm IN HEIGHT WHERE THE WALKING SURFACE SERVED BY THE GUARD IS NOT MORE THAN 1800mm ABOVE THE FINISHED GROUND LEVEL.

HEIGHT OF GUARD SHALL BE NO LESS THAN 1070mm IN HEIGHT WHERE THE WALKING SURFACE SERVED BY THE GUARD IS NOT MORE THAN 1800mm ABOVE THE FINISHED GROUND LEVEL.

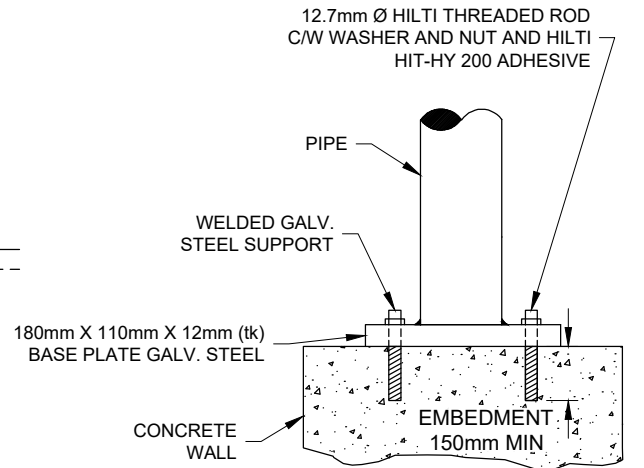

CONNECTIONS DETAIL FOR WALL CONDITIONS - BASE PLATE OPTION

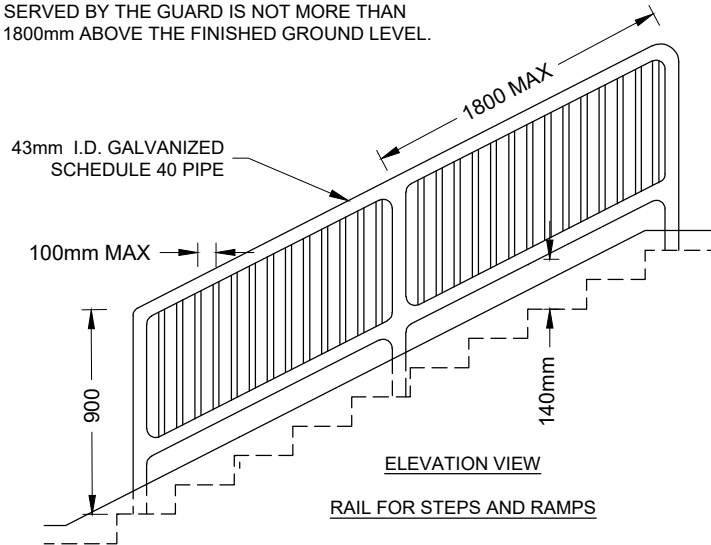
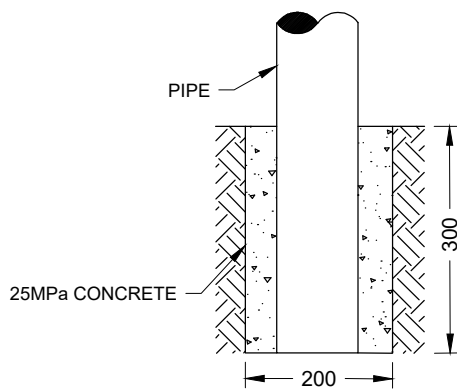

FOOTING DETAIL FOR O.M. CONDITIONS

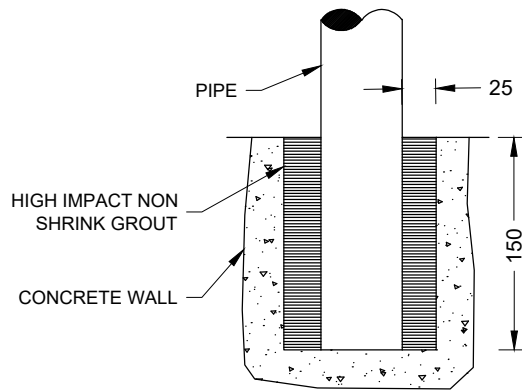

CONNECTIONS DETAIL FOR WALL CONDITIONS - CORE & GROUT OPTION

NOTES:

1. ALL WELDING TO BE IN ACCORDANCE WITH THE LATEST EDITION OF CSA W59.