

1500 TO 1200MM DIAMETER MAINTENANCE HOLE

NOTES:

1. THIS STANDARD DRAWING SHALL BE READ IN CONJUNCTION WITH STANDARD DRAWING 04200.
2. CENTER REINFORCING IN TRANSITION CONE ± 25 mm ALL OTHER REINFORCING STEEL SHALL HAVE 25mm MINIMUM COVER.
3. STEPS SHALL BE ACCORDING TO STANDARD DRAWING 04280.
4. ALL DIMENSIONS ARE NOMINAL.
5. ALL DIMENSIONS ARE IN MILLIMETERS UNLESS OTHERWISE SHOWN.

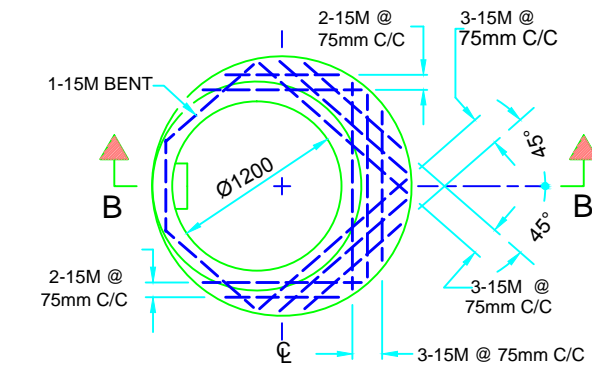

PLAN OF TRANSITION SLAB WITH REINFORCING STEEL BARS

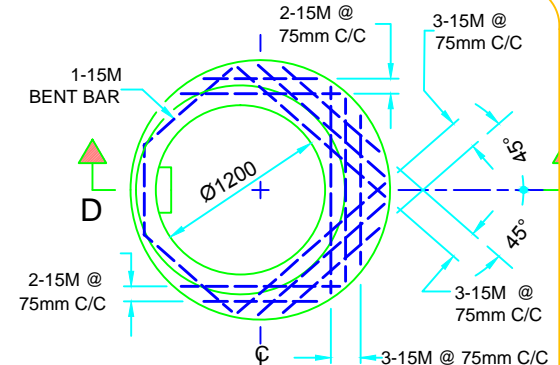

PLAN OF TAPERED TRANSITION SLAB WITH REINFORCING STEEL BARS

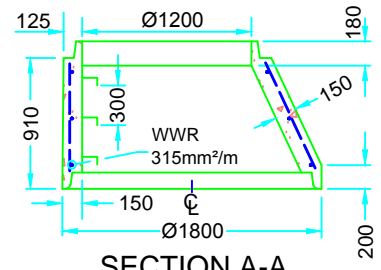

SECTION A-A

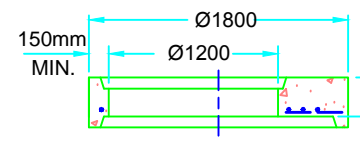

SECTION B-B

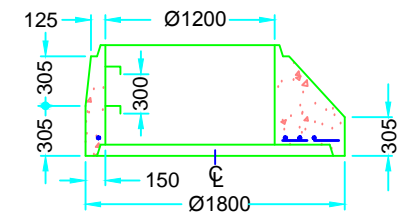

SECTION D-D

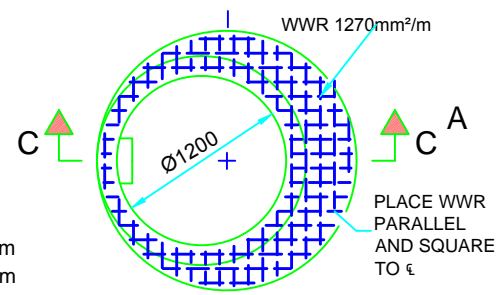

PLAN OF TRANSITION SLAB WITH WWR

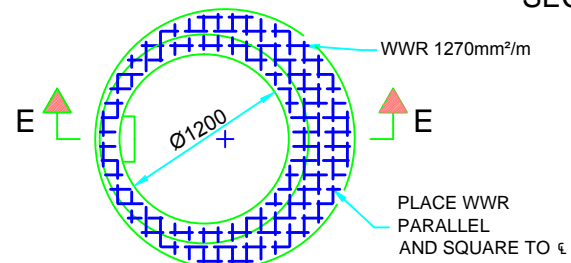

PLAN OF TAPERED TRANSITION SLAB WITH WWR

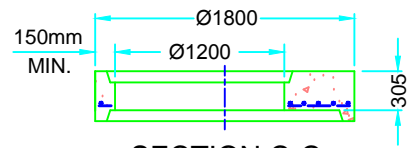

SECTION C-C

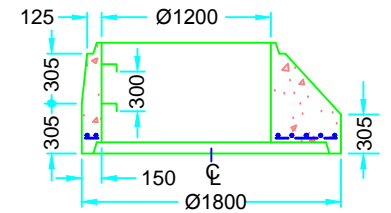

SECTION E-E

MASTER SPECIFICATIONS

PRECAST CONCRETE MAN HOLE COMPONENTS
1500mm DIAMETER TRANSITION CONE AND SLABS

DRAWING NUMBER 04230

DATE: MARCH 2016
SCALE: N.T.S.