

NOMINAL DIAMETER (mm)	EFFECTIVE AREA (m ²)	VERTICAL BENDS DOWN																				NOMINAL DIAMETER (mm)	EFFECTIVE AREA (m ²)	REDUCERS				
		90°					45°					22 1/2°					11 1/4°							R	RE-BAR	A	B	CONC
		R	RE-BAR	A	B	CONC	R	RE-BAR	A	B	CONC	R	RE-BAR	A	B	CONC	R	RE-BAR	A	B	CONC							
100	0.012	1.74	15M	1150	525	0.75	0.94	15M	900	450	0.38	0.37	15M	750	450	0.19	0.24	15M	750	450	0.19	100 X 150	0.012	1.32	15M	900	450	0.57
150	0.025	3.61	20M	1525	750	1.72	1.95	20M	1225	600	0.98	1.00	15M	900	450	0.38	0.50	15M	900	450	0.38	150 X 200	0.017	1.84	15M	900	600	0.57
200	0.042	6.21	25M	1825	900	2.87	3.36	20M	1450	675	1.53	1.71	15M	1075	525	0.76	0.86	15M	900	450	0.38	150 X 250	0.038	4.03	15M	1200	750	1.15
250	0.063	9.21	25M	2050	975	4.20	5.03	25M	1675	750	2.29	2.61	20M	1375	675	1.15	1.29	15M	1075	525	0.57	150 X 300	0.064	6.80	20M	1200	900	1.34
300	0.088	13.24	25M	2275	1150	5.92	7.12	25M	1900	900	3.25	3.65	20M	1525	750	1.72	1.84	20M	1150	525	0.76	200 X 300	0.047	4.97	15M	1200	750	1.15

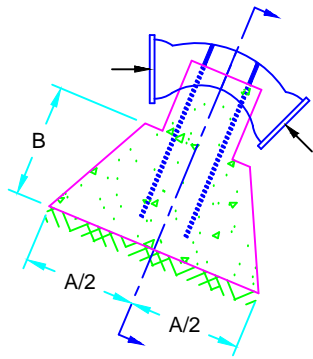

ELEVATION

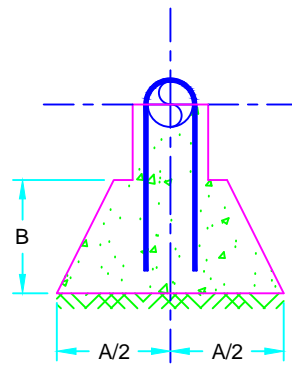

SECTION

VERTICAL BEND DOWN

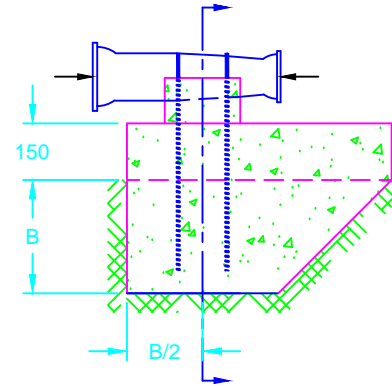

ELEVATION

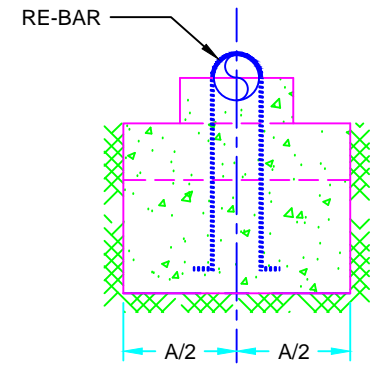

SECTION

REDUCER

NOTES:

1. CONCRETE SHALL BE 25 MPa 28 DAY STRENGTH.
2. RE-BARS, REINFORCING STEEL STRUCTURAL GRADE 125 MPa MINIMUM WORKING STRESS WHEN EXPOSED TO SOIL BARS SHALL BE COATED WITH ASPHALT PAINT TO PREVENT CORROSION.
3. BLOCKS SHALL BE POURED DIRECTLY AGAINST UNDISTURBED SOIL AS INDICATED.
4. DESIGN DATA - STATIC PRESSURE 1000KPa.
- MINIMUM BEARING CAPACITY OF SOIL 120 KPa.
5. ALL DIMENSIONS ARE IN MILLIMETERS UNLESS OTHERWISE SHOWN.

ABBREVIATIONS:

- | | |
|-------|---|
| R | REACTION IN 1000 Kg. |
| CONC. | VOLUME OF CONCRETE IN m ³ . |
| A & B | DIMENSION OF CONCRETE IN mm UNLESS OTHERWISE NOTED. |

MASTER
SPECIFICATIONS

WATERMAIN THRUST BLOCKS B

DRAWING NUMBER 04600

DATE:
MARCH 2022

SCALE:
N.T.S.